



2-CYCLE GASOLINE POWERED POST DRIVER ASSEMBLY & OPERATING INSTRUCTIONS

READ ALL INSTRUCTIONS AND WARNINGS BEFORE USING THIS PRODUCT.

This manual provides important information on proper operation & maintenance. Every effort has been made to ensure the accuracy of this manual. These instructions are not meant to cover every possible condition and situation that may occur. **We reserve the right to change this product at any time without prior notice.**

IF THERE IS ANY QUESTION ABOUT A CONDITION BEING SAFE OR UNSAFE, DO NOT OPERATE THIS PRODUCT!

If you experience a problem, have questions or need parts for this product, call Customer Service at **218-943-4290, Monday-Friday, 8 AM - 4 PM Central Time**. A copy of the sales receipt is required.

FOR CONSUMER USE ONLY – NOT FOR PROFESSIONAL USE.

KEEP THIS MANUAL, SALES RECEIPT & APPLICABLE WARRANTY FOR FUTURE REFERENCE.

⚠ WARNING

CALIFORNIA PROPOSITION 65 : This product, or the exhaust from this driver, may contain chemicals, including lead, known to the State of California to cause cancer and birth defects or other reproductive harm. Wash hands after handling.

INDEX

I	Part Information / Specifications	3
II	Safety Instructions	4
III	Use and Function	4
IV	Assembly	5
V	Starting.....	7
VI	Operation.....	7
VII	Turning off the Motor	8
VIII	Maintenance	8
IX	Troubleshooting.....	10
X	Maintenance Cycle	11
XI	Parts List	12

PACKING LIST

1. Post Driver.....	1 Piece
2. Piling Socket Guide SleeveΦ49	1 Piece
3. Piling Socket Guide SleeveΦ69	1 Piece
4. Inner Post Head Φ67	1 Piece
5. Oil/Fuel Mix Container	1 Piece
6. Grease for Cylinder (60g)	1 Piece
7. Piling Socket Removal Tool.....	1 Piece
8. Instructions	1 Piece
9. Tool hardware package :	
1 piece 4mm inner hexagon spanner	
1 piece 5mm inner hexagon spanner	
1 piece 6mm inner hexagon spanner	
1 piece T-shaped inner hexagon spanner	
1 piece straight screwdriver	
1 piece 8-10mm open spanner	

1 Name of Main Parts

No.	Name of Part	No.	Name of Part	No.	Name of Part
1	Combined switch	2	Stop Button	3	Starter
4	Throttle control button	5	Throttle Button	6	Hammer Case
7	Shock guide sleeve	8	Piling Socket	9	Support Plate
10	Handle sleeve	11	Damping Spring	12	Locating Sleeve
13	Handle	14	Spark Plug	15	Ventilation Door Switch
16	Air Filter	17	Oil Cover	18	Oil Pot
19	Fuel Bubble	20	Steel Cover	21	Throttle Pull

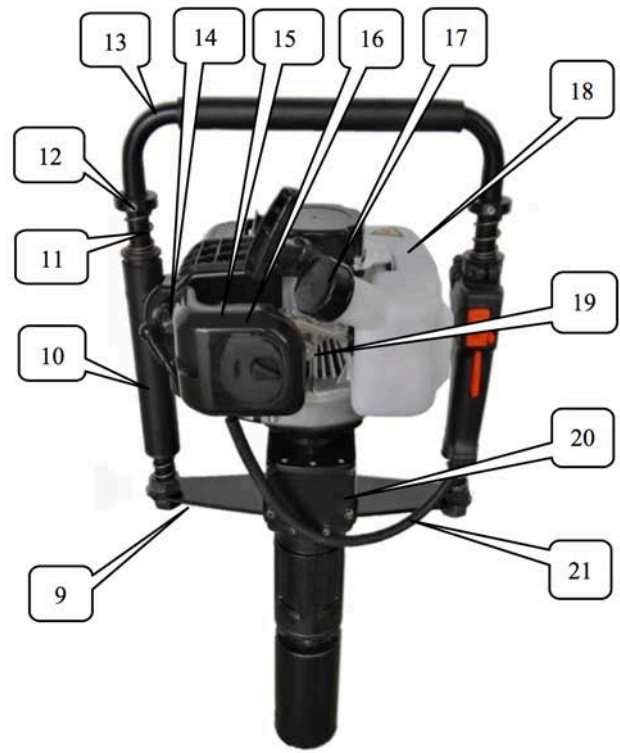
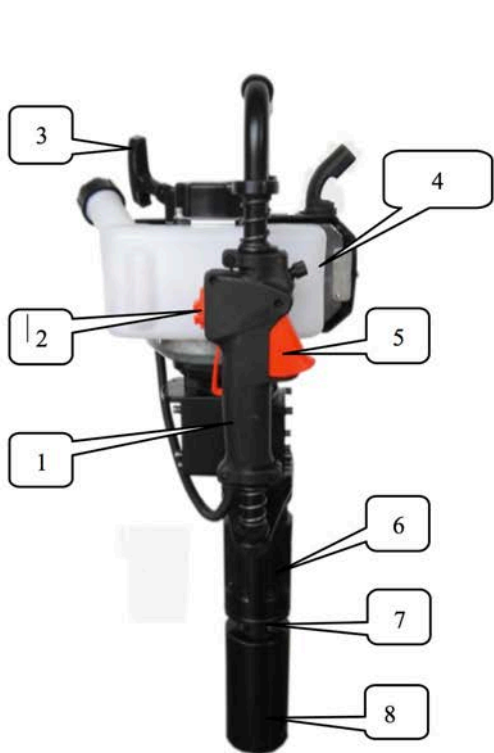

SPECIFICATIONS

Engine type	Single cylinder, air cooling, 2 stroke, cylinder diameter × stroke: 36×32mm		
Fuel	Mixed oil (Gasoline: two-stroke engine oil= 30:1)		
Fuel tank capacity	1.0675 quart (34.16 ounces)		
Weight	28.66 lbs		
Displacement	32.7CC		
Max power/speed	0.9KW/7500r/min	Spark plug type	L6T
Max torque/speed	1.45N.m/5000r/min		
Fuel consumption	≤0.50L/h		
Impact frequency	1700~2230 RPM		
Impact energy	20~45J		
Carburetor type	1E36F-2E.1A"		

IMPORTANT SAFETY INSTRUCTIONS – SAVE THESE INSTRUCTIONS

1. The operator must wear slip-resistant safety shoes and suitable clothing.
The operator must wear safety glasses, helmet, and ear protection.
2. While operating the machine, please keep balance of body; the user should stand behind the support handle and operate the machine. While operating the machine, do not smoke, eat or chat.
3. After starting the machine, do not carry out one-handed operation.
4. While lifting the machine, do not pull Throttle Switch.
5. Children, pets, and by-standers should stay away from operating area to avoid injury.
6. Select the medium speed to operate pile driver.
7. Keep the handle dry and clean without greasy oil or fuel mixture.
8. If operation is stopped midway: turn off the engine.
9. Always check connections and hardware before use. If loose, you must tighten before use.
10. Gasoline is highly flammable. Replenish fuel in a well-ventilated area. During fuel filling, gasoline engine must be turned off. Do not use pure gasoline, use the appropriate 2-stroke engine oil. Ratio: 30:1
11. Do not over fill. The oil shall not exceed the neck of oil filler of Fuel Tank. If fuel spills, wait until the fuel volatilizes completely and then start the machine.
12. Gasoline is highly flammable. Refuel in a well-ventilated area. When refueling, please turn off the gasoline engine.
13. After refueling, tighten the oil lid. During operation, check whether Fuel Tank is damaged and leaking. If damage is found, turn off the machine immediately for replacement.
14. While post driver is used in closed areas of work environment such as tunnels, trenches and deep groove, it's necessary to guarantee normal air circulation to avoid waste gas poisoning and suffocation.
15. Before transport, empty fuel inside Fuel Tank to avoid leakage.
16. Non-professional maintenance staff are prohibited from dismounting post driver to avoid structural damage of parts, shortened service life of post driver or accidents.
17. Before transport, empty fuel inside the oil tank to avoid leakage.

ASSEMBLY



Fig. 1) Identify Post Driver, Piling Socket Sleeves (2 pieces), Inner Post Head and Socket Pin.!



Fig. 2) Attach Piling Socket Sleeve by screwing it onto Post Driver.



Fig. 3) Insert Socket Pin, then rotate Piling Socket Sleeve $\Phi 69$ to make sure it is tight & secure.!



Fig. 4) Insert Inner Post Head $\Phi 67$. Use a wood handle or metal bar to force inside Sleeve.

* NOTE: Piling Socket Sleeve $\Phi 49$ does NOT need Inner Post Head!



Fig. 5) To remove, insert Socket Pin then rotate Piling Socket Sleeve.



Fig. 6) Pull hard and wiggle Piling Socket Sleeve until it is removed.

USE AND FUNCTION

Use: Use for outside piling operation for farm fences, orchard fences or barriers.

Function:

- The operator can achieve 360° all-around operation.
- Can drive posts up to 2.67 inches (68mm) in diameter.
- Two-way Damping Spring helps reduce vibration.

MIXING GAS/OIL FUEL

Use only quality gasoline and two-stroke special engine oil.

Recommended mixing ratio:

Condition	Gasoline : 2-Cycle Engine Oil
Operation within 20 hours	30:1
Operation of over 20 hours	30:1

1. Mix fuel in a container outside in a well ventilated area.
2. Fill certified fuel container with recommended fuel.
3. Add recommended amount of 2 cycle oil.
4. Screw container cap on straight and tight.
5. Shake the container to mix fuel and oil.
6. Unscrew gas cap slowly to vent, add the remainder of fuel requirements
7. Wipe away any spilled fuel or oil and allow to evaporate before moving or transporting.

STARTING INSTRUCTIONS

Before starting, press the primer button repeatedly until Carburetor is filled with fuel. (If the engine is cool, close the Choke. Then open Choke after starting.)



Hold the machine upright. Hold the upper part of handle tightly with one hand, while the other hand quickly pulls the recoil start. Do not let the recoil handle go back freely. Instead, hold it tightly to avoid injury.

When the engine has started, open the choke completely. After idling for approximately 5 minutes, you can start working.

OPERATION

After engine is started, allow 5 minutes idle operation to warm up the machine.
When the engine is warmed up, press throttle handle to the appropriate speed.

Note: The unit will provide low or medium-speed for work in the first 6 hours of operation and the maximum throttle should not be used.

High-speed operation of the post driver during non-piling is prohibited.

TURNING OFF MOTOR

Release throttle handle and allow to idle for 3-5 minutes.
Pull Stop Switch.



MAINTENANCE

Fuel filter

If the fuel filter is blocked, the post driver will have reduced speed and weaker impact energy.

- ① Open the Fuel Tank lid. Remove fuel filter from Fuel Tank with a metal hook or pliers.
When cleaning the fuel filter, clean the Fuel Tank at same time. See Fig.14, 15 and 16.



Air Filter

Check air filter regularly. Soot deposit blocking air filter will reduce power of gasoline engine and service life. If the filter has too much soot deposit, clean it with warm water and detergent, and then wipe dry it with dry cloth, and then install the air filter. Replace Filter if damaged. If working in a dusty environment, maintain more often.

Silencer

Regularly remove dirt on inlet and outlet of silencer, or clean dirt in it with detergent.

Cylinder Cooling Fin

Regularly remove dust to ensure the cylinder cooling conditions are well. The gasoline pile driver is air-cooling type. If dust gathers on the cylinder cooling fin, the cooling effect will be influenced directly.

Carburetor

When the machine is not used for more than one week, be sure to completely remove the fuel. Pull out the oil inlet pipe, press Primer Button of carburetor repeatedly for oil discharge, and return the oil inlet pipe back to its position when fuel in Fuel Bubble and oil return pipe is empty.

Spark Plug

Remove sediment with a wire brush.
Spark Plug gap is 0.5-0.7 mm.

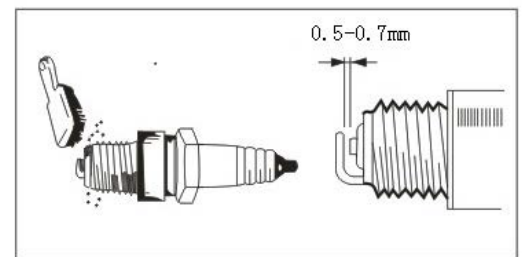
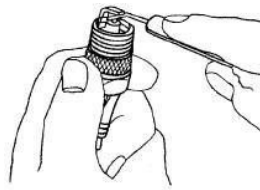

Add lubricating oil to impact cylinder

After the machine has been working for 50 hours, the included special grease should be added to the impact cylinder. Open the cover of gear boxes and lubricate the gear and the connecting rod with lubricating oil as shown in Fig. 17, 18, 19.



Fig.17



Fig.18

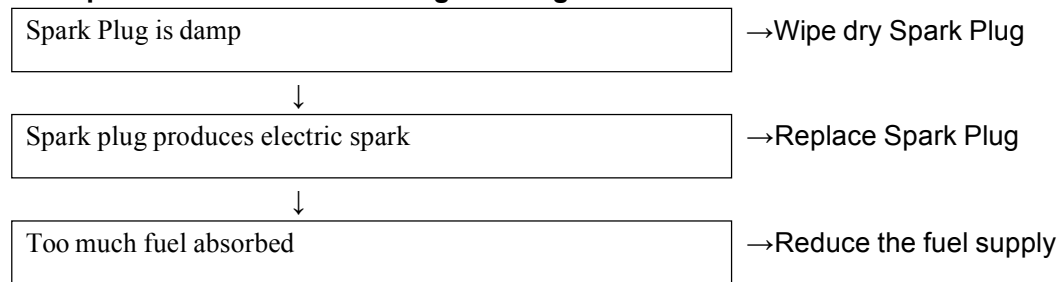

Fig.19

TROUBLESHOOTING

Problem analysis and solving

Example 1: Difficulties in starting cool engine.



Example 2: Restarting after sudden stop

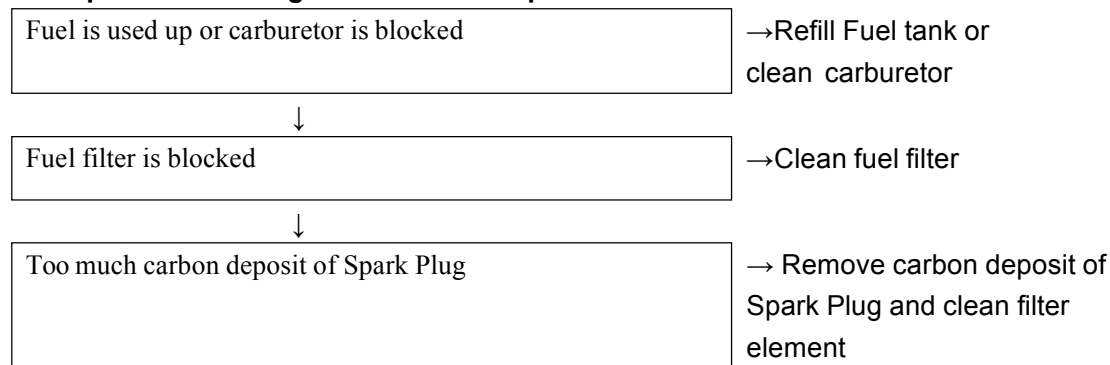

Example 3: Slow, weak power

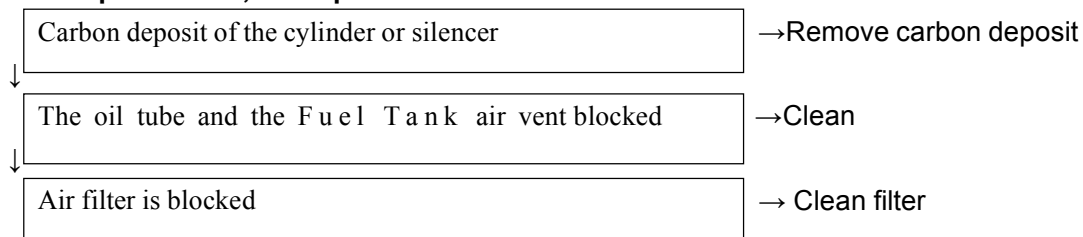

Example 4: Loud Sound

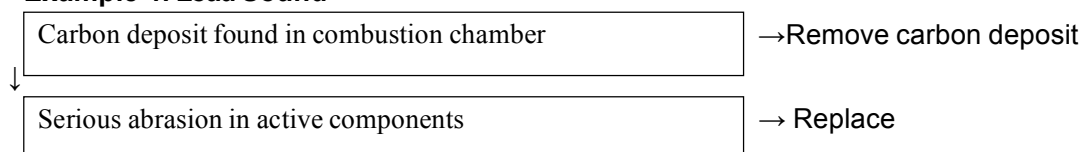

Example 5: The machine is working normally but the work efficiency is very low

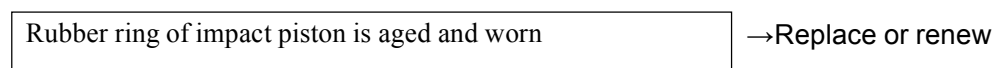

MAINTENANCE

The following data is provided for common use of the product. Under worse working conditions such as thick dust or longer work hours, the maintenance cycle should be shortened.		Before work	After work or every day	After Filling oil	Every Week	Every Month	Temporary Failure	If necessary
The whole machine	Outlook check (state, tightness of screws)	√		√				
	Clean		√					
Control handle/stop button	Function check	√		√				
Air Filter	Clean				√			√
	Replace						√	
Fuel Filter	Check					√		
	Replace						√	
Petrol Tank/Petrol Tank cover	Clean		√	√				
	Check	√		√				
	Tighten							√
Gear Box/Cylinder	Clean					√		
	Add oil							√
Silencer	Check					√		
	Remove carbon deposit							√
Cylinder Cooling Fin	Check					√		
	Clean							√
Spark Plug	Check/Adjust the distance between electrodes					√		
	Replace							√
Screw and Nut	Check	√		√				
	Tighten							√

PARTS LIST

Part No.	Name	Qty	Part No.	Name	Qty
1	Recoil Start Assembly - Screw	1	41	Piston Ring	1
2	Recoil Start Assembly - Start Wheel	1	42	Cylinder Gasket	1
3	Recoil Start Assembly - Rope Sheave	1	43	Cylinder Body	1
4	Recoil Start Assembly - Rope	1	44	Screw Assembly M5x18	4
5	Recoil Start Assembly - Starter Flat Spring	1	45	Cylinder Cover Assembly	1
6	Recoil Start Assembly - Shell	1	46	Screw Assembly M5x16	1
7	Screw Assembly M5X25	6	47	Spark Plug	1
8	Recoil Start Assembly - Starter Handle	1	48	Spark Plug Jump Ring	1
9	Recoil Start Assembly - Cover	1	49	Spark Plug Cover	1
10	Recoil Start Assembly - Compressed Spring	1	50	High Voltage Cap	1
11	Recoil Start Assembly - Start Button Pole	1	51	Rubber Plug	1
12	Starter	1	52	Upper Gland	1
13	Starter Pad	1	53	Silencer Pad	1
14	Starter Hub	1	54	Silencer	1
15	Small Oil Seal	1	55	Screw Assembly M5x12	2
16	Rear Half Crankcase	1	56	Washer 5	2
17	Crankcase Seal Pad	1	57	Screw Assembly M6x60-12.9	2
18	Bearing 6202/P6	2	58	Intake Gasket	1
19	Crank Connected Rod Group	1	59	Intake	1
20	Woodruff-Key 3X3X13	1	60	Carburetor Mat	1
21	Pin B4X10	4	61	Carburetor	1
22	Front Half Crankcase	1	62	Choke Valve Handle	1
23	Screw Assembly M5X30	4	63	Retaining Plug	1
24	Magneto Rotor	1	64	Nut M4	1
25	Washer 8	1	65	Air Filter Inner Cover	1
26	Washer 8	1	66	Screw Assembly M5x55	2
27	Nut M8	1	67	Choke Valve	1
28	Magneto Stator	1	68	Tapping Screw ST4.2X12	1
29	Stall Quad	1	69	Filter Element	1
30	Screw Assembly M5x20	2	70	Air Filter Outer Cover	1
31	Washer B	2	71	Big Head Screw	1
32	Tension Spring	1	72	Fuel Tank Rack	1
33	Tensioning Block	2	73	Rubber Sleeve	1
34	Wave Washer	2	74	Fuel Filter	1
35	Screw Shaft	1	75	Rubber Tube	1
36	Magneto Casing	1	76	Oil Tube Rubber Plug	1
37	Small Needle Roller Bearing	1	77	Soft PVCLS-3X1X75	1
38	Piston Pin Baffle Ring	2	78	Screw Assembly M5x16	2
39	Piston	1	79	Fuel Tank	1
40	Piston Pin	1	80	Gas Cap Chain	1
Part No.	Name	Qty	Part No.	Name	Qty
81	End Cover		87	Rubber Pad	2
82	Oil Pot Inner Cover	1	88	Heat Shield	1
83	Suction Nozzle	1	89	Screw Assembly M4X8	1
84	Gasket	1	90	Washer 5	2
85	Oil Cover	1	91	Gas Guide Tube	1
86	Tank Cover Assembly	1			

PARTS DIAGRAM

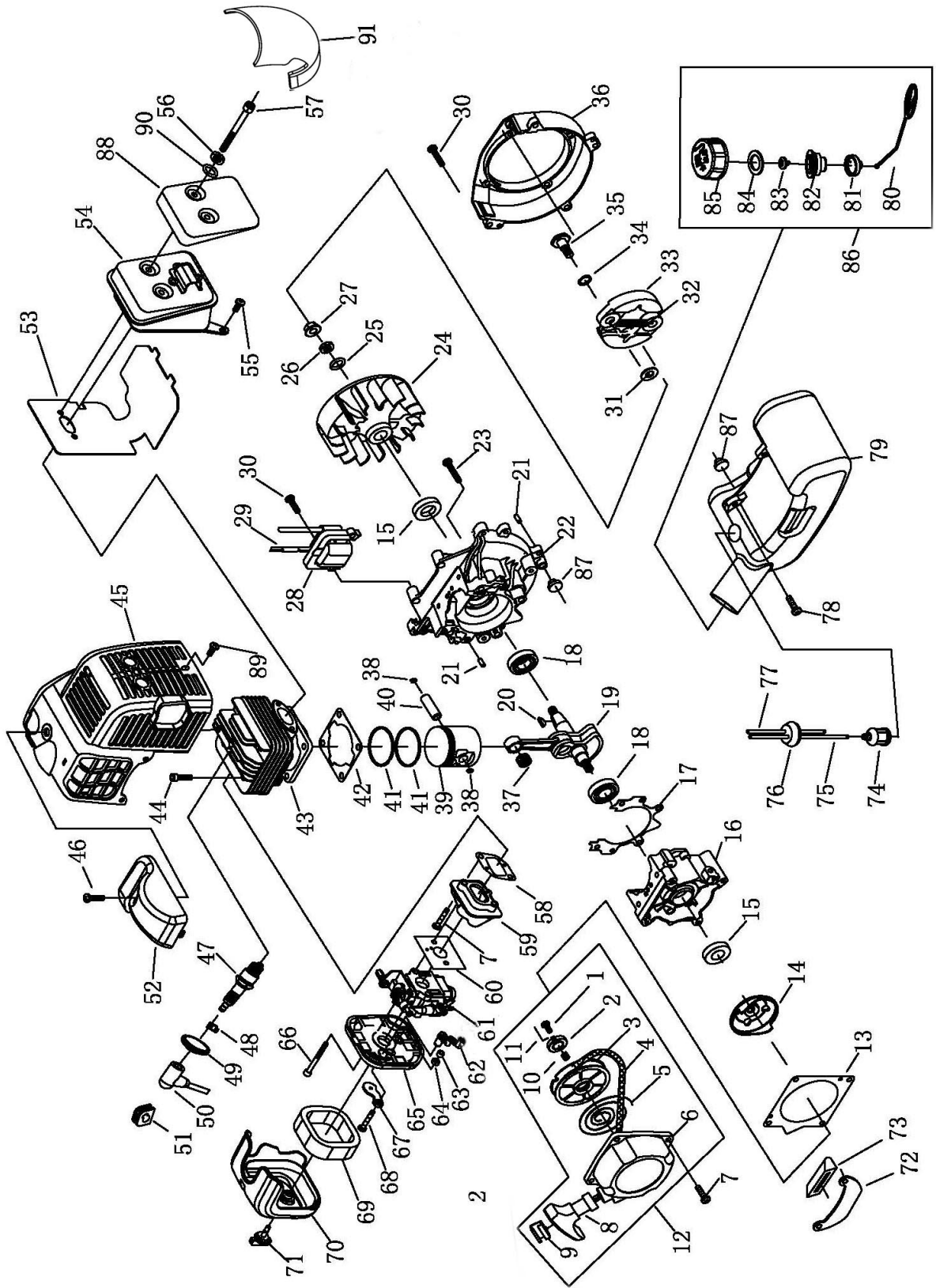

PARTS LIST

Parts No.	Name	Qty	Parts No.	Name	Qty
1	Gasoline Engine	1	41	Right Paper Pad	1
2	Clutch Plate	1	42	Right Steel Cover	1
3	Circlip for Hole A Type 40	2	43	Ram O-ring	1
4	Deep Groove Ball Bearing 6203-2RZ	4	44	Ram	1
5	Bevel Pinion	1	45	Impact Cylinder	1
6	Reduction Gearbox	1	46	Shock	1
7	Hexagon Socket Head Cap Screw M6×8	3	47	Shock O-ring	2
8	Flat Gasket Φ16XΦ22X0.5	1	48	Crash Pad	2
9	Bevel Gear Wheel	1	49	Wave Washer Φ39×46×0.5	6
10	Flat Gasket 10	1	50	Shock Guide Sleeve	1
11	Elastic Washer 10	1	51	Piling Socket 69	1
12	Hexagon Thin Nut M10	1			
13	Right Paper Pad	1			
14	Right Steel Cover	1			
15	Hexagon Socket Head Cap Screw M5×14	12			
16	Elastic Washer 6	5			
17	Hexagon Socket Head Cap Screw M6×20	4			
18	Impact Piston	1			
19	Impact Piston Pin	1			
20	Impact Piston O-ring	2			
21	Handle Soft Cover	1			
22	Handle	1			
23	Locating Sleeve	2			
24	Hexagon Socket Head Cap Screw M6×35	2			
25	Damping Spring	4			
26	Guide Sleeve	2			
27	Combined Switch	1			
28	Support Plate	1			
29	Hammer Case	1			
30	Elastic Washer 8	10			
31	Hexagon Socket Head Cap Screw m8×30	10			
32	Outer-Hexagonal Flange Self-Locking Nut M18×1.5	2			
33	Handle Connecting Thread Joint	2			
34	Handle Sleeve	1			
35	Handle Soft Sleeve	1			
36	Impact Crank	1			
37	Needle Bearing HK152316	1			
38	Impact Connecting Rod	1			
39	Retainer Ring	1			
40	Hexagon Socket Head Cap Screw m6×16	1			

PARTS DIAGRAM

