





## 1.0 WARRANTY AND SERVICE

JET® warrants every product it sells against manufacturers' defects. If one of our tools needs service or repair, please contact Technical Service by calling 1-855-336-4032, 8AM to 5PM CST, Monday through Friday.

### WARRANTY PERIOD

The general warranty lasts for the time period specified in the literature included with your product or on the official JET branded website, [jettools.com](http://jettools.com)



### WHO IS COVERED?

This warranty covers only the initial purchaser of the product from the date of delivery.

### WHAT IS COVERED?

This warranty covers any defects in workmanship or materials subject to the limitations stated below. This warranty does not cover failures due directly or indirectly to misuse, abuse, negligence or accidents, normal wear-and-tear, improper repair, alterations or lack of maintenance.

### HOW TO GET TECHNICAL SUPPORT

Please contact Technical Service by calling 1-855-336-4032. Please note that you will be asked to provide proof of initial purchase when calling. If a product requires further inspection, the Technical Service representative will explain and assist with any additional action needed. JET has Authorized Service Centers located throughout the United States. For the name of an Authorized Service Center in your area call 1-855-336-4032 or use the Service Center Locator on the JET website.

### **MORE INFORMATION**

JET® is constantly adding new products. For complete, up-to-date product information, check with your local distributor or visit the JET website, [jettools.com](http://jettools.com)

### **HOW STATE LAW APPLIES**

This warranty gives you specific legal rights, subject to applicable state law

### **LIMITATIONS ON THIS WARRANTY**

JET LIMITS ALL IMPLIED WARRANTIES TO THE PERIOD OF THE LIMITED WARRANTY FOR EACH PRODUCT. EXCEPT AS STATED HEREIN, ANY IMPLIED WARRANTIES OF MERCHANTABILITY AND FITNESS FOR A PARTICULAR PURPOSE ARE EXCLUDED. SOME STATES DO NOT ALLOW LIMITATIONS ON HOW LONG AN IMPLIED WARRANTY LASTS, SO THE ABOVE LIMITATION MAY NOT APPLY TO YOU.

JET SHALL IN NO EVENT BE LIABLE FOR DEATH, INJURIES TO PERSONS OR PROPERTY, OR FOR INCIDENTAL, CONTINGENT, SPECIAL, OR CONSEQUENTIAL DAMAGES ARISING FROM THE USE OF OUR PRODUCTS. SOME STATES DO NOT ALLOW THE EXCLUSION OR LIMITATION OF INCIDENTAL OR CONSEQUENTIAL DAMAGES, SO THE ABOVE LIMITATION OR EXCLUSION MAY NOT APPLY TO YOU.

JET sells through distributors only. The specifications listed in JET printed materials and on official JET website are given as general information and are not binding. JET reserves the right to effect at any time, without prior notice, those alterations to parts, fittings, and accessory equipment which they may deem necessary for any reason whatsoever. JET® branded products are not sold in Canada by JPW Industries, Inc.

NOTE: JET is a division of JPW Industries, Inc. References in this document to JET also apply to JPW Industries, Inc., or any of its successors in interest to the JET brand.



## 2.0 TABLE OF CONTENTS

1.0 WARRANTY AND SERVICE.....	2
2.0 TABLE OF CONTENTS.....	4
3.0 SAFETY PRECAUTIONS .....	5
4.0 INTRODUCTION .....	7
5.0 SPECIFICATION AND ACCESSORIES.....	7
5.1 GENERAL LAYOUT OF LATHE .....	7
5.2 DIMENSIONS .....	8
5.3 FOUNDATION PLAN.....	8
5.4 SPECIFICATIONS AND ACCESSORIES.....	9
6.0 INSTALLATION .....	10
6.1 LIFTING.....	10
6.2 CLEANING.....	10
6.3 INSTALLING .....	10
6.4 LUBRICATION CHECKS .....	11
6.5 CHUCKS AND CHUCK MOUNTING .....	11
7.0 OPERATION .....	12
7.1 LATHE CONTROL.....	12
7.2 ELECTRICAL CONTROLS.....	12
7.3 SPINDLE SPEED SELECTORS .....	13
7.4 THREADS AND FEEDS.....	13
7.5 THREADING DIAL INDICATOR.....	14
7.6 APRON CONTROLS (LEVER TYPE) .....	14
7.7 CROSS SLIDE AND TOP SLIDE .....	14
7.8 TAIL STOCK.....	15
8.0 SERVICING AND MAINTENANCE .....	15
8.1 LATHE ALIGNMENT (PART 1) .....	15
8.2 LATHE ALIGNMENT (PART 2).....	15
8.3 END GEAR TRAIN .....	16
8.4 DRIVING BELTS.....	16
8.5 SLIDE WAYS ATTENTION .....	16
8.6 CROSS-SLIDE NUT.....	16
8.7 LUBRICATION (PART 1).....	17
8.8 LUBRICATION (PART 2).....	17
8.9 LUBRICATION DIAGRAM .....	18
9.0 RECOMMENDED CUTTING SPEED OF LATHE .....	19
10.0 REPLACEMENT PARTS.....	20
11.0 WIRING DIAGRAMS .....	66



### 3.0 SAFETY PRECAUTIONS

1. Read and understand the entire owner's manual before attempting assembly or operation.
2. Read and understand the warnings posted on the machine and in this manual. Failure to comply with all of these warnings may cause serious injury.
3. Replace the warning labels if they become obscured or removed.
4. This lathe is designed and intended for use by properly trained and experienced personnel only. If you are not familiar with the proper and safe operation of a lathe, do not use until proper training and knowledge have been obtained.
5. Do not use this lathe for other than its intended use. If used for other purposes, JET®, disclaims any real or implied warranty and holds itself harmless from any injury that may result from that use.
6. Always wear approved safety glasses/face shields while using this lathe. Everyday eyeglasses only have impact resistant lenses; they are not safety glasses.
7. Before operating this lathe, remove tie, rings, watches and other jewelry, and roll sleeves up past the elbows. Remove all loose clothing and confine long hair. Non-slip footwear or anti-skid floor strips are recommended. Do not wear gloves.
8. Wear ear protectors (plugs or muffs) during extended periods of operation.
9. Do not operate this machine while tired or under the influence of drugs, alcohol or any medication.
10. Make certain the switch is in the OFF position before connecting the machine to the power supply.
11. Make certain the machine is properly grounded.
12. Make all machine adjustments or maintenance with the machine unplugged from the power source.
13. Remove adjusting keys and wrenches. Form a habit of checking to see that keys and adjusting wrenches are removed from the machine before turning it on.
14. Keep safety guards in place at all times when the machine is in use. If removed for maintenance purposes, use extreme caution and replace the guards immediately after maintenance is complete.
15. Check damaged parts. Before further use of the machine, a guard or other part that is damaged should be carefully checked to determine that it will operate properly and perform its intended function. Check for alignment of moving parts, binding of moving parts, breakage of parts, mounting and any other conditions that may affect its operation. A guard or other part that is damaged should be properly repaired or replaced.
16. Do not use power tools in damp/wet locations or other dangerous environments. Do not expose them to rain. Keep work area well lighted. Provide for adequate space surrounding work area and non-glare, overhead lighting.
17. Keep the floor around the machine clean and free of scrap material, oil and grease.
18. Keep visitors a safe distance from the work area. Keep children away.
19. Make your workshop child proof with padlocks, master switches or by removing starter keys.
20. Give your work undivided attention. Looking around, carrying on a conversation and "horse-play" are careless acts that can result in serious injury.
21. Maintain a balanced stance at all times so that you do not fall or lean against moving parts. Do not overreach or use excessive force to perform any machine operation. Never force the cutting action.
22. Do not operate the lathe in flammable or explosive environments. Do not use in a damp environment or expose to rain.
23. Use the right tool at the correct speed and feed rate. Do not force a tool or attachment to do a job for which it was not designed. The right tool will do the job better and more safely.



24. Use recommended accessories; improper accessories may be hazardous.
25. Maintain tools with care. Keep cutting tools sharp and clean for the best and safest performance. Follow instructions for lubricating and changing accessories.
26. Do not attempt to adjust or remove tools during operation. Disconnect tools before servicing; when changing accessories, such as blades, bits, cutters, and the like.
27. Never stop a rotating chuck or workpiece with your hands.
28. Choose a low spindle speed when working unbalanced workpieces, and for threading and tapping operations.
29. Do not exceed the maximum speed of the workholding device.
30. Do not exceed the clamping capacity of the chuck.
31. Secure work. For safety and use of both hands, use clamps or a vise to hold work when practical.
32. Workpieces longer than 3 times the chucking diameter must be supported by the tailstock or a steady rest.
33. Avoid small chuck diameters with large turning diameters.
34. Avoid short chucking lengths and small chucking contact.
35. Turn off the machine and disconnect from power before cleaning. Use a brush to remove shavings or debris — do not use your hands.
36. Do not stand on the machine. Serious injury could occur if the machine tips over.
37. Never leave the machine running unattended. Turn the power off and do not leave the machine until moving parts come to a complete stop.
38. Remove loose items and unnecessary work pieces from the area before starting the machine.
39. Direction of feed — feed work into a blade or cutter against the direction of rotation of the blade or cutter only.
40. Installation work and electrical wiring must be done by qualified electrician in accordance with all applicable codes and standards.
41. Tighten all locks before operating.
42. Rotate workpiece by hand before applying power.
43. Rough out workpiece before installing on faceplate.
44. Use lowest speed when starting new workpiece.

**⚠ WARNING:** This product can expose you to chemicals including lead and cadmium which are known to the State of California to cause cancer and birth defects or other reproductive harm. For more information go to <http://www.p65warnings.ca.gov>.

**⚠ WARNING:** Some dust, fumes and gases created by power sanding, sawing, grinding, drilling, welding and other construction activities contain chemicals known to the State of California to cause cancer and birth defects or other reproductive harm. Some examples of these chemicals are:

- lead from lead based paint
- crystalline silica from bricks, cement and other masonry products
- arsenic and chromium from chemically treated lumber

Your risk of exposure varies, depending on how often you do this type of work. To reduce your exposure to these chemicals, work in a well-ventilated area and work with approved safety equipment, such as dust masks that are specifically designed to filter out microscopic particles. For more information go to <http://www.p65warnings.ca.gov/> and <http://www.p65warnings.ca.gov/wood>.

Familiarize yourself with the following safety notices used in this manual:

**⚠ CAUTION**

*This means that if precautions are not heeded, it may result in minor injury and/or possible machine damage.*

**⚠ WARNING**

*This means that if precautions are not heeded, it may result in serious or even fatal injury.*

## 4.0 INTRODUCTION

This manual is provided by JET® covering the safe operation and maintenance procedures for a JET Model E-1340VS and E-1440VS. This manual contains instructions on installation, safety precautions, general operating procedures, maintenance instructions and parts breakdown. Your machine has been designed and constructed to provide years of trouble-free operation if used in accordance with the instructions as set forth in this document.

If there are questions or comments, please contact your local supplier or JET. JET can also be reached at our web site: [www.jettools.com](http://www.jettools.com). Retain this manual for future reference. If the machine transfers ownership, the manual should accompany it.

## 5.0 SPECIFICATION AND ACCESSORIES

### 5.1 GENERAL LAYOUT OF LATHE

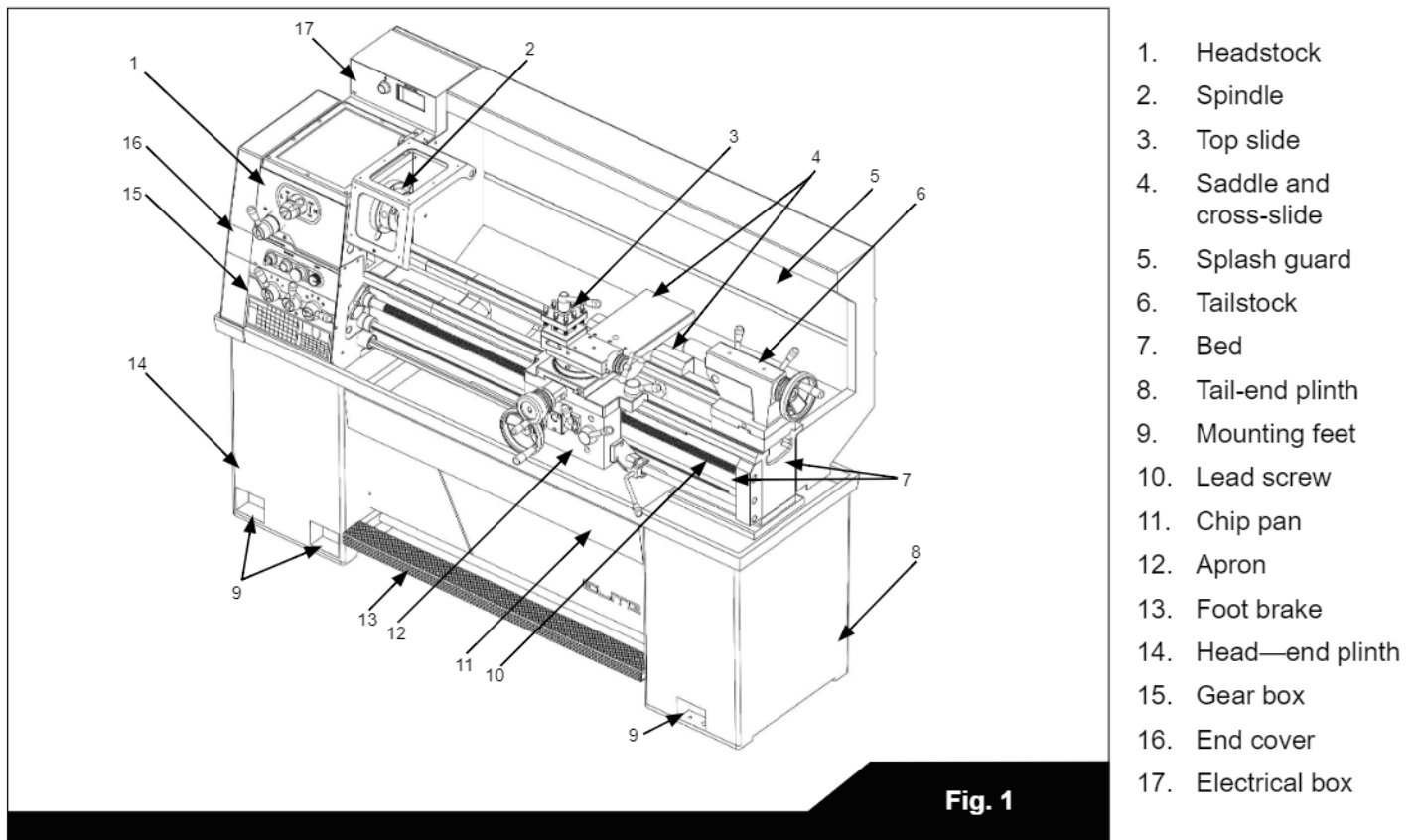

## 5.2 DIMENSIONS

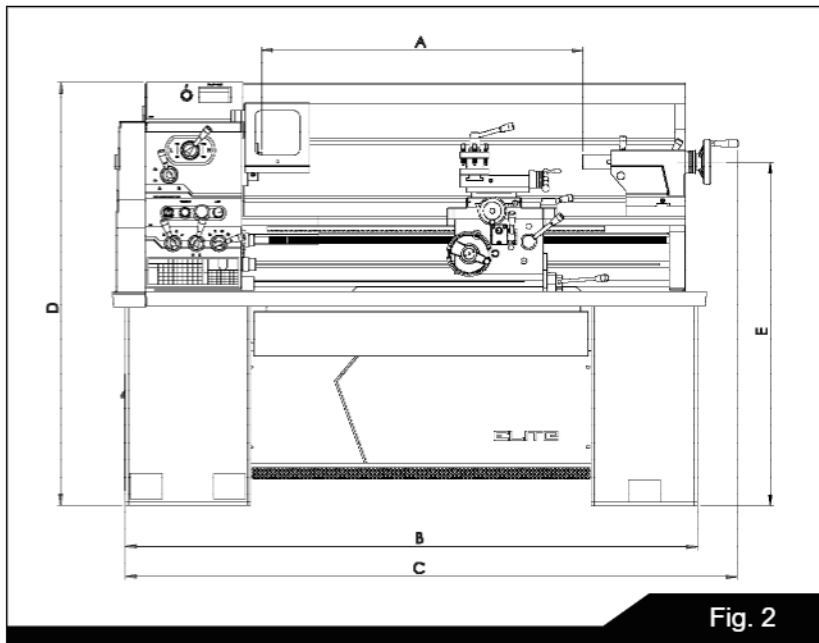

Fig. 2

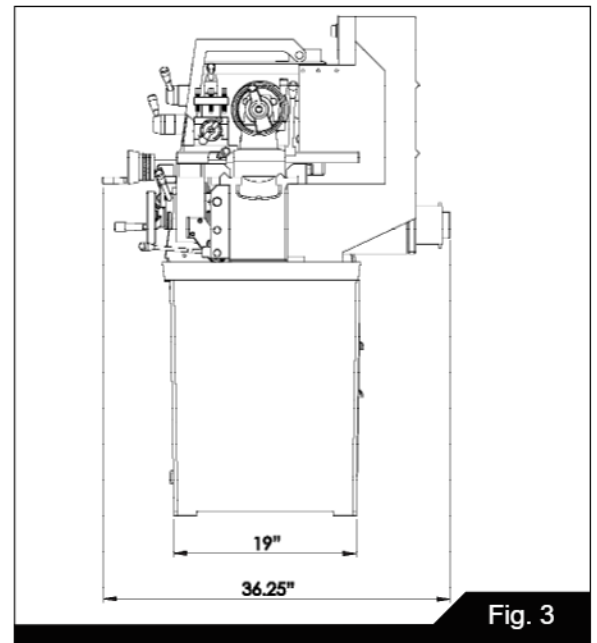

Fig. 3

Model	A	FB	C	D	E
E - 1340VS	40"	71"	75.5"	51"	41.5"
E - 1440VS	40"	71"	75.5"	51"	42"

## 5.3 FOUNDATION PLAN

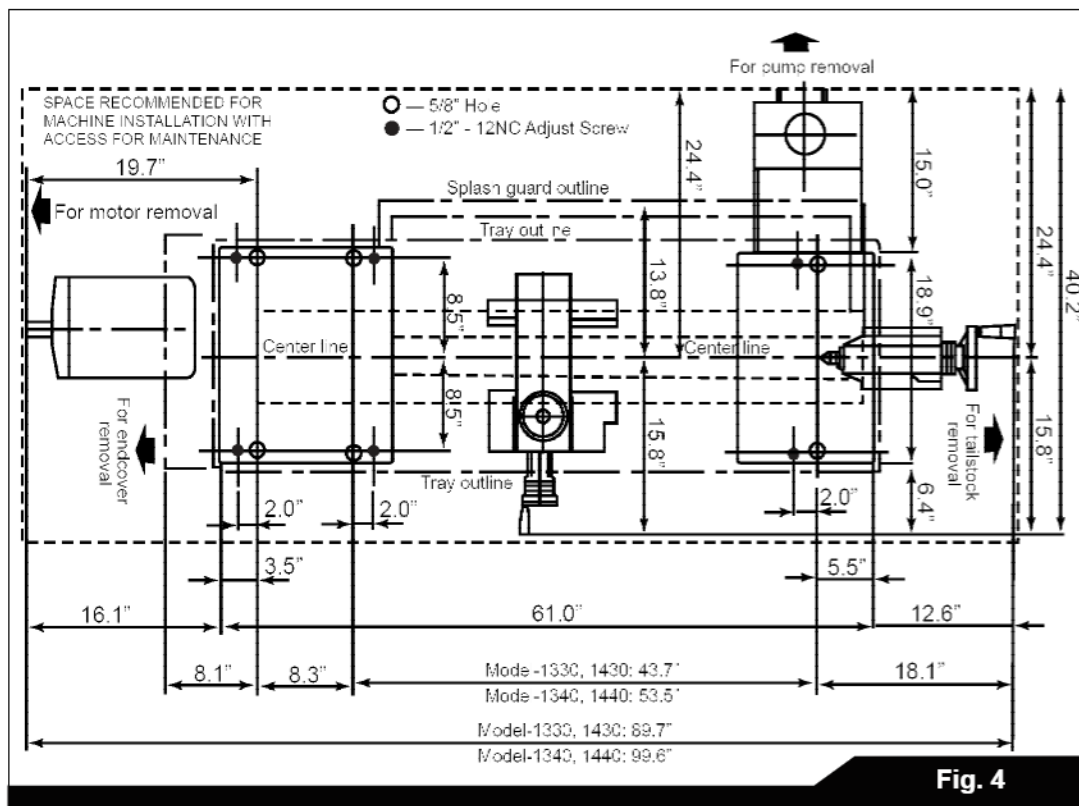

Fig. 4

## 5.4 SPECIFICATIONS AND ACCESSORIES

MODEL		1340VS	1440VS
<b>NOMINAL SIZE</b>			
Swing over Bed		330mm (13in)	356mm (14in)
Swing over Cross Slide		195mm (7-5/8in)	220mm (8-5/8in)
Height of Center		165mm (6-1/2in)	178mm (7in)
Distance between Centers		1000mm (40in)	1000mm (40in)
<b>BED</b>			
Width of Bedways		206mm (8-1/2in)	206mm (8-1/2in)
Total Length of Bed		1680mm (66in)	1680mm (66in)
Gap Type	Swing over Gap	490mm (19in)	515mm (20in)
	Length of Gap	240mm (9-7/16in)	240mm (9-7/16in)
	Width in front of face plate	146mm (5-3/4in)	146mm (5-3/4in)
<b>SPINDLE</b>			
Spindle nose mounting		D1-4 Camlock	
Spindle bore		38mm 1-1/2in	
Taper of spindle bore		MT5	
Number of spindle speeds		Variable speed change	
Range of spindle speeds		30-2200 R.P.M	
<b>TOOL SLIDE</b>			
Total travel of cross slide		160mm (6-1/4in)	165mm (6-1/2in)
Total travel of top slide		90mm (3-1/2in)	100mm (4in)
Max. size cutting tool		16mm (5/8in)	22mm (7/8in)
<b>TAIL STOCK</b>			
Total travel of tailstock barrel		120mm (4-3/4in)	
Taper in tailstock barrel		MT3	
Diameter of barrel		45mm (1-3/4in)	
<b>THREADS</b>			
Lead screw diameter & pitch		Dia. 7/8in Pitch 1in/8 T.P.I	
Number of Inch threads		40	
Range of Inch threads		4-112 T.P.I.	
Number of Metric threads		22	
Range of Metric threads		0.45-7.5 mm	
<b>FEEDS</b>			
Feed rod diameter		19mm (3/4in)	
Number of feed change		40 Longitudinal / 40 Crossfeed	
Range of Longitudinal feeds		0.0012-0.0294 in/rev.	
Range of Cross feeds		0.0005-0.0271 in/rev	
<b>MOTOR</b>			
Main spindle motor		3HP (2.2KW)	
Coolant pump motor		1/8HP (0.175KW)	
Machine net weight		700kgs (1543lbs.)	750kgs (1654lbs.)
<b>We reserve the right to modify and improve our products.</b>			



## 6.0 INSTALLATION

### 6.1 LIFTING

Use the sling-chain to sling lathe as shown in Figure 5 position the saddle and tailstock along the bed to obtain balance.

**Note: Do not use slings around bed as leadscrew and feedshaft may be bent.**

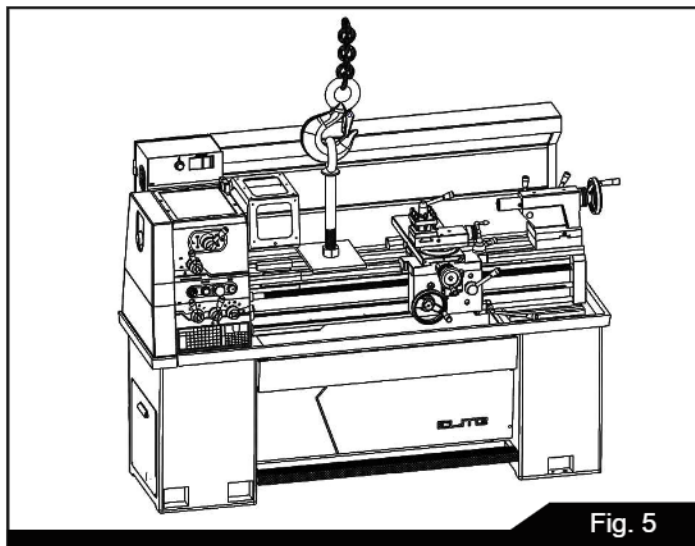

Fig. 5

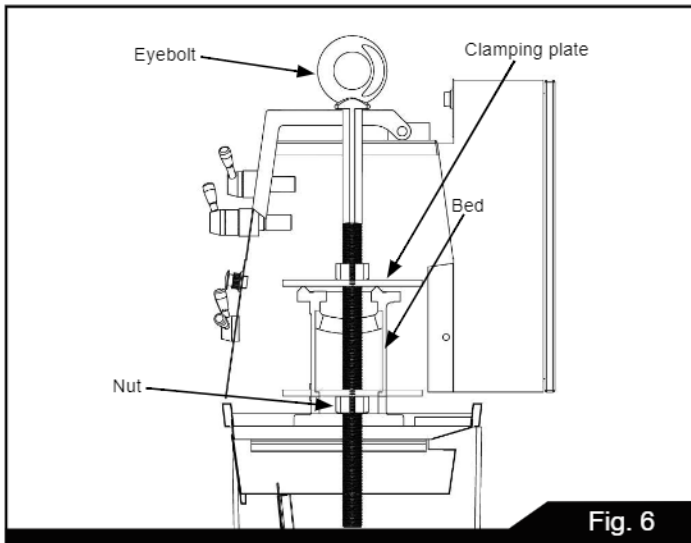

Fig. 6

### 6.2 CLEANING

Before operating any controls, use white spirit or kerosene to remove the anticorrosion coating from all slideways and the endgear train.

Do not use cellulose solvents for cleaning as they will damage the paint finish.

Machine surface becomes bright immediately after cleaning using machine oil or slideway lubricant. Use heavy oil or grease on the end gears.

### 6.3 INSTALLING

Place the machine on a solid foundation, allowing sufficient area all around for easy working and maintenance (see Foundation Plan). The lathe may be used free-standing or bolted to the foundation.

**Free-standing:** Position the lathe on foundation and adjust each of the six mounting feet to take equal share of the load. Then using an engineers precision level on the bedways (as in Figure 7) adjust the feet to level up machine. Periodically check bed level to ensure continued Lathe accuracy.

**Fixed installation:** Position lathe over six bolts (1/2 inch or 12 mm. diameter), set into the foundation to correspond with holes in the mounting feet. Accurately level the machine as in Figure, then tighten hold-down bolts and recheck bed level.

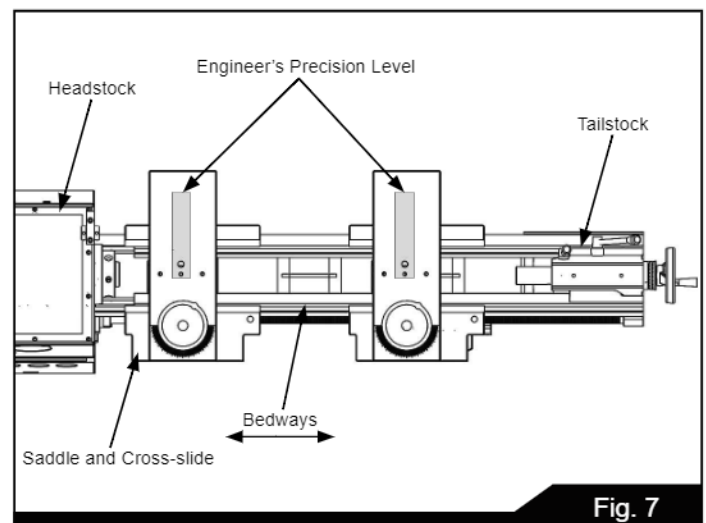

Fig. 7



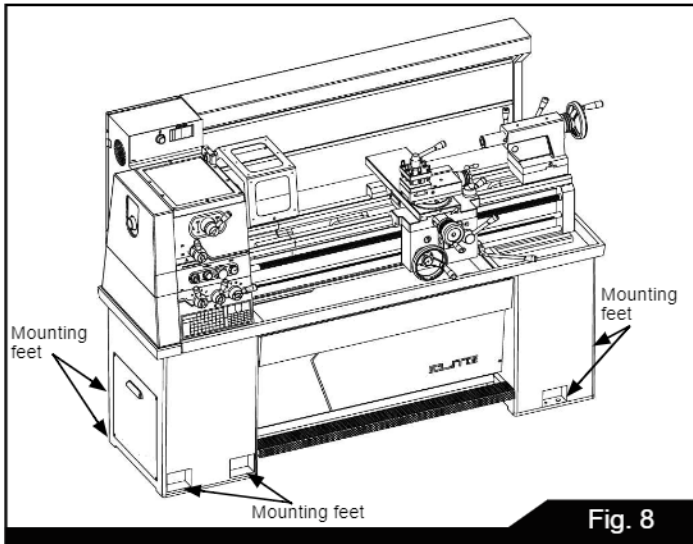

Fig. 8

## 6.4 LUBRICATION CHECKS

Before operating the machine make the following important checks:

1. That the headstock is filled to level marked on oil sight window with Shell Tellus Oil 27.
2. That the gearbox is filled to level marked on oil sight window with Shell Tellus Oil 27.
3. That the carriage apron is filled to level mark on oil sight window with Shell Tonna 33.
4. In addition, apply an oil can to the points shown on lubrication diagram which require daily oiling. Use light machine oil or way lubricant.

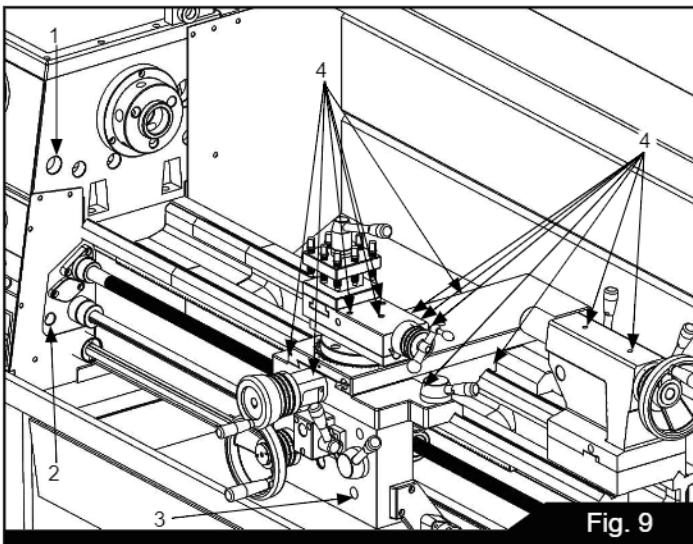

Fig. 9

## 6.5 CHUCKS AND CHUCK MOUNTING

### ⚠ WARNING

**Grey-iron chucks must not be fitted on this high-speed lathe. Use only ductile iron chucks.**

When mounting chucks or faceplate, first, ensure that spindle and chuck tapers are thoroughly cleaned and that all cams lock in the correct positions, see figure. It may be necessary when mounting a new chuck to reset the camlock studs (A). To do this, remove the caphead locking screws (B) and set each stud so that the scribed ring (C) is flush with the rear face of the chuck - with the slot lining up with the locking screw hole (see Fig 10).

Now mount the chuck or faceplate on the spindle nose and tighten the three cams in turn. When fully tightened, the cam lock line on each cam should be between the two V marks on the spindle nose.

If any of the cams do not tighten fully within these limit marks, remove the chuck or faceplate and readjust the stud as indicated in the illustration. Fit and tighten the locking screw (B) at each stud before remounting the chuck for work.

This will assist subsequent remounting.

**Note: Do not interchange chucks or faceplates between lathes without checking for correct cam locking beforehand.**

**Note: Take careful note of speed limitation when using faceplate; 10 inch faceplates should not be run at speeds greater than 1000 rev/min and 12 inch faceplates at not more than 770 rev/min.**

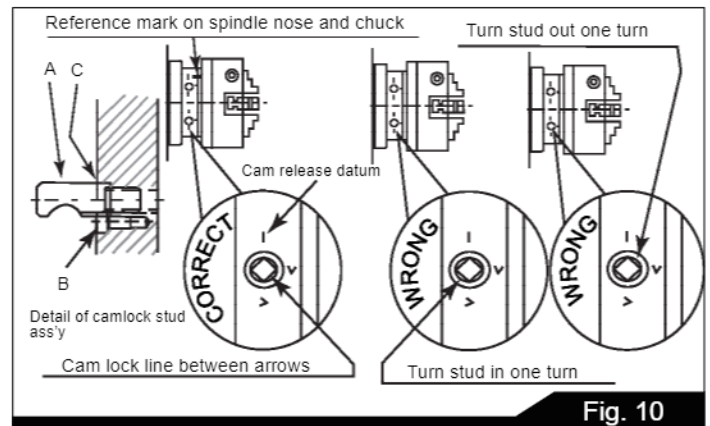

Fig. 10

**Chuck Key Bracket:** The chuck key bracket (Figure 10A) is located on the cabinet below the headstock. The chuck key must be placed within the bracket for lathe to operate. A sensor in the bracket will deactivate spindle if key is not present - this ensures key has been safely removed from chuck and spindle area before starting the lathe.

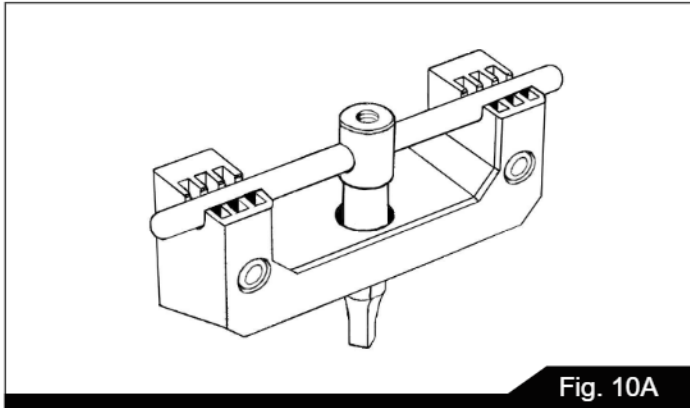

Fig. 10A

## 7.0 OPERATION

### 7.1 LATHE CONTROL

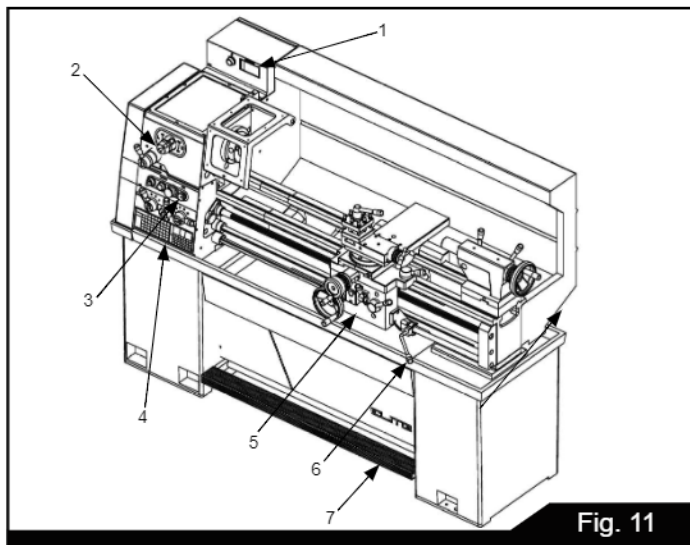

Fig. 11

1. Spindle speed digital readout. (for V-speed)
2. Spindle speed selector (HIGH or LOWER step).
3. Spindle speed adjusting knob. (for V-speed)
4. Gearbox, threads and feeds.
5. Apron, surfacing or sliding feeds.
6. Main motor rotation (forward and reverse).
7. Footbrake

### 7.2 ELECTRICAL CONTROLS

The *main power switch* is located on the *electrical box* behind the *lathe* (head - end).

All electrical controls are fitted to the front face of the *headstock* and the top of *electrical box* on the top of *headstock*.

- (1) **POWER SWITCH:** when the main power switch (1) on the electrical cover is turned on, the pilot lamp (2) glows and the electricity is on. (See Figure 13).
- (2) **POWER INDICATOR LIGHT:** When the power is on, the indicator light glows.
- (3) **EMERGENCY STOP SWITCH:** press the RED mushroom - head button to stop electric power, to stop the main motor and coolant pump.
- (4) **JOG BUTTON:** Press the GREEN button to move spindle slightly, it will make spindle speed selection very easy. (While the spindle rotation lever is set in the neutral position).
- (5) **VARIABLE SPEED SELECTORS:** adjusting spindle speed.
- (6) Spindle speed chart.
- (7) Coolant pump ON/OFF switch.
- (8) End cover switch: While operating open end cover door for adjustment or maintenance, it will stop automatically all rotation movements.

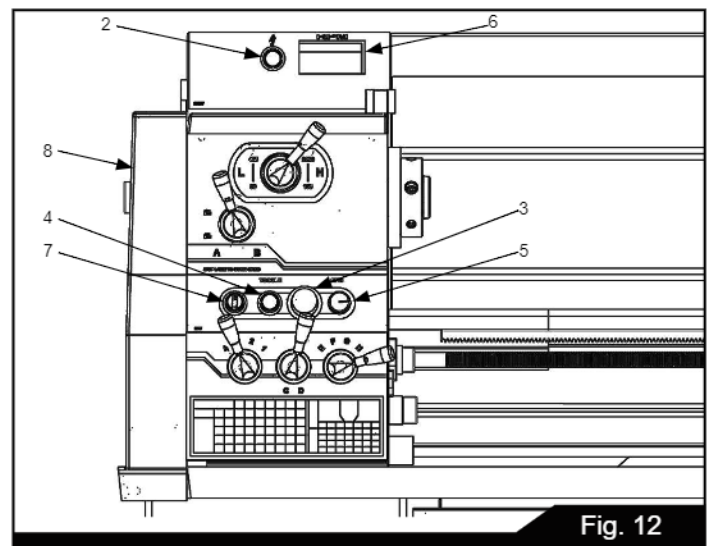

Fig. 12

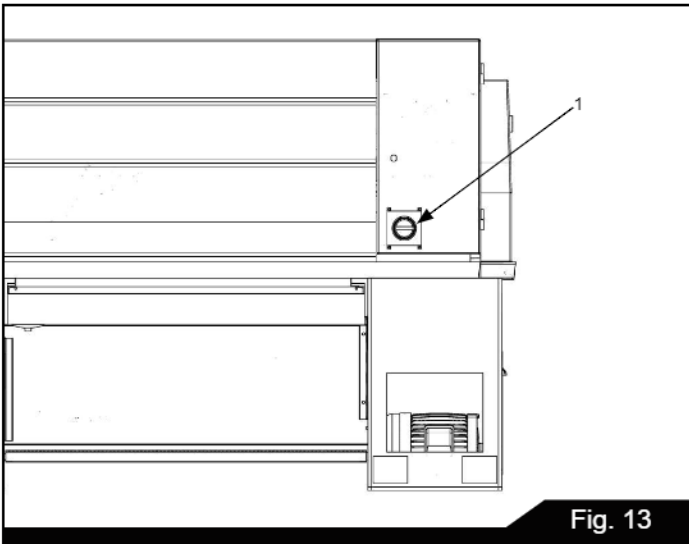

Fig. 13

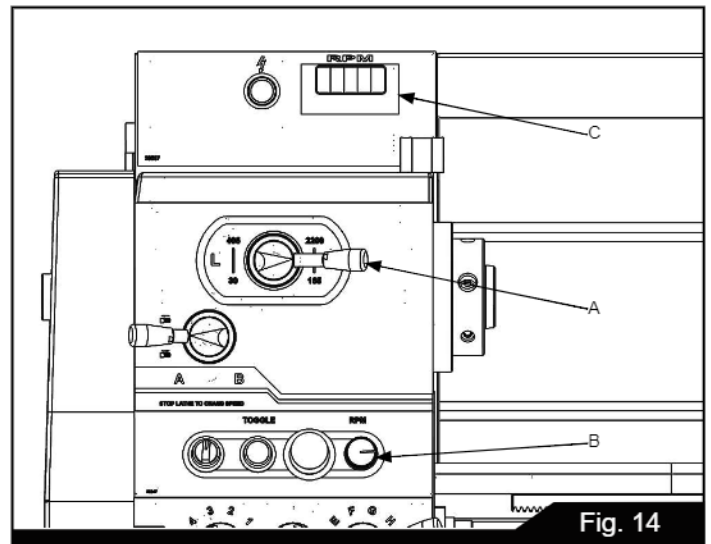

Fig. 14

**HIGH SPEED (165-2000 RPM)**

### 7.3 SPINDLE SPEED SELECTORS

Main spindle is variable from 40-2000 rpm, divided into two groups. Spindle speed is divided into two groups, low and high speed. Low speed ranges from 40 - 405 rpm, and High speed ranges from 165 - 2000 rpm..

First, put the upper right-hand handle (A) on the Headstock to needed speed range.

**Note: Don't change handle's position with spindle in motion. Spindle must be motionless when changing the handle's position.**

Then, adjust Variable Speed Selector (B) to needed spindle speed. Selectors (B) can change speed while spindle is rotating.

Spindle Speed Chart (C) equipped on the face of the Headstock shows the RPM while spindle is rotating.

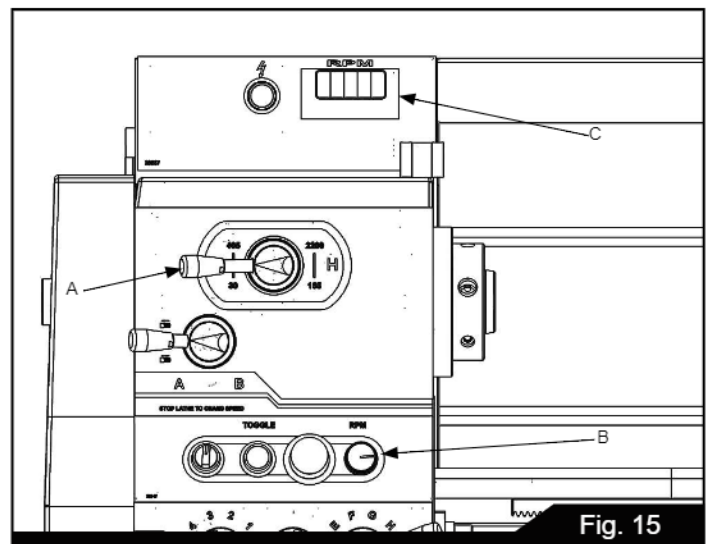

Fig. 15

**LOWER SPEED (40-405 RPM)**

### 7.4 THREADS AND FEEDS

All the threads and feeds directly available from the gear box are shown in the data plate fitted on the front of the gearbox. The setting of control levers is shown below.

The B position of lever (Y) can provide a range of fine threads; the A position a coarse thread range. Do not select the range (A position) at spindle speeds higher than 770 rev/min.



Threads available:

- 37 Metric threads - 0.5 to 7.0mm pitch
- 40 STD. threads - 4 to 112 T.P.I.

The endgear train should be arranged as in the diagrams shown on the data plate to suit threading requirements.

Feed rates: The Cross feed rate is 50% of Longitudinal feed that is shown on headstock.

Feeds: longitudinal feeds per spindle revolution range from 0.053 to 0.402mm.

Cross feeds per spindle revolution range from 0.026 to 0.201mm.

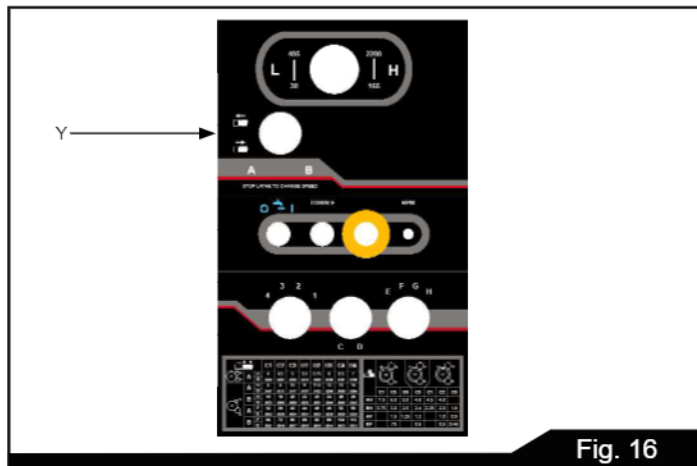

Fig. 16

## 7.5 THREADING DIAL INDICATOR

### STD. threads

Located on the right hand side of the apron on lathes having an English leadscrew. Engage the indicator pinion with the leadscrew and tighten the handnut to retain indicator in engagement. To cut threads of an even number per inch, close the leadscrew nut as ANY line on the dial passes the datum mark. To cut threads of odd numbers per inch, close the leadscrew nut at any NUMBERED line.

Fractional threads of 1/2 or 1/4 t.p.i. may be cut by closing the nut at the SAME numbered line on each pass of the tool.

This dial cannot be used with an English leadscrew to cut metric threads, or fractional threads. For these the leadscrew nut must be kept closed and the machine reversed by use of the changeover switch, after each cutting pass and tool withdrawal.

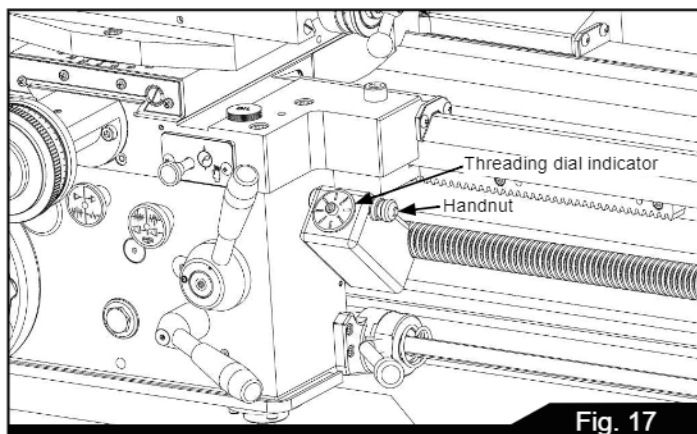

Fig. 17

## 7.6 APRON CONTROLS (LEVER TYPE)

In addition to handwheel traverse, the carriage can be power-operated through controls on the front of the apron, see Figure 16 knob (A). Automatic feed lever (A) if moved upwards, the carriage will do longitudinal-feed operation. If the lever (A) is placed in middle position, it will perform manual operation. If the lever (A) is moved downward, it will perform the cross-feed operation.

Lever (B) is pressed downward to engage the leadscrew nut for threading. To avoid undue wear, release the nut except when threading.

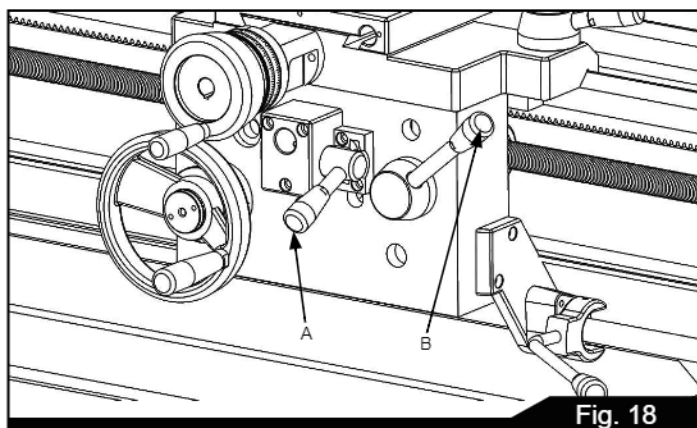

Fig. 18

## 7.7 CROSS SLIDE AND TOP SLIDE

A solid topside is fitted as standard to the cross-slide. Carried on a rotatable base the cross-slide is marked 45-0-45 degrees for accurate indexing.

Handwheel dials are graduated in inch or metric division to suit the operating screw and nut fitted.

The cross-slide can be power operated by pulling out the hand knob (A), at one-third feed per spindle revolution, or it can be hand-operated using the large-diameter dial graduated in either inch or metric divisions to suit the operating screw and nut fitted.

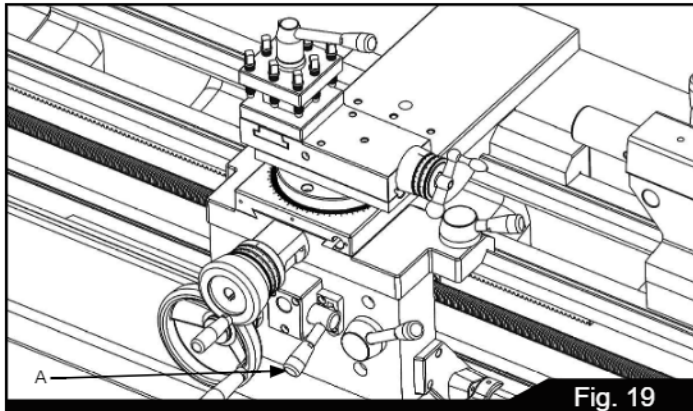

Fig. 19

## 7.8 TAIL STOCK

Can be freed for movement along the bed by unlocking the clamp lever (A). The tailstock barrel is locked by lever (B).

The tailstock can be offset for production of shallow tapers or for re-alignment. Release the clamping lever (A) and adjust screws (S) at each side of the base to move tailstock laterally across the base. An indication of the offset is given by the datum mark (C) at the tailstock end face, as shown in Figure 18. Apply clamp lever after adjustment of set-over.

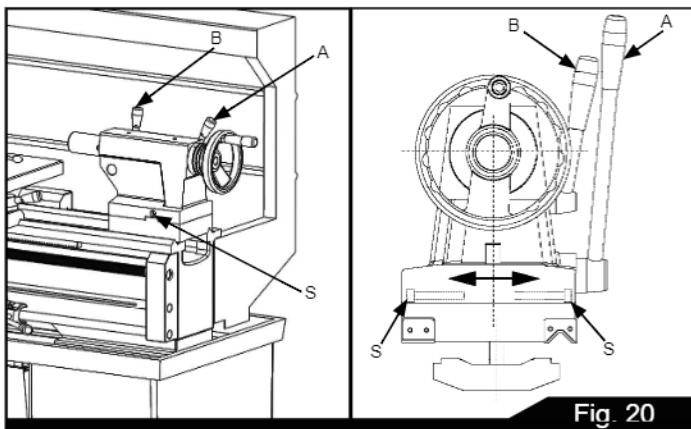

Fig. 20

## 8.0 SERVICING AND MAINTENANCE

### 8.1 LATHE ALIGNMENT (PART 1)

With the lathe installed and running, we recommend a beginning check of the machine alignment before work. Check leveling and machine alignment at regular periods to ensure continued lathe accuracy.

**Headstock check:** Take a light cut with a sharp tool over a 6 inch (150 mm) length of a 2 inch diameter (50 mm) steel bar gripped in the chuck but not supported at the free end. Micrometer readings at each end of the turned length (See Figure 22) should be the same.

To correct a difference in readings, loosen the four headstock hold-down screws (J) shown in Figure 21 and adjust the set-over pad (K) beneath the headstock. Then tighten all screws. After adjustment, repeat the test-cut/micrometer reading until micrometer readings are identical so that machine cutting will be absolutely parallel.

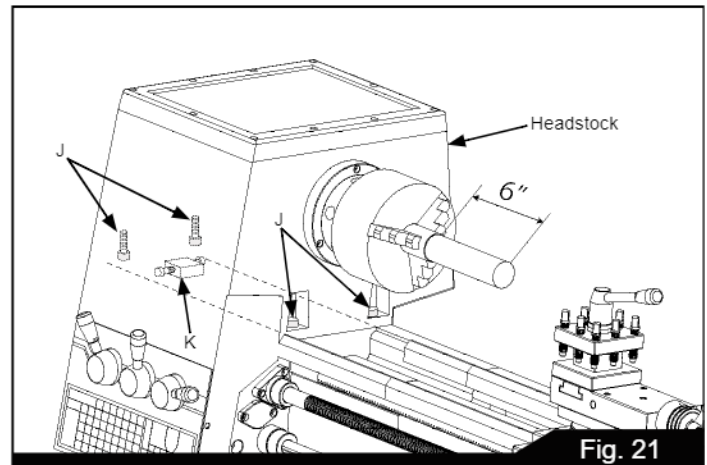

Fig. 21

### 8.2 LATHE ALIGNMENT (PART 2)

#### B. Tailstock check

Using a 12 inch (305 mm) ground steel bar fitted between headstock and tailstock centers, check the alignment by fitting a dial-test indicator to the topline and traversing the center line of the bar.

To correct error, release the tailstock clamp lever and adjust the two set-over screws provided. Continue with checking and correction until the alignment is perfect.

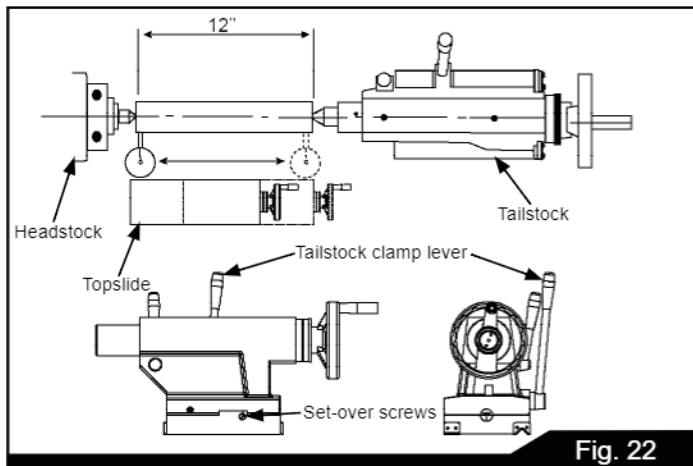

Fig. 22

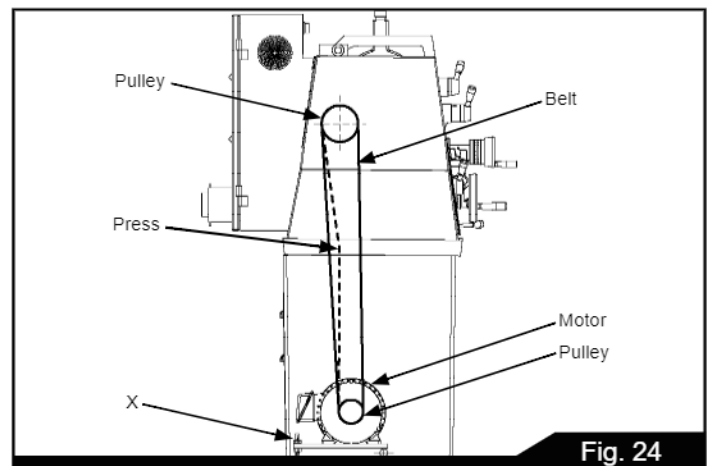

Fig. 24

### 8.3 END GEAR TRAIN

Drive from headstock to gearbox is transmitted through a gear train enclosed by the headstock end-guard. Intermediate gears are carried on an adjustable swing frame (M).

Gears must be thoroughly cleaned before fitting and backlash maintained at 0.005 in. (0.127mm). Lubricate gears regularly with thick oil or grease.

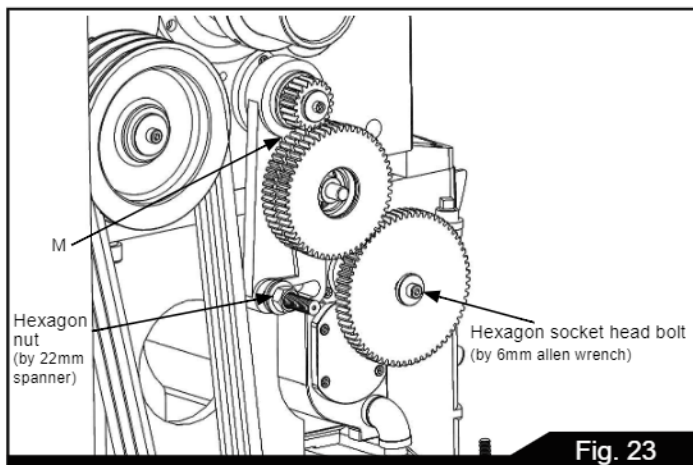

Fig. 23

### 8.4 DRIVING BELTS

To alter belt tension, remove the coverplate in back of the headstock and adjust the two screws (X) on the hinged motor platform. Ensure that the motor is correctly aligned with the lathe axis.

Light finger pressure at a point midway between motor and headstock pulleys about 3/4 in. (19mm) movement of each belt when under correct tension.

### 8.5 SLIDE WAYS ATTENTION

Tapered gib strips are fitted to slideways of saddle cross-slide and top (compound) slides so that any slack which may develop can be justified.

Ensure that slideways are thoroughly cleaned and lubricated before attempting adjustment. Then reset the gibs by loosening the rear gib screw and tightening the front screw. Check constantly for smooth action throughout full slide travel; avoid overadjustment which can result in increased wear-rate and stiff or jerky action.

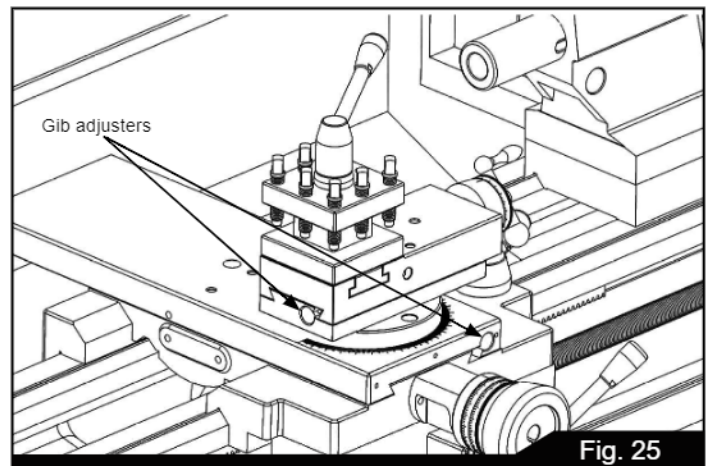
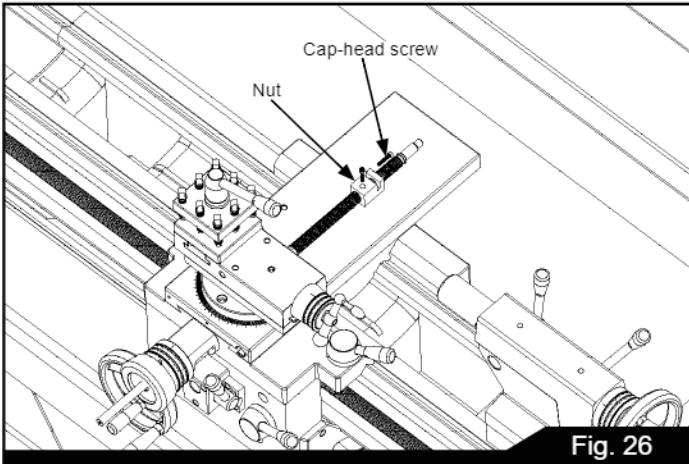

Fig. 25

### 8.6 CROSS-SLIDE NUT

This is adjustable for elimination of slack which may develop in service. Reduce backlash by the cap-head screw in the rear of the nut, then make only small adjustments by the cap-head screw. Before operating the cross-slide, check several times by hand to ensure smooth operation throughout travel.





### 8.8 LUBRICATION (PART 2)

In addition, an oil gun is provided for the saddle, cross-slide, cross-slide nut and top-slide (compound slide) to oil. Leadscrew using an oil gun can be oiled with light machine oil or way lubricant.

On the tailstock, oil points are provided for daily attention from a standard oil can.

It is recommended that all slideways, leadscrew and feed shaft are cleaned off (a bristle paint brush is useful for this) and lightly oiled after each period of work.

**Note: Using incorrect grade of oil can cause damage.**

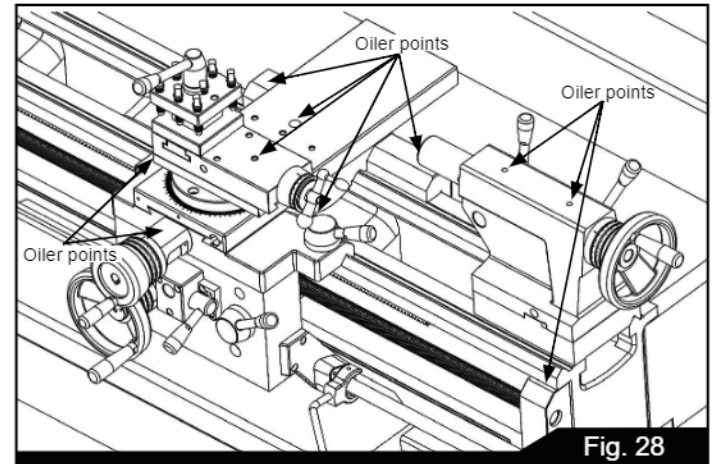

### 8.7 LUBRICATION (PART 1)

The headstock and gearbox are splash-lubricated from an internal reservoir of oil (Shell Tellus 27). Check the oil level constantly to the mark on the oil sight window in the front end face of the headstock and gearbox. A weekly check is recommended. The oil should be changed every year. Add oil through a filler cap in the top of the headstock and gearbox is covered by the end-guard. Drain from a drain plug in the bottom of the headstock and gearbox.

The apron is lubricated from an internal reservoir of oil. The oil sight window is in the front of the apron. A filler cap is in the top of the saddle. Refill the reservoir to the level of the oilsight with Shell Tonna oil 33. The apron can be drained by unscrewing a hexheaded drain plug in the bottom.

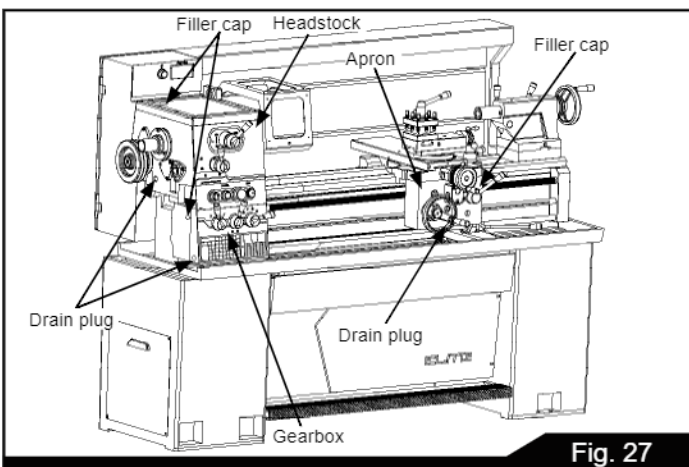



## 8.9 LUBRICATION DIAGRAM

Part to be lubricated		1. Headstock	2. Gearbox	3. Apron	4. Slide and Tailstock
Recommendable lubricant		SHELL; TELLUS OIL 27	SHELL; TELLUS OIL 27	SHELL; TELLUS OIL 33	SHELL; TELLUS OIL 33 - 41
Filling method		OIL JUG	OIL JUG	OIL JUG	OIL GUN
Initial charge quantity		4.5 liter	1.5 liter	0.9 liter	—
Make up	Interval	3 Month	3 Month	1 Month	1 Day
	Quantity	0.5 Liter	0.5 Liter	0.2 Liter	A little
Exchange	Interval	1 Year	1 Year	1 Year	—
	Quantity	4.5 Liter	1.5 Liter	0.9 Liter	—

## 9.0 RECOMMENDED CUTTING SPEED OF LATHE

Workpiece material		Speed (sfm)	Feed (lpr)
Aluminum	2021 to 6061	500	0.002
Brass		75	0.001
Bronze		70	0.001
Cast Iron	Gray	35 to 125	0.0015 to 0.004
	Ductile	15 to 125	0.001 to 0.004
	Malleable	35 to 170	0.0015 to 0.003
Copper	101 to 757	85 to 90	0.002
	834 to 978	340	0.003
Magnesium	AZ, AM, EZ, ZE, HK types	500	0.002
Nickel	Nickel 200 to 230	85	0.002
	Monel	15 to 60	0.001 to 0.0015
	Inconel, Waspaloy	15	0.002
	Hastelloy	10 to 15	0.002
Plastic	TFE, CTFE	250	0.002
	Nylon	350	0.002 to 0.003
	Phenolic	350	0.003
Stainless Steel	201 to 385	65 to 85	0.001 to 0.0015
	405 to 446	90	0.0011
	15-5 PH, 16-6 PH, 14-4 PH	30 to 60	0.0006 to 0.0012
Steel	1005 to 1029	80 to 140	0.001 to 0.002
	1030 to 1055	35 to 115	0.0009 to 0.0015
	1060 to 1095	30 to 80	0.0007 to 0.001
	10L45 to 10L50	40 to 140	0.0009 to 0.0015
	12L13 to 12L15	225 to 280	0.003 to 0.0035
	41L30 to 41L50	20 to 110	0.0007 to 0.0015
	4140 to 4150	20 to 115	0.0007 to 0.0015
	4140 (35 HRC)	70	0.001
	8617 to 8622	40 to 120	0.001 to 0.0016
	M-1 to M-6	60	0.0013
	H-10 to H-19	20 to 80	0.007 to 0.0011
	D-2 to D-7	45 to 60	0.001
	A-2 to A-9, 01 to 07	45 to 60	0.001
	W-1, W-2	110	0.0015
	M-50, 52100	20 to 85	0.0007 to 0.0015
Titanium	TI-6Al-6V	45	0.001



---

## **10.0 REPLACEMENT PARTS — E-1340VS, E-1440VS**

Replacement parts are listed on the following pages.  
To order parts or reach our service department, call  
1-855-336-4032, Monday through Friday, 8:00 a.m. to 5:00  
p.m. CST. Having the Model Number and Serial Number of  
your machine available when you call will allow us to serve  
you quickly and accurately.

JET®

427 New Sanford Road

LaVergne, Tennessee 37086

[www.jettools.com](http://www.jettools.com)

Phone: 855-336-4032

**HEADSTOCK ASSEMBLY**

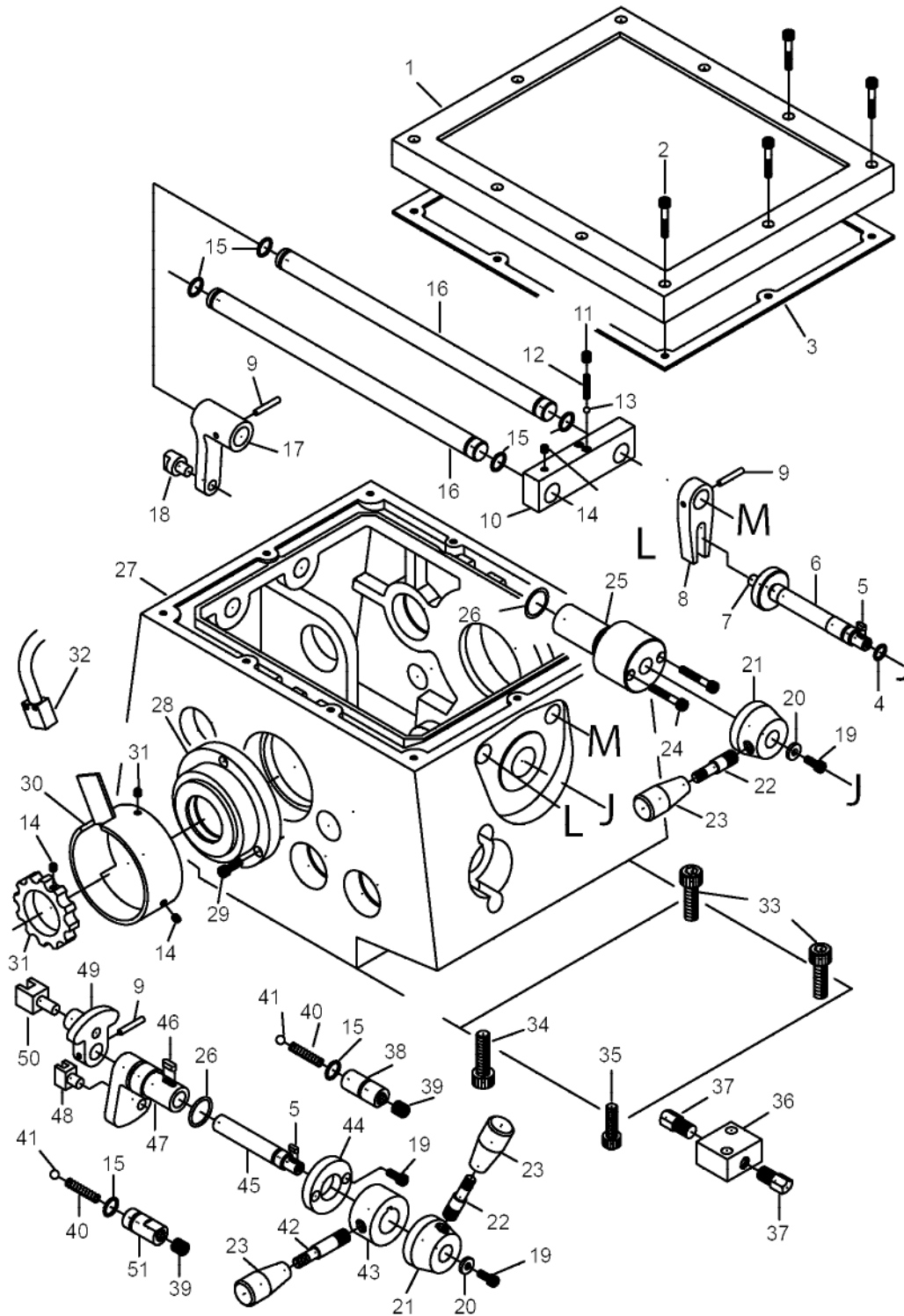

# HEADSTOCK ASSEMBLY

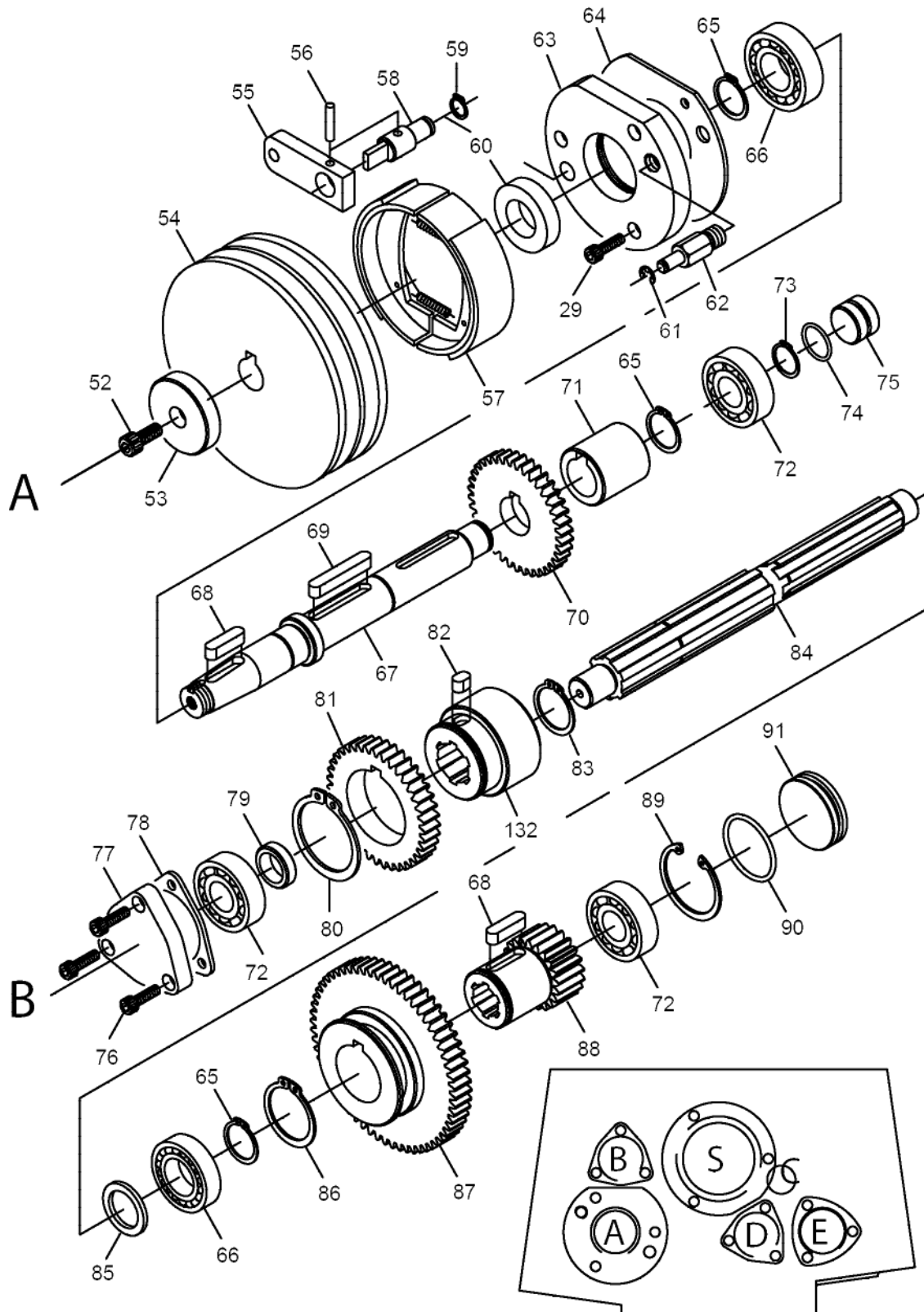







## HEADSTOCK ASSEMBLY PARTS LIST

Index No.	Part No.	Description	Size	Qty.
1	E1340VS-A01	Cover	355L*299W*30H	1
2	TS-1503081	Socket Head Cap Screw	M6*35mm	10
3	E1340VS-A03	Gasket		1
4	E1340VS-A04	O-Ring	11*16*2.5 mm.	1
5	E1340VS-A05	Key	4*10 mm.	2
6	E1340VS-A06	Shaft	Ø40*132L	1
7	E1340VS-A07	Pin	Ø10*19L	1
8	E1340VS-A08	Lever	Ø19.05	1
9	E1340VS-A09	Pin	5*30 mm.	3
10	E1340VS-A10	Bracket	30W*20T*125L Ø19.05	1
11	TS-1524011	Set Screw	M8*8mm	3
12	E1340VS-A12	Spring	1/4 in.*35mm.	2
13	SB-1/4	Ball Steel	1/4 in. dia.	2
14	TS-1523011	Set Screw	M6*6mm	5
15	E1340VS-A15	O-Ring	14*19*2.5 mm.	6
16	E1340VS-A16	Shaft	Ø3/4**350L	2
17	E1340VS-A17	Shift Lever	Ø19.05	1
18	E1340VS-A18	Shift Fork	Ø19*26.5	1
19	TS-1503031	Socket Head Cap Screw	M6*12mm	7
20	E1340VS-A20	Washer	Ø5/8"Ø1/4**3t	2
21	E1340VS-A21	Handle	Ø50*30L Ø12	2
22	E1340VS-A22	Lever	Ø1/2**50L	2
23	E1340VS-A23	Handle	3/8 in.	3
	E1340VS-A23A	Handle Assy(including #22&23)		1
24	TS-1503101	Socket Head Cap Screw	M6*45mm	2
25	E1340VS-A25	Shaft		1
26	E1340VS-A26	O-Ring	24*30*3.0 mm.	2
27	E1340VS-A27	Main Casting	300L*420W*260H	1
27	E1440VS-A27	Main Casting	300L*420W*273H	1
28	E1340VS-A28	Cover	Ø120*Ø47*45W	1
29	TS-1503041	Socket Head Cap Screw	M6*16mm	12
30	E1340VS-A30	Collar		1
31	E1340VS-A31	Gear		1
32	E1340VS-A32	Speed Sensor	NPN	1
33	TS-1506041	Socket Head Cap Screw	M12*35mm	2
34	TS-1506051	Socket Head Cap Screw	M12*40mm	1
35	TS-1505041	Socket Head Cap Screw	M10*30mm	1
36	E1340VS-A36	Set-Over Pad	40*45*25h	1
37	E1340VS-A37	Screws	17*40L	2
38	E1340VS-A38	Collar	Ø19.05*44L Ø10	1
39	TS-1523041	Set Screw	M6*12mm	2
40	E1340VS-A40	Spring	3/8in *40mm.	2
41	SB-3/8	Ball Steel	3/8 in. dia.	2
42	E1340VS-A42	Lever	Ø1/2**65L	3
	E1340VS-A42A	Handle Assy(including #23&42)		1

Index No.	Part No.	Description	Size	Qty.
43	E1340VS-A43	Collar	Ø50*Ø25*27W	1
44	E1340VS-A44	Collar	Ø54*Ø26*10W	2
45	E1340VS-A45	Shaft	Ø16*160L	1
46	E1340VS-A46	Key	5*15 mm.	2
47	E1340VS-A47	Shift Lever	Ø16*73W	1
48	E1340VS-A48	Shift Fork	14W*20H*26L	1
49	E1340VS-A49	Shift Lever	32W	1
50	E1340VS-A50	Shift Fork	20*20*42L	1
51	E1340VS-A51	Collar	Ø19.05*41L Ø10	1
52	TS-1504041	Socket Head Cap Screw	M8*20mm	1
53	E1340VS-A53	Washer	Ø50.8*12W	1
54	E1340VS-A54	Pulley	Ø151*41L	1
55	E1340VS-A55	Lever	25W*10T*67L	1
56	E1340VS-A56	Pin	5*25 mm.	1
57	E1340VS-A57	Brake		1
58	E1340VS-A58	Stud	Ø16*54L	1
59	E1340VS-A59	Circlip	S-12 mm.	1
60	E1340VS-A60	Oil Seal	TC 25*45*11 mm.	1
61	E1340VS-A61	Circlip	E-6 mm.	1
62	E1340VS-A62	Stud	14*50L	1
63	E1340VS-A63	Cover	Ø110*Ø42*16.4W	1
64	E1340VS-A64	Gasket		1
65	E1340VS-A65	Circlip	S-17 mm.	7
66	BB-6005	Bearing	NO. 6005	3
67	E1340VS-A67	Shaft	Ø32*251L	1
68	E1340VS-A68	Key	8*30 mm.	3
69	E1340VS-A69	Key	8*50 mm.	1
70	E1340VS-A70	Gear	2M 38T	1
71	E1340VS-A71	Collar	Ø38*Ø25*40L	1
72	E1340VS-A72	Bearing	NO. 6204	4
73	E1340VS-A73	Circlip	S-16 mm.	5
74	E1340VS-A74	O-Ring	20*25*2.5 mm.	1
75	E1340VS-A75	Bore Plug	Ø25*18L	3
76	TS-1523051	Set Screw	M6*16mm	3
77	E1340VS-A77	Cover	Ø47*Ø42	1
78	E1340VS-A78	Gasket		1
79	E1340VS-A79	Collar	Ø28*Ø20*8t	1
80	E1340VS-A80	Circlip	S-21 mm.	2
81	E1340VS-A81	Gear	2M 39T	1
82	E1340VS-A82	Key	8*12 mm.	1
83	E1340VS-A83	Circlip	S-18 mm.	1
84	E1340VS-A84	Shaft	Ø30*281L	1
85	E1340VS-A85	Collar	Ø34.9*Ø25*3t	1
86	E1340VS-A86	Circlip	S-19 mm.	2
87	E1340VS-A87	Gear	2M 60T	1
88	E1340VS-A88	Gear	2M 21T	1



Index No.	Part No.	Description	Size	Qty.
89	E1340VS-A89	Circlip	R-47 mm.	1
90	E1340VS-A90	O-Ring	38*45*3.5 mm.	1
91	E1340VS-A91	Bore Plug	Ø47*12W	1
92	E1340VS-A92	Cover		1
93	E1340VS-A93	Gasket		1
94	E1340VS-A94	Nut	Ø75*19W	1
95	BB-30210	Bearing	NO. 30210	1
96	E1340VS-A96	Gear	2M 38T	1
97	E1340VS-A97	Circlip	S-22 mm.	1
98	E1340VS-A98	Gear	2M 43T	1
99	E1340VS-A99	Gear	2M 82T	1
100	E1340VS-A100	Collar	Ø65*Ø55*16.7W	1
101	BB30211	Bearing	NO. 30211	1
102	E1340VS-A102	Gasket		1
103	E1340VS-A103	Cover	Ø150*Ø65*24W	1
104	TS-1503061	Socket Head Cap Screw	M6*25mm	3
105	E1340VS-A105	Spindle	Ø117.5*456.2L	1
106	E1340VS-A106	Key	8*60 mm.	1
107	E1340VS-A107	Cam		3
108	E1340VS-A108	Pin		3
109	E1340VS-A109	Spring	3/16 in.*15mm.	3
110	TS-1504021	Socket Head Cap Screw	M8*12mm	3
111	E1340VS-A111	O-Ring	25*31*3.0 mm.	1
112	E1340VS-A112	Shaft	Ø30*165L	1
113	E1340VS-A113	Gear	2M 21T	1
114	E1340VS-A114	Gear	2M 32T	1
115	E1340VS-A115	Collar	Ø28*Ø20*3W	2
116	E1340VS-A116	Gear	2M 32T	1
117	E1340VS-A117	Cover	Ø47*Ø41	1
118	E1340VS-A118	Gasket		1
119	E1340VS-A119	Key	6*90 mm.	1
120	E1340VS-A120	Shaft	Ø28*162L	1
121	E1340VS-A121	Gear	2M 42T	1
122	E1340VS-A122	Collar	Ø40*Ø25*24W	1
123	E1340VS-A123	Gear	2M 32T	1
124	E1340VS-A124	Collar	Ø40*Ø25*14W	1
125	E1340VS-A125	Gear	2M 32T	1
126	BB-6004	Bearing	NO. 6004	2
127	E1340VS-A127	Oil Seal	TC 25*40*8 mm.	1
128	E1340VS-A128	Cover	Ø30*40W	1
129	E1340VS-A129	Gasket		1
130	E1340VS-A130	Shaft	Ø28*220L:25*21*5	1
131	E1340VS-A131	Gear	2M 38T	1
132	E1340VS-A132	Collar		1

**GEAR BOX ASSEMBLY**

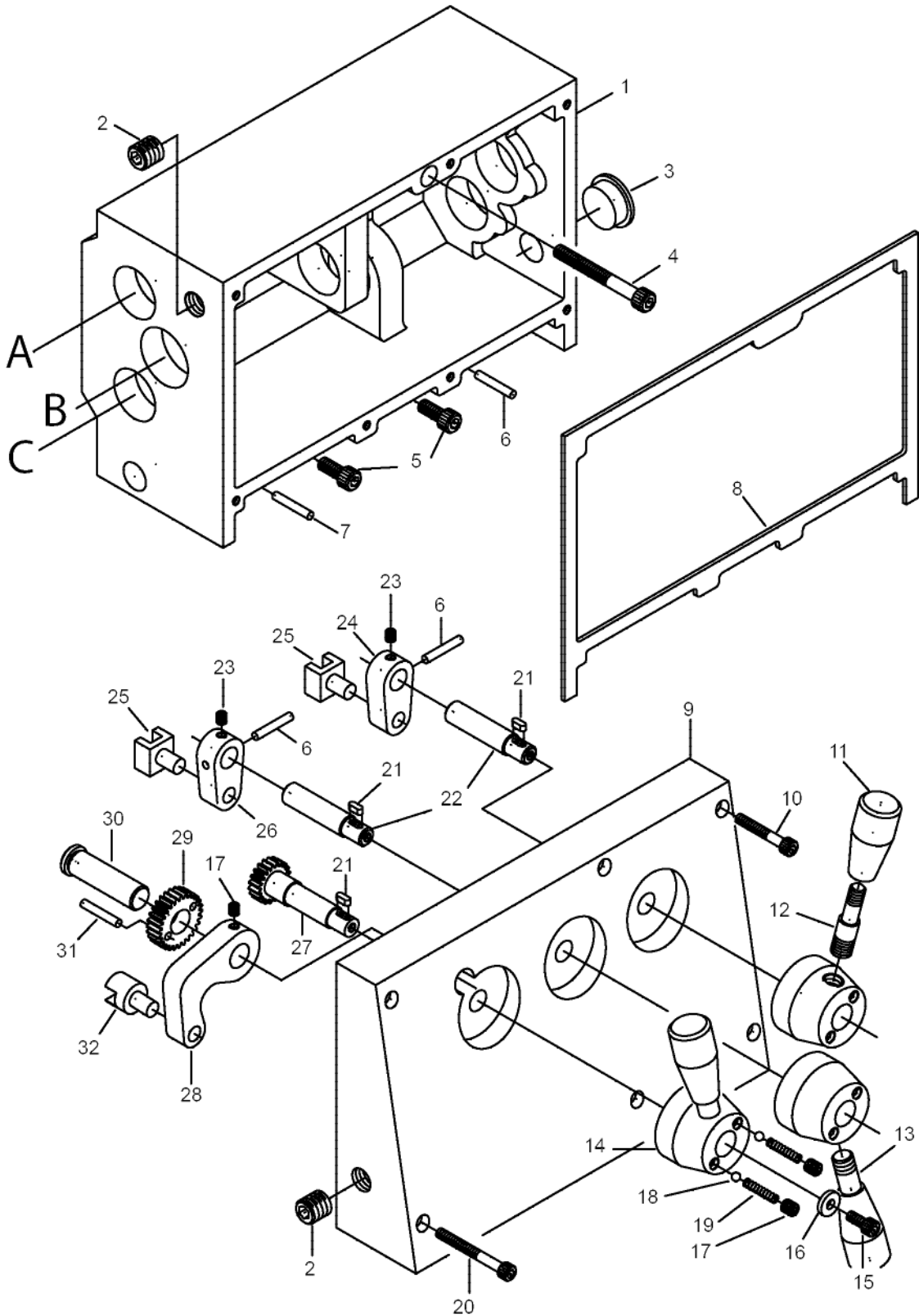



# GEAR BOX ASSEMBLY

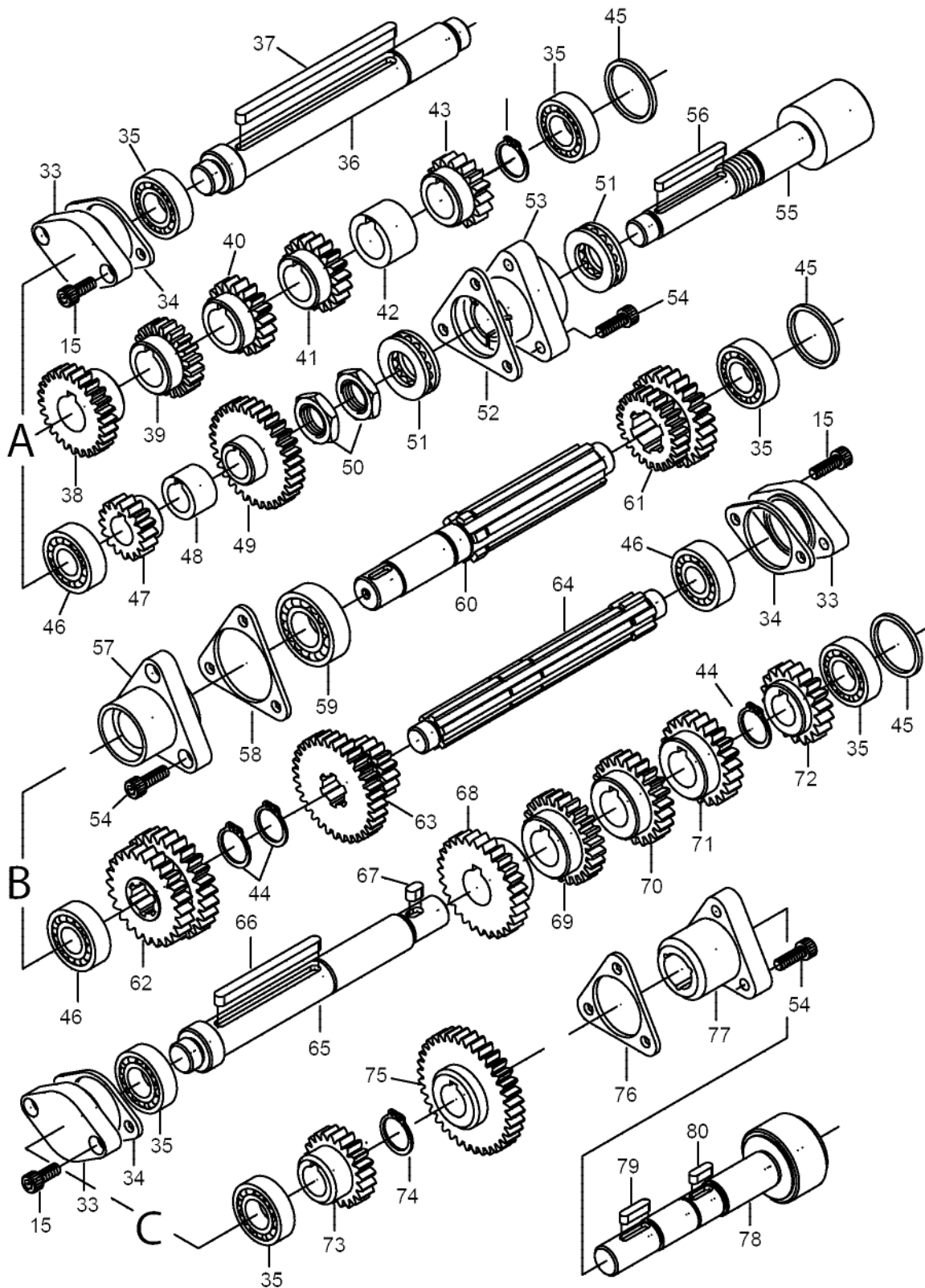



## GEAR BOX ASSEMBLY PARTS LIST

Index No.	Part No.	Description	Size	Qty.
1	E1340VS-B01	Casting	300L*195W*120h	1
2	E1340VS-B02	Plug	3/8 G.P.	2
3	E1340VS-B03	Oil Sight	3/4 in. (19mm.)	1
4	TS-1504131	Socket Head Cap Screw	M8*70mm	1
5	TS-1504041	Socket Head Cap Screw	M8*20mm	2
6	E1340VS-B06	Pin	5*25 mm.	2
7	E1340VS-B07	Pin	5*30 mm.	1
8	E1340VS-B08	Gasket		1
9	E1340VS-B09	Front Cover		1
10	TS-1503091	Socket Head Cap Screw	M6*40mm	10
11	E1340VS-B11	Handle	3/8 in.	3
	E1340VS-B11A	Handle Assy (including #11&12)		1
12	E1340VS-B12	Lever	Ø1/2"*50L	2
13	E1340VS-B13	Lever	Ø1/2"*65L	1
14	E1340VS-B14	Handle	Ø50*35L Ø12	3
15	TS-1503031	Socket Head Cap Screw	M6*12mm	8
16	E1340VS-B16	Washer		3
17	TS-1524011	Set Screw	M8*8mm	7
18	SB-1/4	Ball Steel	1/4 in. dia.	6
19	E1340VS-B19	Spring	1/4 in.*35mm.	6
20	TS-1503121	Socket Head Cap Screw	M6*55mm	4
21	E1340VS-B21	Key	4*10 mm.	3
22	E1340VS-B22	Shaft	Ø14*66L	2
23	TS-1523011	Set Screw	M6*6mm	1
24	E1340VS-B24	Lever	52L*15h	1
25	E1340VS-B25	Fork	20*20*28L	2
26	E1340VS-B26	Lever	15h	1
27	E1340VS-B27	Gear	1.25M 20T	1
28	E1340VS-B28	Lever	15t	3
29	E1340VS-B29	Gear	1.25M 28T	1
30	E1340VS-B30	Shaft	Ø3/4"*59L	1
31	E1340VS-B31	Pin	5*20 mm.	1
32	E1340VS-B32	Fork	Ø20*32L	2
33	E1340VS-B33	Cover	Ø35*Ø31 PCD48*13.4h	3
34	E1340VS-B34	Gasket		3
35	BB-6003	Bearing	NO. 6003	6
36	E1340VS-B36	Shaft	Ø24*189L	1
37	E1340VS-B37	Key	6*115 mm.	1
38	E1340VS-B38	Gear	1.75M 26T	1
39	E1340VS-B39	Gear	2M 20T	1
40	E1340VS-B40	Gear	2M 18T	1



Index No.	Part No.	Description	Size	Qty.
41	E1340VS-B41	Gear	2M 18T	1
42	E1340VS-B42	Collar	Ø30*Ø20*19.5W	1
43	E1340VS-B43	Gear	2M 16T	1
44	E1340VS-B44	Circlip	S-16 mm.	4
45	E1340VS-B45	Gear	2M 23T	3
46	BB-6202	Bearing	NO. 6202	3
47	E1340VS-B47	Gear	1.75M 16T	1
48	E1340VS-B48	Collar	Ø24*Ø16*16W	1
49	E1340VS-B49	Gear	1.75M 32T	1
50	TS-0571082	Nut	6t 3/4"~16NF	2
51	BB-51104	Thrust	NO. 51104	2
52	E1340VS-B52	Gasket		1
53	E1340VS-B53	Cover	PCD54*37W Ø20	1
54	TS-1503041	Socket Head Cap Screw	M6*16mm	9
55	E1340VS-B55	Shaft	Ø36*157	1
56	E1340VS-B56	Key	5*50 mm.	1
57	E1340VS-B57	Cover	36w Ø22	1
58	E1340VS-B58	Gasket		1
59	BB-6004	Bearing	NO. 6004	1
60	E1340VS-B60	Shaft	Ø27*174L 25*21*5	1
61	E1340VS-B61	Gear	1.75M 24T 2M 24T	1
62	E1340VS-B62	Gear	2M 24T 2M 27T	1
63	E1340VS-B63	Gear	1.75M 32T 1.75M 16T	1
64	E1340VS-B64	Shaft	Ø22*176L 20*16*4	1
65	E1340VS-B65	Shaft	Ø25*189L	1
66	E1340VS-B66	Key	6*75 mm.	1
67	E1340VS-B67	Key	6*10 mm.	1
68	E1340VS-B68	Gear	1.75M 28T	1
69	E1340VS-B69	Gear	2M 24T	1
70	E1340VS-B70	Gear	2M 23T	1
71	E1340VS-B71	Gear	2M 22T	1
72	E1340VS-B72	Gear	2M 18T	1
73	E1340VS-B73	Gear	1.75M 21T	1
74	E1340VS-B74	Circlip	S-18 mm.	1
75	E1340VS-B75	Gear	1.75M 36T	1
76	E1340VS-B76	Gasket		1
77	E1340VS-B77	Cover	40W Ø20	1
78	E1340VS-B78	Gear	Ø42*145L	1
79	E1340VS-B79	Key	5*20 mm.	1
80	E1340VS-B80	Key	5*15 mm.	1

**APRON ASSEMBLY**

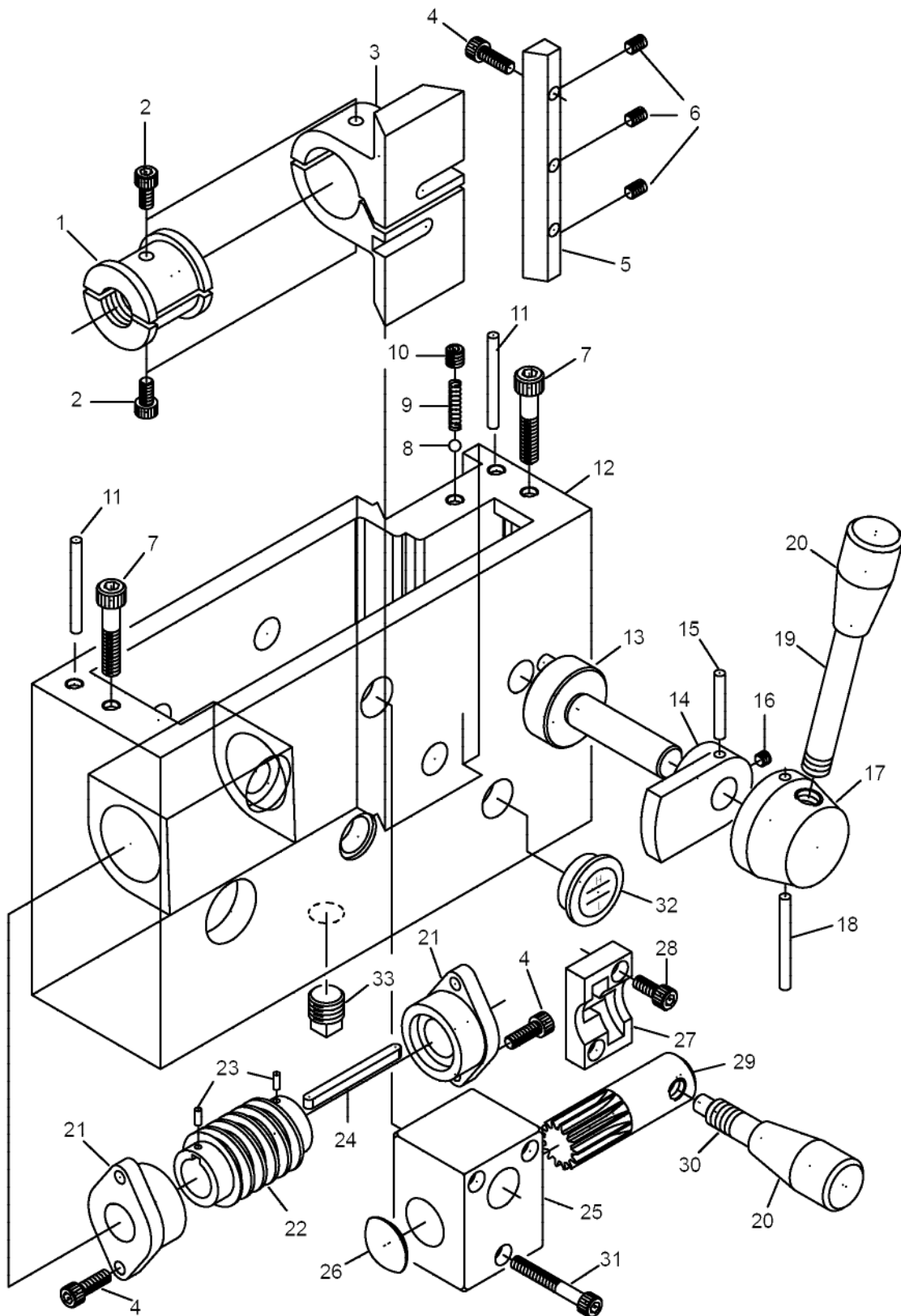

# APRON ASSEMBLY

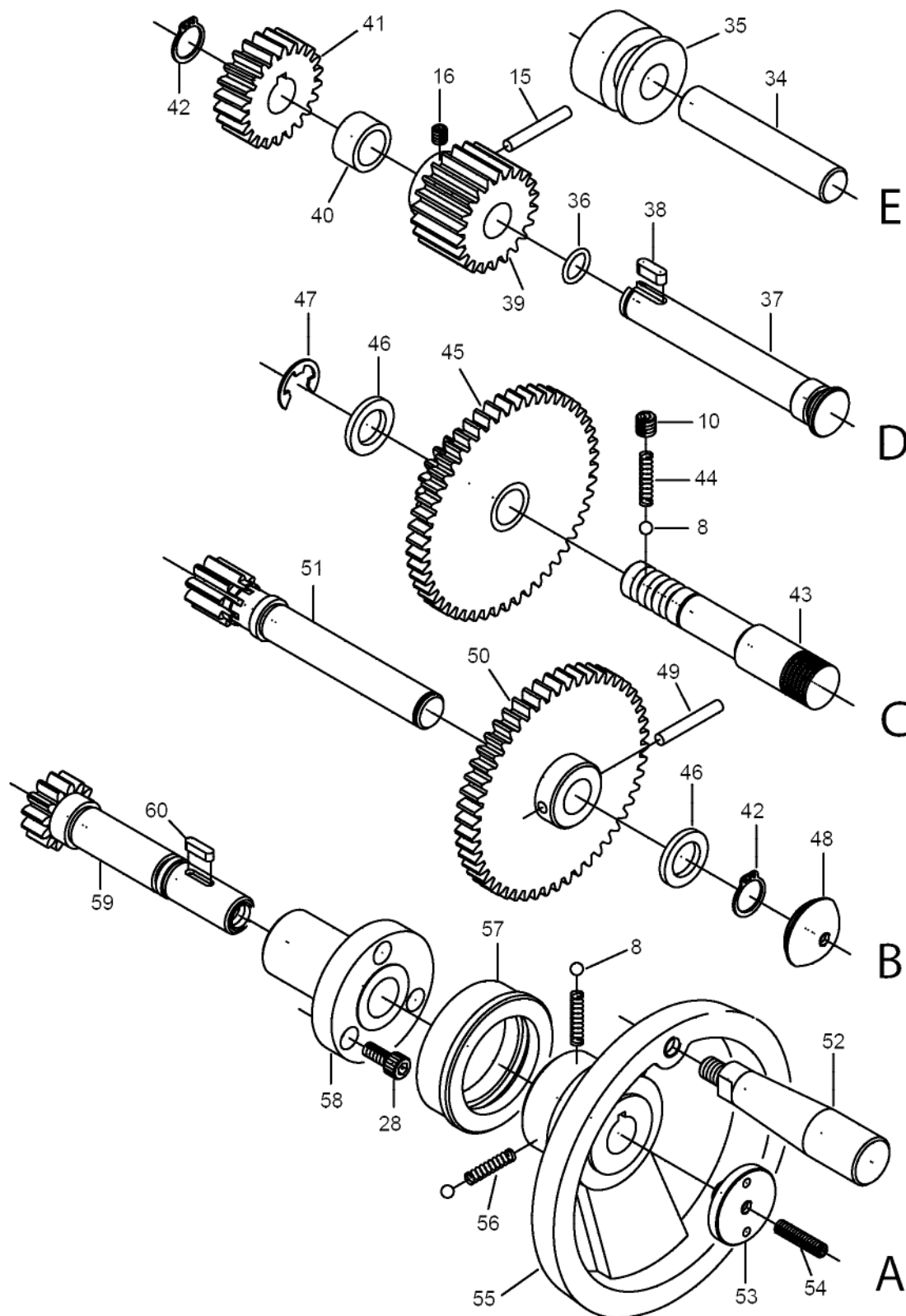

## APRON ASSEMBLY PARTS LIST

Index No.	Part No.	Description	Size	Qty.
1	E1340VS-C01	Half Nut	Ø42*40L 8TPI	1
2	TS-1503021	Socket Head Cap Screw	M6*10mm	2
3	E1340VS-C03	Bracket	105L*50W*71h	1
	E1340VS-C01A	Half Nut Assembly (Includes #1-3)		1
4	TS-1503041	Socket Head Cap Screw	M6*16mm	6
5	E1340VS-C05	Gib	13.8*110h*125L	1
6	TS-1523051	Set Screw	M6*16mm	3
7	TS-1504081	Socket Head Cap Screw	M8*40mm	2
8	SB-1/4	Ball Steel	1/4 in. dia.	4
9	E1340VS-C09	Spring	1/4 in.*50mm.	1
10	TS-1524011	Set Screw	M8*8mm	2
11	E1340VS-C11	Taper Pin	#6x50mm	2
12	E1340VS-C12	Casting	275L*95*172h	1
13	E1340VS-C13	Shaft	Ø39.9*75L	1
14	E1340VS-C14	Lever	62L*36W*17h	1
15	E1340VS-C15	Pin	5*35 mm.	2
16	TS-1523011	Set Screw	M6*6mm	2
17	E1340VS-C17	Handle	Ø50*30L Ø16	1
18	E1340VS-C18	Pin	5*50 mm.	1
19	E1340VS-C19	Handle	Ø1/2" *107L	1
20	E1340VS-C20	Handle	3/8 in.	2
	E1340VS-C20A	Handle Assy (including #19&20)		1
21	E1340VS-C21	Cover	62L*40W*23h Ø19	2
22	E1340VS-C22	Worm	Ø37*Ø19.05*60L	1
23	E1340VS-C23	Pin	3*8 mm.	2
24	E1340VS-C24	Key	5*60 mm.	1
25	E1340VS-C25	Keep Assy.	50*65*45h	1
26	E1340VS-C26	Plug	Ø28*8W	1
27	E1340VS-C27	Cam	50*30*12h	1
28	TS-1503031	Socket Head Cap Screw	M6*12mm	5
29	E1340VS-C29	Gear Shaft		1
30	E1340VS-C30	Lever		1
	E1340VS-C30A	Handle Assy (including #20&30)		1
31	TS-1503101	Socket Head Cap Screw	M6*45mm	1
32	E1340VS-C32	Oil Sight	3/4 in. (19mm.)	1
33	E1340VS-C33	Plug	3/8 G.P.	1
34	E1340VS-C34	Shaft	Ø16*85L	1
35	E1340VS-C35	Collar	Ø38*Ø16*30L	1
36	E1340VS-C36	O-Ring	11*16*2.5 mm.	1



Index No.	Part No.	Description	Size	Qty.
37	E1340VS-C37	Shaft	Ø22*117L	1
38	E1340VS-C38	Key	5*15 mm.	1
39	E1340VS-C39	Gear	2M22T	1
40	E1340VS-C40	Collar	Ø22*Ø16*12W	1
41	E1340VS-C41	Gear	Ø48*Ø16*16W	1
42	E1340VS-C42	Circlip	S-16 mm.	2
43	E1340VS-C43	Shaft	Ø20*128.76L	1
44	E1340VS-C44	Spring	1/4 in.*30mm.	1
45	E1340VS-C45	Gear	2M 20T 2M50T	1
46	E1340VS-C46	Collar	Ø25.4*Ø16*3W	2
47	E1340VS-C47	Circlip	E-12 mm.	1
48	E1340VS-C48	Plug	Ø31.5*11W	1
49	E1340VS-C49	Pin	5*30 mm.	1
50	E1340VS-C50	Gear	2M 52T	1
51	E1340VS-C51	Rack Pinion	Ø23.5*134L	1
52	E1340VS-C52	Handle	Ø22*100L	1
53	E1340VS-C53	Pulg	Ø35*15L M6	1
54	TS-1523071	Set Screw	M6*25mm	1
55	E1340VS-C55	Handwheel	Ø140*68h	1
56	E1340VS-C56	Spring	1/4 in.*20mm.	2
57	E1340VS-C57	Index Ring	Ø63*Ø45*20W	1
58	E1340VS-C58	Keep Assy.	Ø60*Ø18*57L	1
59	E1340VS-C59	Shaft	Ø31*114L 1/2~20NF	1
60	E1340VS-C60	Key	4*15 mm.	1



**CARRIAGE ASSEMBLY**

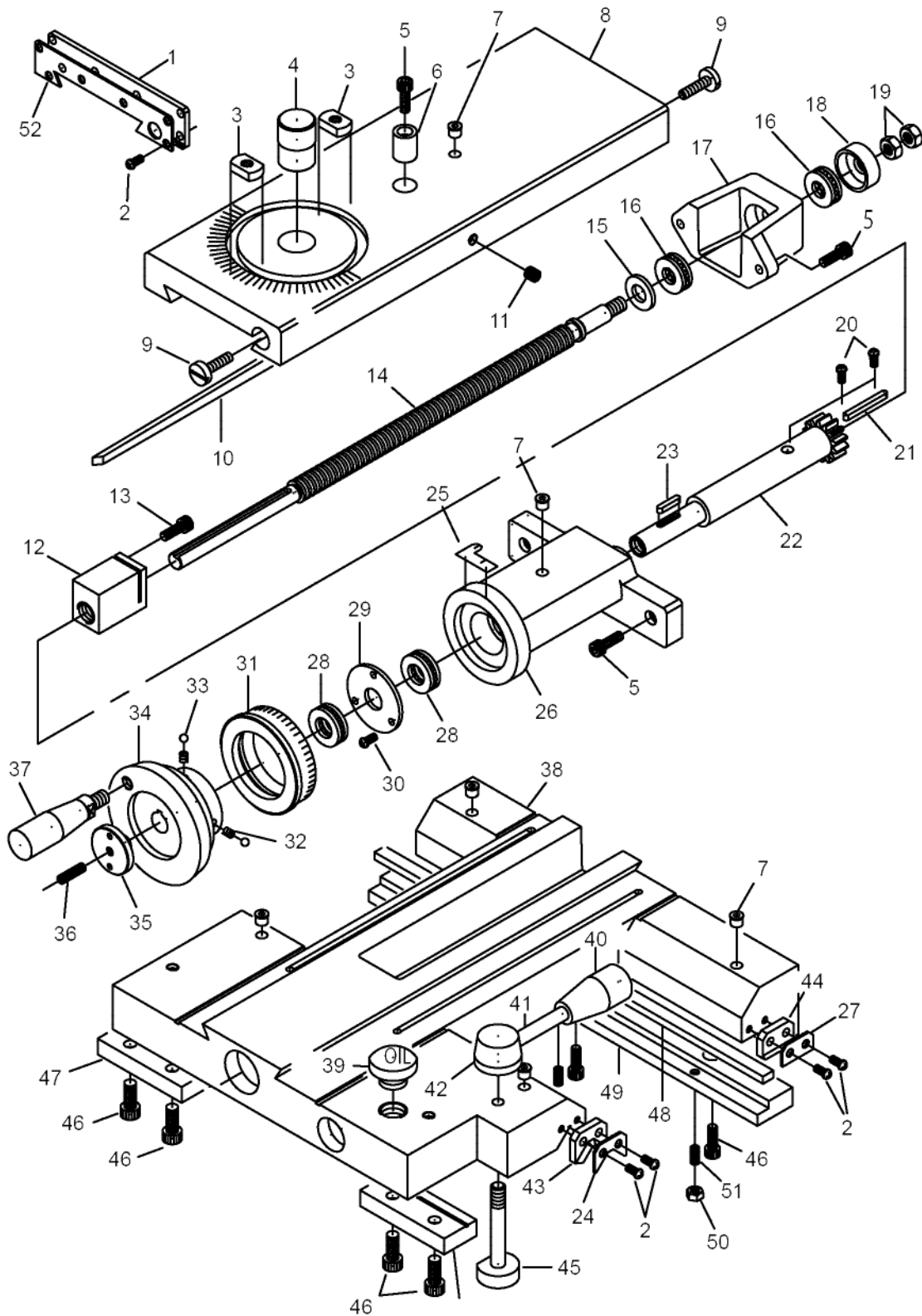



## CARRIAGE ASSEMBLY PARTS LIST

Index No.	Part No.	Description	Size	Qty.
1	E1340VS-D01	Wiper	PVC	1
2	E1340VS-D02	Screw	3/16*3/8 in.	14
3	E1340VS-D03	Nut	6.5t*Ø7/8**14W	2
4	E1340VS-D04	Pirot	Ø25.4*35L	1
5	TS-1503051	Socket Head Cap Screw	M6*20mm	4
6	E1340VS-D06	Collar	Ø16*20L Ø1/4	1
7	E1340VS-D07	Oil	5/16 in.	6
8	E1340VS-D08	Cross-Slide	405L*130W*30H	1
8	E1440VS-D08	Cross-Slide		1
9	E1340VS-D09	Gib Screw	Ø5/8**30L	2
10	E1340VS-D10	Gib	15*23*460	1
11	TS-1524011	Set Screw	M8*8mm	1
12	E1340VS-D12	Nut	45L*25W*32h	1
13	TS-1503031	Socket Head Cap Screw	M6*12mm	1
14	E1340VS-D14	Screw	Ø5/8**430L 10TPI	1
	E1340VS-D12A	Nut Assembly (Includes #12-14)		1
15	E1340VS-D15	Washer	Ø25*1/2**3t	1
16	BB-51101	Thrust	NO. 51101	2
17	E1440VS-D17	Keep Ass'y		1
17	E1340VS-D17	Keep Ass'y	260L*35W*20t	1
18	E1340VS-D18	Bearing Cover	Ø31*Ø12*11.5L	1
19	TS-0561031	Nut	3/8 in.	1
20	E1340VS-D20	Nail	2 mm.	2
21	E1340VS-D21	Key	4*40 mm.	1
22	E1440VS-D22	Gear		1
22	E1340VS-D22	Gear	Ø32*139L	1
23	E1340VS-D23	Key	4*20 mm.	1
24	E1340VS-D24	Wiper		2
25	E1340VS-D25	Index Plate		1
26	E1440VS-D26	Keep Ass'y	Ø70*73L*Ø22	1
26	E1340VS-D26	Keep Ass'y		1
27	E1340VS-D27	Wiper		2
28	BB-51102	Thrust	NO. 51102	2
29	E1340VS-D29	Washer	Ø49.5*Ø16*36	1
30	TS-081F021	Screw	1/4*3/8 in.	3
31	E1340VS-D31	Index Ring	Ø73*Ø50*19.9L	1
32	E1340VS-D32	Spring	1/4 in.*20mm.	2
33	E1340VS-D33	Steel Ball	1/4 in.	2
34	E1340VS-D34	Handwheel	Ø90*Ø15*49L	1

Index No.	Part No.	Description	Size	Qty.
35	E1340VS-D35	Pulg	Ø35*15L M6TAP	1
36	TS-1523071	Set Screw	M6*25mm	1
37	E1340VS-D37	Handle	Ø19*80L	1
38	E1340VS-D38	Saddle Casting	343L*310W*67H	1
39	E1340VS-D39	Plug	3/4 in. (P.V.C)	1
40	E1340VS-D40	Handle	3/8 in.	1
	E1340VS-D40A	Handle Assy (including #40&41)		1
41	E1340VS-D41	Handle	Ø3/8**65L	1
42	E1340VS-D42	Handle	Ø5/4**22W	1
43	E1340VS-D43	Wiper	PVC	2
44	E1340VS-D44	Wiper	PVC	1
45	E1340VS-D45	Screw	Ø9/8**75L	1
46	TS-1504041	Socket Head Cap Screw	M8*20mm	7
47	E1340VS-D47	Strip	80L*31W*13H	2
48	E1340VS-D48	Gib	10W*5T*310L	1
49	E1340VS-D49	Strip	310L33.5W*15H	1
50	TS-1540041	Nut	M6mm.	3
51	TS-1523051	Set Screw	M6*16mm	3
52	E1340VS-D52	Wiper		1

# TOOLPOST ASSEMBLY

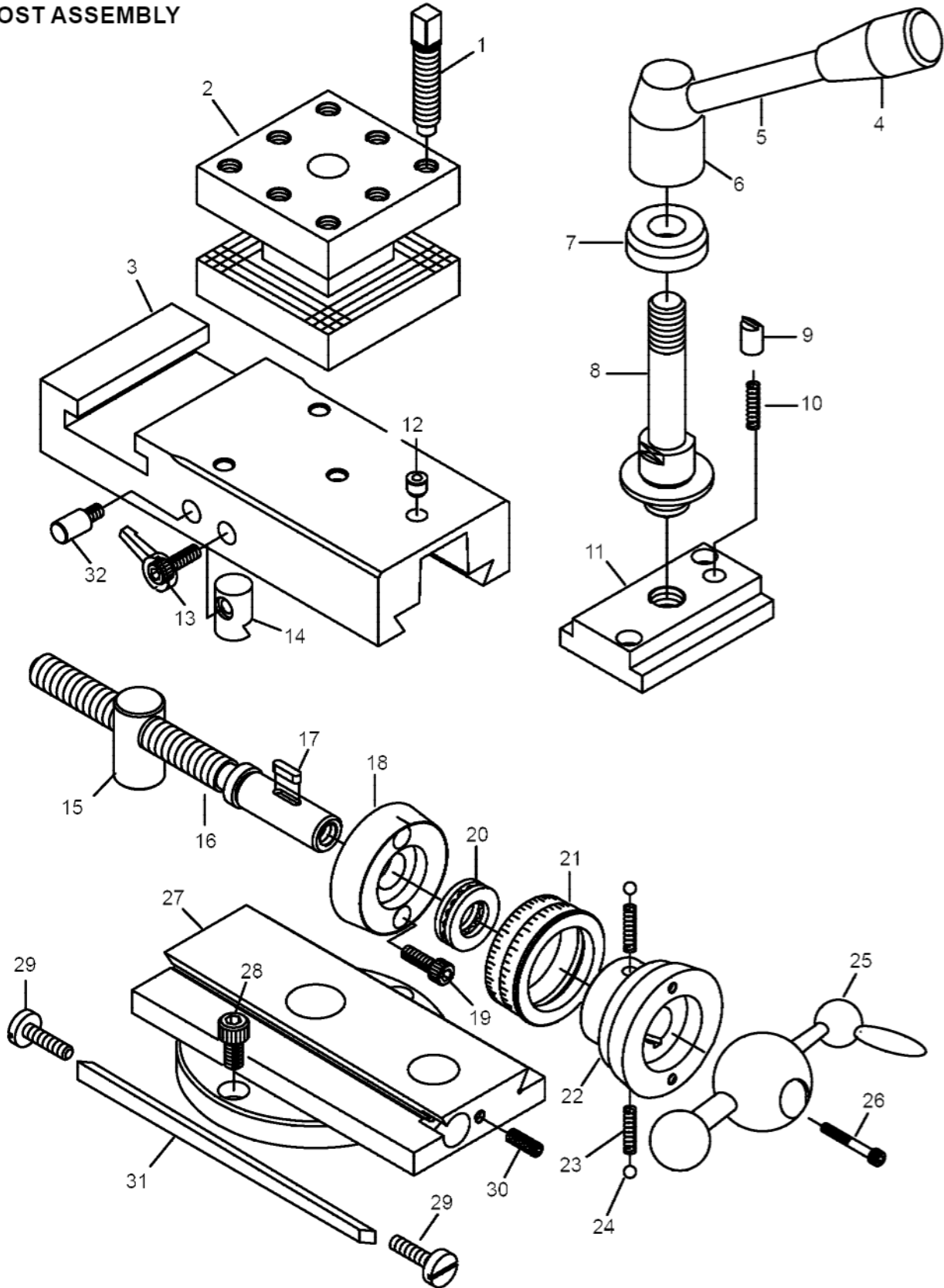

## TOOLPOST ASSEMBLY PARTS LIST

Index No.	Part No.	Description	Size	Qty.
1	E1340VS-E01	Screw	Ø12.7*65L	8
2	E1340VS-E02	Toolpost	90*90*72h	1
3	E1340VS-E03	Top Slide	215l*90W*38h	1
4	E1340VS-E04	Handle	3/8 in.	1
	E1340VS-E04A	Handle Assy (including #4&5)		1
5	E1340VS-E05	Handle	Ø1/2" *107L	1
6	E1340VS-E06	Handle	Ø32*48L 5/8"~11NCTAP	1
7	E1340VS-E07	Washer	Ø35*Ø16*12h	1
8	E1340VS-E08	Bolt	Ø10*111L	1
9	E1340VS-E09	Pad	Ø3/5"*15L	1
10	E1340VS-E10	Spring	3/8in *20mm.	1
11	E1340VS-E11	Nut	Ø90*50W*18h	1
12	E1340VS-E12	Oil	5/16 in.	1
13	E1340VS-E13	Handle		1
14	E1340VS-E14	Pad	Ø16*24L	1
15	E1340VS-E15	Nut	Ø20*40L	1
16	E1340VS-E16	Screw	Ø3/4"*177L 2TPI	1
	E1340VS-E15A	Nut Assembly (Includes #15-16)		1
17	E1340VS-E17	Key	8*15 mm.	1
18	E1340VS-E18	Keep Ass'y	Ø57*Ø17*16W	1
19	TS-1503041	Socket Head Cap Screw	M6*16mm	2
20	BB-51103	Thrust	NO. 51103	1
21	E1340VS-E21	Index Ring	Ø54*Ø40*20	1
22	E1340VS-E22	Handwheel	Ø62*Ø17*42L	1
23	E1340VS-E23	Spring	1/4 in.*20mm.	2
24	E1340VS-E24	Ball Steel	1/4 in. dia.	2
25	E1340VS-E25	Three Ball Handle		1
26	TS-1503071	Socket Head Cap Screw	M6*30mm	1
27	E1340VS-E27	Swiver Slide	35H	1
27	E1440VS-E27	Swiver Slide	44H	1
28	TS-1504031	Socket Head Cap Screw	M8*16mm	2
29	E1340VS-E29	Gib Screw	Ø5/8"*30L	2
30	TS-1523051	Set Screw	M6*16mm	1
31	E1340VS-E31	Gib	112*20*225	1
32	E1340VS-E32	Pin		1

# TAILSTOCK ASSEMBLY

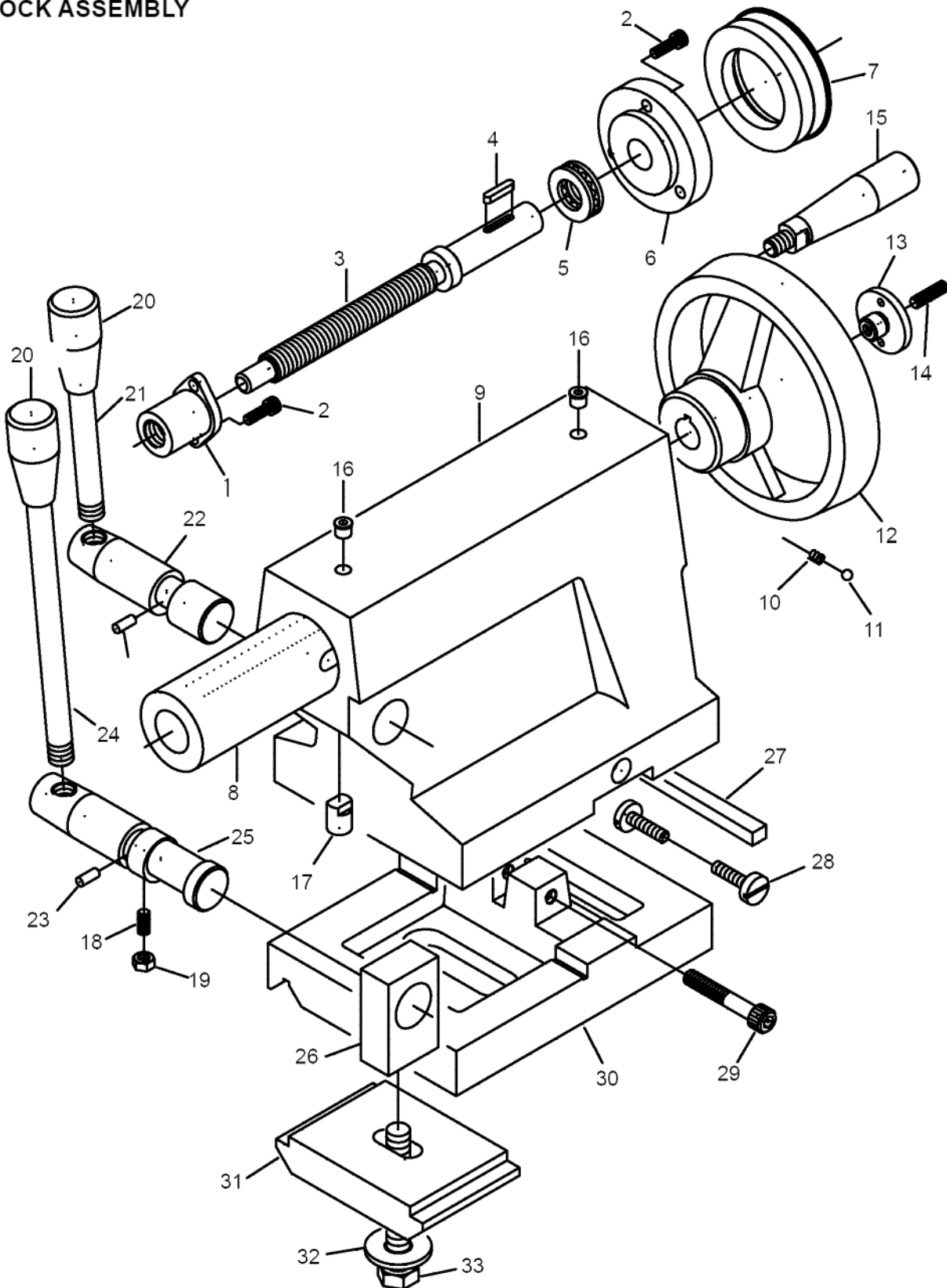



## TAILSTOCK ASSEMBLY PARTS LIST

Index No.	Part No.	Description	Size	Qty.
1	E1340VS-F01	Nut	43L*30W*33h	1
2	TS-1503041	Socket Head Cap Screw	M6*16mm	5
3	E1340VS-F03	Screw	Ø22*208L 10TPI	1
	E1340VS-F01A	Nut Assembly (Includes #1-3)		1
4	E1340VS-F04	Key	4*20 mm.	1
5	BB-51103	Thrust	NO. 51103	1
6	E1340VS-F06	Keep	Ø70*Ø17*17W Ø32*9	1
7	E1340VS-F07	Index Ring	Ø73*Ø45*20W	1
8	E1340VS-F08	Barrel	Ø45*210L Ø20	1
9	E1340VS-F09	Casting	230L*136W*174.5h	1
10	E1340VS-F10	Spring	1/4 in.*20mm.	2
11	E1340VS-F11	Ball Steel	1/4 in. dia.	2
12	E1340VS-F12	Handle	Ø22*100L	2
13	E1340VS-F13	Pulg	Ø35*15L M6TAP	4
14	TS-1523071	Set Screw	M6*25mm	1
15	E1340VS-F15	Handle	Ø140*68h.	1
16	E1340VS-F16	Oil	5/16 in.	2
17	E1340VS-F17	Pad	Ø1/2"*16.7L	1
18	TS-1523051	Set Screw	M6*16mm	2
19	TS-1540041	Nut	M6	2
20	E1340VS-F20	Handle	3/8 in.	1
21	E1340VS-F21	Handle	Ø1/2" *107L	3
	E1340VS-F21A	Handle Assy (including #20&21)		1
22	E1340VS-F22	Shaft	Ø25*97L	1
23	E1340VS-F23	Pin	5*12 mm.	2
24	E1340VS-F24	Handle	Ø1/2"*190L	1
	E1340VS-F24A	Handle Assy (including #20&24)		1
25	E1340VS-F25	Shaft	Ø25*120L	1
26	E1340VS-F26	Pirot Block	36L*20W*57h	1
27	E1340VS-F27	Gib	8*10*136	1
28	E1340VS-F28	Gib Screw	Ø5/8"*30L	2
29	TS-1504101	Socket Head Cap Screw	M8*50mm	2
30	E1340VS-F30	Base	185L*136W*53h	1
30	E1440VS-F30	Base	185L*136W*66h	1
31	E1340VS-F31	Clamp Plate	106L*70W*22h	1
32	TS-0680061	Washer	1/2 in.	1
33	E1340VS-F33	Cap Screw	1/2*2-5/8 in.	1

# BED ASSEMBLY

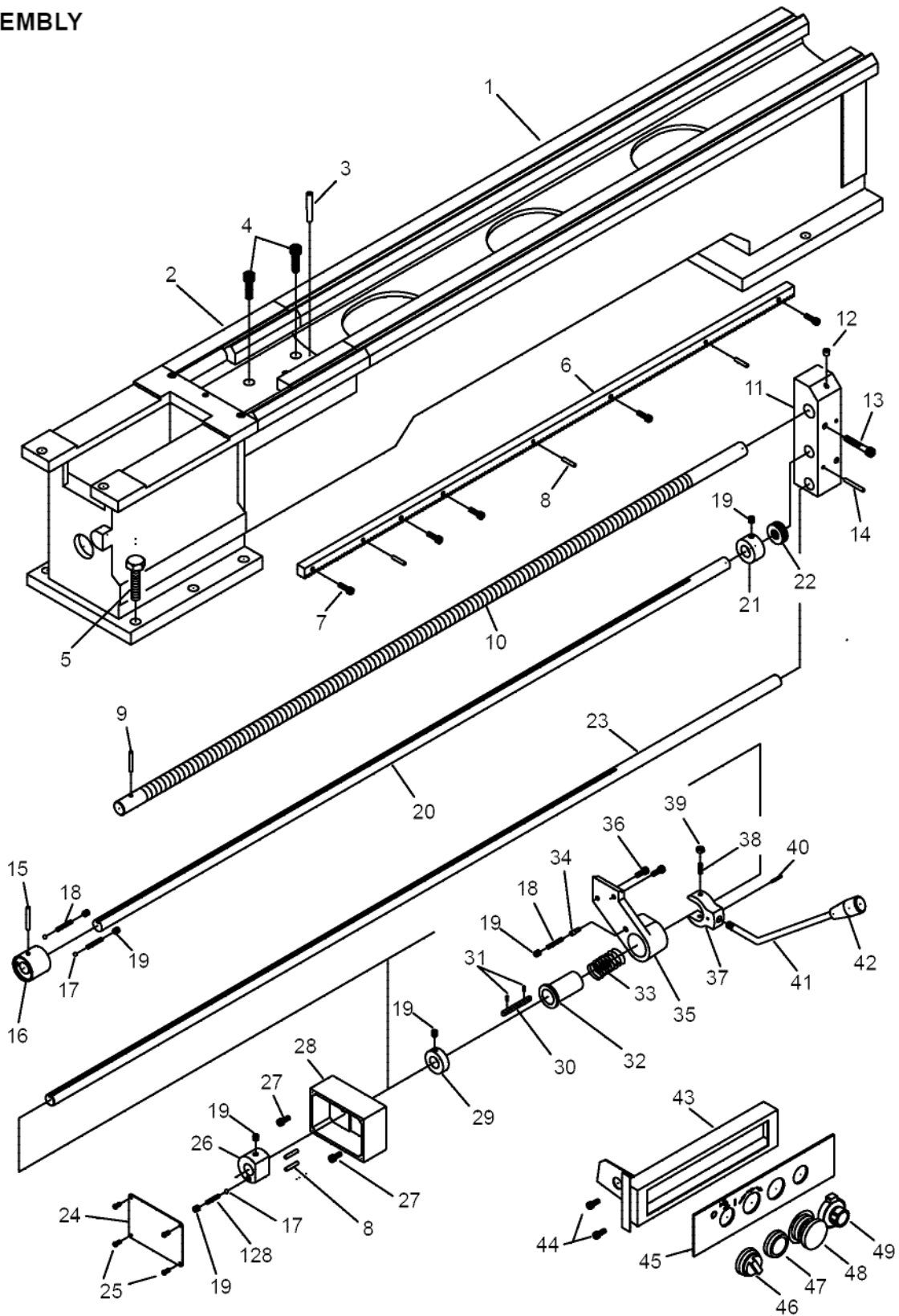

## BED ASSEMBLY PARTS LIST

Index No.	Part No.	Description	Size	Qty.
1	E1340VS-G01	Bed	206W*280.5h*1420L	1
2	E1340VS-G02	Gap Piece	206W*240L*90.5h	1
3	E1340VS-G03	Taper Pin	#6x50mm	2
4	TS-1505051	Socket Head Cap Screw	M10*35mm	4
5	TS-0070041	Cap Screw	1/2*1-3/4 in.	6
6	E1340VS-G06	Rack	16*19 1050L	1
7	TS-1503051	Socket Head Cap Screw	M6*20mm	8
8	E1340VS-G08	Pin	5*25 mm.	5
9	E1340VS-G09	Pin	5*35 mm.	3
10	E1340VS-G10	Leadscrew	Ø7/8" 1338L 8TPI	1
11	E1340VS-G11	Bracket	50*50*195L	1
12	E1340VS-G12	Oil	5/16 in.	1
13	TS-1504101	Socket Head Cap Screw	M8*50mm	2
14	E1340VS-G14	Pin	5*60 mm.	2
15	E1340VS-G15	Pin	5*40 mm.	1
16	E1340VS-G16	Clutch	Ø42*Ø19*38.4L	1
17	E1340VS-G17	Ball Steel	1/4 in. dia.	3
18	E1340VS-G18	Spring	1/4 in.*35mm.	3
19	TS-1524011	Set Screw	M8*8mm	7
20	E1340VS-G20	Feed Shaft	Ø3/4" 1350L	1
21	E1340VS-G21	Bearing Cover	Ø39*Ø19.05*21W	1
22	BB-51104	Thrust	NO. 51104	1
23	E1340VS-G23	Third-Rod Shaft	Ø3/4" 1710L	1
24	E1340VS-G24	Perspex Cover	114L*80W*1.0t	1
25	E1340VS-G25	Screw	1/4*3/8 in.	28
26	E1340VS-G26	Collar	Ø44*Ø19.05*30W	1
27	TS-1503031	Socket Head Cap Screw	M6*12mm	3
28	E1340VS-G28	Box	115L*80W*48h	1
29	E1340VS-G29	Collar	Ø38*Ø19.05*12W	1
30	E1340VS-G30	Key	5*60 mm.	1
31	E1340VS-G31	Pin	3*8 mm.	2
32	E1340VS-G32	Sleeve	Ø38*Ø19.05*60L	1
33	E1340VS-G33	Spring	5/8in *21mm.	1
34	E1340VS-G34	Pin	Ø6.3*19L	1
35	E1340VS-G35	Bracket		1
36	TS-1503041	Socket Head Cap Screw	M6*16mm	4
37	E1340VS-G37	Fork	Ø51*20	1
38	TS-1523051	Set Screw	M6*16mm	1



Index No.	Part No.	Description	Size	Qty.
39	TS-1540041	Nut	M6	1
40	E1340VS-G40	Pin	3*20 mm.	1
41	E1340VS-G41	Handle	Ø3/8"*220L	1
	E1340VS-G41A	Handle Assy (including #41&42)		1
42	E1340VS-G42	Handle	3/8 in.	1
43	E1340VS-G43	Box		1
44	E1340VS-G44	Screw	3/16*3/8 in.	2
45	E1340VS-G45	Electric Plate		1
46	E1340VS-G46	Coolant Selecting Switch		1
47	E1340VS-G47	Jogging Push Bottom Switch		1
48	E1340VS-G48	Emergency Stop Switch		1
49	E1340VS-G49	Variable Speed Selector		1
128	E1340VS-G128	Spring	1/4 in.*30mm.	1

**CABINET AND PANEL ASSEMBLY**

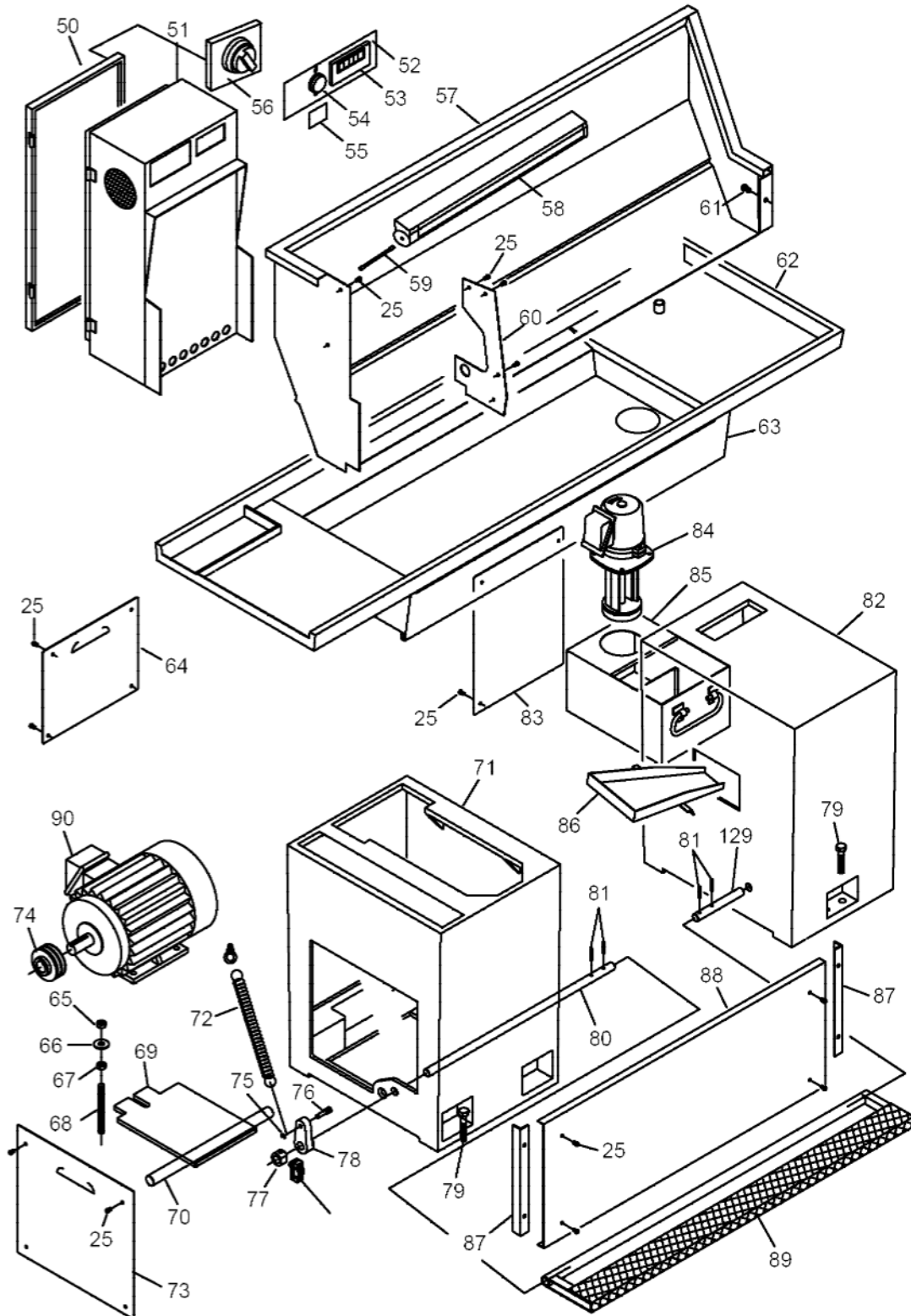





## CABINET AND PANEL ASSEMBLY PARTS LIST

Index No.	Part No.	Description	Size	Qty.
50	E1340VS-G50	Electric Box Door		1
51	E1340VS-G51	Electric Box		1
52	E1340VS-G52	Electric Plate		1
53	E1340VS-G53	RPM Speed Meter		1
54	E1340VS-G54	Pilot Light		1
55	E1340VS-G55	Warning Plate		1
56	E1340VS-G56	Power Switch		1
57	E1340VS-G57	Splash Guard		1
58	E1340VS-G58	Work Lamp	AC24V 9W 0.5m/500Lux	1
59	E1340VS-G59	Pipe	115mm	1
60	E1340VS-G60	Guard		1
61	TS-0207041	Cap Screw	1/4*3/4in.	1
62	E1340VS-G62	Tray		1
63	E1340VS-G63	Chip Tray		1
64	E1340VS-G64	Cover		1
65	TS-0561031	Nut	3/8 in.	3
66	TS-0680061	Washer	1/2 in.	1
67	TS-0561051	Nut	1/2 in.	3
68	E1340VS-G68	Screw		1
69	E1340VS-G69	Platform		1
70	E1340VS-G70	Shaft		1
71	E1340VS-G71	Stand		1
72	E1340VS-G72	Spring		1
73	E1340VS-G73	Cover		1
74	E1340VS-G74	Pulley		1
75	E1340VS-G75	Circlip	E-6 mm.	1
76	E1340VS-G76	Fulcrum		1
77	E1340VS-G77	Collar		1
78	E1340VS-G78	Lever		1
79	TS-0100041	Cap Screw	1/2*1-1/4 in.	6
80	E1340VS-G80	Shaft		1
81	E1340VS-G81	Pin	5*30 mm.	4
82	E1340VS-G82	Stand		1
83	E1340VS-G83	Cover		1
84	E1340VS-G84	Pump		1
85	E1340VS-G85	Tank		1
86	E1340VS-G86	Tray		1
87	E1340VS-G87	Bracket		2
88	E1340VS-G88	Front Plate		1
89	E1340VS-G89	Pedal		1
90	E1340VS-G90	Main Motor	3HP 60HZ 220/440V	1
129	E1340VS-G129	Shaft		1

**END GEAR ASSEMBLY**

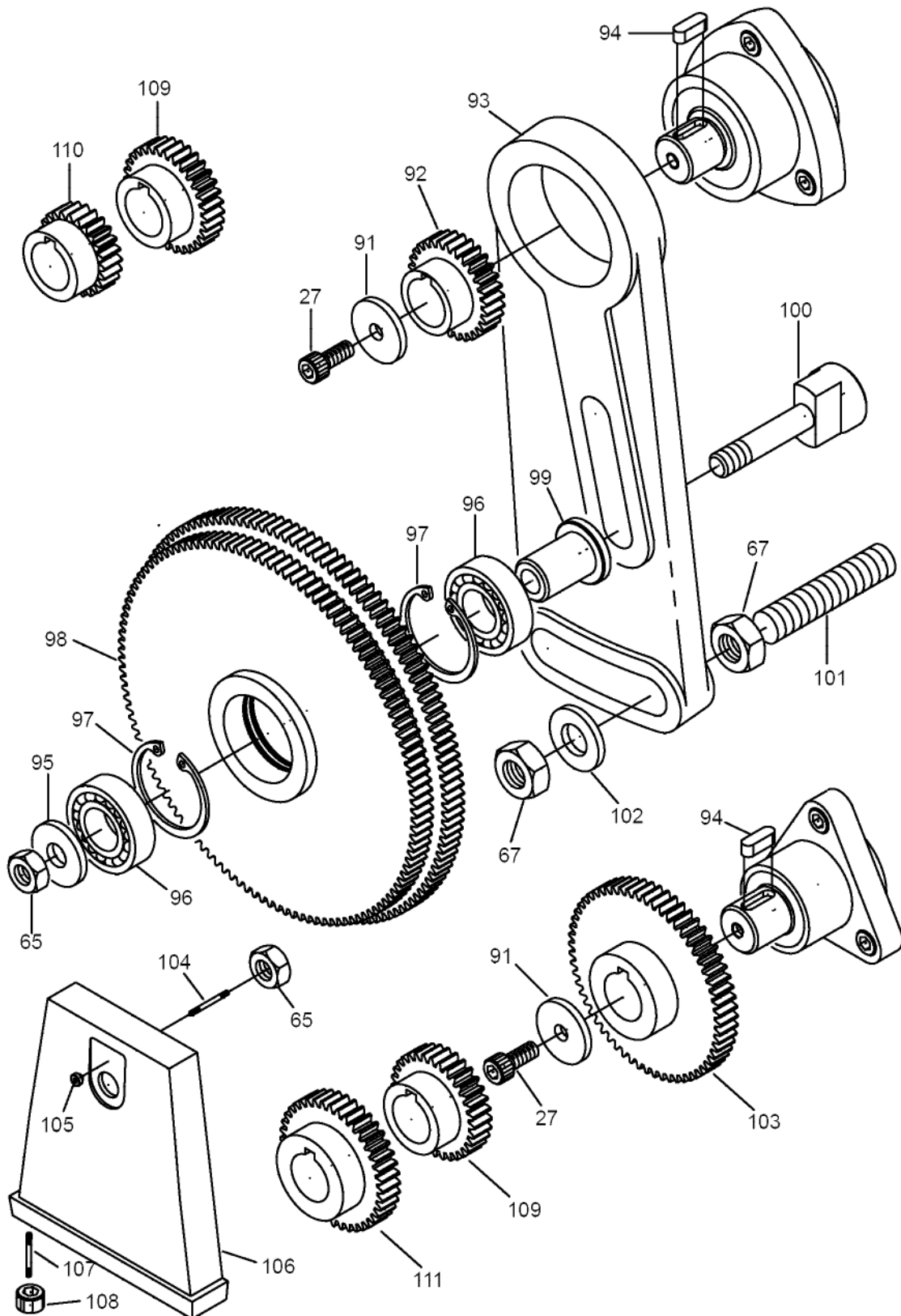



## END GEAR ASSEMBLY PARTS LIST

Index No.	Part No.	Description	Size	Qty.
27	TS-1503031	Socket Head Cap Screw	M6*12mm	2
65	TS-0561031	Nut	3/8 in.	2
67	TS-0561051	Nut	1/2 in.	2
91	E1340VS-G91	Washer	Ø25*Ø1/4"*3t	2
92	E1340VS-G92	Gear	1.25M 30T	1
93	E1340VS-G93	Swing Frame		1
94	E1340VS-G94	Key	5*15 mm.	2
95	E1340VS-G95	Washer	Ø25*Ø3/5"*5t	1
96	BB-6003Z	Bearing	NO. 6003Z	2
97	E1340VS-G97	Circlip	R-35 mm.	2
98	E1340VS-G98	Gear	1.25M 120T/127T	1
99	E1340VS-G99	Shaft Collar	Ø25*Ø3/8"*29L	1
100	E1340VS-G100	Shaft	Ø25*65L	1
101	E1340VS-G101	Shaft		1
102	E1340VS-G102	Washer	Ø25*1/2"*3t	1
103	E1340VS-G103	Gear	1.25M 60T	1
104	E1340VS-G104	Stud	Ø3/8"*105L	1
105	E1340VS-G105	Nut	Ø*16W 3/8~16NC	1
106	E1340VS-G106	End Cover		1
106	E1440VS-G106	End Cover		1
107	E1340VS-G107	Cap Screw	1/4*1-1/4 in.	1
108	E1340VS-G108	Nut	1/4 in.	1
109	E1340VS-G109	Gear	1.25M 50T	2
110	E1340VS-G110	Gear	1.25M 45T	1
111	E1340VS-G111	Gear	1.25M 40T	2

**CHUCK SAFETY GUARD ASSEMBLY**

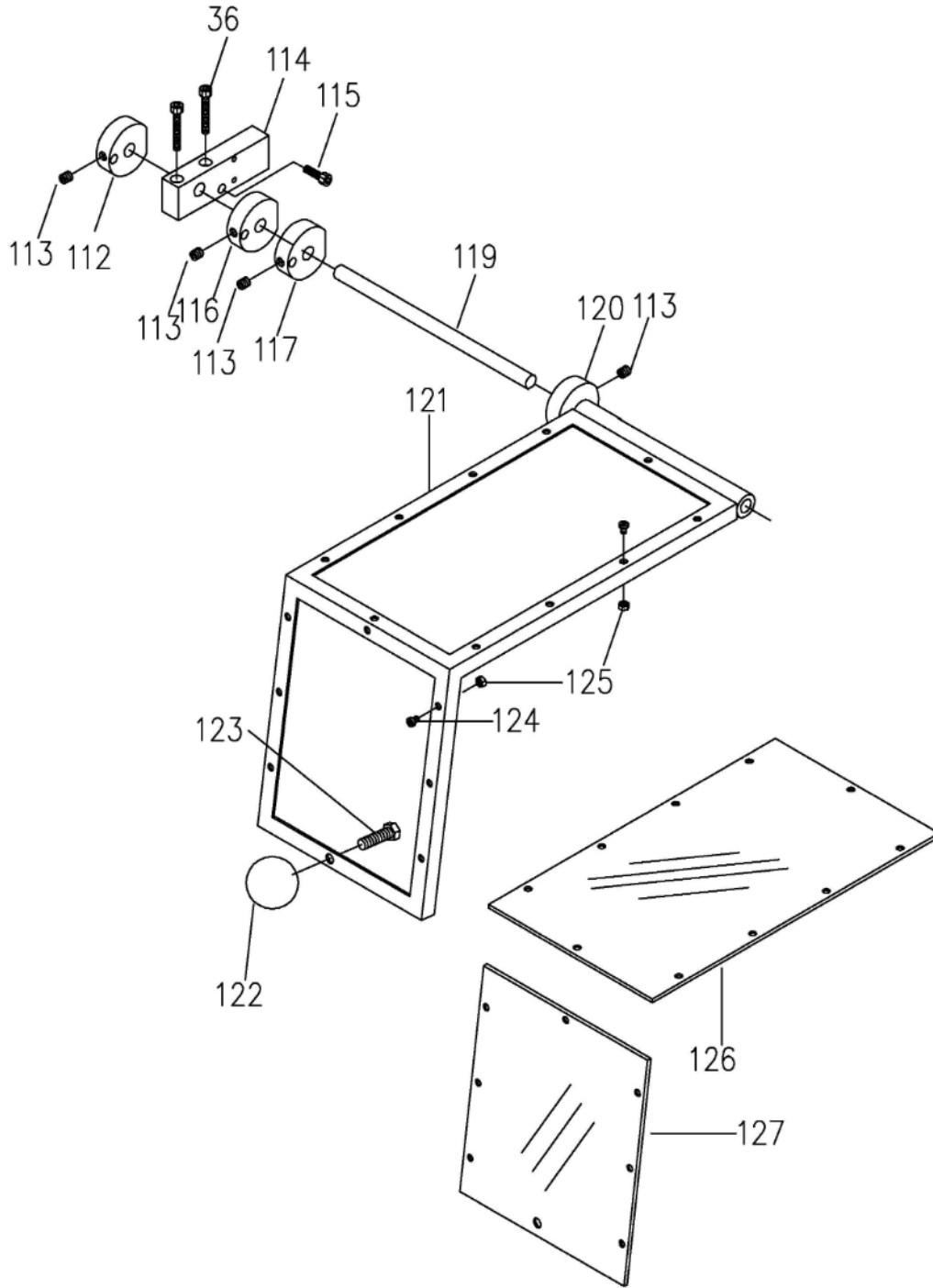



## CHUCK SAFETY GUARD ASSEMBLY PARTS LIST

Index No.	Part No.	Description	Size	Qty.
36	TS-1503041	Socket Head Cap Screw	M6*16mm	2
112	E1340VS-G112	Cam		1
113	TS-1523021	Set Screw	M6*8mm	3
114	E1340VS-G114	Keep Ass'y		1
115	TS-1503021	Socket Head Cap Screw	M6×10mm	1
116	E1340VS-G116	Collar		1
117	E1340VS-G117	Cam		1
119	E1340VS-G119	Shaft		1
120	E1340VS-G120	Collar		1
121	E1340VS-G121	Chuck Guard		1
	E1340VS-CSGA	Chuck Safety Guard ass'y w/ limit switch	(option)	1
122	E1340VS-G122	Handle	PVC	1
123	TS-1505031	Socket Head Cap Screw	M10×25mm	1
124	E1340VS-G124	Screw	3/16×1/4 in	18
125	E1340VS-G125	Nut	3/16 in	18
126	E1340VS-G126	Window	3Tx193x343mm	1
127	E1340VS-G127	Window	3Tx193x230mm	1



**COOLANT PUMP ASSEMBLY**

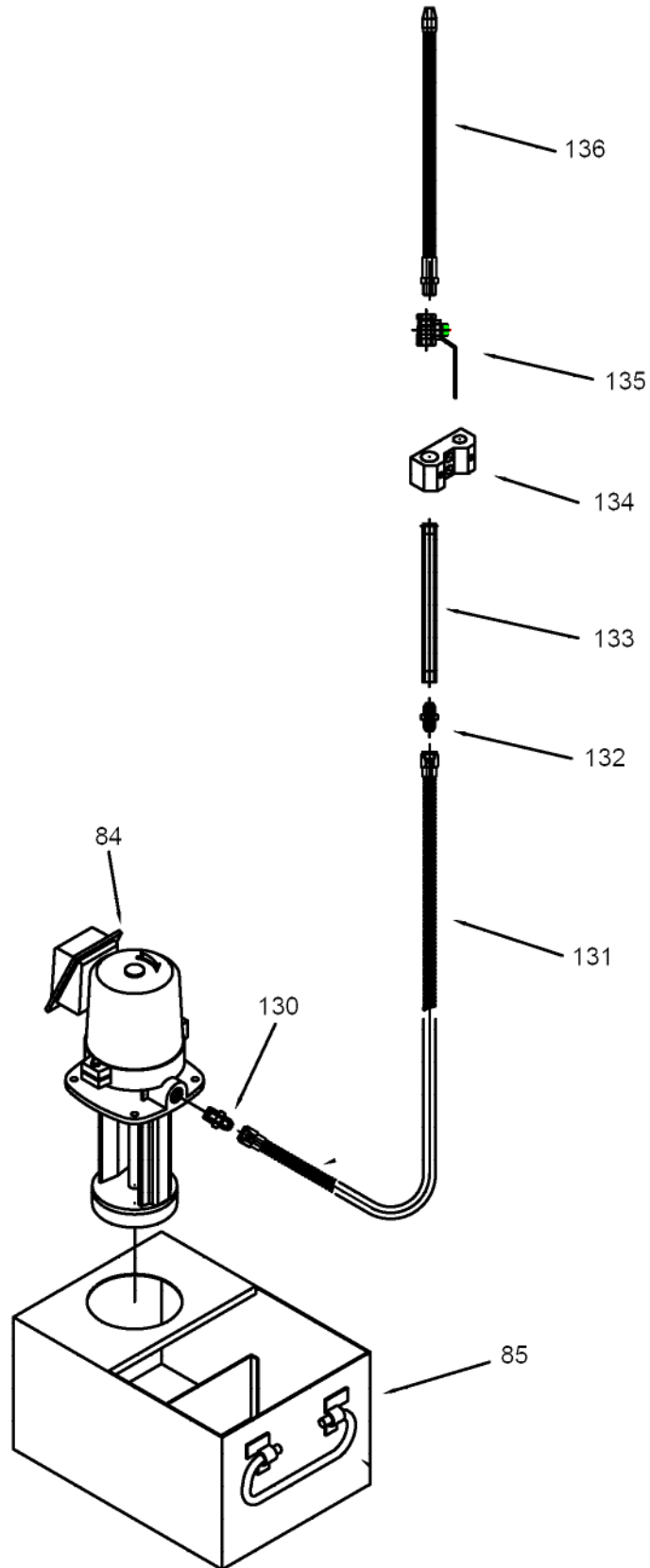



## COOLANT PUMP ASSEMBLY PARTS LIST

Index No.	Part No.	Description	Size	Qty.
84	E1340VS-G84	Pump		1
130	E1340VS-G130	Nipple		1
131	E1340VS-G131	Flexible Hose		1
132	E1340VS-G132	Nipple		1
133	E1340VS-G133	Tube		1
134	E1340VS-G134	Bracket		1
135	E1340VS-G135	Value Gate		1
136	E1340VS-G136	Spraying Pipe		1

## DIAL INDICATOR ASSEMBLY

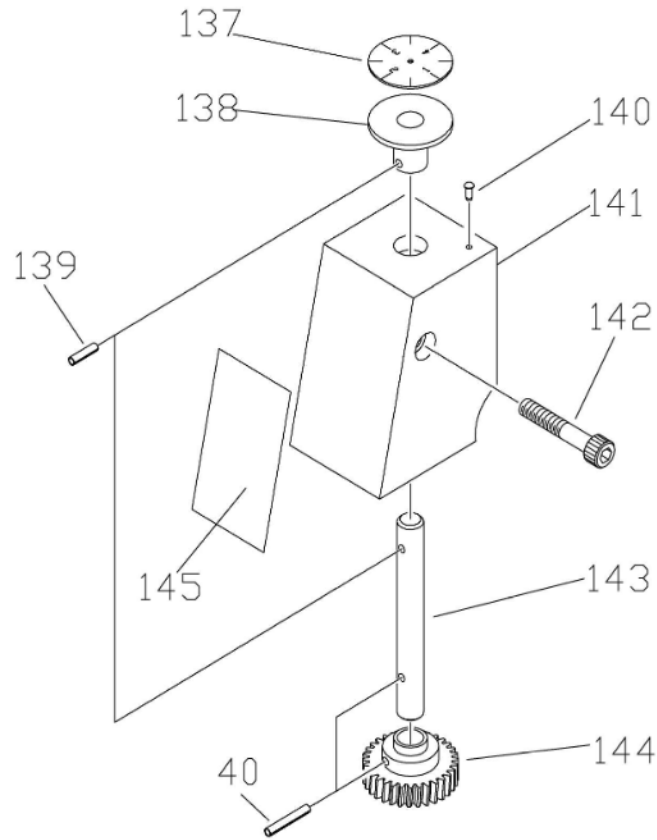

## DIAL INDICATOR ASSEMBLY PARTS LIST

Index No.	Part No.	Description	Size	Qty.
40	E1340VS-G40	Pin	3*20 mm.	1
137	E1340VS-G137	Plate		1
138	E1340VS-G138	Dog	Ø60*Ø19.05*15W	1
139	E1340VS-G139	Pin	3*12 mm.	1
140	E1340VS-G140	Nail	2 mm.	1
141	E1340VS-G141	Guard	75*59*45	1
142	TS-1503111	Socket Head Cap Screw	M6*50mm	1
143	E1340VS-G143	Shaft	Ø9.5*81L	1
144	E1340VS-G144	Gear	Ø34Ø9.5*17L	1
145	E1340VS-TP	Threading Plate		1

### CHUCK ASSEMBLY & PARTS LIST

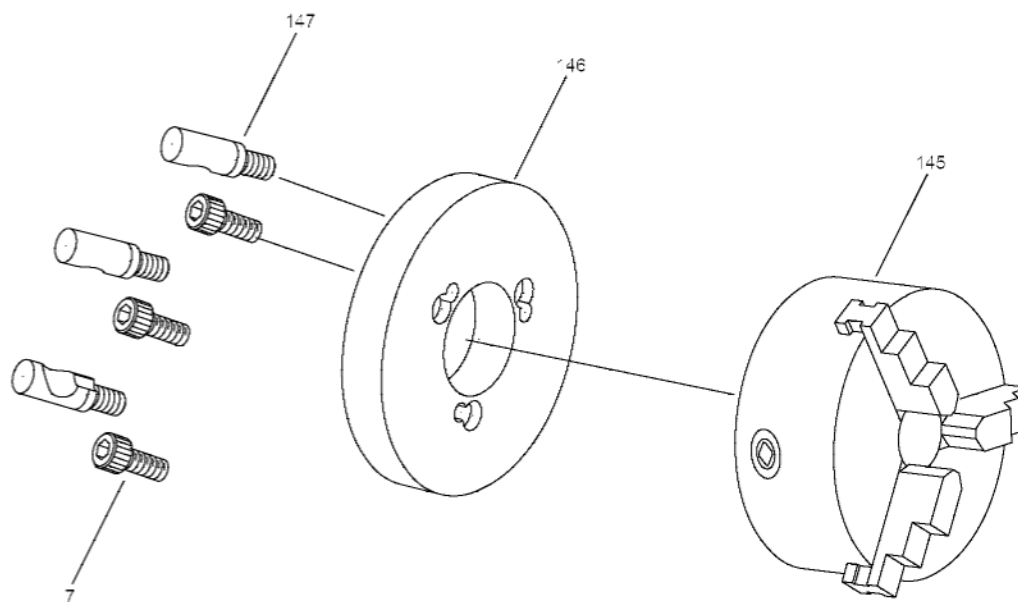

Index No.	Part No.	Description	Size	Qty.
7	TS-1503051	Socket Head Cap Screw	M6*20mm	3
145	E1340VS-SK6	Chuck	6"	1
146	E1340VS-G146	Backplate	6"	1
147	E1340VS-G147	Stud	D1-4	3

### CHUCK KEY BRACKET ASSEMBLY & PARTS LIST

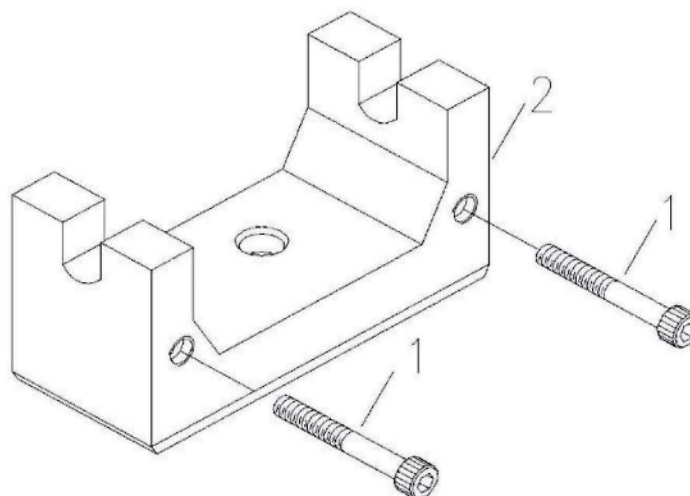

Index No.	Parts No.	Description	Size	Qty.
1	TS-1504111	Socket Head Cap Screw	M8x55mm	2
2	EVS1440B-CKB	Chuck Key Bracket		1

**FACE PLATE & PARTS LIST**

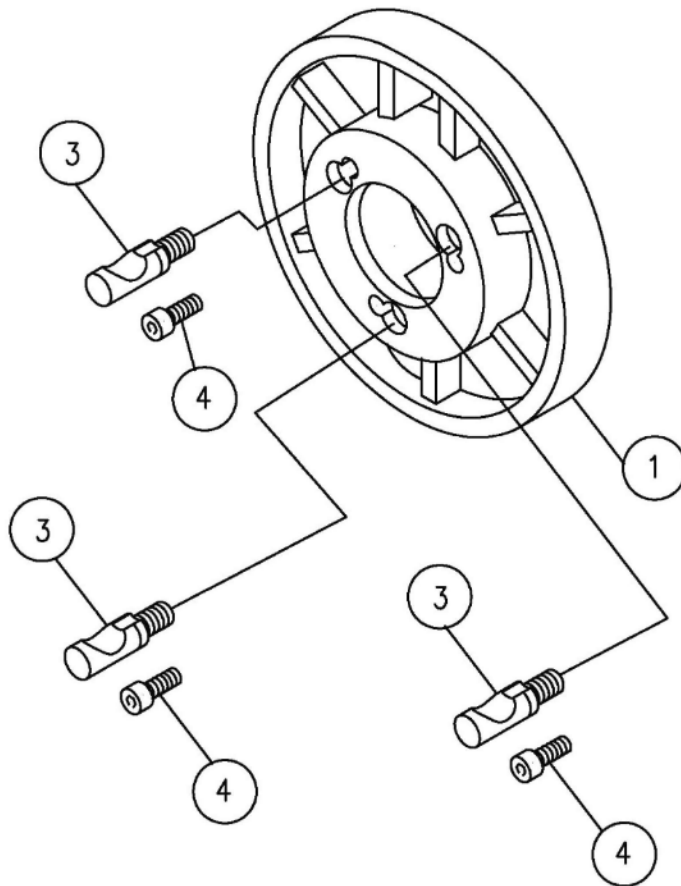

Index No.	Parts No.	Description	Size	Qty.
1	E1440VS-FP02	Face Plate 12"	Ø300x40H	1
3	EBL1236VS-G137	Stud	D1-4	3
4	TS-1503051	Socket Head Cap Screw	M6×20mm	3



### CONTROL PLATE ASSEMBLY

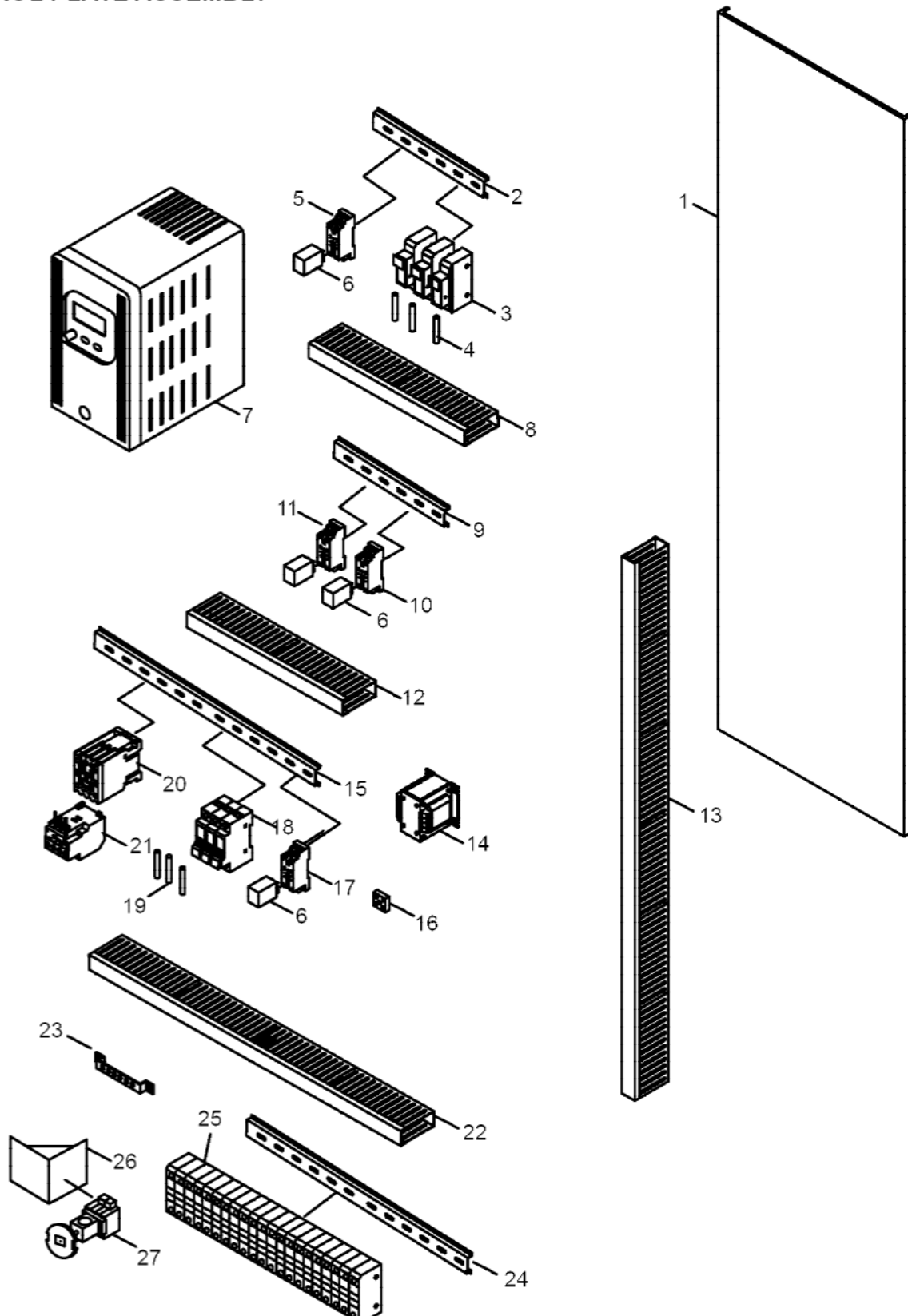

## CONTROL PLATE ASSEMBLY PARTS LIST

Index No.	Part No.	Description	Size	Qty.
1	E1340VS-H01	Plate		1
2	E1340VS-H02	Track		1
3	E1340VS-H03	Fuse Box		4
4	E1340VS-H04	Fuse	5A	4
5	E1340VS-H05	Relay Socket	for Magnetic brake	1
6	E1340VS-H06	Relay	MY4N-J Ac24v	4
7	E1340VS-H07	Inverter	VFD-B Ac240v 5HP	1
8	E1340VS-H08	Trunking		1
9	E1340VS-H09	Track		1
10	E1340VS-H10	Relay Socket		1
11	E1340VS-H11	Relay Socket		1
12	E1340VS-H12	Trunking		1
13	E1340VS-H13	Trunking		1
14	E1340VS-H14	Control Circuit Transformer	120VC Ac24v(5A)	1
15	E1340VS-H15	Track		1
16	E1340VS-H16	Bridge Rectifier		1
17	E1340VS-H17	Relay Socket		1
18	E1340VS-H18	Fuse Boxes		1
19	E1340VS-H19	Fuse	30A	3
20	E1340VS-H20	Magnetic Contactor	CU-11 Ac24v (3A1b)	1
21	E1340VS-H21	Thermal Overload Relay	RHU-10K1 0.45~0.63A	1
22	E1340VS-H22	Trunking		1
23	E1340VS-H23	Earthing Terminal Blocks		1
24	E1340VS-H24	Track		1
25	E1340VS-H25	Terminal Blocks		1
26	E1340VS-H26	Base		1
27	E1340VS-H27	Main Power Switch	690VAC 25A	1

# TAPER ATTACHMENT ASSEMBLY (OPTIONAL)

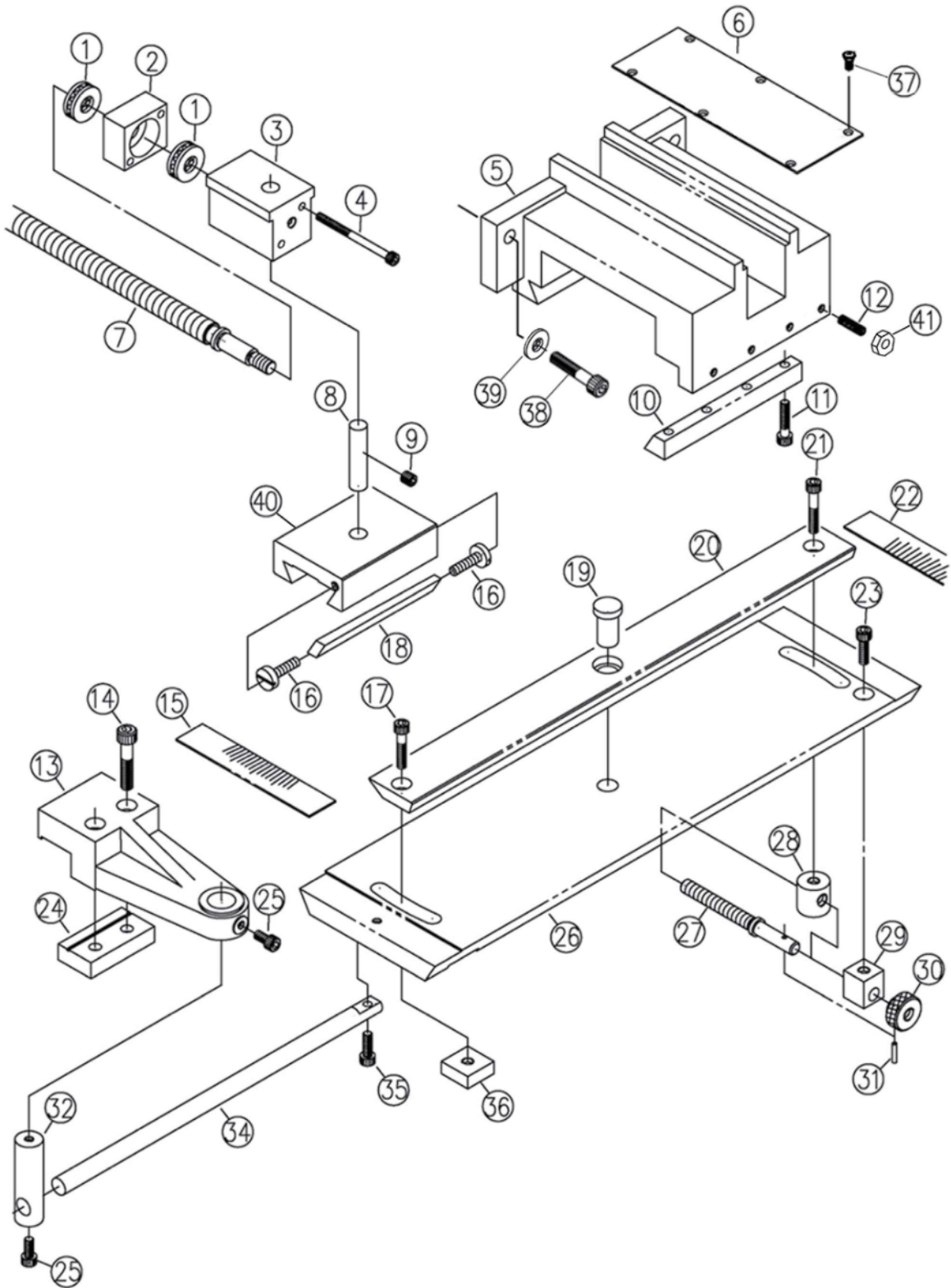

## TAPER ATTACHMENT ASSEMBLY (OPTIONAL) PARTS LIST

Index No.	Part No.	Description	Size	Qty.
1	BB-51101	Thrust Bearing	51101	2
2	E1440VS-J02	Feed Block	52x20x35	1
3	E1440VS-J03	Yoke	60x42x41.5	1
4	E1440VS-J04	Socket Head Cap Screw	M5x65MM	2
5	E1440VS-J05	Base	175x180x85	1
6	E1440VS-J06	Cover	170x63x1.2	1
7	E1440VS-J07	Lead Screw	Ø5/8"x405L	1
8	E1440VS-J08	Shaft	Ø12x50L	1
9	TS-1524011	Set Screw	M8x8mm	1
10	E1440VS-J10	Gib	130x18.86(10.2)x15	1
11	TS-1503061	Socket Head Cap Screw	M6x25mm	4
12	TS-1523061	Set Screw	M6x20mm	4
13	E1440VS-J13	Bracket	159x60x40	1
14	TS-1504081	Socket Head Cap Screw	M8x40mm	1
15	E1440VS-J15	Angle Plate	128x25x1.2	1
16	E1440VS-J16	Gib Screw		2
17	TS-1503071	Socket Head Cap Screw	M6x30mm	1
18	E1440VS-J18	Gib	110x7.27x5.57	1
19	E1440VS-J19	Pivot Pin		1
20	E1440VS-J20	Slide Bar (with riveted scales)	420x40x15	1
21	TS-1503081	Socket Head Cap Screw	M6x35mm	1
22	E1440VS-J22	Angle Plate	126x25x1.2	1
23	TS-2236181	Socket Head Cap Screw	M6x18mm	1
24	E1440VS-J24	Strip	80x31x13	1
25	TS-1503031	Socket Head Cap Screw	M6x12mm	2
26	E1440VS-J26	Base	460x130x18	1
27	E1440VS-J27	Screw	Ø3/8"(Ø9.525)x105L	1
28	E1440VS-J28	Nut	Ø22x22L	1
29	E1440VS-J29	Screw Block	19x19x22	1
30	E1440VS-J30	Knurled Nut	Ø28(Ø20)x19L	1
31	E1440VS-J31	Pin	3x15mm	1
32	E1440VS-J32	Pivot	Ø3/4"x65L	1
34	E1440VS-J33	Rod	Ø1/2"x300L	1
35	TS-1503041	Socket Head Cap Screw	M6x16mm	1
36	E1440VS-J35	Block	25x25x10	1
37	TAK1340A-5	Flat Head Screw	M5x8	6
38	TS-1504061	Hex Socket Cap Screw	M8x30	2
39	TS-1550061	Flat Washer	M8	2
40	E1440VS-J39	Slide Block		1
41	TS-1540041	Hex Nut	M6	1
	892035	Taper Assembly (#1 thru 41)		1

# COLLET CLOSER ASSEMBLY (OPTIONAL)

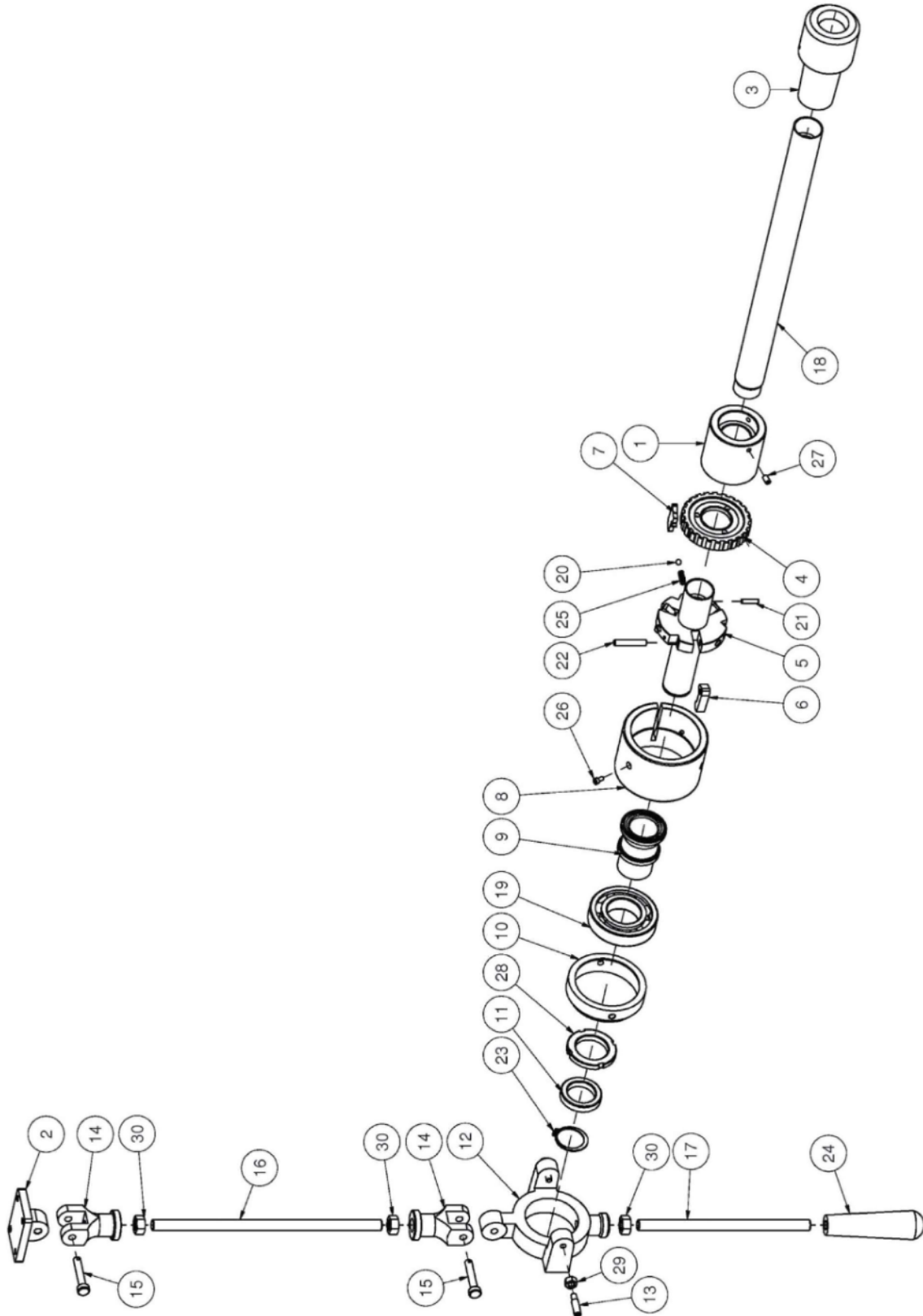



## COLLET CLOSER ASSEMBLY (OPTIONAL) PARTS LIST

Index No.	Part No.	Description	Size	Qty.
1	C51064006	Sleeve Coupling		1
2	C52302004	Fixed Seat (Length)		1
3	C53004118	Sleeve	#5	1
4	C54002038	Coupling		1
5	C54004047	Arbor		1
6	C54006001	Buckle		3
7	C54008007	Buckling Plate		1
8	C54012019	Outward Flange		1
9	C54014002	Bearing Shaft		1
10	C54016011	Bearing Stand		1
11	C54018020	Collar		1
12	C54020023	Bearing Body		1
13	C54021000	Set Screw		2
14	C54025015	Coupling		2
15	C54026005	Special Pin		2
16	C54027202	Stud	273L	1
17	C54029208	Lever Shaft	205L	1
18	C554920	Draw Bar	492L	1
19	BB-6208ZZ	Ball Bearing	6208ZZ	1
20	SB-6MM	Steel Ball	Ø6.0	1
21	5510484	Spring Pin	5 x 20L	1
22	GB050254	Spring Pin	1/4" x1-1/2L	3
23	GC020101	Retaining Ring (external)	32	1
24	GD020596	Grip	1/2"	1
25	GE040176	Spring		1
26	TS-1501021	Hex Socket Cap Screw	M4 x 8L	3
27	TS-1523031	Set Screw	M6 x10L	3
28	GF030823	Locking Nut	AN08	1
29	GF041946	Hex Nut	5/16"	2
30	GF041959	Hex Nut	1/2"	3
	892036	5C Collet Closer Assembly (#1 thru 30)		1

# STEADY REST ASSEMBLY

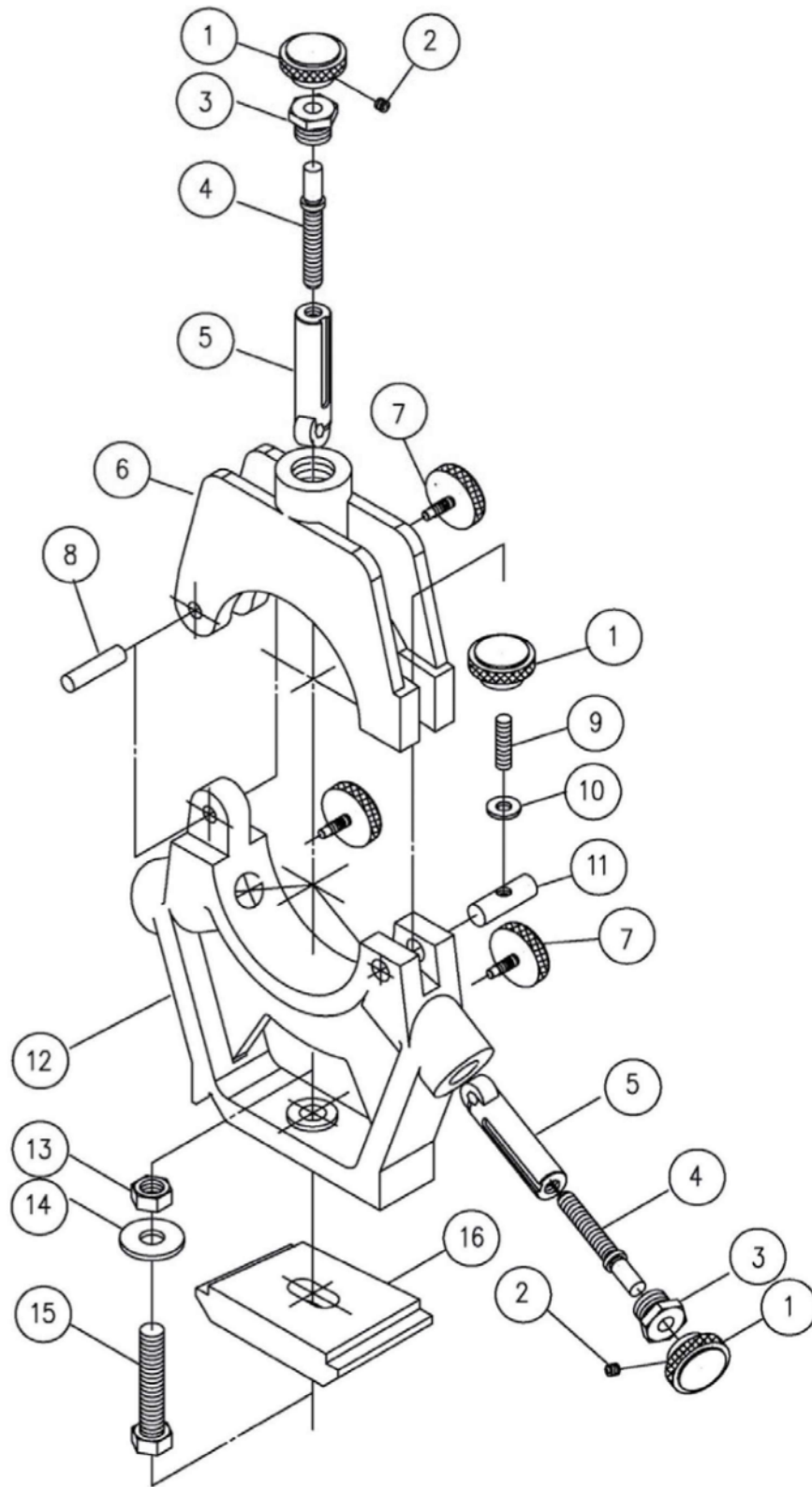

## STEADY REST ASSEMBLY PARTS LIST

Index No.	Parts No.	Description	Size	Qty.
1	E1440VS-FR01	Nut	Ø20xØ24x25L	4
2	TS-1523011	Set Screw	M6*6mm	3
3	E1440VS-FR03	Screw	Ø23x17L	3
4	E1440VS-FR04	Set Screw	Ø9.5x77L	3
	E1440VS-FR01A	Nut Assembly (includes #1~4)		3
5	E1440VS-FR05	Bearing Shaft	Ø18.8(Ø24)x83L	3
6	E1440VS-SR06	Arm	168x40x130 mm	1
7	E1440VS-FR07	Set Screw	Ø20xØ4.5x30L	3
8	E1440VS-SR08	Shaft	Ø8x40L	1
9	E1440VS-SR09	Set Screw	M8*55mm	1
10	TS-0732061	Washer	3/8 in	1
11	E1440VS-SR11	Pin	Ø12.7x40L	1
12	E1340VS-SR12	Base 13"	246x40x194	1
	E1440VS-SR12	Base 14"	247x40x194	1
13	TS-0561051	Hex Nut	1/2-13 in	1
14	TS-0680061	Flat Washer	1/2 in.	1
15	TS-0070071	Hex Cap Screw	12-13 x 2-1/2 in.	1
16	E1340VS-F31	Clamp Plate	106L*70W*22h	1
	E1340VS-SRA	Steady Rest Assembly for E-1340VS (#1~16)		
	E1440VS-SRA	Steady Rest Assembly for E-1440VS (#1~16)		

FOLLOW REST ASSEMBLY

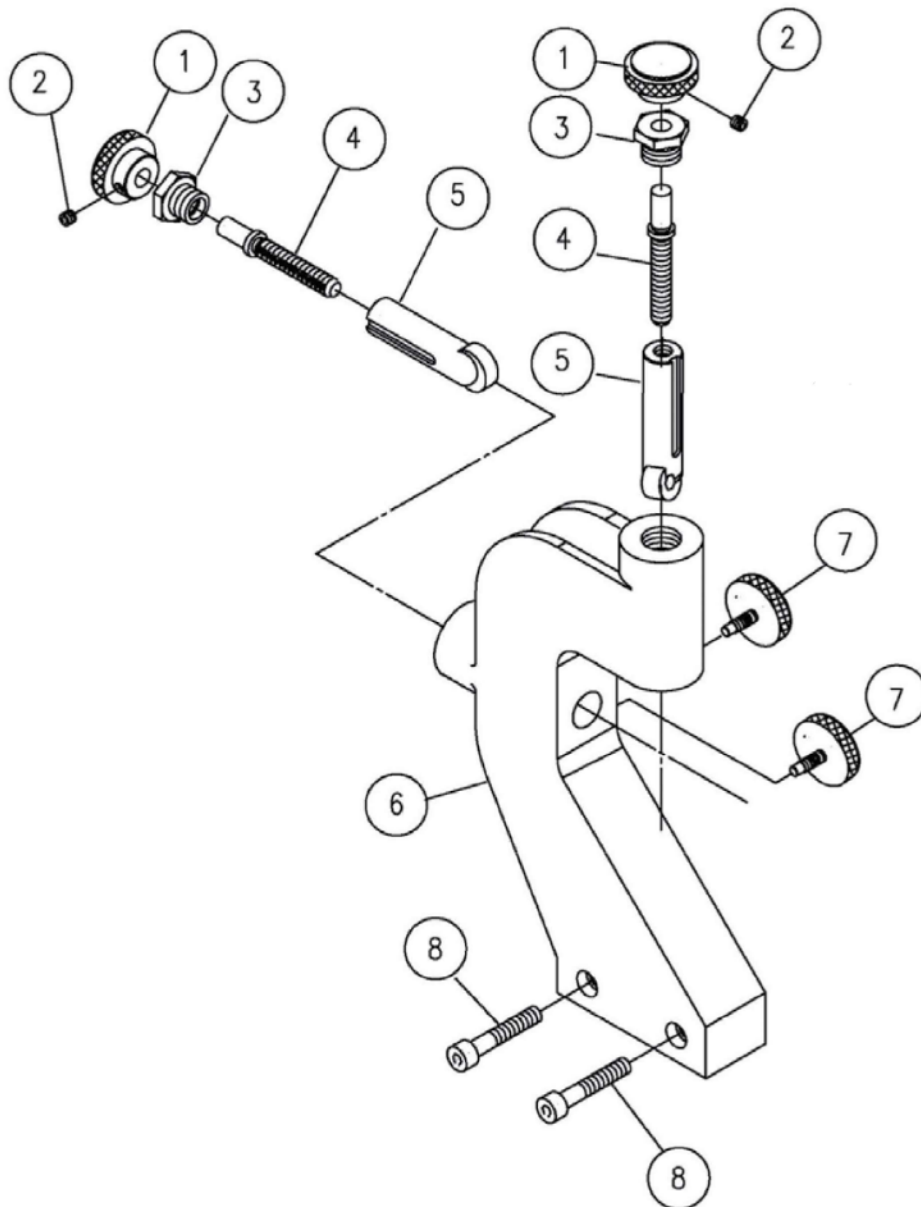

## FOLLOW REST ASSEMBLY PARTS LIST

Index No.	Parts No.	Description	Size	Qty.
1	E1440VS-FR01	Nut	Ø20xØ24x25L	2
2	TS-1523011	Set Screw	M6*6mm	2
3	E1440VS-FR03	Screw	Ø23x17L	2
4	E1440VS-FR04	Set Screw	Ø9.5x77L	2
	E1440VS-FR01A	Nut Assembly (includes #1~4)		2
5	E1440VS-FR05	Bearing Shaft	Ø18.8(Ø24)x83L	2
6	E1340VS-FR06	Follow Rest (for 1340VS)	174x40x280 mm	1
	E1440VS-FR06	Follow Rest (for 1440VS)	175x40x280 mm	1
7	E1440VS-FR07	Set Screw	Ø20(Ø4.5)x30L	2
8	TS-1490081	Socket Head Cap Screw	M8*45mm	2
	E1340VS-FRA	Follow Rest Assembly for E-1340VS (#1~8)		
	E1440VS-FRA	Follow Rest Assembly for E-1440VS (#1~8)		



# 11.0 WIRING DIAGRAMS

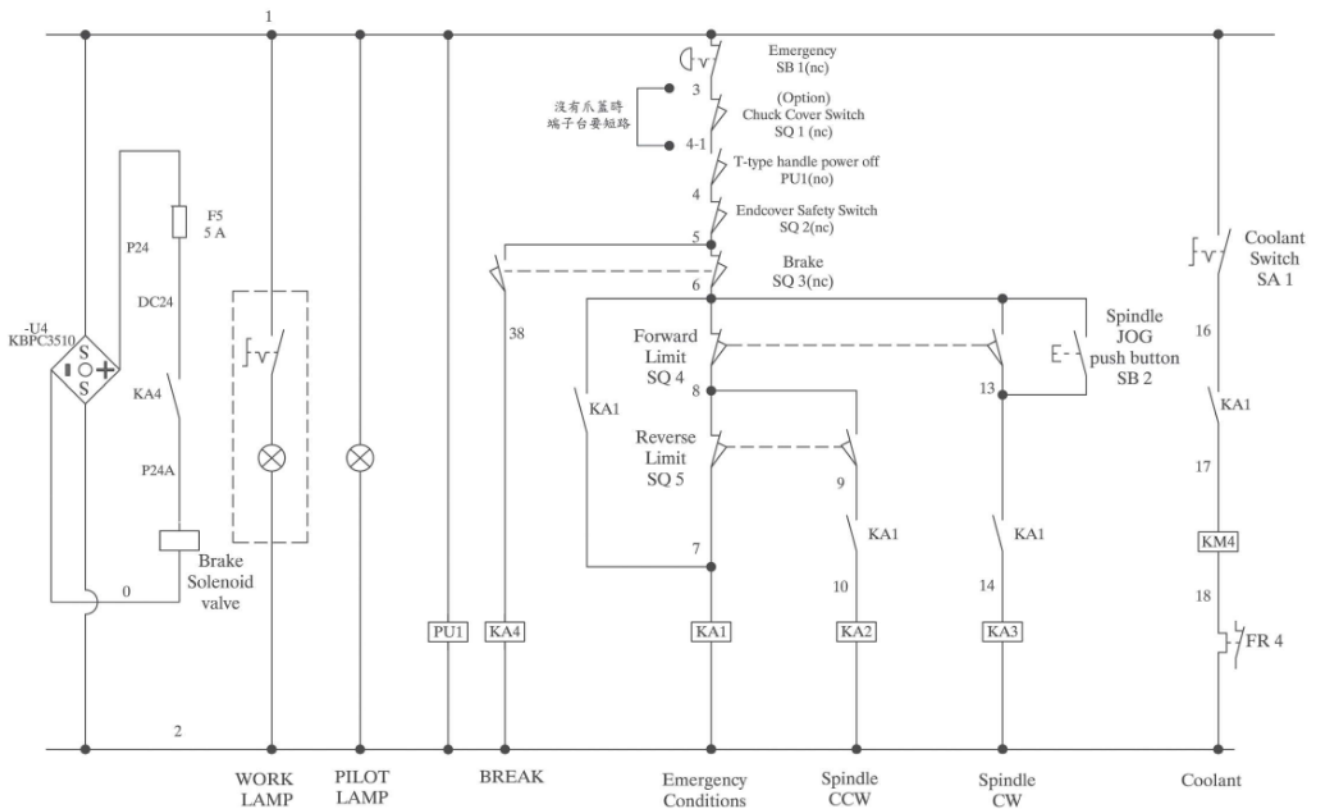
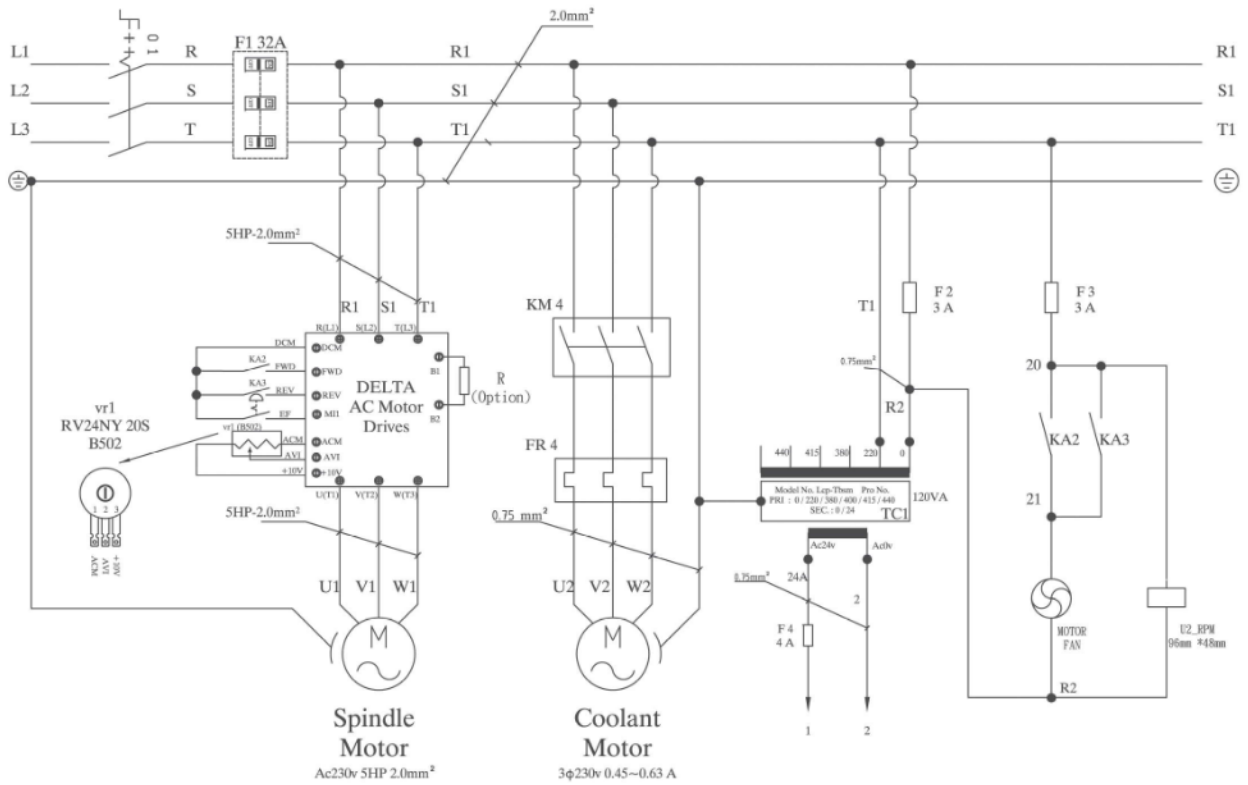

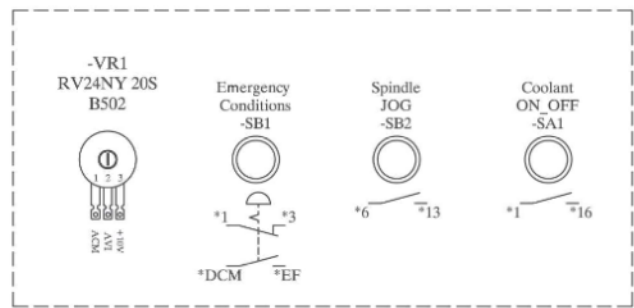
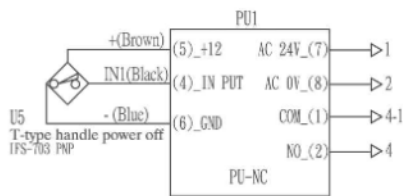
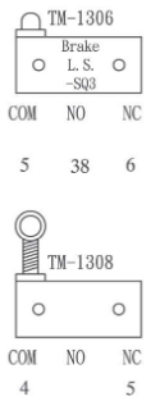
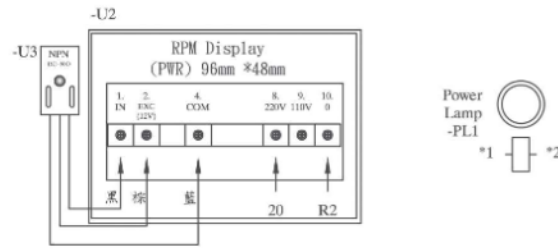
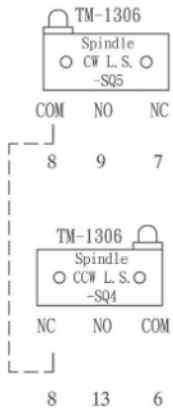

Endcover Safety Switch  
SQ 2(nc)



---

**NOTES**