

ITEM # SWDT63

TABLE ASSEMBLY

Identify all components before assembly. Do not tighten hex bolts until table has been completely assembled. Do not overtighten.

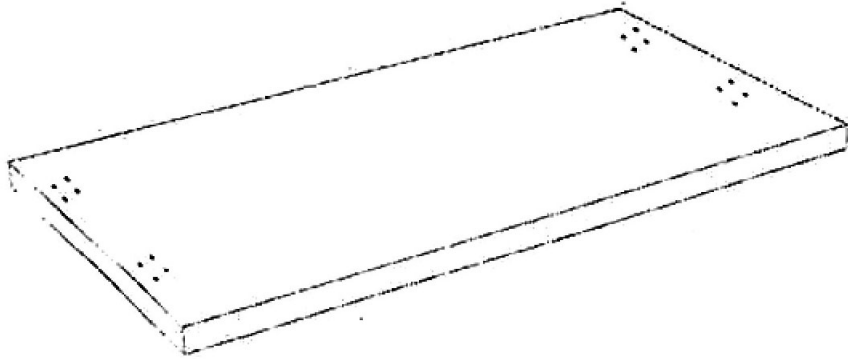

1) Lay tabletop on soft flat surface to prevent scratches. Position the bench so the bottom surface is visible.

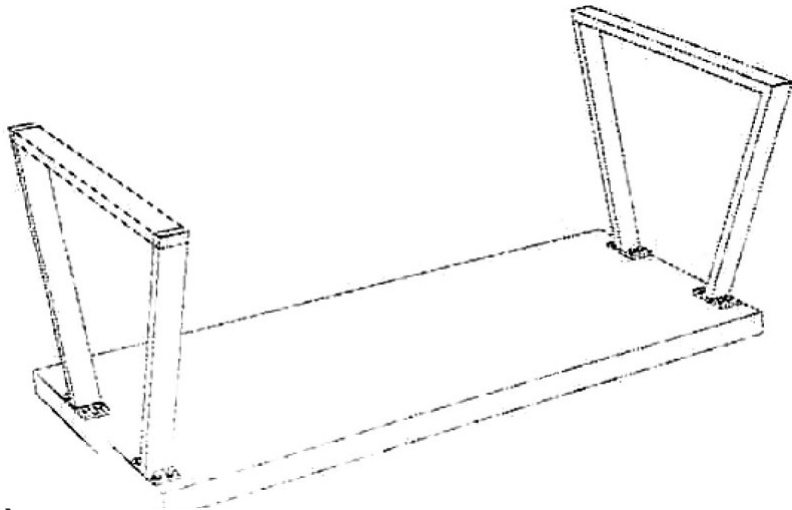

3) Position the remaining leg at opposite end. Secure each side with 4 hex bolts per leg.

COMPONENTS	
#1)	TOP 1 PIECE
#2)	LEGS 2 PIECES
#3)	HEX KEY 1 PIECE
#4)	HEX BOLTS 16 PIECES

WEIGHT CAPACITY
Table = 330 Lbs

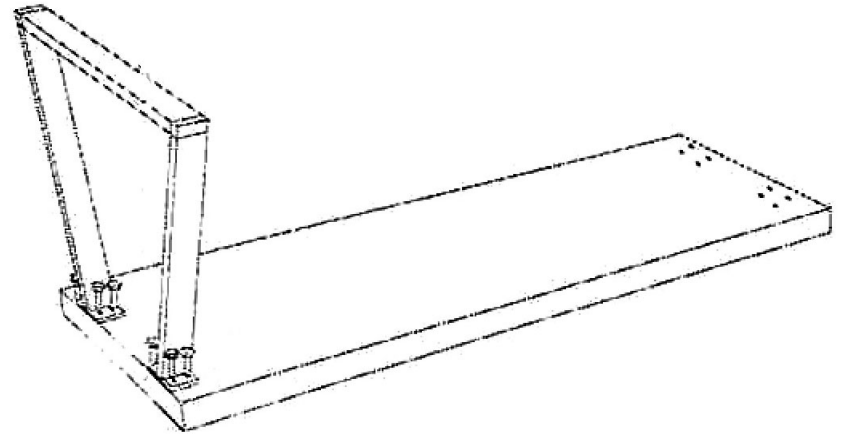

2) Place one set of legs at end of tabletop. Secure each side with 4 hex bolts per tabletop.

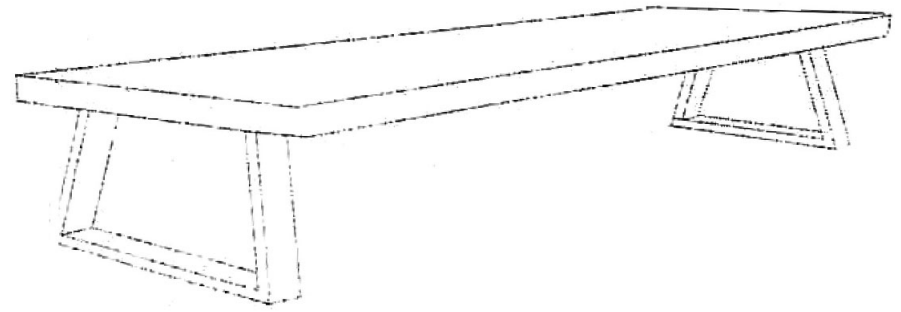

4) Securely tighten all hex bolts. Rotate tabletop.