

INSTRUCTIONS FOR ASSEMBLY, OPERATION, SERVICING & STORAGE

12 GALLON TRAILER SPRAYER



TABLE OF CONTENTS

TOOLS REQUIRED & INCLUDED HARDWARE	3
SPRAYER COMPONENTS	3
TRAILER SPRAYER ASSEMBLY	4
CALIBRATION	8
IMPORTANT SAFETY INFORMATION	8
GENERAL CHEMICAL SAFETY	8
BEFORE SPRAYING	9
DURING SPRAYING	9
AFTER SPRAYING	9
OPERATION - PREPARING & USING SPRAYER	9
PREPARING SPRAYER	10
USING SPRAYER	10
SPOT SPRAYING	10
BROADCAST SPRAYING	10
OPERATION - CLEANING, DECONTAMINATING & STORAGE	11
TROUBLESHOOTING	12
TROUBLESHOOTING TABLE	12
SPRAYER BREAKDOWNS	13

INTRODUCTION

Congratulations on the purchase of your 12 Volt Trailer Sprayer. This sprayer has been manufactured to provide years of dependable and efficient use in spraying a wide range agricultural pesticides, herbicides and other non-flammable liquids.

IMPORTANT NOTE:

THE PURPOSE OF THIS MANUAL IS TO ASSIST YOU IN THE ASSEMBLY, OPERATION, SERVICING AND STORAGE OF YOUR SPRAYER. PLEASE READ THROUGH THIS MANUAL COMPLETELY TOO FULLY UNDERSTAND HOW TO OPERATE AND MAINTAIN YOUR EQUIPMENT. KEEP YOUR MANUAL IN A SAFE, CONVENIENT PLACE FOR FUTURE REFERENCE. ALWAYS MENTION THE MODEL AND PART NUMBER IN ANY CORRESPONDENCE.

WARRANTY

Sprayers sold shall be warranted from defects in workmanship and material when used within the service and scope for which they were designed for a period of two years from date of purchase. Warranty covers replacement parts ONLY.

Contact our Spraying Division for warranty parts at 320-340-6464. DO NOT RETURN PRODUCT TO YOUR DISTRIBUTOR/DEALER. Please have original proof of purchase, model number of sprayer and part number of part from illustrated parts breakdown in this manual.



PHILLIPS SCREWDRIVER

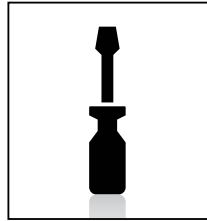

FLATHEAD SCREWDRIVER

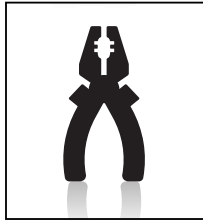

PLIERS



TEFLON TAPE

CLOSELY INSPECT ALL CONTENTS IN THE SHIPPING CARTON

- If you have damaged components: Contact the freight company that delivered the unit to file a claim.
- If you have missing components: Contact us at 320-340-6464.

INCLUDED HARDWARE

NOTE: SOME PARTS ARE SHIPPED INSIDE THE TANK!

SPRAYER COMPONENTS



Deflector Nozzle(1)
DF4.0



Nozzle Strainer(1)
NS-50



Nozzle Cap (1)
38027



Nozzle Nut (1)
3B12

SPRAYER COMPONENTS

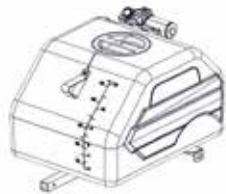

Sprayer Tank (1)



Spray Wand & Trigger Assy (1)
SG-4214-38BLK



Wheel (2)
TWA410-350-4-PU



Cotter Pin (2)
P-7922



Axel (1)
31-00335



Wire Harness (1)
33-103233



Drain Cap Tether (1)
33-103219



Drain Cap Gasket (1)
33-103220

SPRAYER COMPONENTS



Drain Cap (1)
33-103218



Snapper Hose Clamp (6)
SHC-E



Tongue (1)
32-100040



Tongue Pin (2)
905PA



Gun Clip Kit (1)
GC-100-KIT



Bracket Mount (1)
31-100352



Plumbing Assy. (1)



Drain Fitting (1)
31-100343



Suction Hose Assy. (1)
34-140181

1. PARTS



TOOLS

None

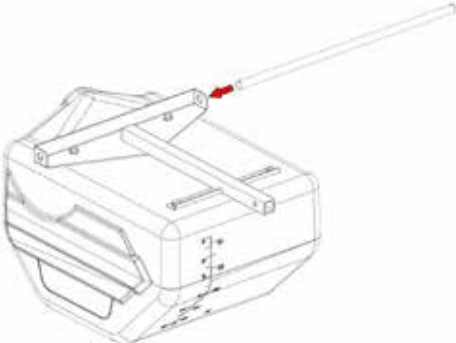

Attaches Axle to Frame



Turn Sprayer Tank upside down. Slide Axle through Frame holes until evenly spaced on each side of Frame.

2. PARTS

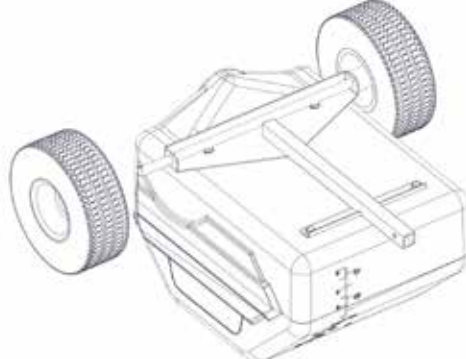

TOOLS

Insert Cotter Pin, then bend the ends out with Pliers.

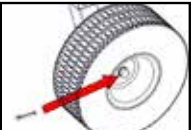

Attaches Wheels to Axel



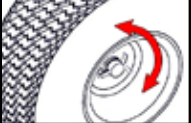
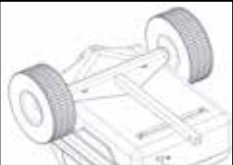

Slide the conical side of the Wheels on the Axel. Insert Cotter Pins through the holes in side of Axel. Use Pliers to bend the ends of the Cotter Pins. Spin Wheels to verify they won't rub against Sprayer Tank.

3. PARTS

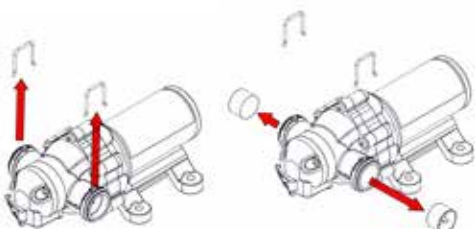

TOOLS

NOTE: There may be some water left over from testing at the pump factory.

Prepares Pump for Plumbing Installation

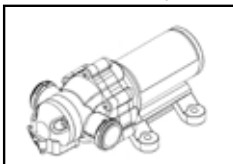

Remove Locking Clips from Diaphragm Pump Ports using a Flathead Screwdriver. Set aside for later use. Remove plastic plugs from Diaphragm Pump Ports and discard.

4. PARTS

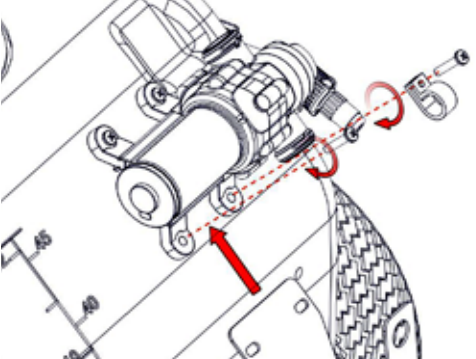

TOOLS

NOTE: For the screw that holds hose clamp to base of Diaphragm Pump, keep loose for assembly step #8.

Attaches Boom Nozzle Mount to Sprayer



Remove the two lower screws at Diaphragm Pump base with a Phillips Screwdriver. Slide Boom Mount under the Diaphragm Pump base. Re-insert screws and tighten securely. Do not over tighten.

5.

PARTS



TOOLS

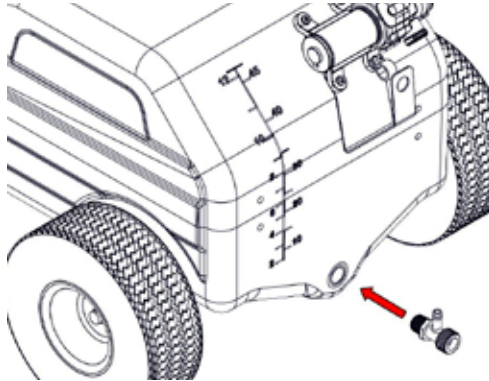

NOTE: Once threaded in place, the Drain Fitting should be tight and not easily moved by hand.

Attaches Drain Fitting to Sprayer Tank

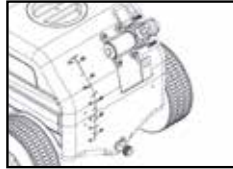

Obtain Drain Fitting and apply two complete revolutions of Teflon Tape to the 1/2" MNPT threaded side. Thread Drain Fitting into the open hole on the back of the Sprayer Tank. Should take 3 to 4 revolutions and make sure fitting is threaded on straight.

6.

PARTS



TOOLS

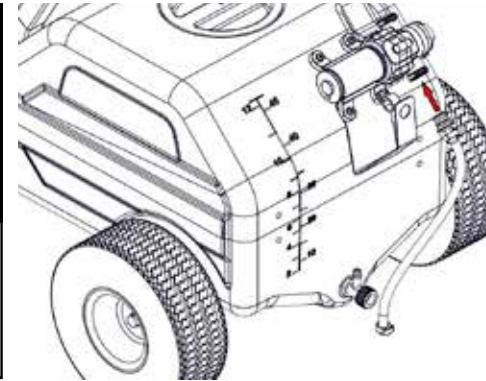

Attaches Hose Assembly to Sprayer

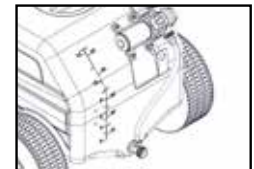

Insert the quick attach end of Intake Hose Assembly into the open Diaphragm Pump port. Insert one of the locking pins from Step 4 back into the Diaphragm Pump port. While supporting the Drain Fitting, push the other end of the Intake Hose Assembly over the barbed connection. Secure with Snapper Hose Clamps and tighten with Pliers.

7.

PARTS



TOOLS

None

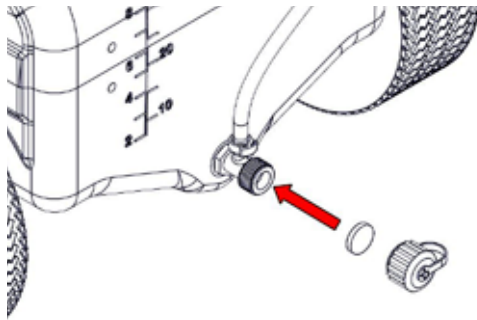

Installs Drain Cap Assembly

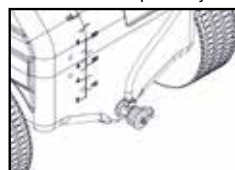

Press the Drain Cap Gasket into the Drain Cap until fully seated. Attach the Drain Tether to the top of the Drain Cap. Place other end of Drain Tether over tank drain outlet. Thread Drain Cap over drain until hand tight.

8.

PARTS



TOOLS

None

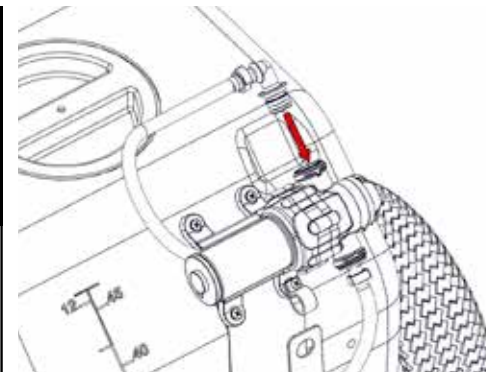

Connects Boom Plumbing To Pump

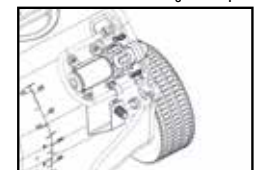

Locate Plumbing Assembly and route to the other open port on the Diaphragm Pump. Insert remaining locking pin from Step 4 into the Diaphragm Pump port.

9.

PARTS

TOOLS

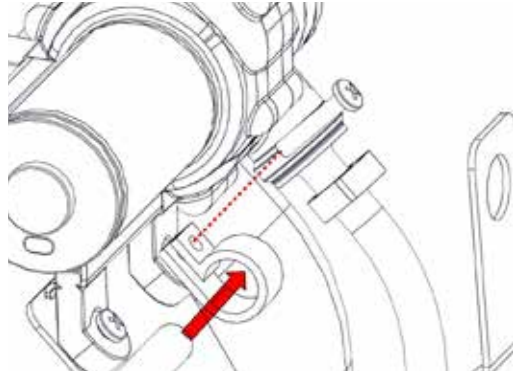

NOTE: Components of Plumbing Assembly removed in line drawing to show assembly clearly.

Secures Plumbing to Tank

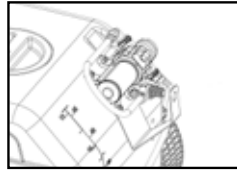

Using a Phillips Screwdriver, remove the loose screw that is holding the Hose Clamp onto the Diaphragm Pump Base. Slip Hose of Plumbing Assembly through Hose Clamp. Re-insert screw and tighten securely. Do not over tighten.

10.

PARTS

TOOLS

None

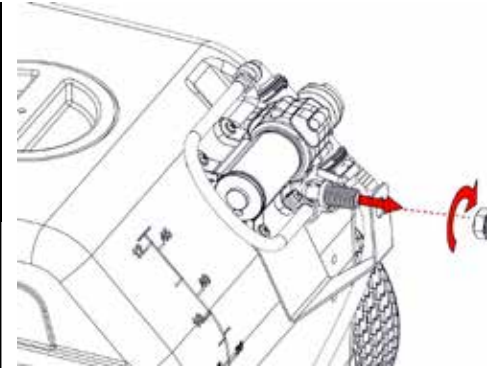

Connects Plumbing to Nozzle Mount

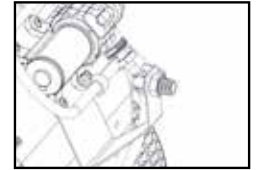

Attach threaded port end of Plumbing Assembly through the open hole on the Boom Mount. Thread Nozzle Nut onto open port.

11.

PARTS

TOOLS

None

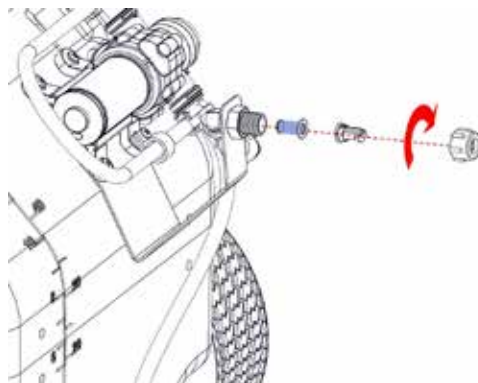

Assembles Spray Nozzle



Insert Nozzle Strainer into open port. Insert Deflector Nozzle into Nozzle Cap. Thread Nozzle Cap onto port. Confirm that Deflector Nozzle orifice is facing down. Tighten securely.

12.

PARTS

TOOLS

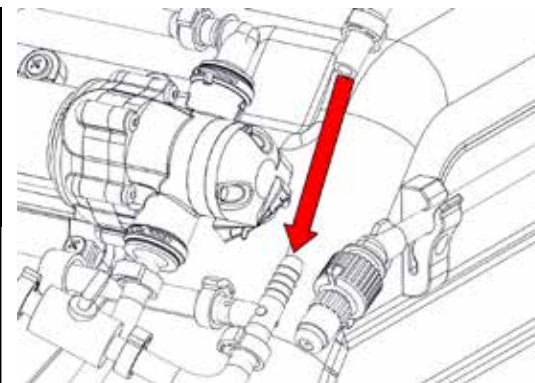

Connects Spray Gun Hose To Plumbing

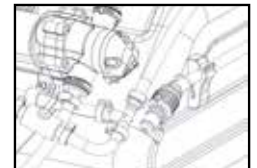

Locate the "T" hose barb fitting on plumbing. Push Hose of Spray Gun over the "T" hose barb. Secure with a Snapper Hose Clamp. Tighten with Pliers.

13. PARTS



TOOLS



None

Assembles Spray Gun



Thread Spray Gun shaft to the handle of Spray Gun. Tighten to ensure there will be no leaks when operating.

14. PARTS



TOOLS



None

Attaches Gun Clips to Sprayer Tank



Locate two screw holes on side of Sprayer Tank. With screws, install Gun Clips to side of Sprayer Tank. Be sure the open end is facing the top of Sprayer. Spray Gun can now be clipped into Gun Clips.

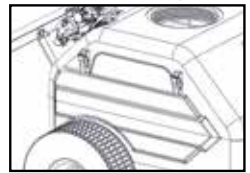

15. PARTS



TOOLS

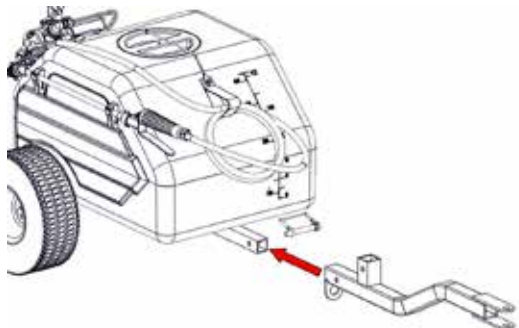

None

Attaches Tongue To Sprayer

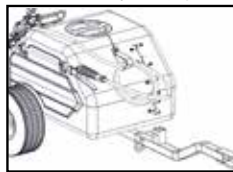

NOTE: Tongue can also be placed in the vertical position for easy storage.

Stand the Sprayer up on its Wheels and slide the Tongue over the open end of Trailer. Line up the Tongue and Trailer holes to insert and close the Locking Pin. A additional hitch is supplied for hitching to a vehicle receiver.

16. PARTS



TOOLS

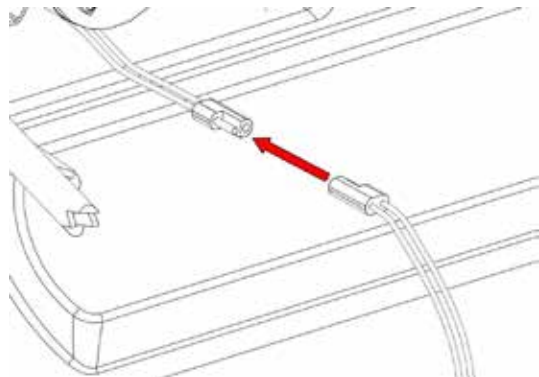

None

Connects Sprayer To Battery



NOTE: Connecting Wire Harness clamps to opposite posts will cause the pump to run backwards.

Connect Wire Harness to the Diaphragm Pump by pushing the two-pin terminal connectors together. Connect the red clamp to your battery's positive post and the black clam to the negative post.

Deflector Fan Spray Nozzles: The Deflector Fan Spray Nozzles on the boom will spray an 84" swath. The nozzle height should be approximately 15" above the object being sprayed.

Use the Tip chart below to determine the best application rates for your chemical. Please note there are three rates of application shown in the charts; Gallons per Acre, Gallons per 1000ft², Gallons per 100ft². Please refer to the one that matches your chemical label.

Height	PSI	1 MPH	2 MPH	3 MPH	4 MPH	5 MPH	7.5 MPH	10 MPH
		Gallons Per Acre						
15"	30	139.6	69.8	46.5	34.9	27.9	18.6	14
		Gallons Per 1000 ft ²						
15"	30	3.20	1.60	1.07	0.80	0.64	0.43	0.32
		Gallons Per 100 ft ²						
15"	30	0.32	0.16	0.11	0.08	0.06	0.04	0.03

Once you know how much you are going to spray, determine (from the top chart) the spraying pressure(PSI) and the spraying speed (MPH)

When selecting pressure from the top chart, it is a good idea to try for the 30 PSI range as this allows and excellent nozzle pattern. At 10 PSI the pattern begins to break up and at 40 PSI you may notice some drift. Conditions of weather and terrain must be considered when setting the sprayer. Do not spray on windy days. Protective clothing must be worn in some cases. Be sure to read the chemical label carefully.

After all calibrations have been completed, add water and chemical to the tank. Always follow chemical manufacturer's instructions for mixing. Conditions of weather and terrain must be considered when setting the sprayer. Do not spray on windy days. Protective clothing must be worn in some cases. Be sure to read the chemical label carefully.

GALLONS PER ACRE, 40" SPACING									
Nozzle	PSI	GPM	4 MPH	5 MPH	6 MPH	7 MPH	8 MPH	9 MPH	10 MPH
DF4.0 White	15	0.37	13.7	11.0	9.2	7.8	6.9	6.1	5.5
	20	0.42	15.6	12.5	10.4	8.9	7.8	6.9	6.2
	30	0.52	19.3	15.4	12.9	11.0	9.7	8.6	7.7
	40	0.60	22.3	17.8	14.9	12.7	11.1	9.9	8.9
	60	0.73	27.1	21.7	18.1	15.5	13.6	12.0	10.9

OPERATION - IMPORTANT SAFETY INFORMATION

Now that you have assembled your sprayer, there is some important safety and health information you need to know with regard to handling and spraying chemicals.



TAKE NOTE! THIS SAFETY ALERT SYMBOL FOUND THROUGHOUT THIS SECTION IS USED TO CALL YOUR ATTENTION TO INSTRUCTIONS INVOLVING YOUR PERSONAL SAFETY AND THE SAFETY OF OTHERS. FAILURE TO FOLLOW THESE INSTRUCTIONS CAN RESULT IN PROPERTY DAMAGE, INJURY OR DEATH.

NOTE: THE USE OF CORROSIVE OR FLAMMABLE CHEMICALS IN THIS SPRAYER IS HAZARDOUS AND WILL ALSO VOID YOUR WARRANTY.

GENERAL CHEMICAL SAFETY

WARNING

Pesticides are hazardous chemicals. Heed the warning below and follow all instructions carefully. Improper handling of chemicals can result in serious injury or illness, or cause damage to humans, animals or the general environment.

BEFORE SPRAYING

- **Sprayer Prep:** ALWAYS inspect and prepare the sprayer before use according to the directions provided in this manual.
- **Keep Sprayer Off:** Do not turn power on to the sprayer until ready to spray in order to avoid unintentional spray release.
- **Broadcast Nozzle Down:** Make sure the broadcast nozzle is oriented to spray straight down before starting the sprayer.
- **Wind Speed:** NEVER spray when wind exceeds 4 MPH in order to minimize spray drift.
- **Clear Area:** ALWAYS keep work area clear of people and pets. Post warning notices to restrict access by the public for the period recommended on chemical label.
- **Operator Age:** To operate this sprayer, you must be 16 years of age or older. Pesticides are extremely toxic to children.
- **Chemical Label:** ALWAYS READ and FOLLOW all chemical label instructions.
- **State & Federal Laws:** ALWAYS refer to state and federal regulations with regard to the application of a particular chemical you plan to use.
- **Flammables:** NEVER use any flammable chemicals, such as diesel fuel, in the sprayer.
- **Corrosives:** DO NOT use corrosive chemicals, such as bleach, in the sprayer. They can weaken the sprayer and its parts, resulting in leaks. Always check with chemical manufacturer for compatibility with sprayer.
- **Emergency Procedures:** Before handling chemicals, carefully review the "Statement of Practical Treatment" on the chemical label.

DURING SPRAYING

- **Over Application:** DO NOT over apply pesticide. Apply at a rate recommended by chemical manufacturer. Excess pesticide can be dangerous to humans, damage desirable plants, and contaminate soil and water sources.
- **Never Point Spray Gun:** NEVER point the spray gun at people or animals.
- **Children & Pets:** ALWAYS exercise extra caution when spraying near areas accessible to children and pets.
- **Eating & Smoking:** DO NOT eat, drink, smoke, rub your eyes or touch any part of your bare skin while handling chemicals and spraying.
- **Heat & Flames:** DO NOT spray near open flames or sources of heat.
- **Spills:** ALWAYS clean up spills immediately per instructions on the chemical label.
- **Unattended:** ALWAYS turn off vehicle and set brake or block wheels, turn off power to sprayer, and relieve system pressure before leaving sprayer unattended.

AFTER SPRAYING

- **Clean Sprayer:** ALWAYS clean the sprayer immediately after use according to the directions provided in this manual.
- **Decontaminate:** ALWAYS decontaminate yourself immediately after you are finished with spraying and handling chemicals. Wash all exposed areas of the body with soap and water. Remove and launder clothing.
- **Chemical Disposal & Storage:** ALWAYS dispose or store remaining chemicals properly as recommended on the chemical label.
- **Health Monitoring:** Monitor the health of operators who are frequently exposed to pesticides, as recommended by the chemical label.



WARNING

Chemical spills, sprayer leaks, personal contamination, and poisoning are accident situations which you may encounter. All require an immediate response. In the event these accidents take place, follow first aid instructions on the chemical label and contact poison control for further advice (1-800-222-1222). If victim collapses or isn't breathing CALL 911.

OPERATION - PREPARING & USING SPRAYER

If the sprayer has been used previously, it must be prepared BEFORE EACH SUBSEQUENT USE.



WARNING

Read the following instructions carefully for inspecting and using the sprayer. Damaged or clogged equipment could result in leaks or uncontrolled spray. Leaks could result in injury to the operator or bystanders from chemical exposure, or cause damage to the environment.

IMPORTANT NOTE:

THIS SPRAYER IS NOT CERTIFIED FOR USE IN DISPENSING POTABLE WATER OR OTHER CONSUMABLE LIQUIDS.

PREPARING SPRAYER

- **Review Safety Information:** Review safety information in this manual and manufacturer chemical label before use.
- **Sprayer Attachment:** Ensure the sprayer is securely attached to the vehicle.
- **Empty Tank:** Ensure the sprayer has been thoroughly flushed and drained of all residual chemical prior to uses.
- **Clean Suction Strainer:** Clean suction strainer of any chemical residue with fresh water. USE RUBBER GLOVES for extra safety.
- **Inspect & Test:** Inspect the tank and components for any cracks or leaks. Replace any damaged parts. **IMPORTANT:** After any repair, **ALWAYS** test for leaks with water one final time before use.
- **Check Drain Cap:** Before filling tank, ensure drain cap at bottom of tank is securely tightened.

USING SPRAYER

- **Protective Equipment:** **ALWAYS** wear protective equipment as directed on the chemical label.
- **Assess Wind & Area Conditions:** Before spraying, determine if wind conditions are suitable. **DO NOT** spray if wind speeds are greater than 4 MPH. **DO NOT** spray if bystanders are in the intended area and verify that area is in a well-ventilated outdoor area.
- **Power Off:** Before filling tank, make sure power to the sprayer and the vehicle is off and brakes are set to prevent unintended movement.
- **Filling Tank:** Remove sprayer tank lid and add chemical/water dilution ratios that are called out by chemical label. Ensure chemical is thoroughly mixed with a stirring device and then securely thread tank lid back on sprayer tank.

USING SPRAYER (CONTINUED)

- **Broadcast Boom Valve:** Close broadcast boom valve to prevent accidental spray release.
- **Turn On Power:** Connect the wire harness to vehicle battery and turn the remote switch to the “On” position.

SPOT SPRAYING

- **Spot Spraying:** To spot spray, pull the gun trigger. Make sure nozzle of gun is pointed towards vegetation in need of spraying.
- **Adjustable Nozzle:** Twist the spray nozzle to adjust from a straight stream to wide pattern mist.
Note: It is not unusual for the operator to be exposed to chemical drips while adjusting the nozzle – use chemical resistant gloves when twisting.

BROADCAST SPRAYING

- **Open Boom Valve:** Open up boom valve to allow flow from tank to boom kit.
- **Ensure Correct Pattern:** Make sure boom nozzle is pointed straight down. If not, loosen the nozzle retaining nut and adjust orientation of the boom nozzle opening to point straight down.
Note: It is not unusual for the operator to be exposed to chemical drips while adjusting the broadcast nozzle. Chemical resistant gloves should be worn.
- **Open Boom Valve:** Open up boom valve to allow flow from tank to boom kit.
- **Uniform Coverage:** To ensure proper coverage, follow the separate boom kit manual that came with your sprayer.
- **Broadcast Spraying:** Turn the remote switch to the “ON” position to being spraying.

OPERATION - CLEANING, DECONTAMINATING & STORAGE

When done using the sprayer, it is always important to clean the sprayer and decontaminate yourself. Do not store the sprayer with chemicals in the tank, as it is unsafe and could also result in damage.



WARNING

Clean-up and decontamination procedures must be followed after each use. Improper equipment clean-up and disposal of chemicals can result in dangerous chemical exposure to humans and the environment, as well as equipment damage. Personal decontamination is required after spraying to minimize unsafe exposure to chemicals and potential illness.

CLEANING & DECONTAMINATING SPRAYER

- **Drain Tank:** If there is excess pesticide left in tank, drain into a suitable container.
Note: when draining pesticides, be sure to wear protective gear such as rubber gloves and eye protection for increased safety.
- **Unused Chemical:** Properly store or dispose of unused chemical in its original, suitable container and make sure to follow chemical manufacturer's recommendations and according to local hazardous waste disposal regulations.
- **Flush Sprayer:** Flush sprayer per the chemical manufacturer's recommendations.
- **Decontaminate & Launder:** Decontaminate yourself after handling chemicals by removing clothing worn, washing exposed body parts with soap and water, and laundering clothing separately from other wash.

SPRAYER STORAGE

Prepare the sprayer for end-of-season storage by running RV anti-freeze through the system. This will keep internal parts lubricated, protect against corrosion, and keep the unit from freezing.

IMPORTANT NOTE:

ALLOWING YOUR SPRAYER TO FREEZE, WITHOUT TAKING PROPER WINTERIZATION STEPS, VOIDS YOUR WARRANTY.



WARNING

The sprayer will be damaged if it freezes. Protect the sprayer from freezing during storage by following instructions below.

PREPARING SPRAYER FOR STORAGE

- **Add Anti-Freeze:** Pour one gallon of RV anti-freeze into the sprayer tank.
- **Spray Briefly:** Turn on the pump motor and squeeze the gun trigger briefly until fluid sprays out.

REMOVING SPRAYER FROM STORAGE

- **Drain Anti-Freeze:** Drain the anti-freeze that is left in the tank through the tank drain port into a suitable container.
- **Flush with Water:** Fill tank with fresh water and have it run through system. Operate spray gun and boom until the system is completely flushed. Be sure to set up containers to capture the flushing of the anti-freeze.
- **Disposal:** Dispose of anti-freeze and flush water properly.

TROUBLESHOOTING

Here you will find troubleshooting steps for some of the most common issues users have with sprayers.



WARNING

Before troubleshooting or attempting to service your pump or sprayer, read the following safety rules to avoid accidental exposure to chemicals and the possibility of electric shock.

BEFORE ATTEMPTING TO SERVICE SPRAYER

- **Personal Protective Equipment:** Wear personal protective equipment as directed on the chemical label while servicing sprayer.
- **Review Troubleshooting Table:** Review the troubleshooting table to the right for the type of problem you are experiencing. DO NOT attempt to repair until reading remaining steps listed below are followed.
- **Empty & Flush Tank:** Empty the tank and flush the sprayer with water as directed in the section Cleaning, Decontaminating & Storage.
- **Disconnect Power/Relieve Pressure:** Disconnect power to the sprayer and be sure all system pressure is relieved by squeezing the gun trigger.
- **Perform Repairs:** Follow the directions provided in the troubleshooting table to repair the sprayer.
Note: Never try to unclog the sprayer nozzle by blowing through it.
- **Test after Repairs:** After repairs, ALWAYS test the sprayer for leaks with fresh water before using.

PROBLEM	CAUSE	SOLUTION
Pump Will Not Turn On	Bad Electrical Connection	Check Battery Connections
	Fuse Blown	Replace Fuse
	Short In Wire	Check Condition of Wires
	Low Voltage	Check Voltage
	Locked Drive	Replace Diaphragm Assembly
	Faulty Pressure Switch	Replace Pressure Switch
Pump Will Not Prime	Out of Product	Refill Supply Container
	Inlet Air Leak	Tighten Fittings or Replace Cracked Fittings
	Inlet/Outlet Tube Obstruction	Remove Obstruction
	Clogged Intake Valve	Remove Obstruction
	Low Voltage	Check Voltage
Low Pressure or Flow	Worn Spray Gun Nozzle	Replace Spray Gun
	Worn Boom Nozzle	Replace Boom Nozzle
	Worn Wobble Plate or Diaphragm	Replace Diaphragm Assembly
	Worn Pressure Switch	Replace Pressure Switch
	Inlet Air Leak	Tighten Fittings or Replace Cracked Fittings
	Inlet/Outlet Tube Obstruction	Remove Obstruction
	Clogged Intake Valve	Remove Obstruction
	Low Voltage	Check Voltage
Pump Leaks	Loose Fasteners	Tighten Fasteners
	Pump Seals Degraded	Replace Pump Head Assembly
	Leak In Diaphragm	Replace Diaphragm Assembly
Poor Spray Distribution	Clogged Intake Tube	Remove Obstruction
	Clogged Suction Strainer	Clean Suction Strainer
	Worn Spray Gun Nozzle	Replace Spray Gun
Pump Cycles While Not Spraying	Leak In the System	Tighten Leaking Hose Clamps, Fittings or Replace Spray Gun
	Faulty Pressure Switch	Replace Pressure Switch
	Low Voltage	Check Voltage
	Air Trapped In System	Purge Air From System
Rough Operation	Flexible Mounting Surface	Mount Pump On Rigid Surface
	Loose Pump Head	Tighten Fasteners
	Compressed Base Feet	Decompress Base Feet
	Rigid Plumbing	Plumb Pump with Flexible Plumbing

12 GALLON TRAILER SPRAYER BREAKDOWN

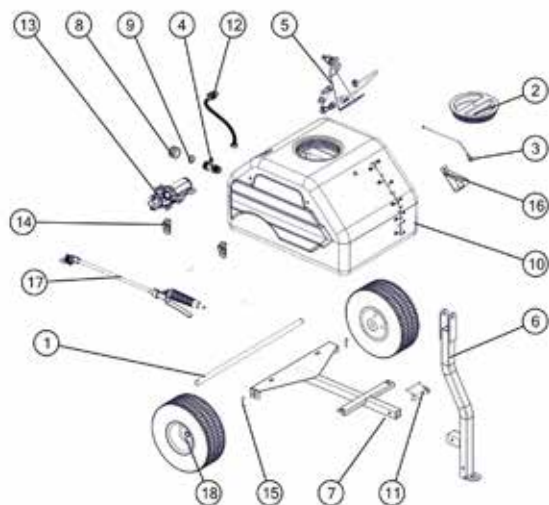

ID	Part Number	Description	Qty
1	31-100335	Axel	1
2	31-100340	Tank Lid	1
3	31-100341	Lid Tether	1
4	31-100343	1/2 MNPT x 3/4 GHT x 3/8 HB Fitting	1
5	31-100352	Nozzle Bracket	1
6	32-100040	Offset Tongue	1
7	32-100110	12 Gallon Trailer Frame	1
8	33-103218	3/4" Outlet Cap	1
9	33-103220	3/4" Gasket	1
10	33-103836	12 Gallon Tank	1
11	905PA	Lock Pin	1
12	34-140181	Intake Hose Assembly	1
13	EF1100-QA	1.1 GPM Everflo QA Pump	1
14	GC-100-KIT	Gun Clip Kit	1
15	P-7922	hair Pin	2
16	RTS2.0-14.125	Hose Organizing Strap	1
17	SG-4214-38BLK	14" Spray Gun	1
18	TWA410-350-4-PU	Foam Filled Tire Assemblies	2

NOZZLE & PLUMBING BREAKDOWN

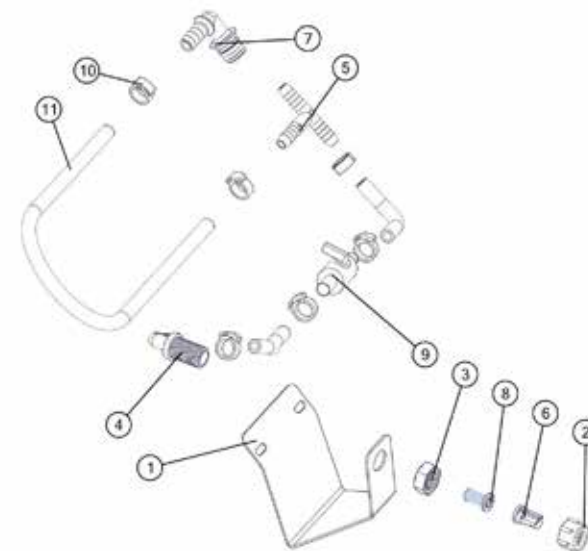

ID	Part Number	Description	Qty
1	31-100352	Bracket Mount	1
2	38027	Nozzle Nut - 11/16" FPS	1
3	3B12	Nozzle Nut - 11/16"	1
4	3NLT38-C	Elbow - 11/16" MPS x 3/8" HB	1
5	3T38	Tee - 3/8"HB	1
6	DF4.0	Deflector Nozzle - White	1
7	EF-QC-EL38	Elbow - QA x 3/8" HB	1
8	NS-50	Nozzle Strainer - 50 Mesh	1
9	PBV-38HB	Ball Valve - 3/8" HB	1
10	SHC-E	Snapper Hose Clamps	6
11	33-103938	Vinyl Braided Hose - .37 x .59	1

PLEASE FOLLOW ALL WARNINGS IN THIS MANUAL, FAILURE TO DO SO COULD RESULT IN PROPERTY DAMAGE & INJURY.

