



We Power Your World!

*Owner's Manual of Generator for*  
**GN5250DCS**



Green-Power America, LLC



## Products Service Information

Green-Power America LLC thanks you for choosing a Green-Power America LLC product.

Please register your product within 10 days of purchase to ensure that you receive optimal service. Always keep copy of your original receipt.

By registering your product, you are protected:

1. You have a record of the product purchase,
2. Customer Service can better serve you on warranty related issues,
3. Green Power America will be able to contact you in the unlikely event that a product recall notification is necessary.

You can register your product in one of two ways as follows:

**Option 1:** Go to the Green Power America website at [www.green-poweramerica.com/service](http://www.green-poweramerica.com/service) and follow the instructions to register online.

**Option 2:** Fill out the form on the Warranty Card included in the box, and return via standard mail to Green Power America at 840 9th Street Suite H, Upland CA 91786.

Please note that postage is required to mail the registration form back to Green Power America.

If you still have any questions regarding the usage or operation of your generator after you have carefully read the manual, or if you have any quality issues during operation, please call our toll-free service number shown below:

**877-834-4218**

---

# 5250W Dual Fuel Generator

---

## Table of Contents

Topic	Page
Limited Warranty	3
Specifications	6
Safety Guidelines	7
General Precautions	8
Assembly and Installation	17
Operation	20
Inspection, Cleaning, Maintenance and Storage	25
Carbon Monoxide Protecting System (CO-Seizer™ System)	30
General Parts Listing	31



**WARNING! READ AND UNDERSTAND ALL SAFETY PRECAUTIONS IN THIS MUANUAL BEFORE OPERATING. FAILURE TO COMPLY WITH INSTRUCTIONS IN THIS MANUAL COULD RESULT IN PERSONAL INJURY, PROPERTY DAMAGE, AND/OR VOIDING OF YOUR WARRANTY. GREEN-POWER AMERICA, LLC (HEREINAFTER IN SHORT "GREEN-POWER" OR "GPA") WILL NOT BE LIABLE FOR ANY DAMAGE BECAUSE OF FAILURE TO FOLLOW THESE INSTRUCTIONS.**

## Limited Warranty

### WARRANTY POLICY -- GENERATOR

#### Two(2)-YEAR LIMITED WARRANTY or One(1)-YEAR LIMITED WARRANTY

**Green-Power America, LLC (GPA) provides Two(2)-Year or One(1)-Year (GPD1500 and GN1750D) limited factory warranty once consumers buy the generator from GPA or any of GPA partners in the United States.**

#### 1, Warranty Qualifications

Green-Power America, LLC (GPA) will register this warranty upon receipt of your Warranty Registration Card / Warranty Registration on Web and a copy of your sales receipt from one of GPA's retail locations as proof of purchase. GPA strongly recommend consumer keeps the purchasing receipt as a proof.

Please submit your warranty registration and your proof of purchase within ten (10) days of the date of purchase.

#### 2, Clarification of Two(2)-Year Limited Warranty or One(1)-Year Limited Warranty

- ✓ Two(2)-Year Limited Warranty: For household use, from the original date of purchase, the warranty is clocked and the parts and repairing labor will be free in the 1st year, and parts only will be free in the 2nd year.

If the product is used for commercial or industrial purpose, including but not limited to be used in commercial or industrial site, rental and any other types of income earning, the original Two(2)-Year Warranty will be expired and becomes Ninety(90) days instead, the parts will be free during this period.

- ✓ One(1)-Year Limited Warranty (Apply to GPD1500, GN1750D): For household use only, from the original date of purchase, the warranty is clocked and the parts will be free in the 1st year.

If the product is used for commercial or industrial purpose, including but not limited to be used in commercial or industrial site, rental and any other types of income earning, the original One(1)-Year Warranty will be expired and becomes Thirty(30) days instead, the parts will be free during this period.

- ✓ **GPA will provide all parts for replacement in whole lifetime of the product, material cost and transportation cost will apply if it is beyond of warranty period or not covered by the warranty policy.**

#### 3, Repair/Replacement Warranty

GPA warrants to the original purchaser that the mechanical and electrical components will be free of defects in material and workmanship for a period of the 1st year from the original date of purchase for Two(2)-Year Warranty items household use. Parts are always free during warranty period. Transportation charges for the unit repair or replacement under this warranty will be sole responsibility of the consumer. This warranty only applies to the original purchaser only and is not transferable.

---

# 5250W Dual Fuel Generator

---

## Limited Warranty

Contact GPA's Service Center and GPA will troubleshoot any issue via phone (Toll-Free: 877-834-4218) or e-mail ([service@green-poweramerica.com](mailto:service@green-poweramerica.com)). If the issue is not fixed, GPA will, at its option, authorize evaluation, repair or replacement of the defective parts or components at a GPA Service Center. GPA will provide you with a case number.

for warranty service. Please keep it for future reference. Repairs or replacements without prior authorization, or at an unauthorized repair facility, will not be covered by this warranty.

### 4, Return Policy and Procedure

#### ✓ Defective Return

If the defective unit can not be repaired by the authorized repair center and the unit was within one (1) year, GPA will make a decision, on GPA sole options, either replace it with an equivalent or return it to GPA and consumer will get refund. The refund amount will be determined by the used time as below:

- Within thirty (30) days from the original purchasing date, full amount will be refunded.

- For Two(2)-Year Warranty items household use only, from thirty-one (31) days but within one (1) year from the original purchasing date, the refund proportion will be determined by 100% minuses its actual using months divided by twelve (12).

Formula: Refund Proportion =  $100\% - \text{number of used month} / 12 * 100\%$

#### ✓ Remorse Return

If consumer wants to return due to consumer's mind changing or any other non-quality reason, which is called **Remorse Return**, and the unit is in its original packing condition or consumer opened the original package but never fill the fuel and/or oil into the unit, and the unit could be repacked properly, within thirty (30) days from the original purchasing date, GPA will provide a Return Goods Authorization number (RGA #) to the retailer to accept the return for refund. Consumer will pay the return freight and 15% of the retail price (excluding tax) for re-stock fee. The consumer should contact the retailer with GPA's RGA# and will get remaining amount refunded after the return is received by GPA. The return address will be noted by GPA when the RGA# is provided.

#### Attention please:

**Do Not Return The Unit To The Place Of Purchase even** unless the retailer / distributor has a certain agreement with GPA in written.

**All refund will be issued in terms of Credit Memo (CM) to the retailer/distributor, and the consumer will get refund from the original store.**

### 5, Warranty Exclusions

This warranty does not cover the following repairs and equipment:

#### ✓ Normal Wear and Tear

Products with mechanical and electrical components need periodic parts and service to perform well, including but not limited, filter elements, o-rings, spark plug, rubber mounts, etc. This warranty does not cover repair when normal use has exhausted the life of a part or the equipment as a whole.

#### ✓ Installation, Use and Maintenance

## Limited Warranty

--This warranty will not apply to parts and/or any labor of installation.

--This warranty will not apply to parts and/or any labor if the product is deemed to have been misused, neglected, involved in an accident, abused, loaded beyond the product's limits, modified, installed improperly or connected incorrectly to any electrical component.

--Normal maintenance is not covered by this warranty and is not required to be performed at a facility or by a person authorized by GPA.

\* Except as otherwise stipulated in any of the following enclosed Emission Control System Warranties

(if applicable) for the Emission Control System: U.S. Environment Protection Agency (EPA), California Air Resources Board (CARB) and/or Environment Canada (EC).

✓ Other Exclusions

This warranty excludes:

–Cosmetic defects such as paint, decals, etc.

–Accessory parts such as starting batteries, tools and storage covers.

–Failures due to acts of God and other force majeure events which beyond the manufacturer's control.

–Problems caused by parts that are not original Green-Power America (GPA) parts.

When applicable, this warranty does not apply to products used for prime power in place of a utility.

## 6, Limits of Implied Warranty and Consequential Damage

Green-Power America (GPA) disclaims any obligation to cover any loss of time, freight, or any incidental or consequential claim by anyone due to using this generator. **THIS WARRANTY AND THE ATTACHED U.S. EPA, CARB and/or EC EMISSION CONTROL SYSTEM WARRANTIES (IF APPLICABLE) ARE IN LIEU OF ALL OTHER WARRANTIES, EXPRESS OR IMPLIED, INCLUDING WARRANTIES OF MERCHANTABILITY OR FITNESS FOR A PARTICULAR PURPOSE.**

A unit provided as a replacement will be subject to the warranty of the original unit. The length of the warranty governing the exchanged unit will remain calculated by reference to the purchase date of the original unit.

**This warranty gives you certain legal rights which may change from State to State. Your State may also have other rights you may be entitled to that are not listed within this warranty.**

## Contact Information

[www.green-poweramerica.com](http://www.green-poweramerica.com)

Customer Service

Mon – Fri 8:00 AM – 5:00 PM (EST)

**Toll Free:** 1-877-834-4218

**Service Email:** [service@green-poweramerica.com](mailto:service@green-poweramerica.com)

---

# 5250W Dual Fuel Generator

---

## Specifications

---

### AC electrical

Current Output	16A
Running Watts	4250W(GAS)/3800(Propane)
Starting Watts	5250W(GAS)/4750(Propane)
Outlet	Two 120V 20A NEMA 5-20 Receptacle one 120V/240V 30A NEMA L14-30R Receptacle

### DC electrical

Outlet	12V@8.3A
--------	----------

### Gasoline engine

Type	4-cycle OHV air-cooled recoil start
Displacement	223cc
Oil capacity	20.3floz(0.6L)
EPA approved	yes

### Fuel

Type	Unleaded gasoline
Capacity	4 gallons
Running time	11.5 hours (approx.) on 1/2 load

### Weight

Approximate weight	115lbs.
--------------------	---------

---



## Safety Guidelines – Definitions

This manual contains important information that you need to know and understand in order to protect YOUR SAFETY and to PREVENT EQUIPMENT PROBLEMS. The following symbols help you recognize this information. Please read the manual and pay attention to these sections.

### Save These Important Safety Instructions!

Read and understand all of these safety instructions. Be sure to retain them for future use.



**WARNING! WARNINGS INDICATE A CERTAINTY OR STRONG POSSIBILITY OF PERSONAL INJURY OR DEATH IF INSTRUCTIONS ARE NOT FOLLOWED.**



**CAUTION: CAUTIONS INDICATE A POSSIBILITY OF EQUIPMENT DAMAGE IF INSTRUCTIONS ARE NOT FOLLOWED.**



**NOTE: NOTES GIVE HELPFUL INFORMATION**



**WARNING! IMPROPER OPERATION OR MAINTENANCE OF THIS PRODUCT COULD RESULT IN SERIOUS INJURY AND PROPERTY DAMAGE. READ AND UNDERSTAND ALL WARNINGS AND OPERATING INSTRUCTIONS BEFORE USING THIS EQUIPMENT. WHEN USING AIR TOOLS, BASIC SAFETY PRECAUTIONS SHOULD ALWAYS BE FOLLOWED TO REDUCE THE RISK OF PERSONAL INJURY**

---

# 5250W Dual Fuel Generator

---

## General Precautions



**WARNING! FAILURE TO FOLLOW THESE INSTRUCTIONS CAN RESULT IN SEVERE INJURY**



**CAUTION: FAILURE TO FOLLOW THESE INSTRUCTIONS CAN ALSO RESULT IN DAMAGE TO THE TOOL AND/OR THE ITEM YOU ARE WORKING ON.**

### **DANGER** **CARBON MONOXIDE**



Using a generator indoors **WILL KILL YOU IN MINUTES.**

This generator is equipped with CO-Seizer™ Carbon Monoxide protecting system which will help to protect you in safe. Even so, we still strongly suggest you read the warning contents below to make sure your safety.

Generator exhaust contains high levels of carbon monoxide (CO), a poisonous gas you cannot see or smell. If you can smell the generator exhaust, you are breathing CO. But even if you cannot smell the exhaust, you could be breathing CO.

· NEVER use a generator inside homes, garages, crawlspaces, or other partly enclosed areas.

Deadly levels of carbon monoxide can build up in these areas. Using a fan or opening windows and doors does NOT supply enough fresh air.

· ONLY use a generator outdoors and far away from open windows, doors, and vents. These openings can pull in generator exhaust.

Even when you use a generator correctly, CO may leak into the home. ALWAYS use a battery-powered or battery-backup CO alarm in the home.

If you start to feel sick, dizzy, or weak after the generator has been running, move to fresh air RIGHT AWAY. See a doctor. You could have carbon monoxide poisoning.



**WARNING! THE EXHAUST CONTAINS POISONOUS CARBON MONOXIDE GAS THAT CAN CAUSE LOSS OF CONSCIOUSNESS AND MAY LEAD TO DEATH.**

## Gasoline and Oil

This product requires oil and fuel. Attempting to start the engine without oil will ruin the engine and void the warranty. Work in well ventilated area. Keep cigarettes, flames or sparks away from the work area or where gasoline is stored.



**WARNING! GASOLINE IS EXTREMELY FLAMMABLE AND IS EXPLOSIVE UNDER CERTAIN CONDITIONS. KEEP OUT OF REACH OF CHILDREN.**

- Gasoline fuel and fumes are flammable and potentially explosive. Use proper fuel storage and handling procedures. Always have multiple ABC class fire extinguishers nearby.
- Keep the generator and surrounding area clean at all times.

## General Precautions (cont'd)

### Gasoline and Oil (cont'd)

- Fuel or oil spills must be cleaned up immediately. Dispose of fluids and cleaning materials as per any local, state, or federal codes and regulations. Store oily rags in a covered metal container.
- Never store fuel or other flammable materials near the generator.
- Do not smoke, or allow sparks, flames or other sources of ignition around the engine and fuel tank. Fuel vapors are explosive.
- Keep grounded conductive objects, such as tools, away from exposed, live electrical parts and connections to avoid sparking or arcing. These events could ignite fumes or vapors.
- Do not refill the fuel tank while the engine is running or while the engine is still hot. Do not operate the generator with known leaks in the fuel system.
- Excessive buildup of unburned fuel gases in the exhaust system can create a potentially explosive condition. This buildup can occur after repeated failed start attempts, valve testing, or hot engine shutdown. If this occurs, open exhaust system drain plugs, if equipped, and allow the gases to dissipate before attempting to restart the generator.
- Use only engine manufacturer recommended fuel and oil.

#### Fuel:

Fuel capacity is 4.0 US gallons (15 L). Use regular unleaded gasoline with a minimum octane rating of 90.

#### Oil:

Oil capacity is 20.3fl oz(0.6L)

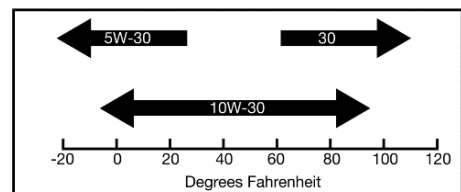

## Hot Components



**WARNING! ENGINE AND EXHAUST SYSTEM PARTS BECOME VERY HOT AND REMAIN HOT FOR SOME TIME AFTER THE ENGINE IS RUN. WEAR INSULATED GLOVES OR WAIT UNTIL THE ENGINE AND EXHAUST SYSTEM HAVE COOLED BEFORE HANDLING THESE PARTS.**

## Power Output

This generator is not designed to power sensitive electronic equipment (including computers and medical devices) without the addition of an approved line conditioner, which is sold separately.



**CAUTION: ATTEMPTING TO POWER SENSITIVE ELECTRONIC EQUIPMENT WITHOUT THE USE OF AN APPROVED LINE CONDITIONER MAY CAUSE DAMAGE TO THE EQUIPMENT. GREEN-POWER LLC IS NOT RESPONSIBLE FOR ANY DIRECT OR INDIRECT DAMAGE CAUSED BY FAILURE TO USE AN APPROVED LINE CONDITIONER.**

---

# 5250W Dual Fuel Generator

---

## General Precautions (cont'd)

### Work Area

- Keep your work area clean and well lit. Cluttered benches and dark areas invite accidents.
- Do not operate power tools in explosive atmospheres, such as in the presence of flammable liquids, gases, or dust. Generators create sparks which may ignite the dust or fumes.
- Keep bystanders, children, and visitors away while operating a generator. Provide barriers or shields as needed.

### Electrical Safety

- Grounded tools must be plugged into an outlet properly installed and grounded in accordance with all codes and ordinances. Never remove the grounding prong or modify the plug in any way. Do not use any adapter plugs.
- Grounding provides a low-resistance path to carry electricity away from the user in the event of an electrical malfunction.
- Double insulated tools are equipped with a polarized plug where one blade is wider than the other. This plug fits in a polarized outlet only one way. If the plug does not fit fully in the outlet, reverse the plug. If it still does not fit, contact a qualified electrician to install a polarized outlet. Do not change the plug in any way. Double insulation eliminates the need for the three-wire grounded power cord and grounded power supply system.
- Avoid body contact with grounded surfaces such as pipes, radiators, ranges, and refrigerators. There is an increased risk of electric shock if your body is grounded.
- Do not expose generator to rain or wet conditions. Water entering a generator will increase the risk of electric shock.
- Do not abuse the power cord. Keep power cords away from heat, oil, sharp edges, or moving parts. Replace damaged power cords immediately. Damaged power cords increase the risk of electric shock.
- When operating a power tool outside, use an outdoor extension cord marked “W-A” or “W”. These extension cords are rated for outdoor use, and reduce the risk of electric shock.



## General Precautions (cont'd)

### Electrical Safety (cont'd)

- All connections and conduits from the generator to the load must only be installed by trained and licensed electricians, and in compliance with all relevant local, state, and federal electrical codes and standards, and other regulations where applicable.
- The generator must be earth-grounded for fixed installations in accordance with all relevant electrical codes and standards before operation.
- Do not attempt to connect or disconnect load connections while standing in water, or on wet or soggy ground.
- Do not touch electrically energized parts of the generator and interconnecting cables or conductors with any part of the body, or with any non-insulated conductive object.
- Connect the generator only to a load or electrical system (120 volt) that is compatible with the electrical characteristics and rated capacities of the generator.
- Before servicing equipment powered by the generator, disconnect the equipment from its power input.
- Keep all electrical equipment clean and dry. Replace any wiring where the insulation is cracked, cut abraded or otherwise degraded. Replace terminals that are worn, discolored, or corroded. Keep terminals clean and tight.
- Insulate all connections and disconnected wires.
- Guard against electric shock. Prevent body contact with grounded surfaces such as pipes, radiators, ranges, and refrigerator enclosures.

### Personal Safety

- Stay alert. Watch what you are doing, and use common sense when operating a generator. Do not use generator while tired or under the influence of drugs, alcohol, or medication. A moment of inattention while operating generators may result in serious personal injury.
- Dress properly. Do not wear loose clothing or jewelry. Contain long hair. Keep your hair, clothing, and gloves away from moving parts. Loose clothes, jewelry, or long hair can be caught in moving parts.

---

# 5250W Dual Fuel Generator

---

## General Precautions (cont'd)

### Personal Safety (cont'd)

- Avoid accidental starting. Make sure the power switch is in its “OFF” position, and disconnect the spark plug wire when not in use.
- Remove adjusting keys or wrenches before turning the generator on. A wrench or a key that is left attached to a rotating part of the generator may result in personal injury.
- Do not overreach. Keep proper footing and balance at all times.
- Use safety equipment. Always wear eye protection. Wear ANSI approved safety impact eye goggles. Dust mask, non-skid safety shoes, hard hat, or hearing protection must be used for appropriate conditions.
- Do not force the generator. Use the correct generator for your application. The correct generator will do the job better and safer at the rate for which it is designed.
- Do not use the generator if the power switch does not turn it on or off. Any generator that cannot be controlled with the power switch is dangerous and must be replaced.

### Generator Use and Care

Make sure the power switch is in its “OFF” position and disconnect the spark plug wire before making any adjustment, changing accessories, or storing the generator. Such preventive safety measures reduce the risk of starting the generator accidentally.

Store idle generators out of reach of children and other untrained persons. Generators are dangerous in the hands of untrained users.

Maintain generators with care. Do not use damaged generator. Tag damaged generators “Do not use” until repaired.

Check for misalignment or binding of moving parts, breakage of parts, and any other condition that may affect the generator’s operation. If damaged, have the generator serviced before using. Many accidents are caused by poorly maintained generators.

Use only accessories that are recommended by the manufacturer for your model. Accessories that may be suitable for one generator may become hazardous when used on another generator.

## General Precautions (cont'd)

### Servicing

Maintain labels and name plates on the generator and engine. These carry important information. If unreadable or missing, contact our service center toll free immediately for a replacement.

Generator service must be performed only qualified repair personnel. Service or maintenance performed by unqualified personnel could result in a risk of injury.

When servicing a generator, use only identical replacement parts. Follow all appropriate instructions in this manual. Use of unauthorized parts or failure to follow maintenance instructions may create a risk of electric shock or injury.

### Heart Pacemakers



**WARNING! PEOPLE WITH PACEMAKERS SHOULD CONSULT THEIR PHYSICIAN(S) BEFORE USING THIS PRODUCT. ELECTROMAGNETIC FIELDS IN CLOSE PROXIMITY TO A HEART PACEMAKER COULD CAUSE INTERFERENCE TO OR FAILURE OF THE PACEMAKER.**

### Installation

- If a transfer switch is installed, ensure installation meets all applicable safety, and local and national electrical codes. Have installation performed by a qualified, licensed electrician and building contractor.
- All electrical work, including the earth-ground connection, should be completed by a licensed electrician.
- Any separate fuel storage or generator supply facility must be built or installed in full compliance with all relevant local, state, and federal regulations.

---

# 5250W Dual Fuel Generator

---

## General Precautions (cont'd)

### Installation (cont'd)

- If the generator is installed outdoors, it must be weatherproofed and should be soundproofed. It should not be run outdoors without protection to the generator and wiring conduit.
- The generator might weigh over 100 lbs. Two or more people should assist when moving or lifting this product. Never lift the generator using the engine or alternator lifting lugs. Connect lifting equipment to the frame of the generator.
- Before lifting the generator, ensure the lift rigging and supporting structure are in good condition, and are rated to lift such a load.
- Keep all personnel away from the suspended generator during relocating.
- The supporting floor/ground surface should be level and strong enough to safely hold the weight of the generator. If the floor/grounded surface is not level, strong cross members should be placed under the full length of the generator frame at its low side.
- For trailer installation, the generator should be mounted on the center point of the trailer, over the wheels. The trailer must be capable of supporting the weight of the generator and all contents (tools, etc.)
- Install sound-and weather-proofing only when it is not raining or snowing to avoid trapping moisture within the generator's area.

### Mechanical

- Always make sure the power switch is in its "OFF" position. Disconnect the spark plug wire, and allow the engine to completely cool before carrying out maintenance.
- Check for damaged parts. Before using the generator, any part that appears damaged should be carefully checked to determine that it will operate properly and perform its intended function. Check for alignment and binding of moving parts, any broken parts or mounting fixtures, and any other condition that may affect proper operation technician.
- The generator is designed with guards for protection from moving parts. In any case, care must still be taken to protect personnel and equipment from other mechanical hazards when working around the generator.



## General Precautions (cont'd)

### Mechanical (cont'd)

- Do not operate the generator with safety guards removed. While the generator is running, do not attempt to reach around the safety guard for maintenance or any other reason.
- Keep hands, arms, long hair, loose clothing, and jewelry away from moving parts. Be aware that when engine parts are moving fast they cannot be seen clearly.
- Keep access doors on enclosures closed and locked when access is not required.
- When working on or around the generator always wear protective clothing including ANSI approved safety gloves, safety eye goggles, and safety hat.
- Do not alter or adjust any part of the generator that is assembled and supplied by the manufacturer.
- Always follow and complete scheduled engine and generator maintenance.

### Chemicals

- Avoid contact with hot fuel, oil, exhaust fumes, and hot solid surfaces.
- Avoid body contact with fuels, oils, and lubricants used in the generator. If swallowed, seek medical treatment immediately. Do not induce vomiting if fuel is swallowed. For skin contact, immediately wash with soap and water. For eye contact, immediately flush eyes with clean water and seek medical attention.

### Noise

- Prolonged exposure to noise levels above 68 DBA is hazardous to hearing. Always wear ANSI approved ear protection when operating or working around the generator when it is running.

---

# 5250W Dual Fuel Generator

---

## General Precautions (cont'd)

### Extension Cord

If an extension cord (not included) is used, make sure to use only UL approved cords having the correct gauge and length according to the following table:

#### Nameplate Amps (@ full load)

#### Cord Lengths

	0 ft.- 50 ft.	50 ft.-100 ft.	100 ft.-150 ft.	150 ft.-200 ft.
0 - 5	16 AWG	16 AWG	12 AWG	12 AWG
5.1 - 8	16 AWG	14 AWG	10 AWG	-
8.1 - 12	14 AWG	12 AWG	-	-
12.1 - 15	12 AWG	10 AWG	-	-
15 - 20	10 AWG	10 AWG	-	-

## Assembly and Installation

### Unpacking

1. Remove the generator and loose parts box from the carton.
2. Compare the Hardware Kit included with the inventory list below.

### Loose Parts (Wheel kit and handle)

Check all loose parts against the following list. Contact your dealer toll free at 877.834.4218, if any of the parts listed below is/are not found.

### Hardware Check:

Your wheel should include:

- 1) Two Handles with bolts, R pin
- 2) Two axle shaft with nuts.
- 3) Two Split Pin
- 4) One generator leg with bolts and nuts
- 5) Two wheels

### Install the Handles

- a. Install the handle through the frame and assure two holes are alignment (Fig 1)
- b. Install the pan head pin through the handle and frame (Fig 2)
- c. Install R pin through pan head pin to lock it in place (Fig 3)

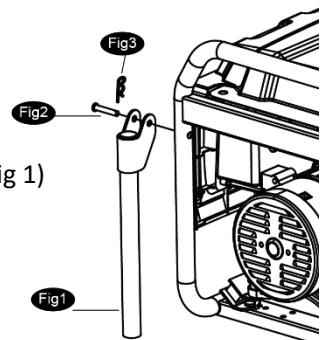

### Install Feet to Frame

- a. Place the mounting feet at the bottom of frame and assure that four holes are alignment , and then Install the mounting feet to the frame using four bolts and nuts (Fig 4)

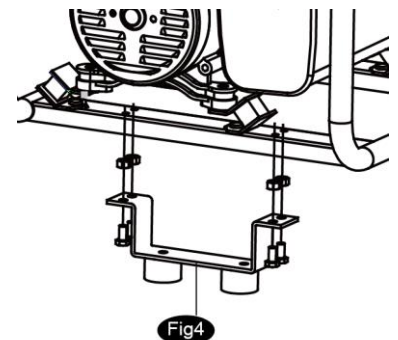

### Install Wheels

- a. Install the axle pin (the long end) through the wheel (Fig 5)
- b. Install the big washer outside the wheel(Fig 6)
- c. Insert the cotter pin through the washer and wheel (Fig 7)
- d. Install the wheel with axle pin through the axle bracket on the frame(Fig 8)
- e. Install the hairpin cotter through the axle pin to lock it in place (Fig 9)

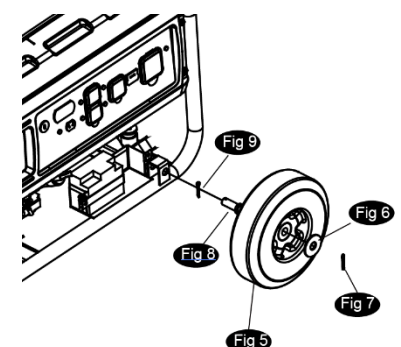

---

# 5250W Dual Fuel Generator

---

## Installation



**NOTE: PRIOR TO POWERING TOOLS AND EQUIPMENT MAKE SURE THE GENERATOR'S RATED VOLTAGE, WATTAGE AND AMPERAGE CAPACITY IS ADEQUATE TO SUPPLY ALL ELECTRICAL LOADS THAT THE UNIT WILL POWER. IF POWERING EXCEEDS THE GENERATOR'S CAPACITY, IT MAY BE NECESSARY TO GROUP ONE OR MORE OF THE TOOLS AND/OR EQUIPMENT FOR CONNECTION TO A SEPARATE GENERATOR.**

Electrical and other permits may be required for the installation of emergency power systems. Investigate your local building and electrical codes before installing this unit. Installation must be completed by licensed contractors.



**WARNING! THE GENERATOR WEIGHS APPROXIMATELY OVER 100 POUNDS. USE CARE AND THE PROPER LIFTING OR HOISTING EQUIPMENT WHEN MOVING IT TO THE INSTALLATION LOCATION. ALWAYS CONNECT HOIST LINES TO THE FRAME OF THE GENERATOR.**

## General Location

- Make sure to locate and install the generator outdoors where cooling air is readily available.
- Install the generator so that the air inlets and outlets are not blocked by obstructions such as bushes, trees, or snow drifts. Locating it in the path of heavy winds or snowdrifts may require the placement of a barrier for protection. In normal weather conditions, the air vent should face the prevailing wind direction.
- Install the generator on a concrete slab or other area where rain drainage or flood waters can not reach it.
- Generator placement should allow four feet of access to all sides for maintenance.
- Place the generator as close as possible to the electrical tools and equipment being powered to reduce the length of extension cords.

## Installation (cont'd)

### Supporting and Mounting

Mount the generator on a concrete slab capable of supporting the weight of the generator. The slab must extend on all sides beyond the frame by at least one foot. Contact a cement contractor for slab specifications if necessary. Attach the frame to the concrete slab using 3/8" diameter expansion anchor bolts (not supplied).

### Grounding



**NOTE: IT IS RECOMMENDED THAT ONLY A TRAINED AND LICENSED ELECTRICIAN PERFORM THIS PROCEDURE**

Connect a #6 AWG grounding wire (not included) from the ground connector (8) on the generator to a grounding rod (not included) that has been driven at least 24 inches deep into the earth. The grounding rod must be an earth-driven copper or brass rod (electrode) which can adequately ground the generator.

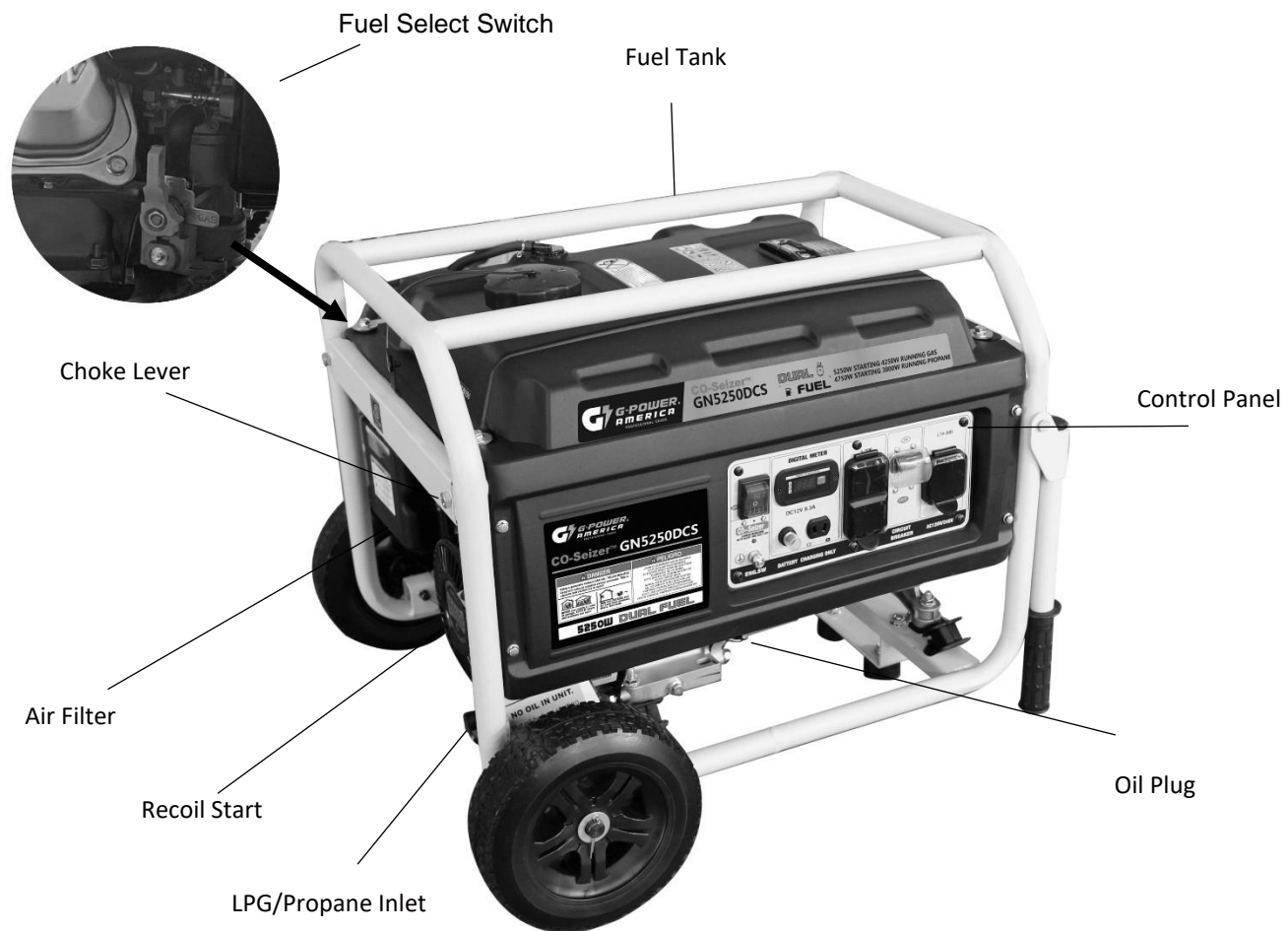

---

# 5250W Dual Fuel Generator

---

## Operation



**NOTE: THE PARTS LISTED ABOVE ARE HELPFUL FOR LOCATING THE CONTROLS MENTIONED BELOW**

### Before Starting the Generator



**CAUTION: PRIOR TO FIRST USING THE GENERATOR, THE ENGINE MUST BE FILLED WITH HIGH QUALITY SAE 10W-30 GRADE ENGINE OIL. TO DO SO, UNSCREW AND REMOVE THE ENGINE'S OIL DIPSTICK LOCATED AT THE BOTTOM OF THE ENGINE CRANKCASE. FILL THE ENGINE CRANKCASE UNTIL THE OIL LEVEL IS LEVEL WITH THE UPPER MARKED LINE ON THE DIPSTICK. THEN SCREW THE DIPSTICK BACK INTO THE OIL FILL HOLE.**

Filling the Fuel Tank – Follow the steps below to fill the fuel tank:

1. Check that the engine power switch is in its "OFF" position.
2. Before the first use, remove the fuel tank cap and fill the fuel tank with unleaded gasoline. When fueling, be sure that the fuel strainer is in place. Replace the fuel tank cap. Thereafter, check the engine's fuel gauge for the amount of unleaded gasoline in the fuel tank. If necessary, refill the fuel tank with unleaded gasoline; the generator must be turned off and cooled down before refilling the fuel tank.

Connecting the LPG/Propane tank

1. Make sure the generator is off, on a flat surface in well ventilated area.
2. Make sure propane tank valve is in the off position.
3. Make sure the fuel selector switch to "Propane".
4. Remove the plastic cover on the generator propane inlet valve.
5. Use your fingers to tighten the LPG hose (included) end below to the generator propane inlet. **DO NOT OVER-TIGHTEN 35-88 lb-in maximum.**

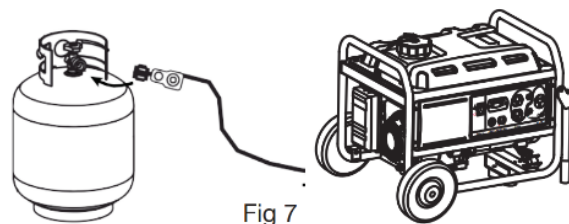

6. Attach the other end of the hose to a tank of LPG/Propane and hand tighten.
7. Check all connections for leaks by wetting the fittings with soapy water. Anywhere that bubbles appear or grow indicates a leak in the connection. If a leak exists at a fitting then turn off the tank valve and tighten the fitting. Turn the gas back on and recheck with soapy water again. If the leak continues or if the leak is not at a fitting then do not use the generator and contact customer service.

## Operation(cont'd)

### Starting

#### 1. Select Fuel Source:

#### FOR GASOLINE:

- a. Switch the gasoline valve to ON position (Fig 8)
- b. Turn the Fuel Select Switch point to GAS (Fig 9)

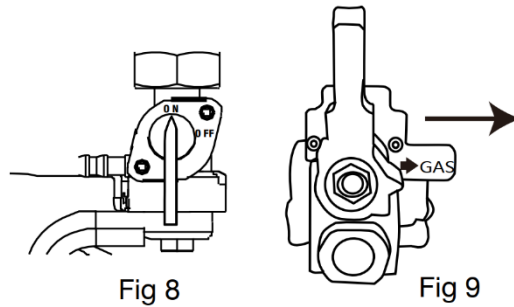

#### FOR LPG/PROPANE:

- a. Make sure the LPG hose is safely secured from the generator to the tank.
- b. Switch the gasoline valve to OFF position(Fig 10)
- c. Turn the Fuel Select Switch point to LPG(Fig 11)
- d. Fully open the propane tank valve. (Fig 12)

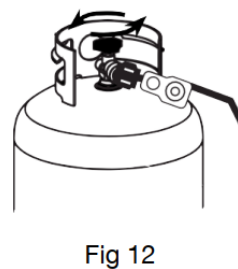
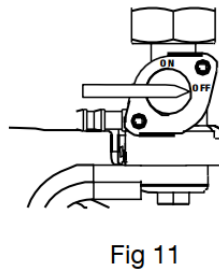
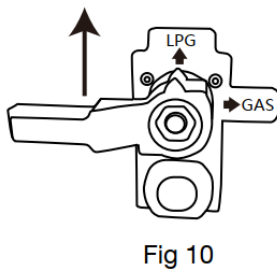

2. Turn the engine switch to the ON position. (Fig 13)

The engine switch enables and disables the ignition system.

OFF: To stop the engine

ON: To run the engine

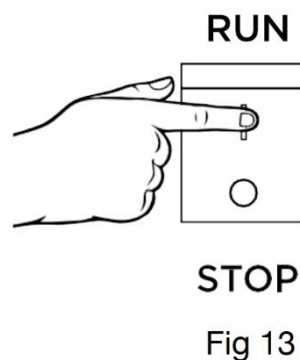

---

# 5250W Dual Fuel Generator

---

## Operation (cont'd)

### STOPPING THE GENERATOR

1. Remove all connections from the control panel receptacles
2. Allow the generator to run at “no load” to reduce and stabilize engine and alternator temperatures.
3. If you operate with gas, switch the gasoline valve to OFF position(Fig 11); Or if you operate with propane, shut –off the propane tank valve(Fig 14).
4. Push the generator "STOP" button to stop the engine;

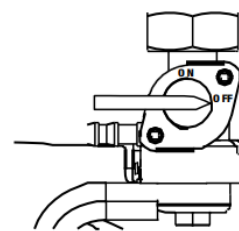

Fig 11



Fig 14



Fig 15

#### During an Emergency

If there is an emergency and the generator must be stopped quickly, position the engine control switch to the STOP position immediately.



## Operation (cont'd)

### Powering 120/240 Volt AC Tools And Equipment:

1. Prior to powering tools and equipment, make sure the generator's rated voltage, and amperage capacity is adequate to supply all electrical loads that the unit will power. If total demanding power exceeds the generator's capacity, it is necessary to remove one or more of the tools and/or equipment to another generator.



**CAUTION: ATTEMPTING TO POWER SENSITIVE ELECTRONIC EQUIPMENT SUCH AS LAPTOPS WITHOUT THE USE OF AN APPROVED LINE CONDITIONER MAY CAUSE DAMAGE TO THE EQUIPMENT. GREEN-POWER LLC IS NOT RESPONSIBLE FOR ANY DIRECT OR INDIRECT DAMAGE CAUSED BY FAILURE TO USE AN APPROVED LINE CONDITIONER.**

2. Once the generator is running, simply connect the power cords of 120/240volt AC powered tools and equipment into the 120/240volt AC dual outlets.



**NOTE: THE GENERATOR FEATURES AN AC NON-FUSE THERMAL PROTECTOR TO PROTECT THE AC CIRCUIT IN CASE OF AN OVERLOAD. SHOULD AN OVERLOAD OCCUR, THE BREAKER WILL POP.**

3. Disconnect all electrical powered tools and equipment from the generator's 120/240volt AC dual outlets.
4. After the engine and generator have completely cooled, store generator in a safe, clean, dry location (if not already installed).

---

# 5250W Dual Fuel Generator

---

## Operation (cont'd)

### Powering 12 Volt DC tools and Equipment:

1. Prior to powering tools and equipment, make sure the generator's rated voltage, and amperage capacity (12V DC) is adequate to supply all electrical loads that the unit will power. If powering exceeds the generator's capacity, it may be necessary to group one or more of the tools and/or equipment for connection to a separate generator.
2. Connect the power cord of a 12 VDC powered tool or equipment to the DC Terminals.



**CAUTION: MAKE SURE TO CONNECT THE POSITIVE (+) LEAD OF THE POWER CORD TO THE POSITIVE (+) TERMINAL ON THE GENERATOR, AND CONNECT THE NEGATIVE (-) LEAD OF THE POWER CORD TO THE NEGATIVE (-) TERMINAL ON THE GENERATOR.**

**THE 12V DC IS FOR BATTERY CHARGING ONLY.**

## Inspection, Cleaning, and Maintenance



**WARNING! ALWAYS MAKE SURE THE ENGINE POWER SWITCH IS IN ITS "OFF" POSITION. DISCONNECT THE SPARK PLUG WIRE FROM THE ENGINE. AND ALLOW SUFFICIENT TIME FOR THE ENGINE AND GENERATOR TO COMPLETELY COOL BEFORE PERFORMING ANY INSPECTIONS, MAINTENANCE, OR CLEANING.**

### Spark Plug Maintenance

In order to service the spark plug, you will need a spark plug wrench (commercially available). Recommended spark plugs TORCH F6RTC but we recommend our OEM spark plug.

To ensure proper engine operation, the spark plug must be properly gapped and free of deposits.

1. Remove the spark plug cap.
2. Clean any dirt from around the spark plug base.
3. Use a spark plug wrench to remove the spark plug. ( Fig 15 )

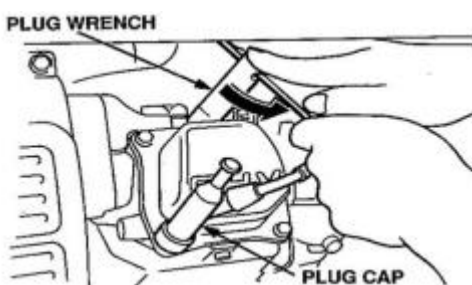

( Fig 15 )

4. Visually inspect the spark plug. Discard it if the insulator is cracked or chipped. Clean the spark plug with a wire brush if it is to be reused.
5. Measure the plug gap with a feeler gauge. (Correct as necessary by carefully bending the side electrode.) The gap should be: 0.70-0.80 mm (0.028-0.031in) ( Fig 16 )

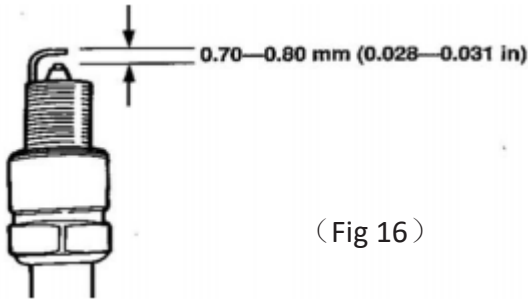

( Fig 16 )

6. Check that the spark plug washer is in good condition.
7. After the spark plug is seated, tighten with a spark plug in by hand to prevent cross-threading.
8. After the spark plug is seated, tighten with a spark plug wrench to compress the washer



**NOTE: THE SPARK PLUG MUST BE SECURELY TIGHTENED. AN IMPROPERLY TIGHTENED SPARK PLUG CAN BECOME VERY HOT AND COULD DAMAGE THE ENGINE. NEVER USE SPARK PLUGS WHICH HAVE AN IMPROPER HEAT RANGE. USE ONLY RECOMMENDED SPARK PLUS OR EQUIVALENT.**

## Maintenance Guide

Periodic maintenance and adjustment is necessary to keep the generator in good operating condition.

**WARNING! Exhaust gas contains poisonous carbon monoxide. Shut off the engine before performing any maintenance. If the engine must be run, make sure the areas is well ventilated.**

Before each use, inspect the generator. Check for:

- Loose screws
  - Misaligned or binding moving parts
  - Cracked or broken parts
  - Damaged electrical wiring
  - Any other condition that may affect safe operation.
- If an engine problem occurs, have it checked by a qualified service technician before further use.
- Do not use damaged equipment.

---

# 5250W Dual Fuel Generator

---

- Before each use, make sure the engine's oil and gas levels are adequate. If necessary, fill the crankcase until the oil level is even with the oil fill hole and/or fill the fuel tank.
- Before each use, remove all debris with a soft brush, rag, or vacuum.
- Lubricate all moving parts using a premium quality, lightweight machine oil.
- Every 50 hours of use, drain the old engine oil and replace with a high quality SAE 10W-30 grade engine oil.
- Every 300 hours of use, have a qualified, certified technician perform thorough maintenance on the generator and engine.
- For long term storage, either drain fuel into suitable container or add a fuel preservative/stabilizer (not included) to prevent fuel breakdown.

## Maintenance Guide

A dirty air cleaner will restrict air flow to the carburetor, lower generator output power and deteriorate the engine emission. To prevent carburetor malfunction, service the air cleaner regularly. Service more frequently when operating the generator in extremely dusty areas.



**WARNING!** Using gasoline or flammable solvent to clean the filter element can cause a fire or explosion. Use only soapy water or nonflammable solvent.



**NOTE:** Never run the generator without the air cleaner. Rapid engine wear will result.

1. Unsnap the air cleaner cover clips, remove the air cleaner cover, and remove the air filter.
2. Wash the element in a solution of household detergent and warm water, then rinse thoroughly, or wash in nonflammable or high flash point solvent. Allow the element to dry thoroughly.

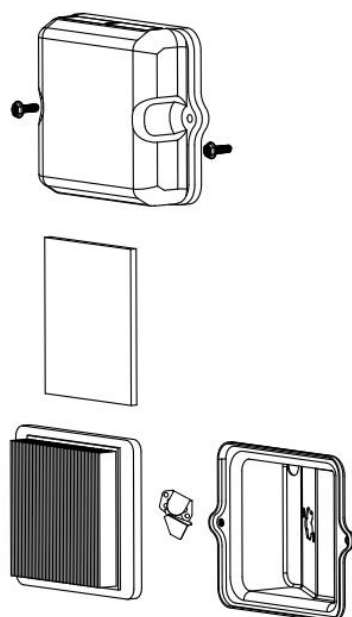

3. Soak the element in clean engine oil and squeeze out the excess oil. The engine will smoke during initial start-up if too much oil is left in the element.

4. Reinstall the air cleaner element and the cover

## Transporting/Storage

When transporting the generator, turn the engine switch and the fuel valve OFF. Keep the generator level to prevent fuel spillage. Fuel vapor or spilled fuel may ignite.



**WARNING!** Contact with a hot engine or exhaust system can cause serious burns or fires. Let the engine cool before transporting or storing the generator.

Take care not to drop or strike the generator when transporting. Do not place heavy objects on the generator.

Before storing the unit for an extended period:

1. Be sure the storage area is free of excessive humidity and dust.
2. Service according to the table below:

<b>STORAGE TIME</b>	<b>RECOMMENDED SERVICE PROCEDURE TO PREVENT HARD STARTING</b>
Less than 1 month	No preparation required
1 to 2 months	Fill with fresh gasoline and add gasoline conditioner*.
2 months to 1 year	Fill with fresh gasoline and add gasoline conditioner*. Drain the carburetor float bowl. Drain the fuel sediment cup.

# 5250W Dual Fuel Generator

1 year or more	Fill with fresh gasoline and add gasoline conditioner*. Drain the carburetor float bowl. Drain the fuel sediment cup. Remove the spark plug. Put a tablespoon of engine oil into the cylinder. Turn the engine slowly with the pull rope to distribute the oil. Reinstall the spark plug. Change the engine oil. After removal from storage, drain the stored gasoline into a suitable container, and fill with fresh gasoline before starting.
----------------	--

## Transporting/Storage

1. Drain the carburetor by loosening the drain screw. Drain the gasoline into a suitable container.(017)

### **⚠ WARNING**

Gasoline is extremely flammable and is explosive under certain condition Perform this task in a well ventilated area with the engine stopped. Do not smoke or allow flames or sparks in the area during this procedure.

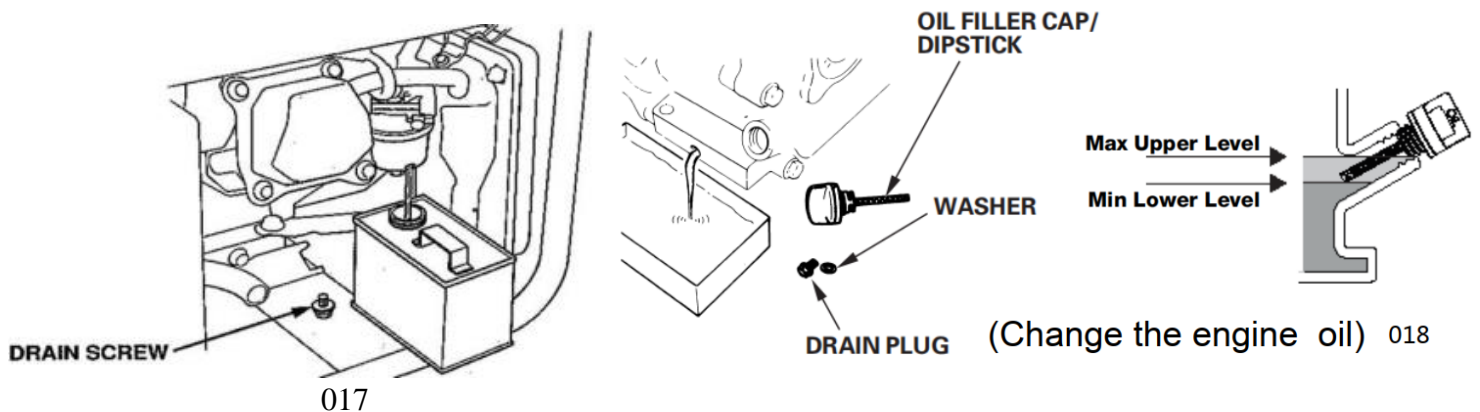

2. Change the engine oil.

2.1 Drain the used oil while the engine is warm. Warm oil drains quickly and completely. Avoid contact with hot oil.(018)

2.2 Place a suitable container below the engine to catch the used oil then remove the filler cap/dipstick and the drain plug. Allow the used oil to drain completely, then reinstall the drain plug, and tighten it securely.

2.3 With the engine in a level position, fill to the outer edge of the oil filler hole with the recommended oil. Securely screw in the filler cap/dipstick.

3. Remove the spark plug, and pour about a tablespoon of clean engine oil into the cylinder. Crank the engine several revolutions to distribute the oil, then reinstall the spark plug.
4. Slowly pull the starter grip until resistance is felt. At this point, the piston is coming up on its compression stroke and both the intake and exhaust valves are closed. Storing the engine in this position will help to protect it from internal corrosion.(019)

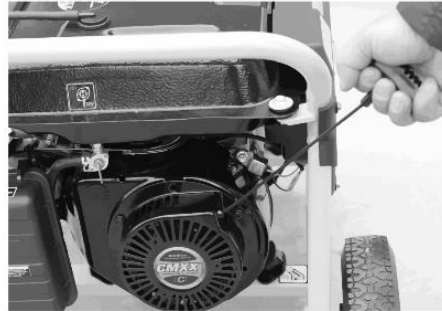

019

---

# 5250W Dual Fuel Generator

---

## CO-Seizer™ CARBON MONOXIDE PROTECTING SYSTEM

### **DANGER!** TO PREVENT SERIOUS INJURY AND DEATH FROM

#### CARBON MONOXIDE INHALATION:

The Carbon Monoxide sensor is an additional layer of protection only. Do not use the Generator in any area or situation that will allow carbon monoxide to accumulate.

- **FLASHING RED LIGHT:**

Dangerous levels of carbon monoxide gas have built up and generator will shut off automatically. Leave immediately until area has aired out. Move generator to well-ventilated area before operation.

- **FLASHING ORANGE LIGHT:**

Carbon monoxide sensor malfunctions. Sensor needs service. Do not use the Generator until the sensor is working properly. For technical questions, please call 1-877-834-4218.

**Carbon Monoxide sensor must only be serviced by qualified technician to restore it to original settings. Do not modify or tamper with the Carbon Monoxide sensor. Not following these instructions can result in death or serious injury due to Carbon Monoxide sensor malfunction.**

### CO seizer alarm status

1. When the carbon monoxide concentration reaches a dangerous level, the CO seizer will trigger stop signal. The generator will shutoff and the indicator light will flash red for 5 minutes.

Solutions: Leave immediately until area has aired out to reduce CO concentration and ensure users' safety

2. When the DC output circuit is short-circuited, the CO seizer will trigger stop signal. The generator will shutoff and the indicator light will flash orange for 5 minutes.

Solutions: 1、 Check whether there is a short circuit 2、 Check whether the DC circuit breaker is disconnected. As that happens, please press the button to reset.



General Parts Listing

GN5250DCS

Bl	Black	Br	Brown	Y/G	Yellow/Green
O	Orange	Br/R	Brown/Red	B/W	Black/White
Bu	Blue	LB	Light Blue	G	Green
Gr	Gray	Bl	Black	P	Pink
R	Red	W	White		

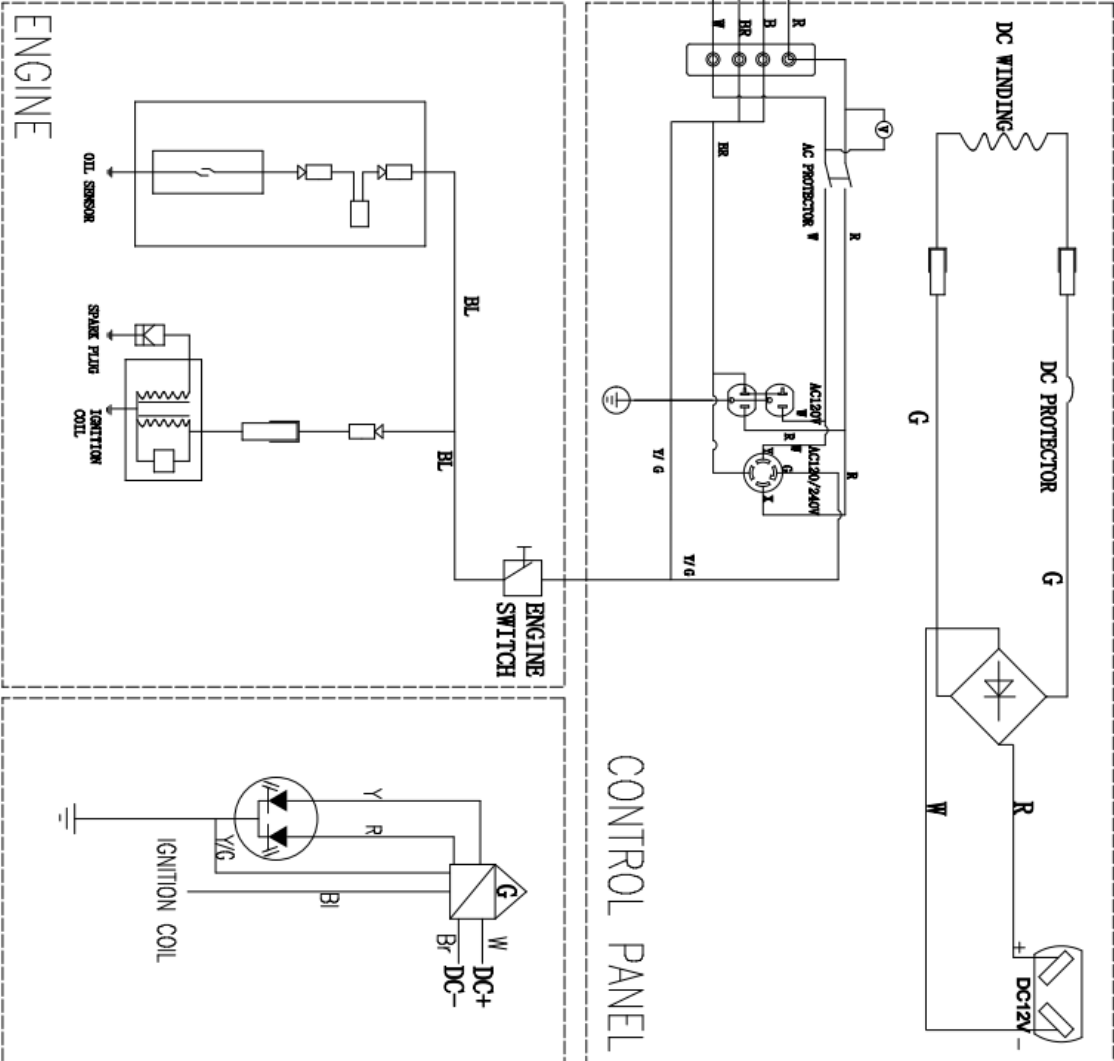
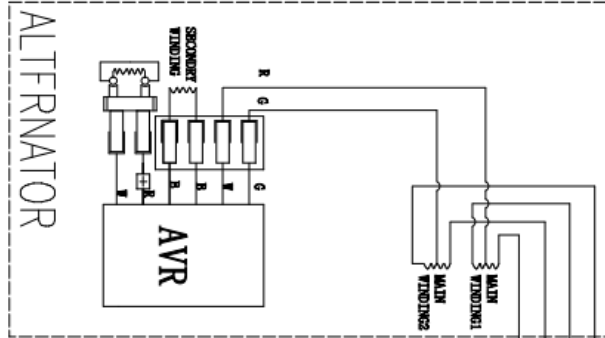

# 5250W Dual Fuel Generator

cylinder head system assy.

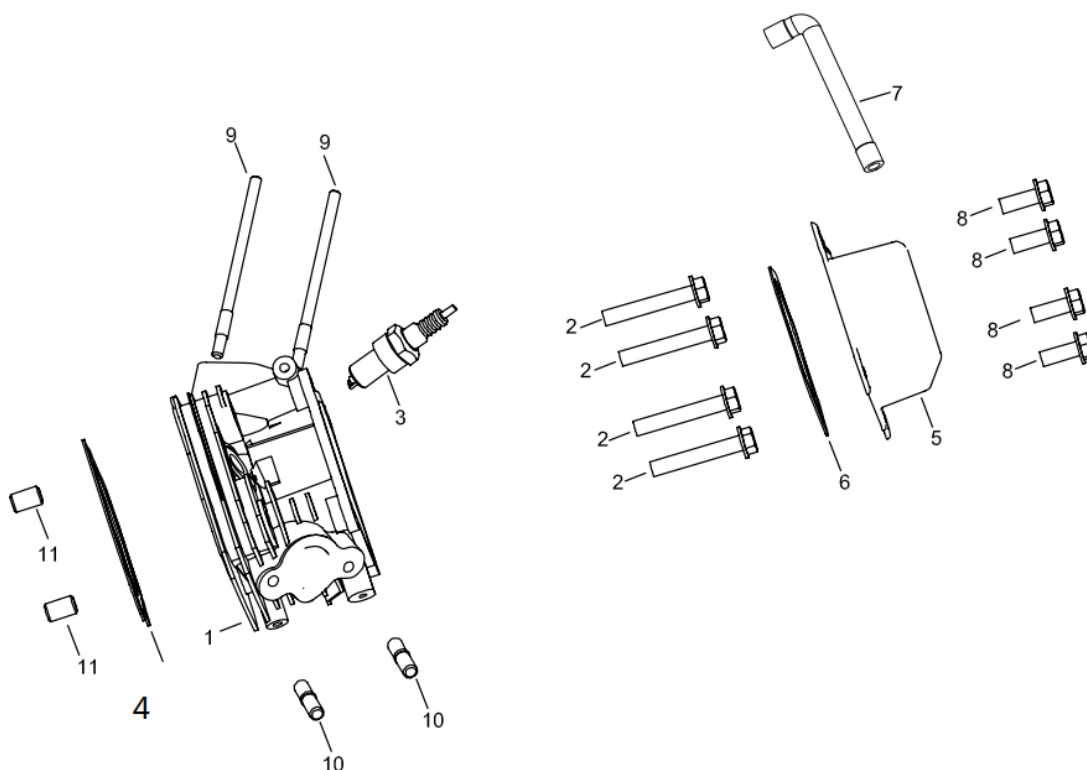

**A**

GPA Parts No	Parts No.	Description	Qty
GPG4000-A-01	BGH40025	CYLINDER HEAD COMP.	1
GPG4000-A-02	PGH49028	FLANGE BOLT (M8X58)	4
GPG4000-A-03	PGH44726	SPARK PLUG	1
GPG4000-A-04	PGH40075	CYLINDER HEAD SEALING PAD	1
GPG4000-A-05	PGHA0650	HEAD COVER COMP.	1
GPG4000-A-06	PGHA0675	HEAD COVER PACKING	1
GPG4000-A-07	PGH40779	TUBE	1
GPG4000-A-08	PGS40003	HEX HEAD FLANGE BOLT M6X12	4
GPG4000-A-09	PGH44176	CARBUR ETOR STUD BOLT	2
GPG4000-A-10	PGH42950	EXHAU ST PIPE STUD BOLT	2
GPG4000-A-11	PGH41025	DOWEL PIN (10X16)	2

## Cylinder barrel assy.

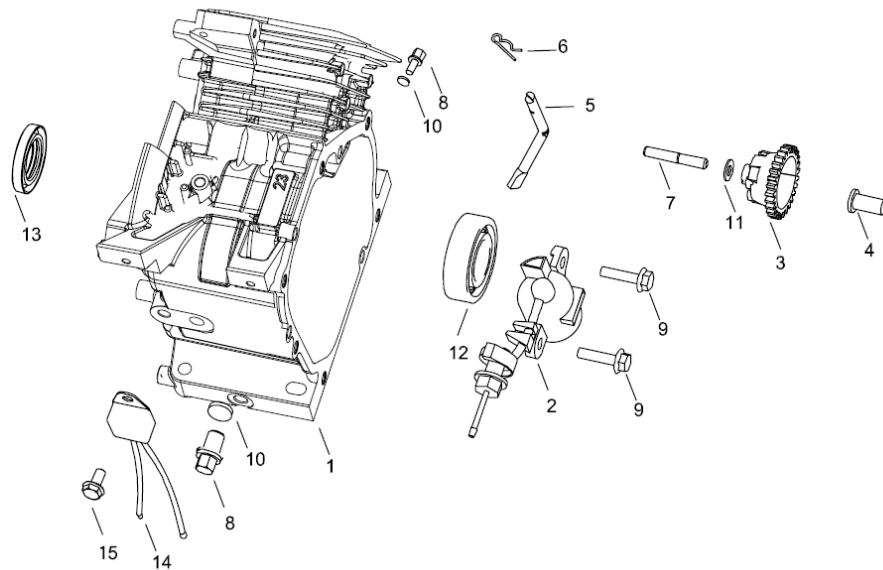

## B

GPA Parts No	Parts No.	Description	Qty
GPD5000-B-01	PGH48101	CYLINDER HEAD COMP.	1
GPD5000-B-02	PGH44760	OIL LEVEL SWITCH ASSY.	1
GPD4000-B-03	PGH45125	GOVERNOR GEAR ASSY.	1
GPD4000-B-04	PGH45150	GOVERNOR SLIDER	1
GPD4000-B-05	PGH45650	GOVERNOR ARM SHAFT	1
GPD4000-B-07	PGH45200	SLIDER SHAFT	1
GPD4000-B-08	PGH40975	DRAIN PLUG BOLT	2
GPD4000-B-09	PGS40006	HEX HEAD FLANGE BOLT M6X16	2
GPD4000-B-10	PGH40951	DRAIN PLUG WASHER (10.2mm)	2
GPD4000-B-11	PGH45225	SLIDER WASHER	1
GPD4000-B-12	PGH42133	BALL BEARING (6205)	1
GPD4000-B-13	PGH40925	OIL SEAL( $\phi 25 \times \phi 41.25 \times 6$ )	1
GPD4000-B-14	PGH44775	OIL ALERT	1
GPD4000-B-15	PGS40003	HEX HEAD FLANGE BOLT M6X12	1

# 5250W Dual Fuel Generator

Crankcase cover system assy.

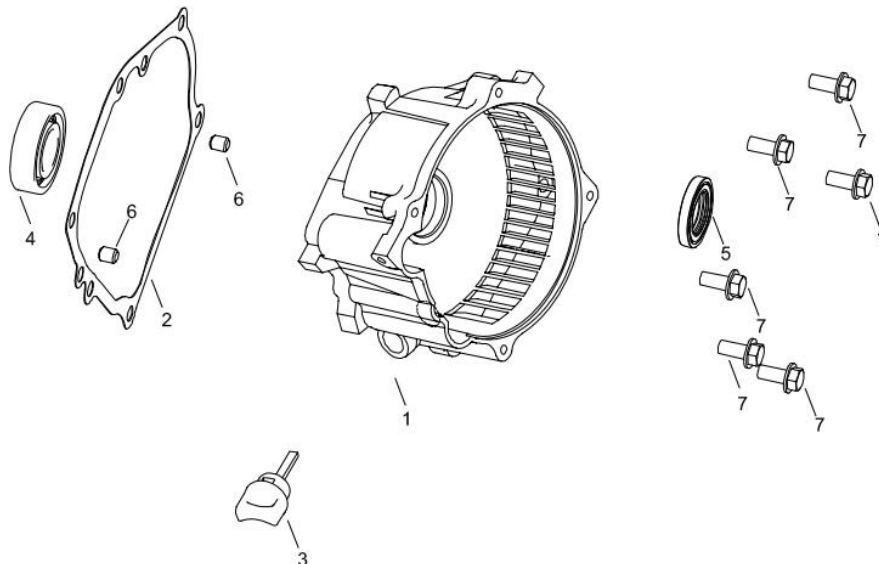

**C**

GPA Parts No	Parts No.	Description	Qty
GPG4000-C-01	PGH46854	CRANK CASE COV ER	1
GPG4000-C-02	PGH46934	CRANK CASE COV ER PAD	1
GPG4000-C-03	PGH46902	OIL SCALE	1
GPG4000-C-04	PGH42133	BALL BEARING(6205)	1
GPG4000-C-05	PGH40925	OIL SEAL( $\phi 25 \times \phi 41.25 \times 6$ )	1
GPG4000-C-06	PGH41000	DOWEL PIN (8×14)	2
GPG4000-C-07	PGH46875	FLANGE BOLT(M8×28)	6

**Crankshaft system assy.**

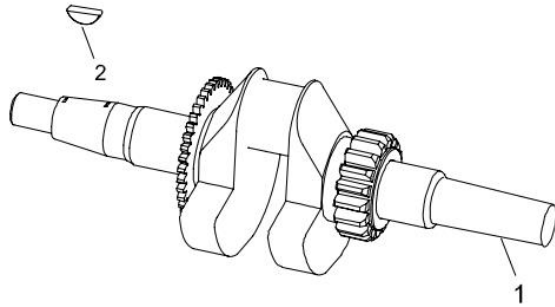

**D**

GPA Parts No	Parts No.	Description	Qty
GPG5000-D-01	PGH48211	CRANKSHAFT COMP.	1
GPG4000-D-02	PGH48211-1	SEMICIRCLE KEY	1

# 5250W Dual Fuel Generator

Piston and connecting rod system assy.

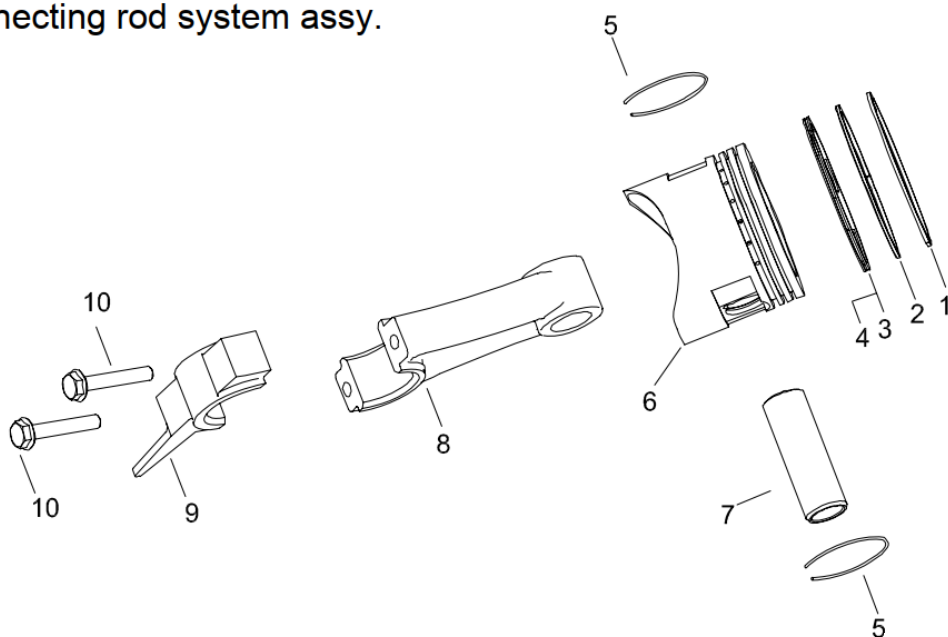

**E**

GPA Parts No.	Parts No.	Description	Qty
GPG4000-E-01	PGH41327-1	COMPRESSION RING A	1
GPG4000-E-02	PGH41327-2	COMPRESSION RING B	1
GPG4000-E-03	PGH41327-3	OIL RING A	2
GPG4000-E-04	PGH41327-4	OIL RING B	1
GPG4000-E-05	PGH41300	PISTON PIN CLIP	2
GPG4000-E-06	PGH41253	PISTON	1
GPG4000-E-07	PGH41275	PISTON PIN	1
GPD5000-E-08	PGH48171-1	CONNECTING ROD	1
GPD5000-E-09	PGH48171-2	CONNECTING COVER	1
GPD5000-E-10	PGH48171-3	CONNECTING ROD BOLT	2

## Valve Train Assembly

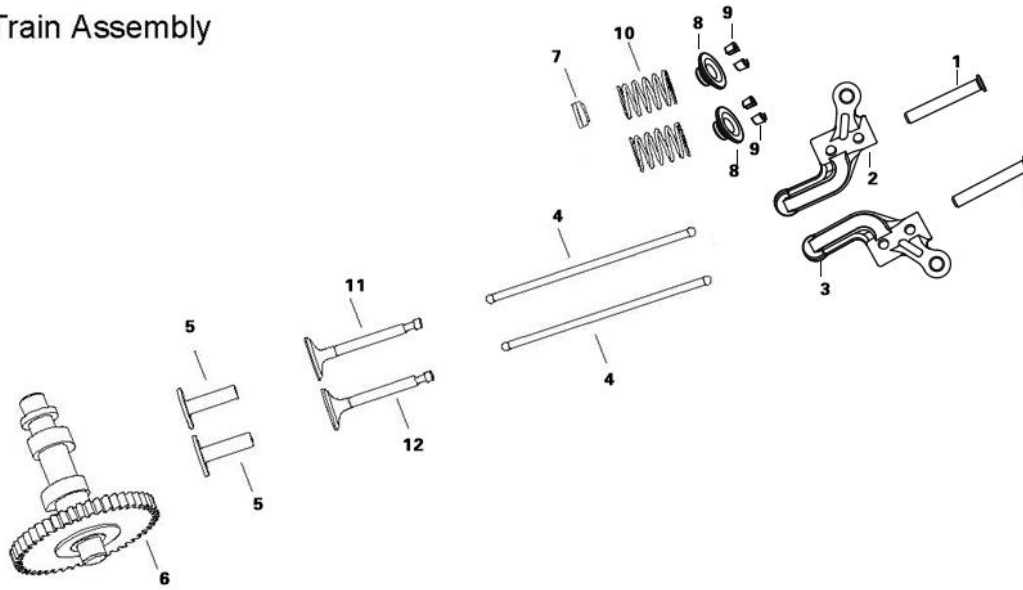

## F

GPA Parts No.	Parts No.	Description	Qty
GPG4000-F-01	PGHA0475	ROCKER ARM PIN	2
GPG4000-F-02	PGHA0500	IN TAKE ROCKER ARM	2
GPG4000-F-03	PGHA0515	EXHAUST ROCKER ARM	2
GPG5000-F-04	PGH49035	PUSH ROD	2
GPG4000-F-05	PGH40325	VALVE LIFTER	2
GPD5000-F-06	PGH41902	CAMSHAFT	1
GPG4000-F-07	PGH40300	OIL SEAL	1
GPG4000-F-08	PGHA0150	I N . VALVE SPRING RETAINER	2
GPG4000-F-09	PGHA0175	VALVE COLLET	4
GPG4000-F-10	PGHA0100	VALVE SPRING	2
GPG4000-F-11	PGHA0125	EX. VALVE	1
GPG4000-F-12	PGHA0225	IN. VALVE	1

# 5250W Dual Fuel Generator

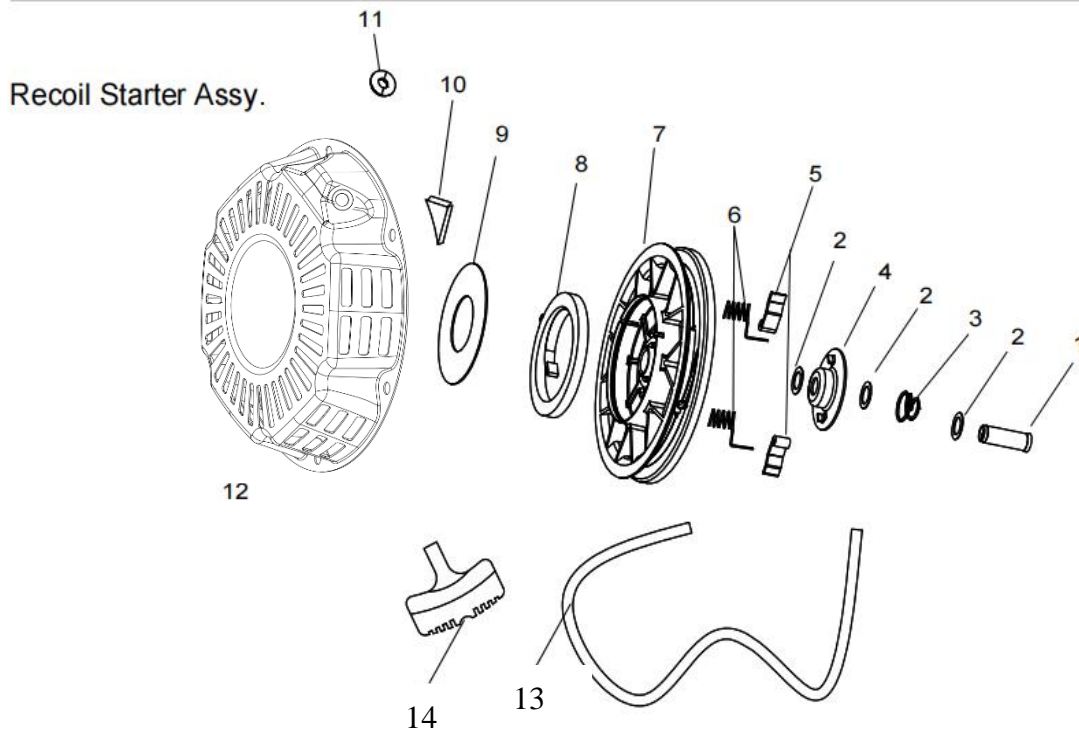

G

GPA Parts No.	Parts No.	Description	Qty
GN5250-G-01	BGH76022.1.1	ELASTIC CYLINDRICAL PIN1	1
GN5250-G-02	BGH76076.1.2	WASHER $\varnothing$ 10	3
GN5250-G-03	BGH76076.1.3	PRESSURE SPRING	1
GN5250-G-04	BGH76076.1.4	SPRING RETAINER	1
GN5250-G-05	BGH76076.1.5	STARTER RATCHET	2
GN5250-G-06	BGH76076.1.6	RETURN SPRING	2
GN5250-G-07	BGH76076.1.7	RECOIL STARTER ROPE	1
GN5250-G-08	BGH76076.1.8	REC OIL STARTER SPRING	1
GN5250-G-09	BGH76076.1.9	PRESSURE PLATE	1
GN5250-G-10	BGH76076.1.10	STOP ROP PLATE	1
GN5250-G-11	BGH76076.1.11	PROTECTIVE CAP	1
GN5250-G-12	BGH76076.1.12	RECOIL STARTER CASE COMP	1
GN5250-G-13	BGH46076.1.14	RECOIL ROPE	1
GN5250-G-14	BGH46076.1.15	STARTER KNOB	1



## Fan cover system

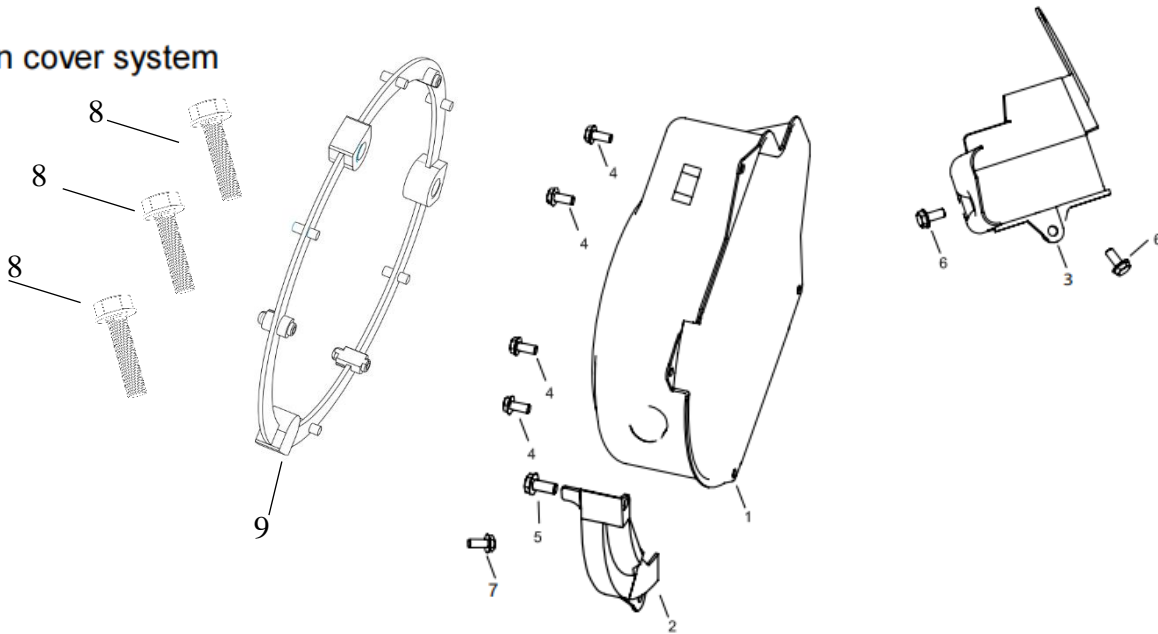

## H

GPA Parts No.	Parts No.	Description	Qty
GPG4000-H-01	BGH76120	FAN COVER COMP.	1
GPG4000-H-02	PGH46163	FLYWHEEL SIDE PLATE	1
GPG4000-H-03	PGH46186	SHROUD	1
GPG4000-H-04	PGS40003	FLANGE BOLT (M6 X 12)	4
GPG4000-H-05	PGS40007	FLANGE BOLT (M6 X 20)	1
GPG4000-H-06	PGS40000	FLANGE BOLT (M6 X 10)	2
GPG4000-H-07	PGS40019	FLANGE BOLT (M6 X 8 )	1
GPG4000-H-08	PGS40062	BOLT (M6 X 20 )	3
GPG4000-H-09	PGS46750	PLASTIC ISOLATOR RECOIL	1

# 5250W Dual Fuel Generator

Carburetor system assy.

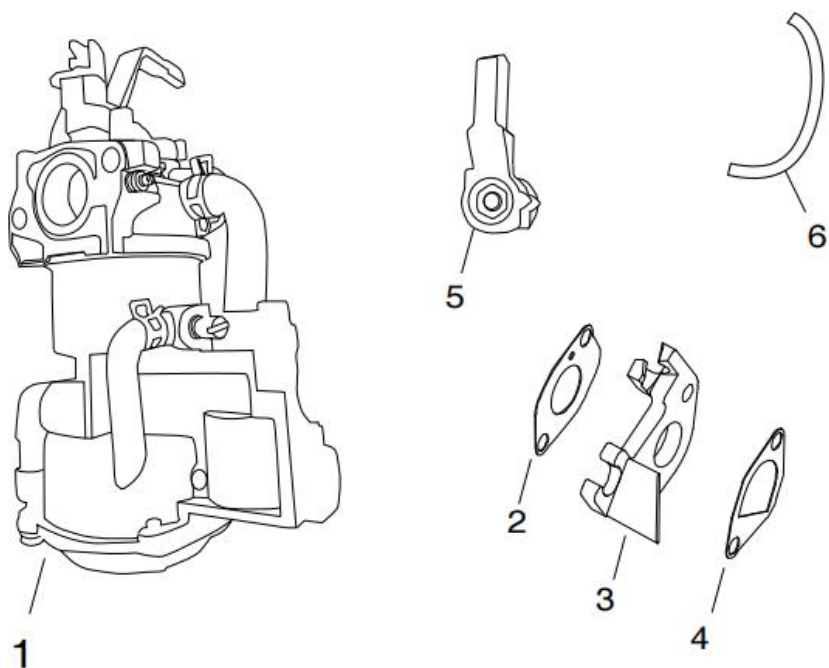

GPA Parts No.	Parts No.	Description	Qty
GN5250-I-01	PGH48503.1	CARBURETOR ASSY .	1
GPG4000-I-02	PGH44128	CARBURETOR PAPER GASKET	1
GPG4000-I-03	PGH44150	CARBURETOR INSULATING PLATE	1
GPG4000-I-04	PGH44203	INTAKE PIPE GASKET	1
GN5250-I-05	PGH48503.2	FUEL SELECTOR SWITCH	1
GN5250-I-06	PGH48503.3	FUEL HOSE	1

## Flywheel system assy.

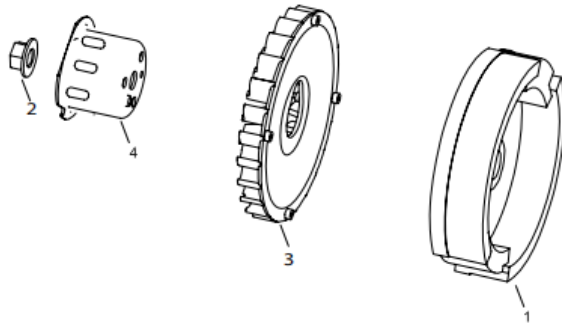

## J

GPA Parts No.	Parts No.	Description	Qty
GPG4000-J-01	PGH42461	FLYWHEEL	1
GPG4000-J-02	PGH42475	FLYWHEEL NUT (M14X1.5 )	1
GPG4000-J-03	PGH42500	COOLING FAN	1
GPG4000-J-04	PGH76129	STARTER PULLEY	1

# 5250W Dual Fuel Generator

## Ignition System Assy.

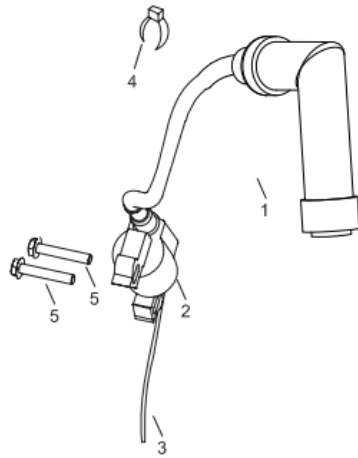

**K**

GPA Parts No.	Parts No.	Description	Qty
GPG4000-K-01	PGH44675.2-1	NOISE SUPPRESSOR CAP ASSY	1
GPG4000-K-02	PGH44675.2-2	IGNITION COIL ASSY	1
GPG4000-K-03	PGH44675.2-3	STOP SWITCH CORD	1
GPG4000-K-04	PGH44675-3	STOP SWITCH CORD HOLDER	1
GPG4000-K-05	BGS40009	FLANGE BOLT (M6 X 25)	1

## Control system assy.

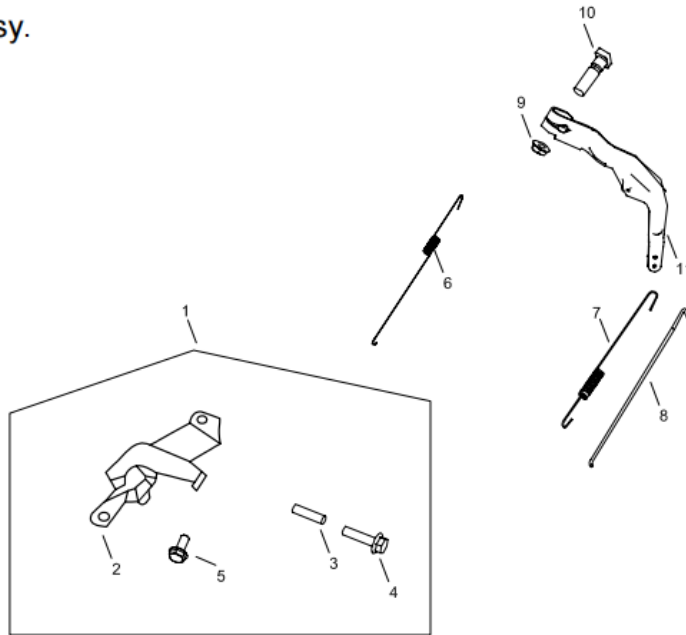

**L**

GPA Parts No.	Parts No.	Description	Qty
GPG4000-L-01	PGH45092	CONTROL UNIT ASSY.	1
GPG4000-L-02	PGH45078-2	CONTROL BASE COMP.	1
GPG4000-L-03	PGH45078-3	CONTROL AJUSTING SPRING	1
GPG4000-L-04	PGH45078-7	PAN SCREW (M5 X 25)	1
GPG4000-L-05	PGS40003	FLANGE BOLT (M6 X 12)	2
GPD5000-L-06	PGH45503	THROTTLE RETURN SPRING	1
GPG4000-L-07	PGH45525	GOVERNOR SPRING	1
GPD5000-L-08	PGH48600	GOVERNOR ROD	1
GPG4000-L-09	PGS20000	FLANGE NUT (M6)	1
GPG4000-L-10	PGS45415	GOVERNOR ARM BOLT (M6)	1
GPG4000-L-11	PGH45575	GOVERNOR ARM	1

# 5250W Dual Fuel Generator

## Air cleaner

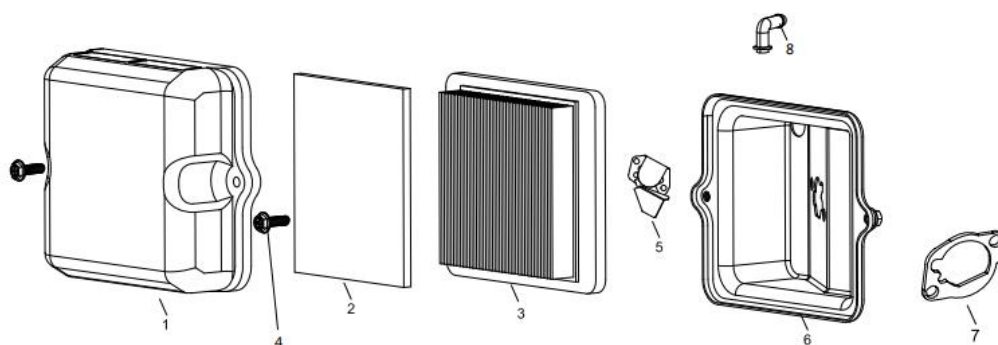

**M**

GPA Parts No.	Parts No.	Description	Qty
GN5250-M-01	PGH32652	AIR CLEANER COVER COMP	1
GN5250-M-02	PGH32726	FILTER ELEMENT PANEL PAPER	1
GN5250-M-03	PGH32725	ELEMENT FILTER	1
GN5250-M-04	PGS70001	HEX HEAD BOLT M6X22	2
GN5250-M-05	PGH32675	INTAKE BACKFIRE PLATE	1
GN5250-M-06	PGH32700	AIR CLEANER CASE COMP	1
GN5250-M-07	PGH44107	GASKET	1
GN5250-M-08	PGH62825	TUBE	1

## Muffler System Assy.

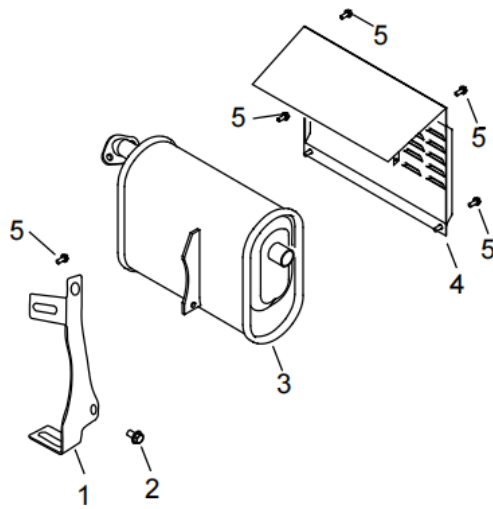

**N**

GPA Parts No.	Parts No.	Description	Qty
GPD4000-N-01	PGH32605	AIR CLEANER COVER COMP	1
GPD4000-N-02	PGH32605	FILTER ELEMENT PANEL PAPER	1
GPD4000-N-03	PGH32605	ELEMENT FILTER	4
GN5250-N-01	PGH32605	HEX HEAD BOLT M6X22	1
GN5250-N-01	PGH32605	INTAKE BACKFIRE PLATE	1
GN5250-N-01	PGH32605	AIR CLEANER CASE COMP	1
GN5250-N-01	PGH32605	GASKET	1
GN5250-N-01	PGH32605	TUBE	2

# 5250W Dual Fuel Generator

Fuel tank system assy.

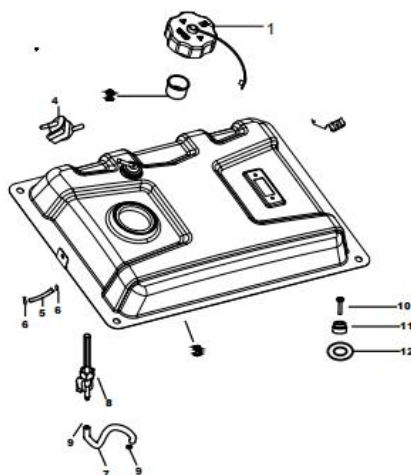

**O**

GPA Parts No.	Parts No.	Description	Qty
GN5250-O-01	BGG21006.1	FUEL FILLER CAP COMP	1
GPG4000-O-02	BGG21006.2	FUEL FILTER	1
GN5250-O-03	BGG20558.1	FUEL TANK COMP.	1
GPG4000-O-04	BGG64228	OVERFLOW VALVE	1
GPG4000-O-05	BGH63687	FUEL TUBE A	1
GPG4000-O-06	BGH43582	TUBE CLIP A	2
GPG4000-O-07	BGH43602	FUEL TUBE D	1
GPG4000-O-08	BGH43625	FUEL VALVE	1
GPG4000-O-09	BGH63575	TUBE CLIP C	2
GPG4000-O-10	BGS40009	FLANGE BOLT (M6x25)	4
GN5250-O-11	BGH20558.2	RUBBER	4
GPG4000-O-12	BGG20503	WASHER	4



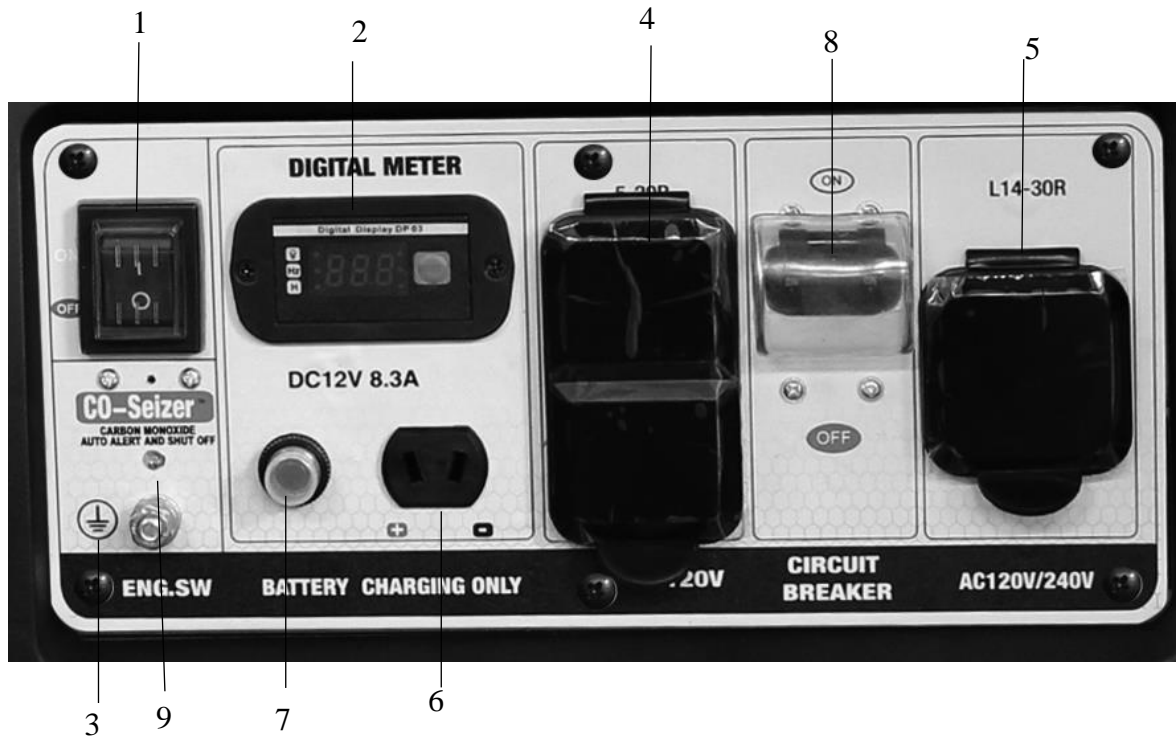

## P

GPA Parts No.	Parts No.	Description	Qty
GPG4000-P-01	BGG50200	ENGINE SWITCH ASSY	1
GPG4000-P-02	BGG52950	DIGITAL METER	1
GPG4000-P-03	BGG50705	EARTH TERMINAL	1
GPG4000-P-04	BGG53350	120V 20A NEMA 5-20 RECEPTACLE	1
GPG4000-P-05	BGG53400	120V/240V 30A NEMA L14-30 RECEPTACLE	1
GPG4000-P-06	BGG53650	DC SOCKET	1
GPG4000-P-07	BGG52100	DC CIRCUIT PROTECTOR	1
GPG4000-P-08	BGG52155	CIRCUIT BREAKER	1
GPG4000-P-09	BGG55052	CO SEIZER ALARM	1

---

# 5250W Dual Fuel Generator

---

Frame Comp ASSY.

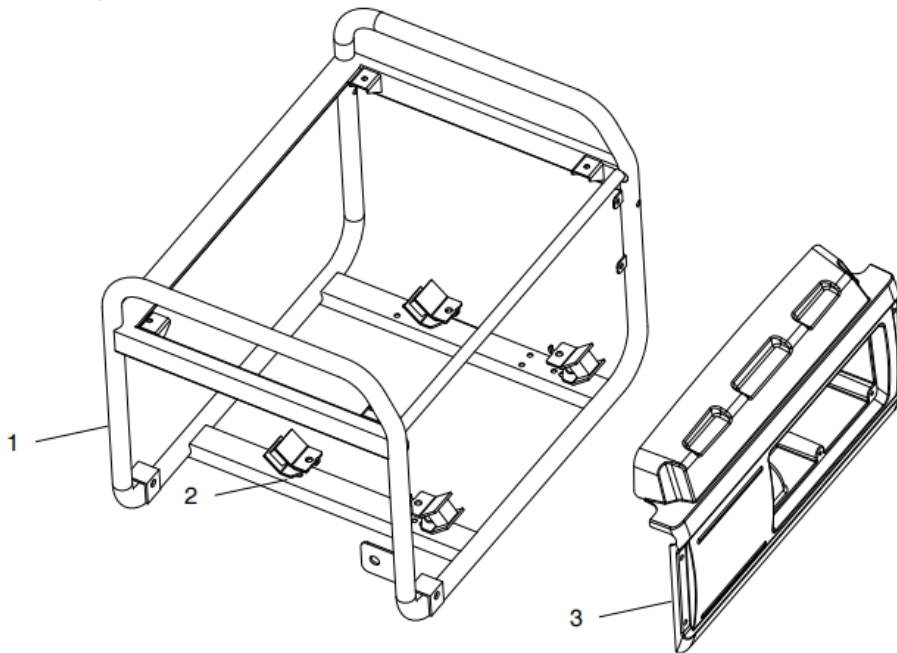

**Q**

GPA Parts No.	Parts No.	Description	Qty
GN5250-Q-01	BGG40342	GENERATOR FRAME	1
GPG4000-Q-02	BGG61006	BOTTON RUBBER A	4
GPG5000-Q-02	BGG50068.2	CONTROL PANEL CASE	1

## Generator.

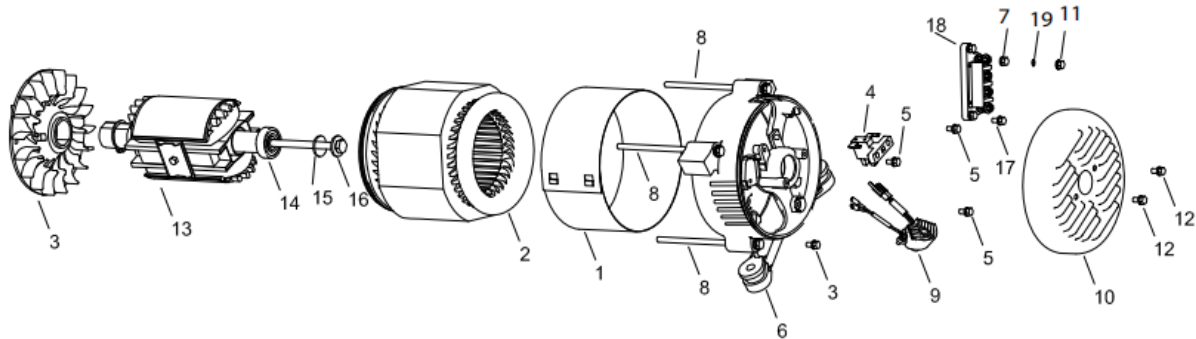

# R

GPA Parts No.	Parts No.	Description	Qty
GPD5000-R-01	BGG11903.1.2	STATOR COVER	1
GPD5000-R-02	BGG11903.1.3	STATOR ASSY.	1
GPD5000-R-03	BGG11903.1.4	COOLING FAN	1
GPG4000-R-04	BGG13100	BRUSH ASSY.	1
GPG4000-R-05	BGS14022	TAPPING SCREW	6
GPG4000-R-06	BGG13300	GENERATOR STAY	1
GPG4000-R-07	BGS10001	NUT (5mm)	4
GPD5000-R-08	BGG14052	FLANGE BOLT (M6X170)	4
GPG4000-R-09	BGG12508	AUTO VOLTAGE REG. ASSY.	1
GPG4000-R-10	BGG13004	REAR COVER	1
GPG4000-R-11	BGS10001	NUT	4
GPG4000-R-12	BGS40078	FLANGE BOLT	2
GPD5000-R-13	BGG11903.1.5	ROTOR COMP.	1
GPD5000-R-14	BGG11903.1.6	BEARING ASSY.	1
GPG4000-R-15	BGS60004	PLAIN WASHER	1
GPD5000-R-16	BGG14012	FLANGE BOLT (M8X227)	1
GPG4000-R-17	BGS30039	HEX. BOLT (M5 X 20)	2
GPG4000-R-18	BGG13200	VOLT CHANGE TERMINAL BR-AC-W	1
GPG4000-R-19	BGS60001	PLAIN WASHER (5mm)	4

# 5250W Dual Fuel Generator

Wheel & Hand Assy.

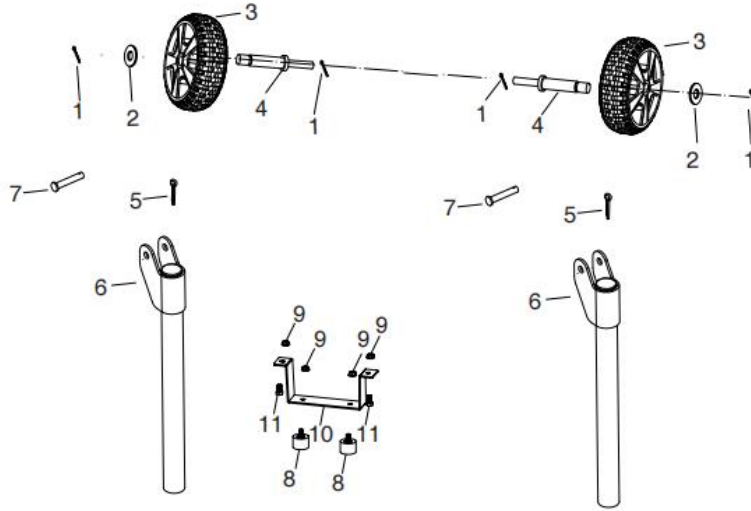

**S**

GPA Parts No.	Parts No.	Description	Qty
GPG5250-S-01	BGS61001	SPLIT PIN	4
GPG6500-S-02	BGS20006.1.2	WASHER PLAIN	2
GPD5000-S-03	BGG60649	WHEEL	2
GPD5000-S-04	BGS42004	SHAFT	2
GN5250-S-05	BGS61001	SPLIT PIN	2
GN5250-S-06	BGG42113	HANDLE	2
GN5250-S-07	BGS30019	BOLT(M8*40)	2
GPG6500-S-08	BGS61005	RUBBER	2
GPG6500-S-09	BGS20002	FLANGE NUT(M8)	2
GPD5000-S-10	BGG42051	STANDER	1
GPG6500-S-11	BGS30009	FLANGE BOLT(M8*25)	1

Distributed by:

Green-Power America, LLC

[www. Green-PowerAmerica.com](http://www.Green-PowerAmerica.com)

All copyright c is reserved by Green-Power America, LLC

GPA reserves the right of any amendment on the manual without notice