

TOMAHAWK

TG5500i
INVERTER GENERATOR

Operations Manual

FIND THE HOW TO GUIDE ON

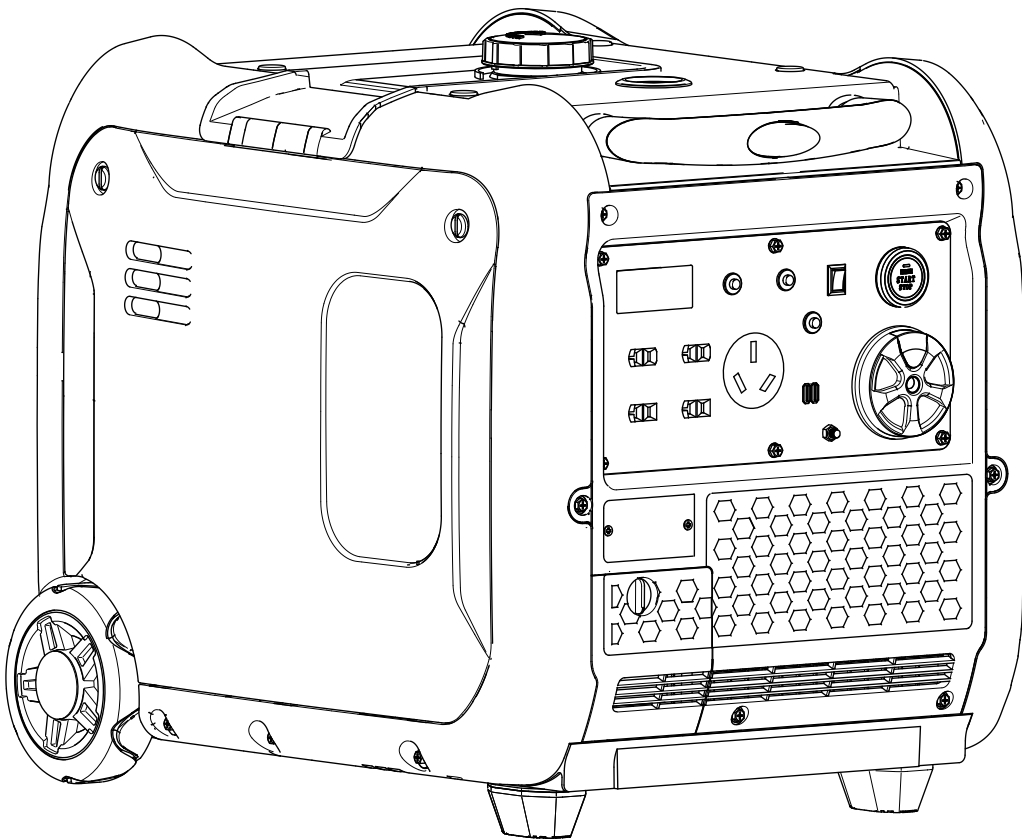

Thank you for choosing a Tomahawk Generator!

Please read this manual carefully before operating. Safely and correctly operating your generator will ensure you get the best results.

All information in this publication is based on the latest product information available at the time of printing. The contents in this manual may be different from the actual parts due to revision and other changes.

Tomahawk Power, LLC reserves the right to make changes at any time without notice and without incurring any obligation. No part of this publication may be reproduced without written permission from Tomahawk Power, LLC.

This manual should be considered a permanent part of the generator and should remain with the generator if it is resold.

SAFETY

Your safety and the safety of others are very important. We have provided important safety information in this manual and on the generator. Please read these messages carefully.

A safety message alerts you to potential hazards that could hurt you or others. Each safety message is preceded by a safety alert symbol and one of three words: DANGER, WARNING, or CAUTION:

DANGER

You **WILL** be **KILLED** or **SERIOUSLY HURT** if you do not follow instructions.

WARNING

You **CAN** be **KILLED** or **SERIOUSLY HURT** if you do not follow instructions.

CAUTION

You **CAN** be **SERIOUSLY HURT** if you do not follow instructions.

NOTICE

Your generator or other property could be **DAMAGED** if you do not follow instructions.





CONTENTS

GENERATOR.....	1
SAFETY MESSAGES	3
1. SAFETY NOTICE.....	5
1. Safety Standard	5
2. Special Requirements	6
2.COMPONENT IDENTIFICATION.....	7
1. Component Identification	7
2. Engine Type & Serial Number.....	8
3. CONTROLFUNCTION	9
1. Oil warning light (red).....	9
2. Overload indicator light (Red)	9
4. PREPARATION.....	11
1. Fuel.....	11
2 Engine oil	11
3. Recoil Starter	12
4. Fuel Valve	12
5. AC Circuit Breaker/Over current Protector	12
6. Ground Terminal	13
5. GENERATOR OPERATION	14
1. Connection to the Household Power Supply.....	14
2.GeneratorGrounding	15
3.ACCurrent	15
4. DC Current.....	16
5. High Altitude Operation.....	16
6. STARTING THE ENGINE	17
1. Recoil Starter	17
2. Electric starting	18
7. STOPPING THE ENGINE	18
8. MAINTENANCE	19
1. Engine Oil Change.....	20
2. Air Cleaner Service	21
3. Fuel Sediment Cup Cleaning	22
4. Spark Plug Service	23
9. STORAGE.....	23
10. TROUBLESHOOTING	25
11. WIRING DIAGRAM	26
12. SPECIFICATIONS	27

1. SAFETY NOTICE

1. Safety Standard

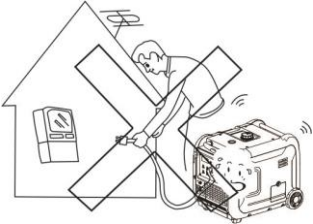
Read and understand this owner's manual before operating your generator. You can help prevent accidents by being familiar with your generator's controls, and by observing safe operating procedures.

	
<p>DO NOT operate indoors</p>	<p>DO NOT operate in the wet conditions</p>
	
<p>DO NOT directly connect to a household power supply</p>	<p>DO NOT smoke when refueling</p>



DO NOT overflow the fuel when refueling

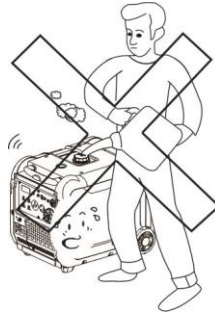

Stop the engine before refueling

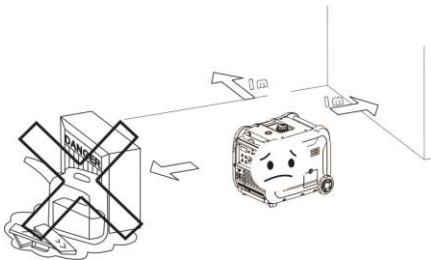

Keep the generator at least 10 feet far away from any flammable materials

2. Special Requirements

Electrical equipment including lines and plug connections should not be damaged in any way or have exposed wires.

The circuit breakers that have been installed match with the provided generator.

If the circuit breakers require replacement, the replacement must be a circuit breaker with identical ratings and performance characteristics.

DO NOT operate the generator before grounding.

If using extension cords, be sure to check the electrical needs of your appliance, as electrical power is lost over distance. Use this rule: if your extension cord is #16 gauge wire, you can have a cord up to 50 feet. For the same appliance, if your cord is #10 gauge, your maximum length is 250 feet.

2.COMPONENT IDENTIFICATION

1. Component Identification

TG5500i

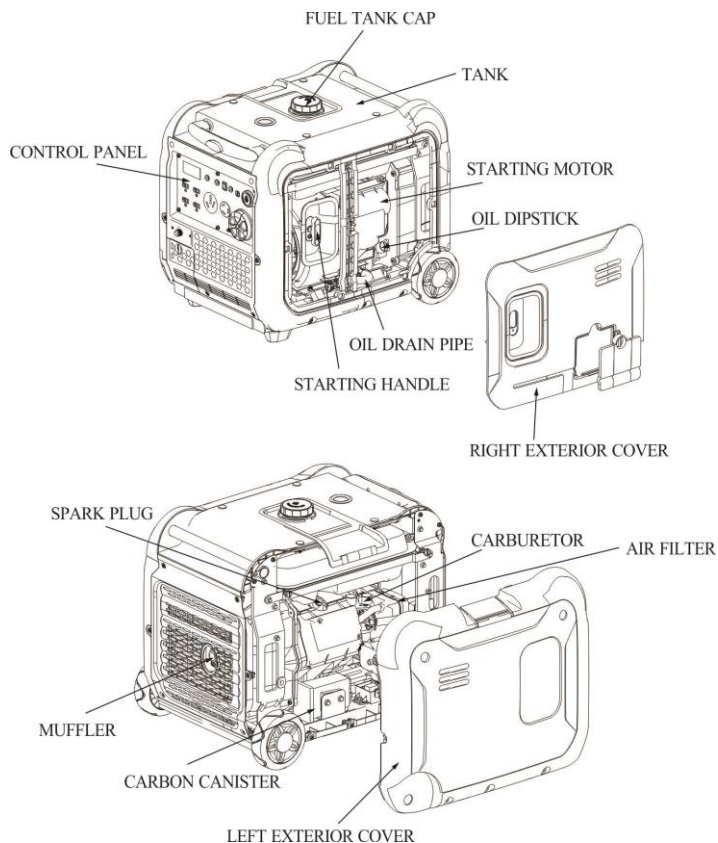

2. Engine Type & Serial Number

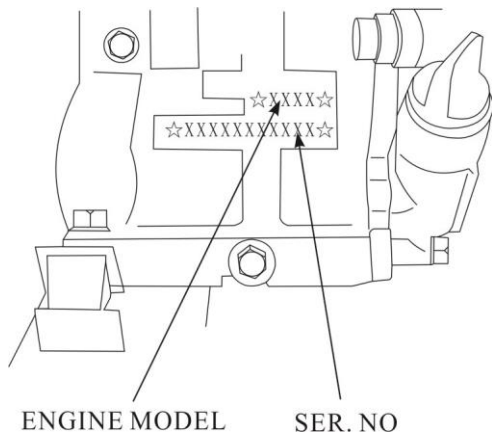

3. CONTROL FUNCTION

1. Oil warning light (red)

When the oil level falls below the required level, the oil warning light will turn on and the engine will stop automatically. Unless you refill with oil, the engine will not start again.

Tip: If the engine stalls or does not start, turn the engine switch to “ON” and then pull the recoil starter.

If the oil warning light flickers for a few seconds, the engine oil is insufficient. Add oil and restart.

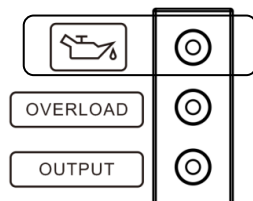

2. Overload indicator light (Red)

The overload indicator light comes on when an overload of a connected electrical device is detected, the inverter control unit overheats, or the AC output voltage rises. Then, the AC protector will trip, stopping power generation to protect the generator and any connected electrical devices. The AC pilot light (Green) will go off and the overload indicator light (Red) will stay on, but the engine will not stop running.

When the overload indicator light comes on and power generation stops, proceed as follows:

- 1) Turn off any connected electrical devices and stop the engine.
- 2) Reduce the total wattage of connected electrical devices within the rated output.
- 3) Check for blockages in the cooling air inlet and around

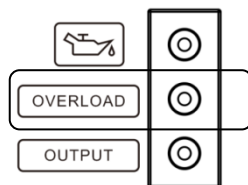

the control unit.

If any blockages are found, remove.

4) After checking, restart the engine.

Tip: The overload indicator light may come on for a few seconds at first when using electrical devices that require a large starting current, such as a compressor or a submersible pump.

However, this is not a malfunction.

3. AC pilot light (Green)

The AC pilot light comes on when the engine starts and produces power.

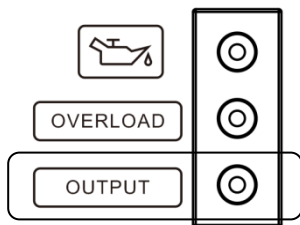

4. Engine smart control (ECO)

① "ON"

When the ECO switch is turned to "ON", the economy control unit controls the engine speed according to the connected load. The results are better fuel consumption and less noise.

② "OFF"

When the ECO switch is turned to "OFF", the engine runs at the rated/min (3600r/min) regardless of whether it is connected to a load.

Tip: The ECO switch must be turned to "OFF" when using electrical devices that require a large starting current, such as a compressor or a submersible pump.



5. Ground (Earth) Terminal

The Ground (Earth) terminal connects the ground line for prevention of electric shock. When the electric devices are grounded, always ground the generator.

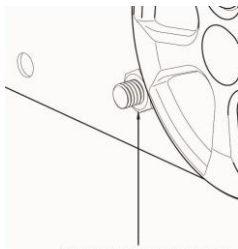

4. PREPARATION

1. Fuel

DANGER!

Fuel is highly flammable and dangerous. Check “SAFETY INFORMATION” carefully before filling.

Do not overfill the fuel tank, or it may overflow when the fuel warms up and expands.

After filling the fuel tank, make sure the fuel tank cap is tightened securely.

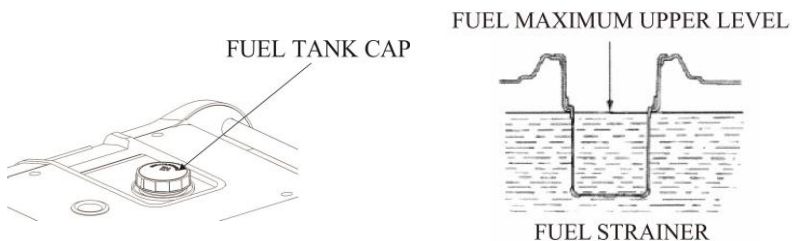

NOTICE

Immediately wipe off spilled fuel with a clean, dry, soft cloth. Fuel may deteriorate painted surfaces or plastic parts.

Use unleaded gasoline only, as leaded gasoline can severely damage internal parts of the generator.

Remove the fuel tank cap and fill the tank to the red level.

Recommended fuel: Unleaded gasoline

Fuel tank capacity: 4.5 gallons

2. Engine Oil

The generator has been shipped without engine oil. **DO NOT** start the engine until it is filled with sufficient engine oil.

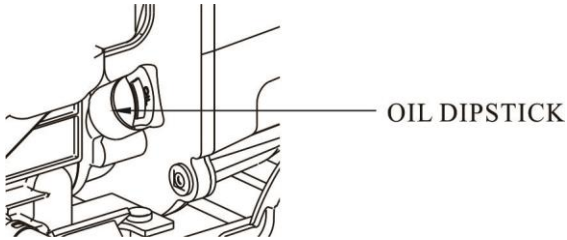

3. Recoil Starter

To start the engine, pull the starter grip lightly until resistance is felt, then pull quickly.

Do not allow the starter to snap back against the engine. Return it gently to prevent damage to the starter.

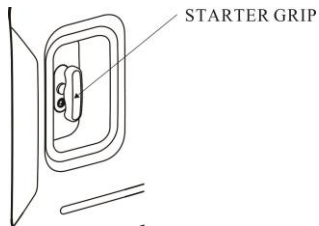

4. Fuel Valve

The fuel valve controls fuel flowing from the fuel tank to the carburetor. Be sure to return the lever to “OFF” after stopping the engine.

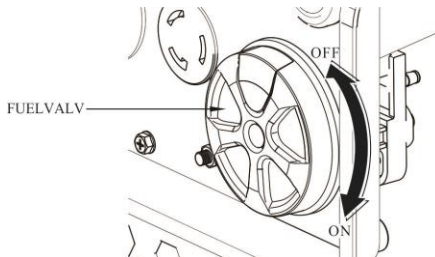

5. AC Circuit Breaker/Over Current Protector

The overload current will automatically switch off the circuit

breaker to avoid a short circuit of the load or overload. If the indicator of the AC Over current Protector is raised, the Over current Protector is now in the “OFF” position. Press the button of the AC Over current Protector to the “ON” position again 1 min later. If the circuit breaker is switched OFF automatically, switch the circuit breaker ON again.



6. Ground Terminal

This ground terminal is used to connect the generator.

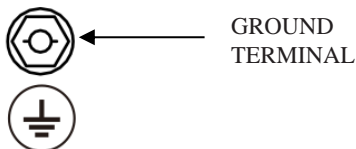

5. GENERATOR OPERATION

Generator operation environment:

- Temperature: 23°F ~ 100°F (-5°C ~ 40°C)
- Humidity: Below 95%
- Height above sea level:

Power output can be expected to decrease by an average of 3.5% per 1000ft above sea level. When operating at extreme altitudes, carburetor adjustments are recommended to maintain proper output.

1. Connection to the Household Power Supply

NOTICE

When connecting the generator to the household power supply, connection must be made by a qualified electrician. After connecting, carefully check the electric connection for safety and reliability. Incorrect electrical connections may cause generator damage and/or a fire hazard.

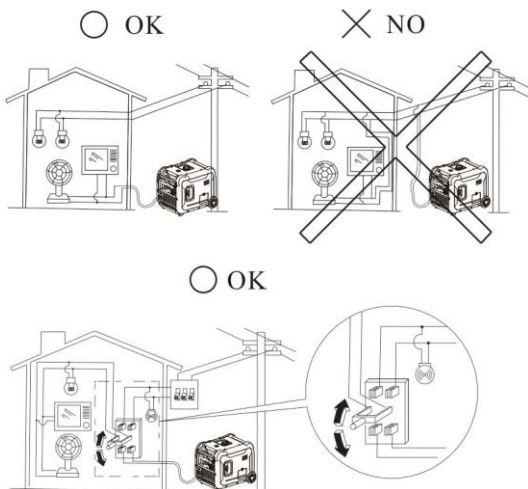

2. Generator Grounding

To prevent electrical shock or misuse from faulty appliances, the generator should be grounded with an insulated lead.

3. AC Current

Before starting the generator, make sure that the total load (Total resistance, capacitive and inductive) does not exceed the rated power of the generator.

NOTICE





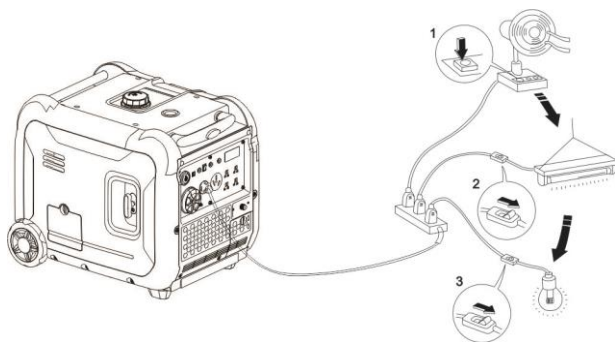



Overload operation will shorten generator life.

If the generator set is connected to multiple loads or electric appliances, connect each appliance 1 at a time, starting with the highest load appliance first. Allow the generator to adjust to each load before adding more.



The following table is a reference for when connecting to

the electric appliances.

Type	Wattage		Typical Device	Examples		
	Start	Rated		Device	Starting	Rated
Incandescent Lamp Heating Device	×1	×1	 Incandescent Lamp  Tv Set	 Incandescent Lamp 100W	100VA (W)	100VA (W)
Fluorescent Lamp	×2	×1.5	 Fluorescent Lamp	 Fluorescent Lamp 40W	80VA (W)	60VA (W)
Motor Drive Device	×3-5	×2	 Refrigerator  Electric Fan	 Refrigerator 150W	450-750VA (W)	300VA (W)

4. DC Current

DC Terminals

The DC terminals are used to provide a DC power supply for lower power loads such as charging a battery.

The terminals are colored red to identify the positive (+) terminal and black to identify the negative (-) terminal. Load connection method: The load must be connected to DC terminals with the proper polarity (load positive to positive of DC terminal and load negative to negative of DC terminal).

5. High Altitude Operation

At high altitude, the standard carburetor air-fuel mixture will be excessively rich. Output power will decrease, and fuel consumption will increase.

Engine performance can be improved by installing a smaller diameter main fuel jet in the carburetor and readjusting the

pilot screw. If you always operate the engine at altitudes 3500 feet above sea level, you should have a Tomahawk Power authorized dealer perform this carburetor modification. If not, you should lower the load in the operating generator.

Even with the right carburetor, engine horsepower will decrease approximately 3.5% for every 1000-foot increase in altitude. If no carburetor adjustments are made for high altitude operation, this will have a major negative effect on horsepower output.

NOTICE

If a carburetor for high altitude is equipped with an engine and operated at a lower altitude, the lean air fuel mixture will cause the engine output power to lower, over-heat and seriously damage the unit.

6. STARTING THE ENGINE

1. Recoil Starter

- (1) Remove all the loads out of the output.
- (2) Turn the fuel valve to the “ON” position.
- (3) Turn the AC circuit breaker to the “OFF” position.
- (4) Turn the choke lever to the “CLOSE” position.

NOTICE

Don't close the choke when starting a warm engine

- (5) Turn the generator switch to the “ON” position.
- (6) Pull the starter grip until compression is felt, then pull briskly.
- (7) Turn the choke lever to the “OPEN” position after the engine is warm.

(8) Don't use any electric apparatus before setting the circuit breaker to the "ON" position.

2. Electric starting

- (1) Remove all the loads out of the output.
- (2) Turn the fuel valve to the "ON" position.
- (3) Turn the choke lever to the "CLOSE" position.

⚠ WARNING

Don't close the choke when starting a warm engine

- (4) Turn the generator switch to electric starting position.
- (5) After starting engine, immediately release generator switch and generator switch can automatically return to open position.
- (6) Turn the choke lever to "OPEN" position after the engine is warm.

NOTICE

Turning the gasoline switch to the electric starting position for more than 5 seconds can damage the starting motor. If failing to start, release the switch and wait 10 seconds before operating it again.

If the speed of the starting motor drops fast after a period of time, it means that the battery should be recharged.

7. STOPPING THE ENGINE

- (1) Turn the AC circuit breaker to the "OFF" position.
- (2) Turn the generator switch to the "OFF" position.
- (3) Turn the fuel valve to the "OFF" position.

NOTICE

To stop the engine in an emergency, turn the generator switch to the “OFF” position.

8. MAINTENANCE

The engine must be properly maintained to ensure its operation is safe, trouble-free, as well as eco-friendly.

In order to keep your gasoline engine in good working condition, it must be periodically serviced. The following maintenance schedule and routine inspection procedures must be carefully followed:

Items	Frequency		Each time	First 1 month or first 20hrs of operation	Thereafter, every 3 months or every 50hrs of operation	Every year or every 100 hrs of operation
Engine oil	Check- Refill		√			
	Replace			√	√	
Air filter element	Check		√			
	Clean			√		
	Replace				√	
Deposit Cup(if equipped)	Clean					√
Spark Plug	Check - adjust					√*
Spark arrester	Clean				√	
Idling (if equipped) **	Check - adjust					√
Valve clearance **	Check-adjust					√
Fuel tank & fuel filter **	Clean					√
Fuel line	Check	Every 2 years(change if necessary)				
Cylinder head, piston	Clean up carbon **	$<225\text{cc}$, Every 125hrs $\geq 225\text{cc}$, Every 250hrs				
* These items should be replaced if replacement needed.						
** These items should be maintained and repaired by our authorized dealer, unless the owner has appropriate tools and is proficient with mechanical maintenance.						

NOTICE

- If the gasoline engine is frequently worked under high temperature or at a high load, change the oil every 25 hours.
- If the engine is frequently worked under dusty or other

severe circumstances, clean the air filter element every 10 hours; If necessary, change the air filter element every 25 hours.

- Maintain the generator based on whatever number comes first: the hours of operation, or the timeframe (ex: oil change every 3 months)
- If you have missed the scheduled time to maintain your engine, do it as soon as possible.

⚠ WARNING

Stop the engine before servicing. Put the engine on a level surface and remove the spark plug cap to prevent the engine from starting.

Never run your engine in a poorly ventilated room or other enclosed area, be sure to keep good ventilation in the working area. The exhaust from the engine may contain poisonous CO, and inhalation can cause shock, unconsciousness and even death.

1. Engine Oil Change

Drain the oil while the engine is warm to assure complete and rapid draining.

1. Remove the oil dipstick and drain plug to drain the oil.
2. Reinstall the drain plug, then tighten the plug securely.
3. Refill oil and check the oil level.

Oil capacity: 28.7 fl oz

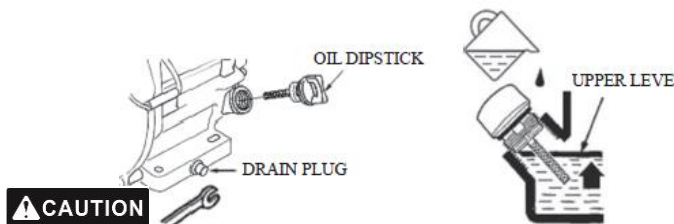

Used engine oil may cause skin cancer if repeatedly left in contact with the skin for prolonged periods. Although this is unlikely unless you handle used oil on a daily basis, it is still advisable to thoroughly wash your hands with soap and water as soon as possible after handling used oil.

Please dispose of used engine oil in a manner that is compatible with the environment. We suggest you take it in a sealed container to your local service station or recycling center for reclamation. Do not throw it in the trash or pour it on the ground.

2. Air Filter Service

A dirty air cleaner will prevent air from flowing into the carburetor. To prevent carburetor malfunction, maintain the air Filter regularly. Maintain more frequently when operating the generator in extremely dusty areas.

⚠ CAUTION

Using gasoline or flammable solvent to clean the filter element can cause a fire or explosion. Use only soapy water or nonflammable solvent.

NOTICE

Never run the generator without the air filter. If not, rapid engine wear will result.

(1) Open the air filter clip and open the air cover. Check the air filter element for complete and clean.

(2) If the air filter element is dirty, please clean the air filter element:

Wash the air filter element in a solution of household detergent and warm water, then rinse thoroughly or wash in nonflammable or high flash point solvent: Drop a few points engine oil in, then, squeeze out.

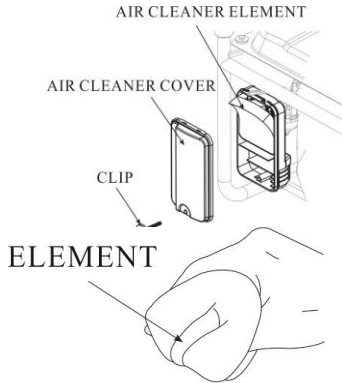

(3) Reinstall the air filter element and the cover.

3. Fuel Sediment Float Bowl Cleaning

(1) Turn the fuel valve to the OFF position. Remove the float bowl cup, O-ring and strainer according to the arrow direction.

(2) Clean the sediment cup, and O-ring, and strainer in a nonflammable or high flash point solvent.

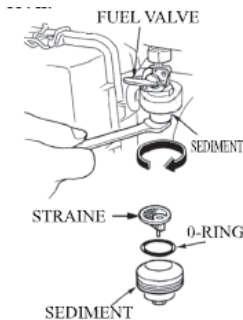

(3) Reinstall O-ring, and strainer and screw down the sediment cup.

(4) Turn the fuel valve ON and check for leaks.

4. Spark Plug Service

Recommended spark plugs: F7RTC or other equivalents

- (1) Remove the spark plug cap.
- (2) Use the plug wrench to remove the spark plug.
- (3) Visually inspect the spark plug if the insulator is cracked, if cracked, replace with new the spark plug.
- (4) Measure the plug gap with a feeler gauge. Correct as necessary by carefully bending the side electrode. The gap should be: 0.70-0.80 mm.
- (5) Check the spark plug washer.
- (6) Reinstall the spark plug, tighten it with a plug wrench and impact the washer. Reinstall the spark plug.

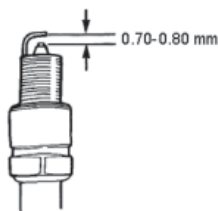

9. STORAGE

⚠ WARNING

In order to prevent a hot engine or exhaust system causing burns or fires, let the engine cool before storing the generator. If storing the unit for an extended period of time, be sure the storage area is free of excessive humidity and dust.

- (1) Drain the fuel in the fuel tank out, clean strainer, O-ring and sediment, and replace. Drain the fuel out of the carburetor by loosening the drain bolt, then refitting it and screwing down

the carburetor bolt.

 **WARNING**

Gasoline is extremely flammable and is explosive under certain conditions. Drain fuel in a well-ventilated area with the engine stopped. Do not smoke or allow flames or sparks in the area during this procedure.

(2) Screw the oil dipstick off and screw the drain bolt off the crankcase to completely drain the oil out. Then screw down the drain bolt and fill fresh oil to the upper mark, finally replace the oil dipstick.

(3) Remove the spark plug and pour about a tablespoon of clean engine oil into the cylinder. Crank the engine several revolutions to distribute the oil, then reinstall the spark plug.

(4) Slowly pull the starter grip until resistance is felt. Let the intake and exhaust valves in closing position.

(5) Place the generator in the clean area.

10. TROUBLESHOOTING

Engine will not start:

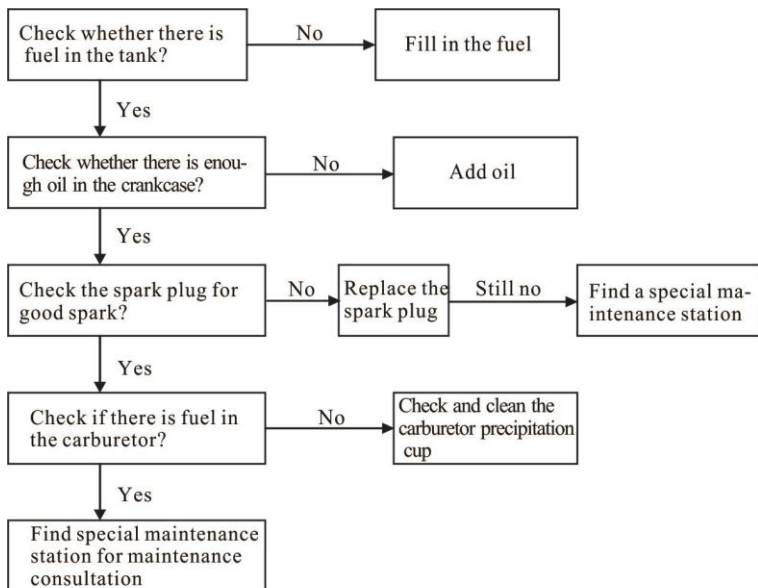

There is no voltage :

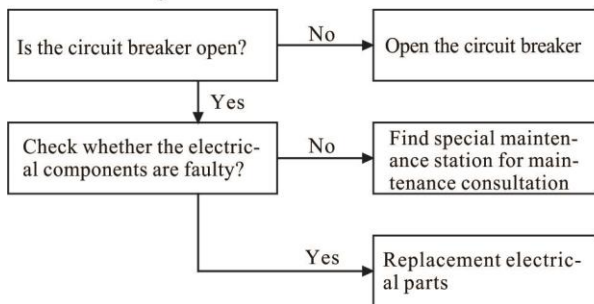

11. WIRING DIAGRAM

TG5500i Electrical schematic diagram

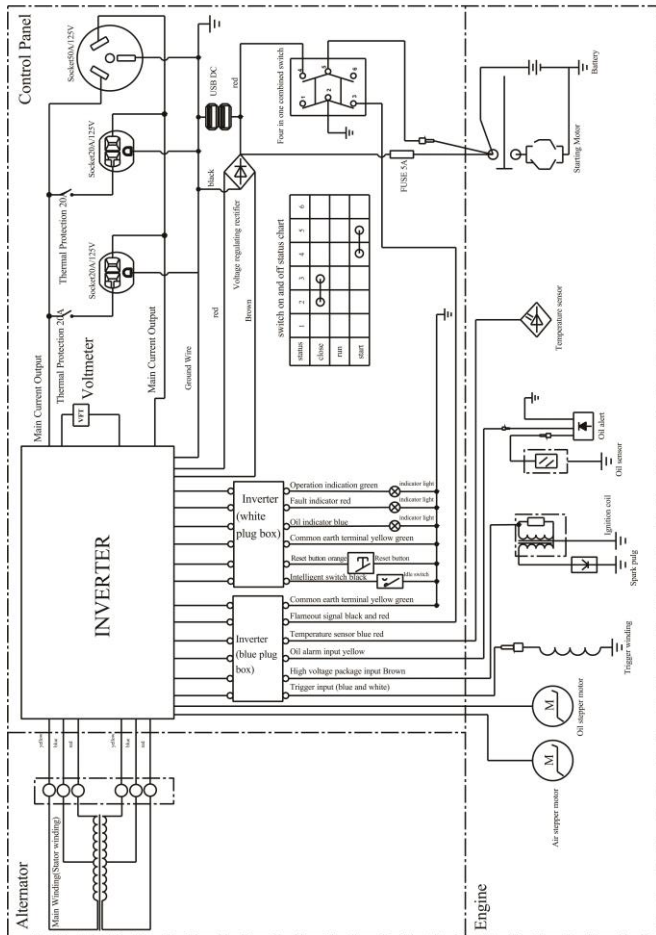

12. SPECIFICATIONS

	Item	TG5500i
Gasoline Engine	Gasoline Engine	Single Cylinder, 4-Stroke, Forced Air Cooling,
	Displacement (cc)	312
	Igniting System	CDI
	Oil Capacity (L)	0.85
Generator	Fuel Volume (L)	17
	Rated Frequency	50/60
	Rated Voltage (V)	230/120/240
	Rated Output	5
	Maximum Output Power (kW)	5.5
	DC(V/A)	12/8.3
Generator Set	Length (mm)	565
	Width (mm)	460
	Height (mm)	450
General-Purpose Accessory	Large Air Cleaner	•
	Large Muffler	•
	Large Fuel Tank	•
	Fuel Gauge	•
	Voltmeter	•
	Automatic Voltage Regulator(AVR)	•
	Oil Alert System	•
	Non-fuse Breaker	•
Electric Starting Accessory	•	

Notes: • means available, - means unavailable

TOMAHAWK

COMPACTION



3,550 lbs/ft Vibratory Rammer
Part#: TR68H

3.6 HP Honda GXR120 Engine
Easily achieve a 100% compaction rating
3-in-One Fuel System with carburetor protection
13" x 11" plate for narrow trenches and corners
3 Year Engine Warranty & 1 Year Product Warranty



3,400 lbs/ft Plate Compactor
Part#: TPC90H

5.5 HP Honda GX160 Engine
Easily achieve a 100% compaction rating
22" x 20" cold, rolled steel beveled base plate
Includes 3.5 gallon water tank for asphalt compaction
3 Year Engine Warranty & 1 Year Product Warranty



3,000 lbs/ft Plate Compactor
Part#: TPC80 & TPC80H

6 HP Kohler CH260 & 5.5 HP Honda GX160 Engines
Easily achieve a 100% compaction rating
16.5" x 21.5" plate for narrow trenches and corners
Optional Honda Engine model: TPC80H
3 Year Engine Warranty & 1 Year Product Warranty

FINISHING



6.5 Gal Backpack Concrete Sprayer
Part#: TCS6.5

Maintain constant, adjustable pressure up to 450 PSI
Achieve superior concrete finishes with even spraying
Spray 15,000 sq ft in less than 10 minutes
Compatible with major manufacturer wands
1 Year Product Warranty



1.6 HP Vibratory Concrete Screed
Part#: TVSA-H

1.6 HP Honda GX35 Engine
Aluminum Magnesium blades available from 8ft - 14ft
Finish concrete 4X faster than other screed methods
360° adjustable handle placement
3 Year Engine Warranty & 1 Year Product Warranty



6" Early Entry Green Concrete Saw
Part#: TFS6H

5.5 HP Honda GX160 Engine
Maximum cutting depth of 1 3/16 inches
OSHA compliant vacuum port for dust collection
Includes 6" early entry concrete blade
3 Year Engine Warranty & 1 Year Product Warranty

GENERATORS



2000 Watt Inverter Generator
Part#: TG2000i

2000 Max Watts, 1600 Rated Watts
Run Time of 8 hours on 1 gallon of gas
OSHA and GFCI Compliant
Parallel technology capable for double the power
2 Year Product Warranty



3500 Watt Inverter Generator
Part#: TG3500i

3500 Max Watts, 3000 Rated Watts
Run Time of 20 hours on 3.5 gallon of gas
OSHA and GFCI Compliant with Electric Start
Parallel technology capable for double the power
2 Year Product Warranty



4000 & 7000 Watt Generators
Part#: TG4000 & TG7000

4000 / 7000 Max Watts, 2500 / 5500 Rated Watts
Voltage Selector gives Full Wattage for 120V or 240V
Run Time of 8 hours at 50% Load
OSHA and GFCI Compliant
2 Year Product Warranty

HAVE QUESTIONS?

Contact us. *We're here to help!*

Email us at sales@tomahawk-power.com



WELDING / POWER

INVERTER SERIES



120 Amp Portable Welder Generator
Part#: TWG120A

Steady 120 Amp DC welding output
60% Duty Cycle for extended use
Suitable for welding rods from 6010 to 6013
Includes wheel kit for job site portability
2 Year Product Warranty

INVERTER SERIES



210 Amp Portable Welder Generator
Part#: TWG210A

Steady 50 - 210 Amp DC welding output
60% Duty Cycle for extended use
Suitable for welding rods from 6010 to 7024
Electric Key Start with battery included
2 Year Product Warranty



9000 Watt Generators
Part#: TG9000

9000 Max Watts, 8500 Rated Watts
Run Time of 10 hours at 50% Load
7 gallon fuel tank for extended use
Electric Key Start with battery included
2 Year Product Warranty

PEST CONTROL



3.7 Gallon 3HP Backpack Fogger
Part#: TMD14

Turbo Boosted Pump with 40ft + Horizontal Reach
Sprays 1 acre in 30 minutes
10X Faster than Manual Pump Sprayers
Converts to Leaf Blower with 200 MPH Air Velocity
1 Year Engine Warranty & 1 Year Product Warranty



5 Gallon 1.8HP Backpack Sprayer
Part#: TPS25

Reach Up to 30ft Horizontal Reach
Sprays 1 acre in 15 minutes
10X Faster than Manual Pump Sprayers
450 PSI Commercial Grade Pump
1 Year Engine Warranty & 1 Year Product Warranty



4 Gallon 3HP Backpack Spreader
Part#: TGS30

Reach Up to 30ft Horizontal Reach
Covers 1 acre in less than 30 minutes
20X Faster than Manual Broadcast Spreaders
Converts to Fogger with Liquid Tank Accessory
1 Year Engine Warranty & 1 Year Product Warranty

AND MORE



HONDA ENGINES

8" Gas Powered Concrete Scarifier
Part#: TSCAR8H

5.5 HP Honda GX160 Engine
Remove traffic lines at 800 - 1,000 linear ft/hr
Tungsten Carbide Blade Kit Available
OSHA approved dust port for silica vacuum removal
3 Year Engine Warranty & 1 Year Product Warranty

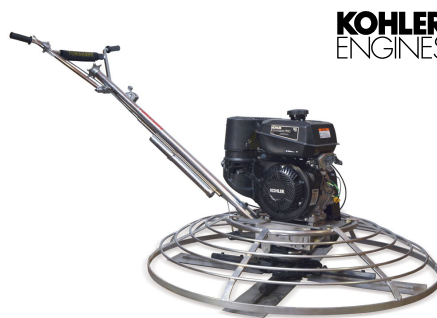

KOHLER ENGINES

36" & 46" Concrete Power Trowel
Part#: TPT36K & TPT46K

6 HP Kohler CH260 & 14 HP Kohler CH440 Engines
Adjust trowel blade pitch from 0-28°
60-115 RPM rotor speed for superior concrete finishes
Includes float pan and trowel blades
3 Year Engine Warranty & 1 Year Product Warranty



2" and 3" Trash Water Pumps
Part#: TW2 & TW3

Moves liquids at a rate up to 9,240 gallons/hour
Handle solids up to 0.6"
Cast iron impeller for smooth performance
6.5 HP engine protected by rugged all purpose frame
1 Year Product Warranty

ASSEMBLED IN THE
USA
PARTS SOURCED GLOBALLY

(866) 577-4476

www.tomahawk-power.com



Power Your World

Tomahawk understands to keep a job-site running smoothly the proper equipment and spare parts are needed at the drop of a hat. With same day shipping and faster delivery times, count on Tomahawk to keep you powered throughout the day! With long lasting parts and engines, Tomahawk equipment will be the star of your fleet for years to come. Visit www.tomahawk-power.com to get started today!

TOMAHAWK

Tomahawk Power, LLC
San Diego, CA

Sales Support

(866) 577-4476
sales@tomahawk-power.com

Equipment Support

(866) 577-4476
support@tomahawk-power.com

www.tomahawk-power.com

