







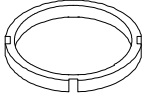
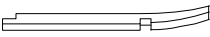

SWIVEL BARSTOOL
 (NR104851-FBS-HS
 NR104852-FCS-HS
 NR104853-FBS-DI
 NR104854-FCS-DI
 NR1048FB-05AW
 NR1048FC-06AW)

ASSEMBLY INSTRUCTIONS
 1 OF 2

DO NOT TIGHTEN SCREWS UNTIL COMPLETELY ASSEMBLY!

PART LIST		
A	 SEAT	1 PC
B	 FRAME	1 PC
C	 ROUND STRETCHER	1 PC
D	 LEG	4 PCS

HARDWARE		
1	 LONG BOLT 1/4" x 12 x 1-3/8"	16 PCS
2	 SPRING WASHER 1/4" x 10D x 1.1mm	20 PCS
3	 FLAT WASHER 1/4" x 19D x 2mm	20 PCS
4	 ALLEN KEY 2-1/4" x 4mm	1 PC
5	 SHORT BOLT 1/4" x 12 x 3/4"	4 PCS
6	 SWIVEL BASE	1 PC

Step 1

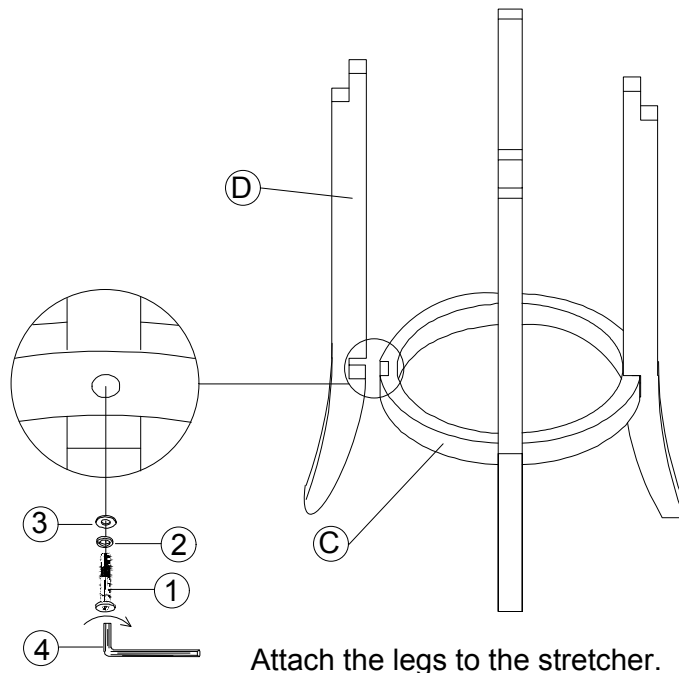

SWIVEL BARSTOOL
(NR104851-FBS-HS
NR104852-FCS-HS
NR104853-FBS-DI
NR104854-FCS-DI
NR1048FB-05AW
NR1048FC-06AW)

ASSEMBLY INSTRUCTIONS
2 OF 2

DO NOT TIGHTEN SCREWS UNTIL COMPLETELY ASSEMBLY!

Step 2

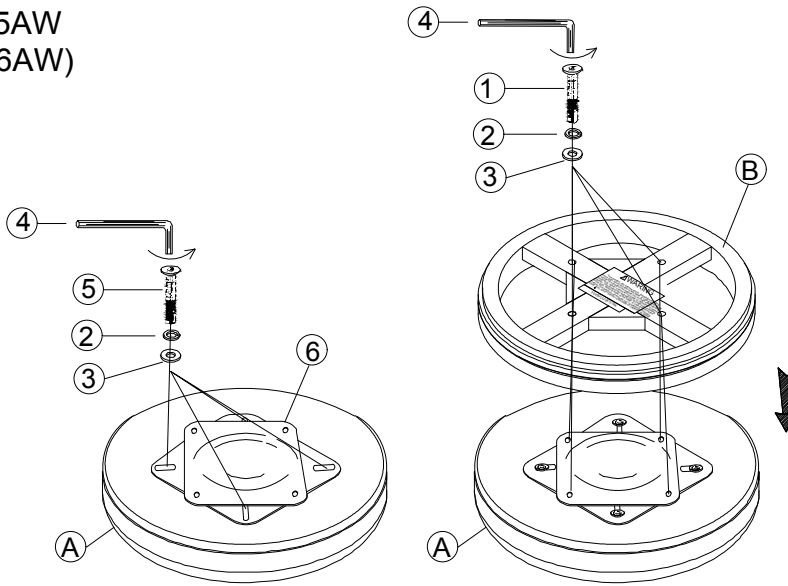

Attach the swivel to the seat and the frame.
Please note that long holes on the swivel go toward the seat
and the holes with inserts go away from the seat.

Step 3

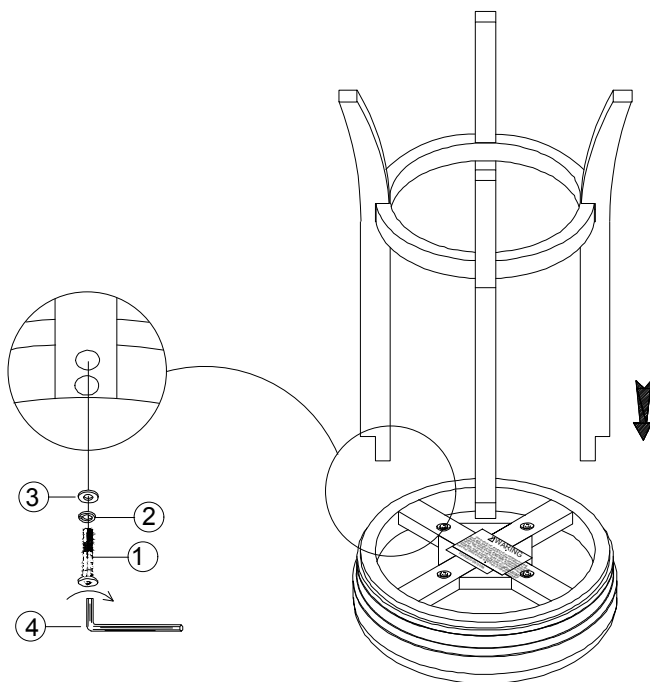

Attach the legs to the frame.

Complete

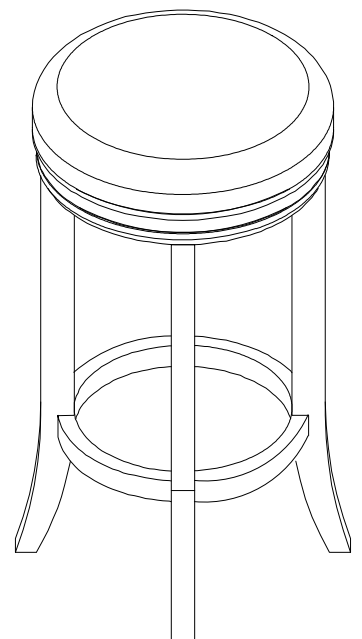

Please tighten all screws.
Assembly is complete.