

Earthquake®

GROUNDBREAKING POWER EQUIPMENT

Illustrated Parts Breakdown
 Illustration des pièces détachées

**Model Number,
 Numéros de modèle :**
38040

ENGLISH

FRANÇAIS

S/N

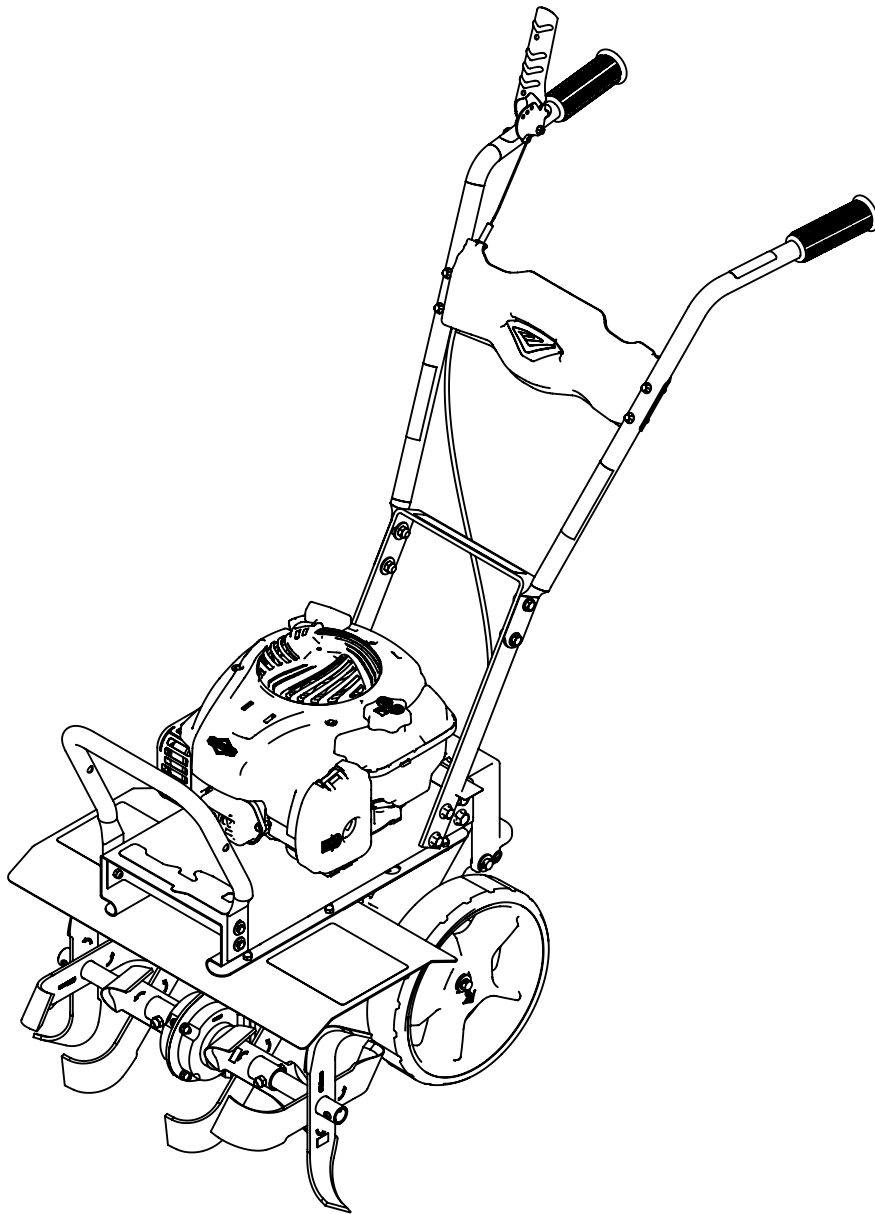

www.getearthquake.com - (800) 345-6007

© 2021 Ardisam, Inc.
 All Rights Reserved
 Tous droits réservés
 P/N: 38442
 SVC: SVC05516
 ECN: 13299
 REV 1: 2021-05-20



THIS INSTRUCTION BOOKLET CONTAINS IMPORTANT SAFETY INFORMATION. PLEASE READ AND KEEP FOR FUTURE REFERENCE.
 CE LIVRET D'INSTRUCTIONS CONTIENT DES INFORMATIONS IMPORTANTES SUR LA SÉCURITÉ. VEUILLEZ LE LIRE ET LE CONSERVER POUR TOUTE CONSULTATION EXTÉRIEURE.

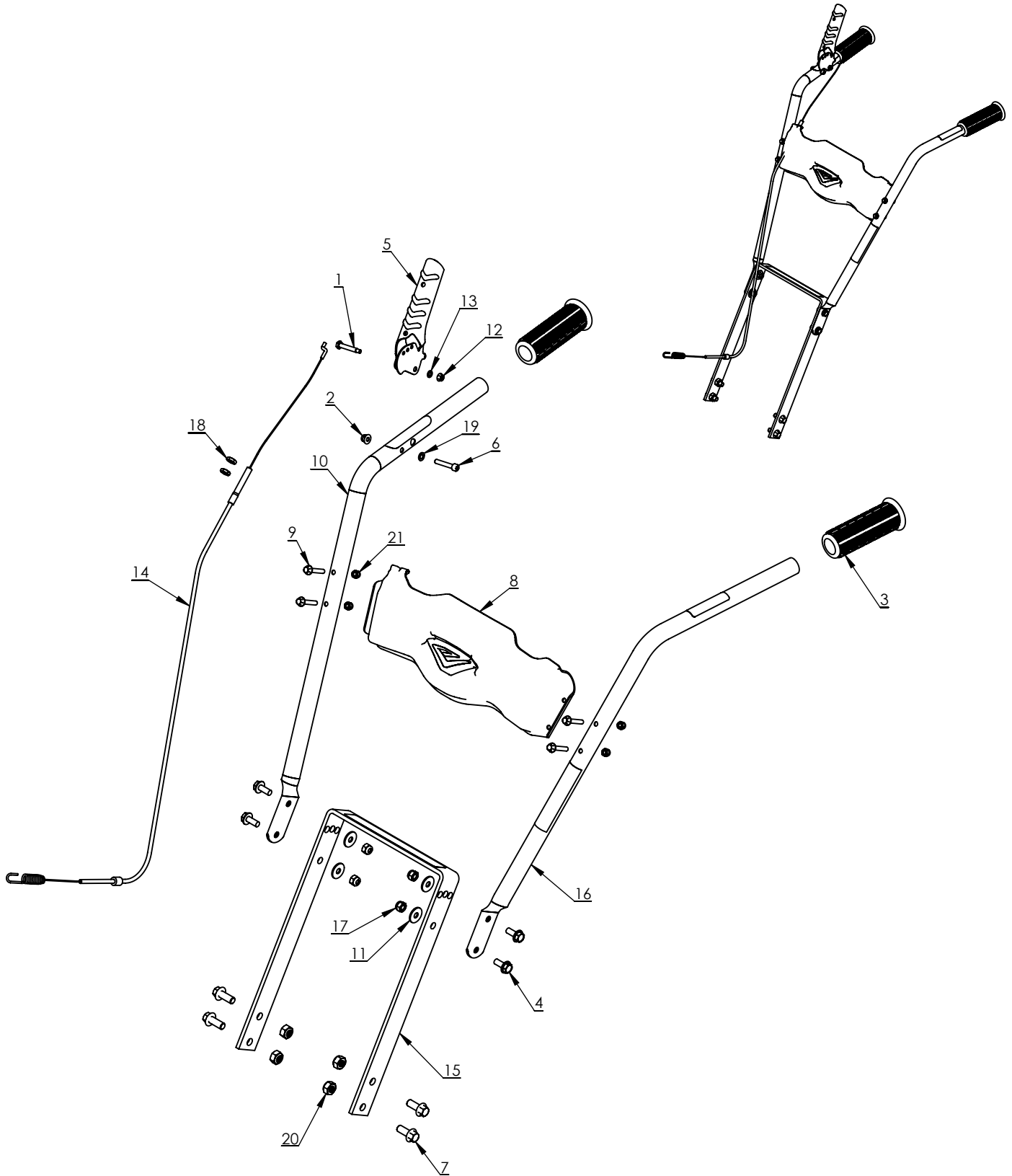

REF./ REP.	PART NO. /° RÉF.	DESCRIPTION	QTY. /QTÉ
1	13159	SHOULDER BOLT M5X0.8X7 6X32MM	1
2	13599	NUT M6X1.0X9.1 MM HFNYLK CL8 ZN	1
3	13833	HANDLE GRIP TEXTURED	2
4	13906	SERRATED FLANGE BOLT M8X1.25X20 MM	4
5	14902	LEVER CLUTCH RIGHT HAND BLACK	1
6	20347	SOCKET BOLT M6X1.0X35 MM BLACK	1
7	20819	SERRATED FLANGE BOLT M10X1.5X25 MM	4
8	28216	RED DASH PANAL WITH CHROME BADGE	1
9	28473	FLANGE BOLT M6X1.0X35 MM	4
10	30289	RIGHT HANDLEBAR BLACK	1
11	3245	WASHER M8X24 MM	4
12	3248	NUT M5X0.8X5 MM HFNYLK GR8.8 ZN	1
13	3308	WASHER M5X10 MM	1
14	34701	CABLE 1200.5 MM LONG	1
15	39760	MOUNT HANDLEBAR WITH DECAL	1
16	39761	LEFT HANDLEBAR WITH DECALS	1
17	400023	NYLOCK NUT M8X1.25 MM	4
18	4620	JAM NUT M8X1.25 MM	2
19	W1200117	WASHER M6X12 MM	1
20	W1265V0903	NYLOCK NUT M10X1.5 MM	4
21	W1265V0913	NYLOCK NUT M6X1.0 MM	4

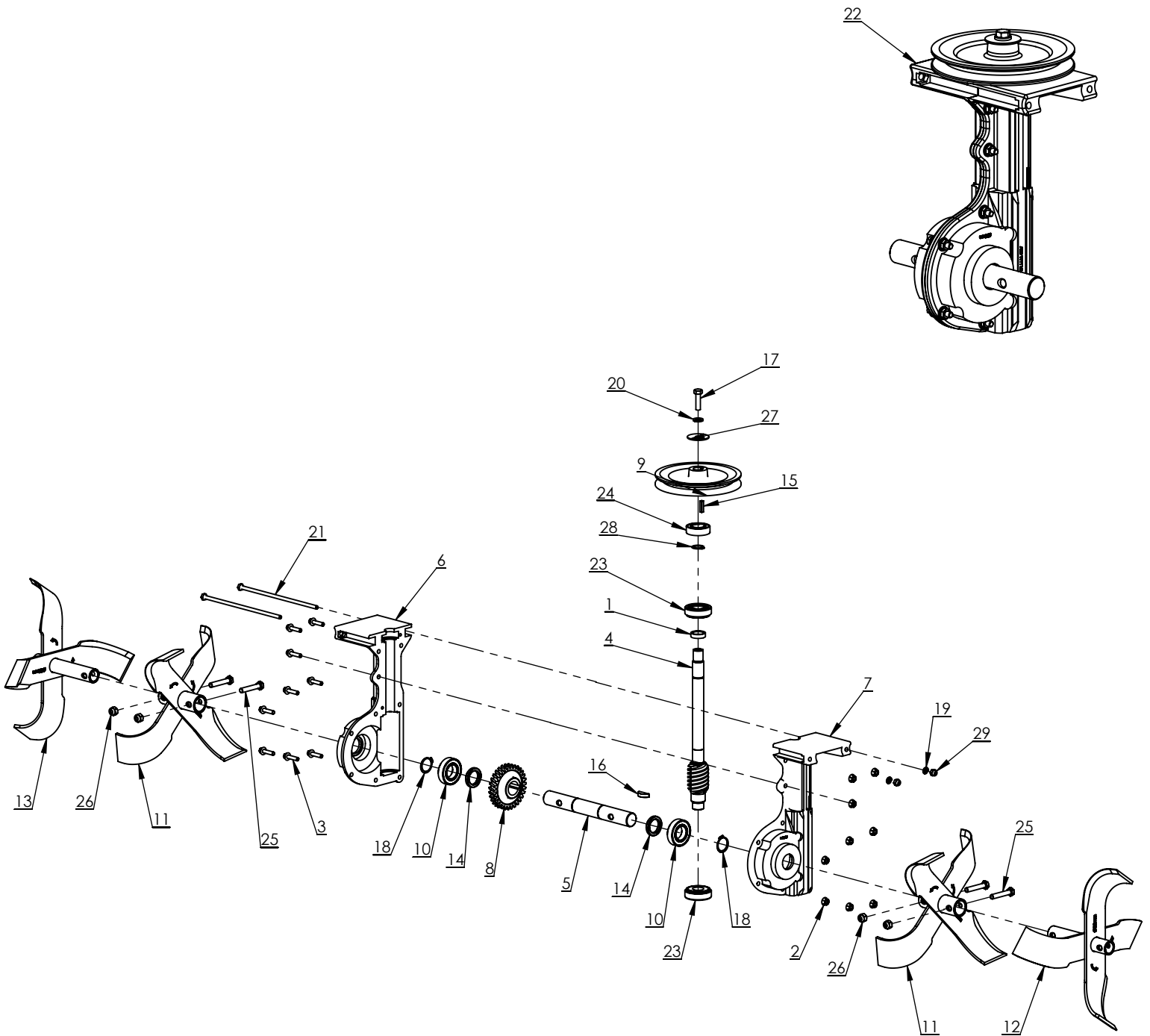

REF./ REP.	PART NO. /° RÉF.	DESCRIPTION	QTY. /QTÉ
1	13590	ROUND STEEL SPACER 26 X 20.22 X 6.8MM	1
2	13599	NYLOCK FLANGE NUT M10 X 1.5 MM	9
3	13600	FLANGE BOLT M5 X 0.8 X 12 MM GOLD	9
4	13610	WORM DRIVESHAFT	1
5	13612	TINE SHAFT 25MM OD 6MM KEYWAY	1
6	13613	TRANSMISSION CASE RIGHT	1
7	13614	TRANSMISSION CASE LEFT	1
8	13615	GEAR BRONZE 25MM ID 6MM KEY 30 TEETH	1
9	13619	TRANSMISSION PULLEY SINGLE GROOVE	1
10	13902	BALL BEARING 25MM ID	2
11	13903	TINE SET INSIDE	2
12	13904	TINE SET OUTSIDE LEFT	1
13	13905	TINE SET OUTSIDE RIGHT	1
14	14421	SPACER 25 X 35 X 5.43 MM	2
15	17989	KEY 5 X 5 X 20 MM	1
16	17990	WOODRUFF KEY 6 X 10 X 25MM	1
17	17991	BOLT M8 X 1.25 X 30 MM	1
18	1810	SNAP RING 1 INCH EXTERNAL	2
19	18130	SPRING LOCK WASHER M6 X 11.8 MM	2
20	1916965	SPRING LOCK WASHER 3/8 IN	1
21	20824	BOLT M6 X 1.0 X 190 MM	2
22	25021	TRANSMISSION COMPLETE ASSEMBLY	1
23	3220	BEARING 20 X 47 X 15.2 TAPERED ROLLING	2
24	3309	BEARING 20MM ID 42 MM OD	1
25	3316	BOLT M8 X 1.25 X 45 MM	4
26	400023	NYLOCK NUT M8 X 1.25 MM	4
27	803	WASHER 5/16 X 1-1/2 IN	1
28	8924	RING RETAINING EXTERNAL 3/4 INCH	1
29	W1265V0913	NYLOCK NUT M6 X 1.0 MM	2

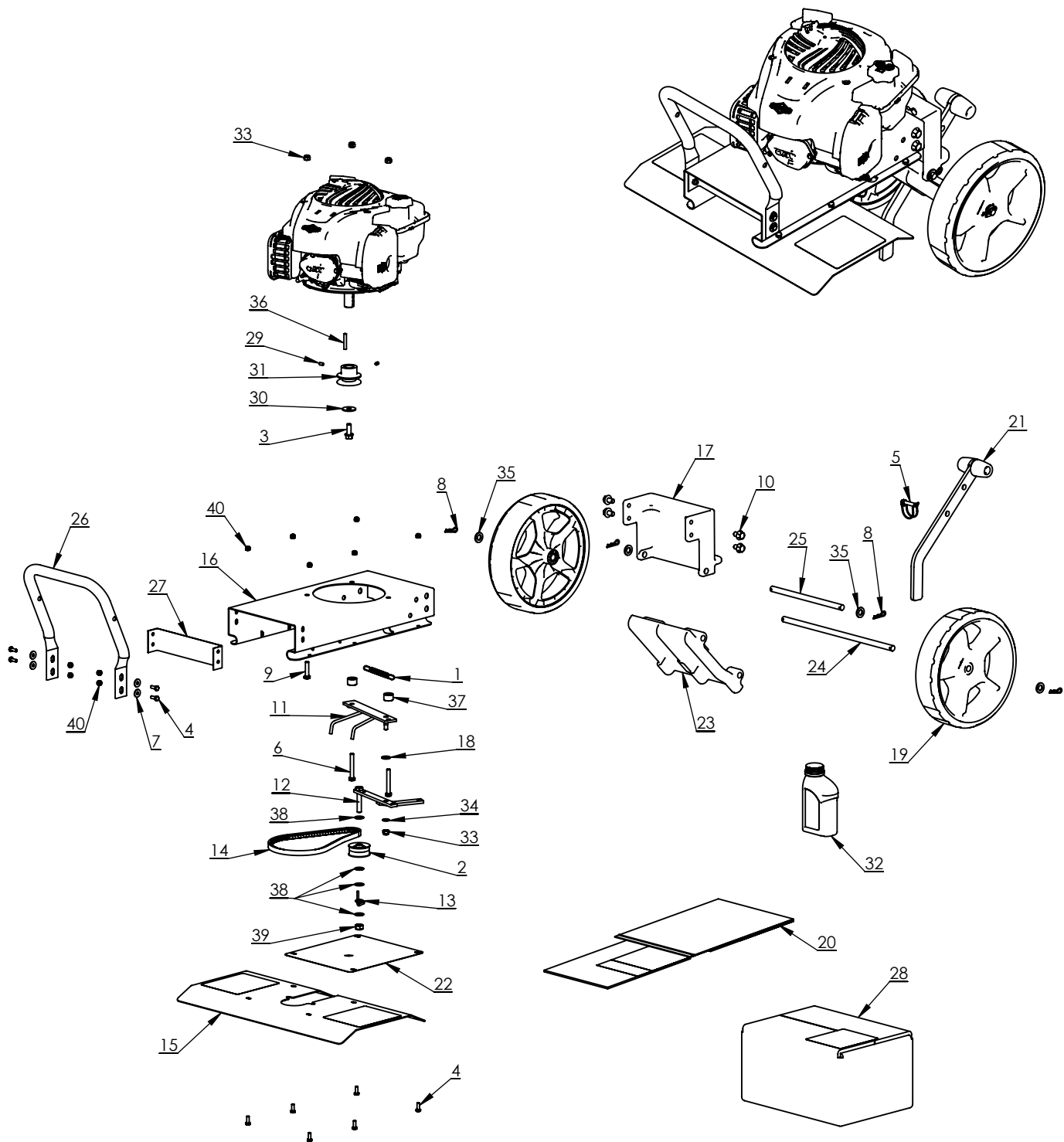

REF./ REP.	PART NO. /° RÉF.	DESCRIPTION	QTY. /QTÉ
1	1407	SPRING EXTENSION WIRE 2 HOOK	1
2	1413	PULLEY IDLER REVERSE	1
3	16510	FLANGE BOLT 3/8-24X1IN	1
4	17986	BOLT M6 X 1.0 X 16 MM	10
5	18039	LOCK PIN 8MM X 40 MM YELLOW	1
6	20144	BOLT M8 X 1.25 X 60 MM	2
7	20148	WASHER M6 X 18.8 MM	4
8	20173	COTTER HAIRPIN 2.5 MM DIA. X 35 MM	4
9	20816	BOLT M8 X 1.25 X 35 MM	1
10	20820	FLANGE BOLT M10 X 1.5 X 16 MM	4
11	20834	BELT GUIDE AND MOUNT	1
12	20835	FORWARD ARM	1
13	22563	BELT CATCH WIREFORM	1
14	22633	BELT V 4L 12 X 675 TOOTH	1
15	23560	TINE SHIELD WITH DECALS RED	1
16	23580	ENGINE FRAME WITH DECAL RED	1
17	23583	TAIL UPPER WITH DECAL RED	1
18	2431	WASHER M10 X 20 MM	1
19	28532	WHEEL GRAY 5-SPOKE PLASTIC	2
20	31049	PARTS BAG MANUAL AND HARDWARE	1
21	31056	DRAG STAKE T-HANDLE	1
22	3275	FRAME SHIELD	1
23	3330	TAIL MOUNT LOWER	1
24	3331	WHEEL SHAFT	1
25	3332	SHAFT TAIL PIVOT	1
26	3335	LOWER HANDLEBAR	1
27	3371	FRAME END COVER	1
28	34723	BOX TINE AXLE DRAG STAKE BADGER	1
29	36492	SET SCREW M6 X 1.0 X 10 MM BLACK	2
30	37894	WASHER 3/8 X 1-1/4 IN	1
31	38245	ENGINE PULLEY	1
32	38480	OIL 4 CYCLE 14 FL OZ	1
33	400023	NYLOCK NUT M8 X 1.25 X 9.5 MM	4
34	400024	WASHER M8 X 16 MM	1
35	50175	WASHER 13.30 X 24.0 MM	4
36	723	KEY SQUARE 3/16 X 1-1/2 IN	1
37	744	SPACER 10.5 X 22.0 X 14.5 MM	2
38	W1200126	WASHER M10 X 21.25 MM	4
39	W1265V0903	NYLOCK NUT M10 X 1.5 X 8.4 MM	1
40	W1265V0913	NYLOCK NUT M6 X 1.0 X 8 MM	10



GROUNDBREAKING POWER EQUIPMENT

1160 Eighth Avenue
PO Box 666
Cumberland, WI 54829

Phone, Téléphone: (800) 345-6007
Fax, Télécopieur: (715) 822-2124
www.getearthquake.com