

BASE-CLAMPS HOW IT WORKS:

STEP 1

Select the right size clamp
(Various sizes sold
separately)

STEP 2

Select the base & ring
clamp that coincides with
what you need to mount
2A. Use protective film to
prevent any paint
damage **2B.**

STEP 3

Lock it in place

The self locking clamp design
allows for easy one person
installation. Simply slip the clamp
over tube and lock in your base,
secure using the stainless
mounting hardware and you are
ready to Mount Up and Move Out.

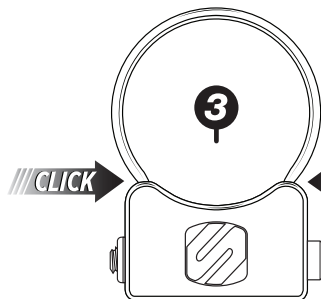
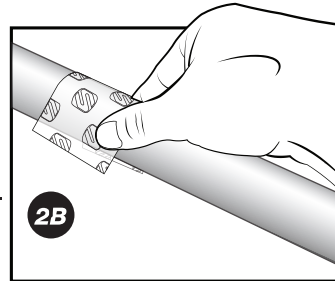
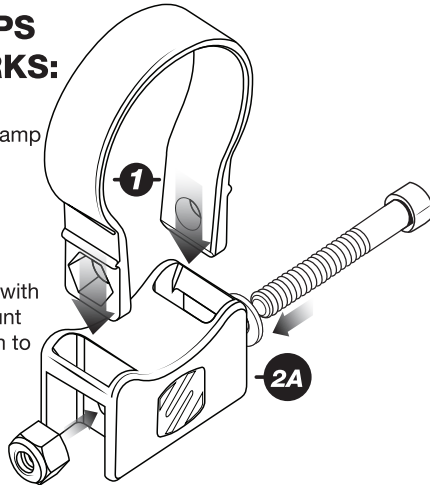

NOTE: Ring clamps 2" & over in size may
require pre-stretching to help spread the
clamp over the tube. (Use Protective film
when mounting)

Register your product online at

www.scosche.com/register

SCOSCHE

PSM21004
PSM21005

STRAP BASE

PSM21004*

PARTS INCLUDED
(1) Small Strap Base

PSM21005*

PARTS INCLUDED
(1) Large Strap Base

TOOLS REQUIRED (Not Included)

3/16" Hex (Allen) Key, Except where noted

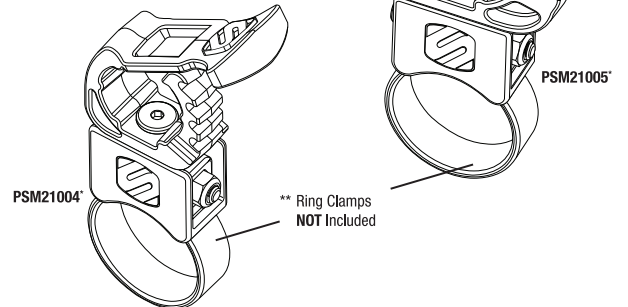

* Each Sold Separately

**Tube clamp ring NOT included, see available size clamps below.

VARIOUS RING CLAMP SIZES SOLD SEPARATELY w/ HARDWARE**

PSC21006 - BaseClamp 1.5" Ring Clamp
PSC21007 - BaseClamp 1.625" Ring Clamp
PSC21009 - BaseClamp 1.75" Ring Clamp
PSC21010 - BaseClamp 1.85" Ring Clamp
PSC21011 - BaseClamp 1.875" Ring Clamp
PSC21012 - BaseClamp 2" Ring Clamp

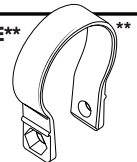

For complete warranty details, please visit us at
www.scosche.com or call (800) 363-4490



IMPORTANT!

DO NOT RETURN PRODUCT TO THE RETAILER

IF YOU NEED ASSISTANCE OR REPLACEMENT PARTS

CALL US TOLL FREE: 1-800-363-4490 x1

HOURS MON-FRI 8AM-5:30PM (PST) SATURDAY 8AM-2PM (PST)

PSM21004 / PSM21005

SMALL/ LARGE STRAP BASE

INSTRUCTIONS

STEP 1

Choose a mounting location (A).

STEP 2

Position & mount Soft Tool Mount, Small/Large, base to the appropriate sized clamp ring for the vehicle by clicking clamp rings into the base (B)*. Then use a 3/16" hex key to fasten the screw & nut included with the clamp ring. Continue until clamp is tight and does not move.

Note: Do not exceed 200 inch-pounds.

STEP 3

Use the rubber pull strap to secure the object. Make sure the pull tab is securely engaged into the 'teeth' of the tool mount base (D).

Note: The rubber clamp can rotate about as needed. No need to loosen or otherwise adjust the pivot screw (E).

WARNING!

Do not over stretch or exceed the mounting capacity on the strap

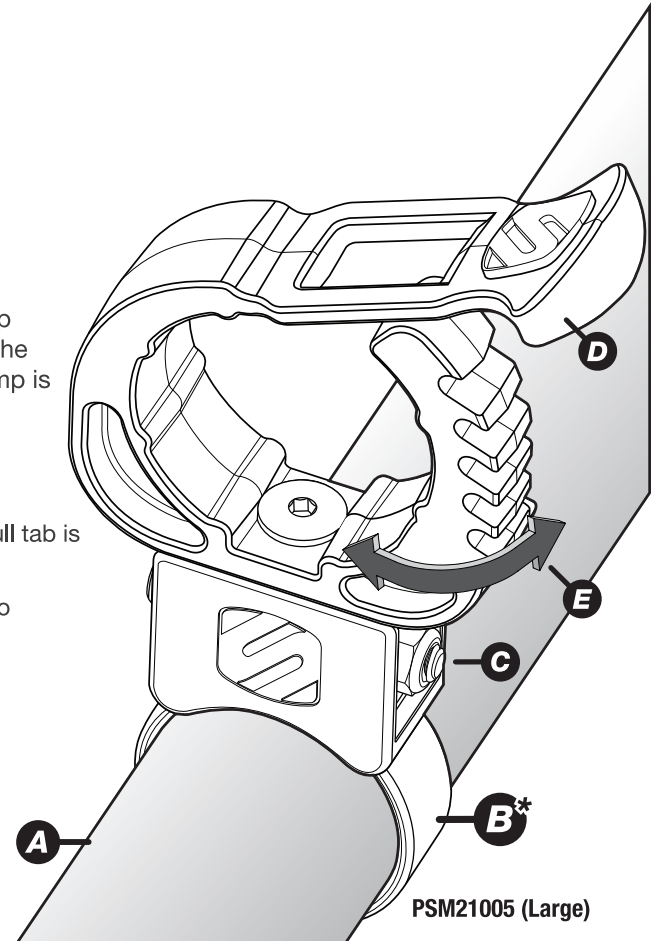
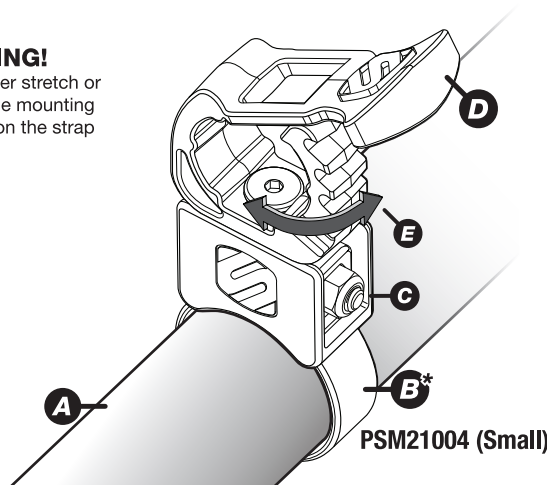

Clamp Removal:

In-order to remove the tube clamp from location, the clamp must first be tightened to allow base removal. Once tightened, loosen the clamp and carefully squeeze clamp to remove from the location.

Note: Use protective film to help avoid damage to the paint.

*Various ring clamp sizes available (sold separately w/ hardware).