

## BASE-CLAMPS HOW IT WORKS:

### STEP 1

Select the right size clamp  
(Various sizes sold  
separately)

### STEP 2

Select the base & ring  
clamp that coincides with  
what you need to mount  
**2A.** Use protective film to  
prevent any paint  
damage **2B.**

### STEP 3

Lock it in place

The self locking clamp design  
allows for easy one person  
installation. Simply slip the clamp  
over tube and lock in your base,  
secure using the stainless  
mounting hardware and you are  
ready to Mount Up and Move Out.

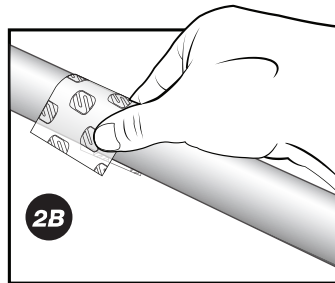
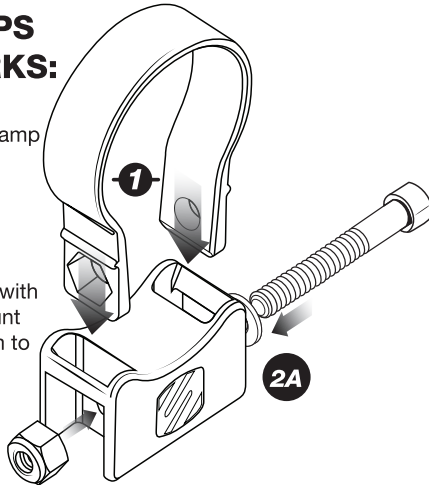

**NOTE:** Ring clamps 2" & over in size may  
require pre-stretching to help spread the  
clamp over the tube. (Use Protective film  
when mounting)

For complete warranty details, please visit us at  
[www.scosche.com](http://www.scosche.com) or call (800) 363-4490

Register your product online at

[www.scosche.com/register](http://www.scosche.com/register)

**SCOSCHE**

PSM21007

## VERTICAL WHIP MOUNT

### PARTS INCLUDED

(1) Vertical Whip Mount (Fixed)

### TOOLS REQUIRED (Not Included)

3/16" Hex (Allen) Key, Except where noted

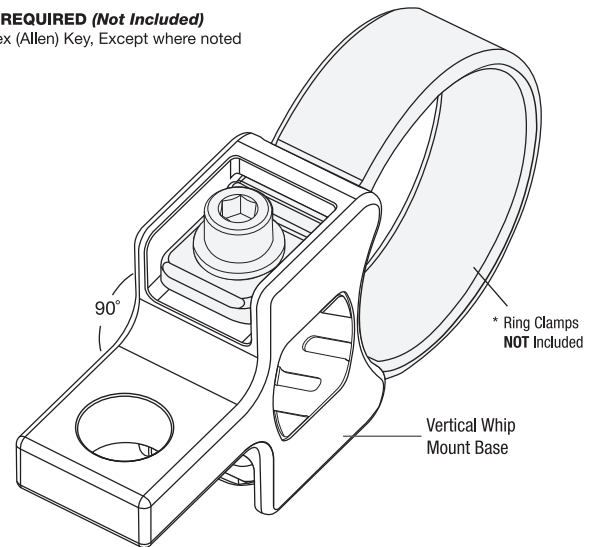

### VARIOUS RING CLAMP SIZES SOLD SEPARATELY w/ HARDWARE\*

- PSC21006 - BaseClamp 1.5" Ring Clamp
- PSC21007 - BaseClamp 1.625" Ring Clamp
- PSC21009 - BaseClamp 1.75" Ring Clamp
- PSC21010 - BaseClamp 1.85" Ring Clamp
- PSC21011 - BaseClamp 1.875" Ring Clamp
- PSC21012 - BaseClamp 2" Ring Clamp

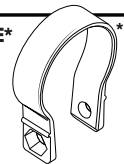

## IMPORTANT!

**DO NOT RETURN PRODUCT TO THE RETAILER**

IF YOU NEED ASSISTANCE OR REPLACEMENT PARTS

CALL US TOLL FREE: 1-800-363-4490 x1

HOURS MON-FRI 8AM-5:30PM (PST) SATURDAY 8AM-2PM (PST)

# PSM21007

## VERTICAL WHIP MOUNT (90°)

### INSTRUCTIONS

#### STEP 1

Choose a mounting location (A).

#### STEP 2

Position & mount Adjustable Whip Mount base to the appropriate sized clamp ring for the vehicle by clicking clamp rings into the base (B\*). Then use a 3/16" hex key to fasten the screw & nut included with the ring clamp (C). Continue until clamp is tight and does not move.

**Note:** Do not exceed 200 inch-pounds.

#### STEP 3

Mount whip as per manufacturer's instructions.

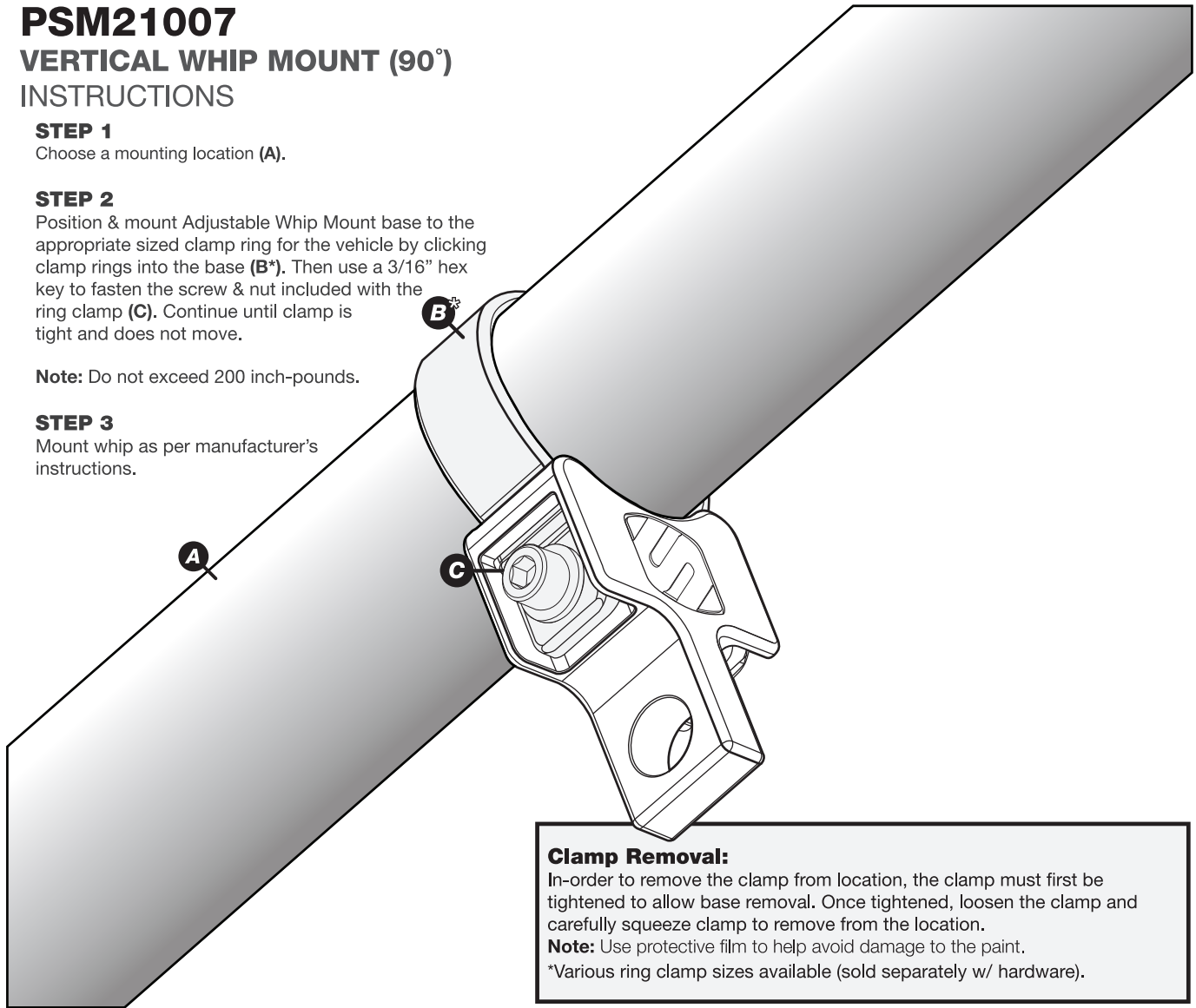

#### Clamp Removal:

In-order to remove the clamp from location, the clamp must first be tightened to allow base removal. Once tightened, loosen the clamp and carefully squeeze clamp to remove from the location.

**Note:** Use protective film to help avoid damage to the paint.

\*Various ring clamp sizes available (sold separately w/ hardware).