

Assembly Instruction

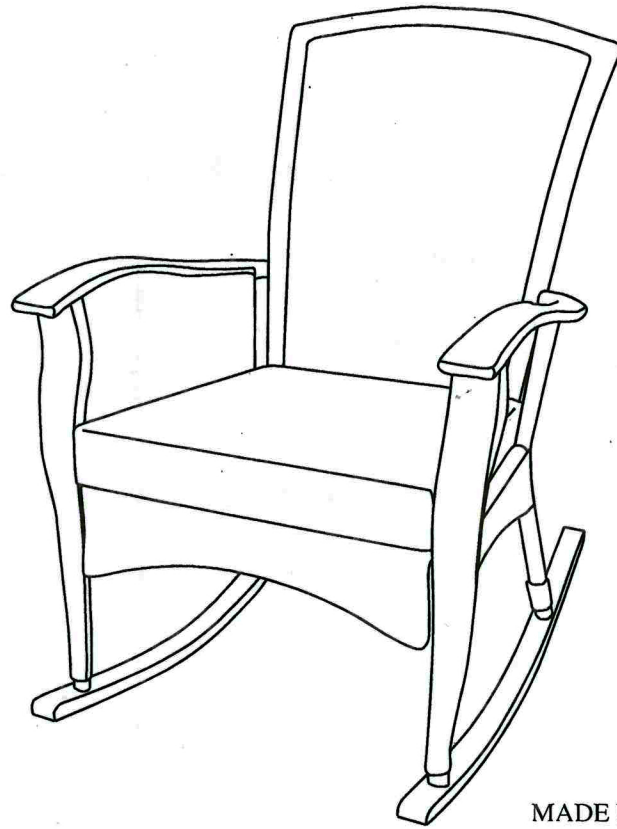



Resin Wicker Rocker

with Cushion



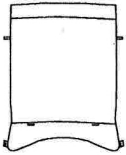

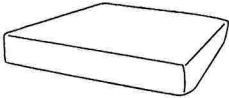

MADE IN CHINA

PARTS LIST:

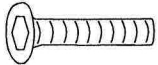

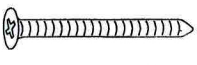
<p>(A) Back Qty: 1</p> 	<p>(B) Right Side Qty: 1</p> 	<p>(C) Left Side Qty: 1</p> 	<p>(D) Seat Qty: 1</p> 
<p>(E) Runners Qty: 2</p> 	<p>(F) Runners Qty: 1</p> 		

HARDWARE LIST:

<p>1. Bolt Qty: 2</p> 	<p>2. Nut Qty: 8</p> 	<p>3. Washer Qty: 8</p> 	<p>4. Screw Qty: 4</p> 
<p>5. Wrench Qty: 1</p> 	<p>6. Hex Wrench Qty: 1</p> 		

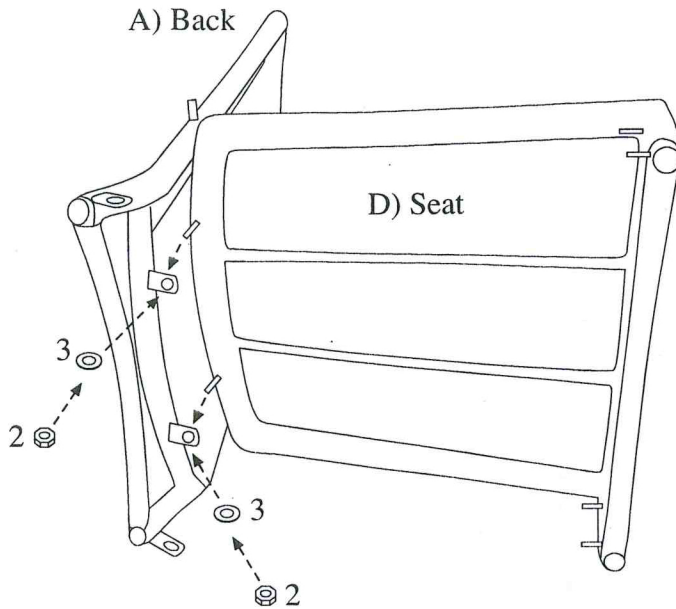

Step 1 Note: Wait to fully tighten the Nuts and Bottls until they have all been inserted in the last step. Two people might be required to align holes for fasteners.



Item	Drawing	Qty
2		2
3		2

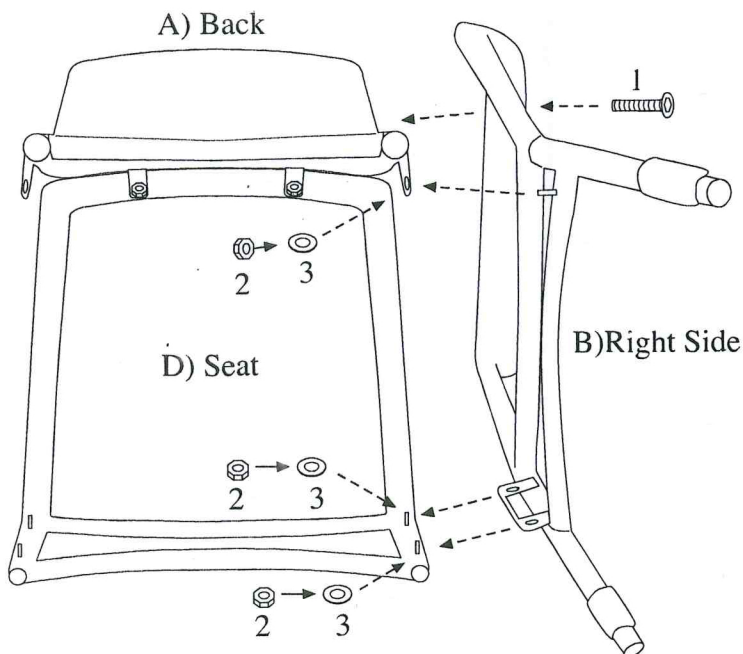

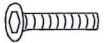
Step 2

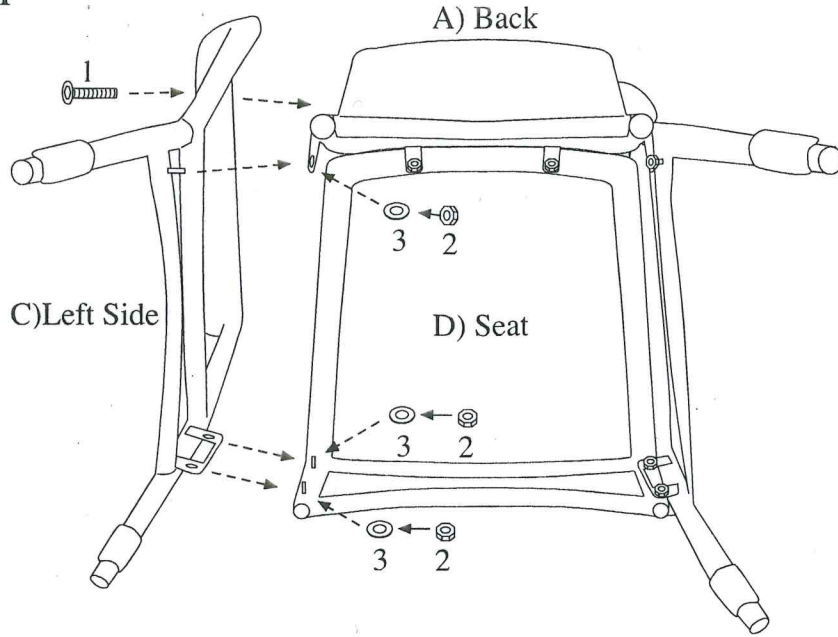

Item	Drawing	Qty
1		1
2		3
3		3

Step 3



Item	Drawing	Qty
1		1
2		3
3		3

Step 4

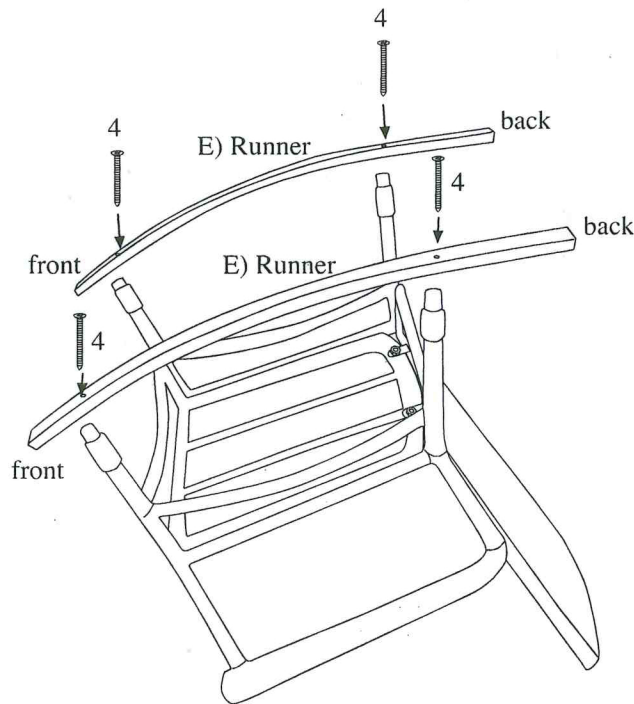

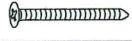
Item	Drawing	Qty
4		4

Step 5

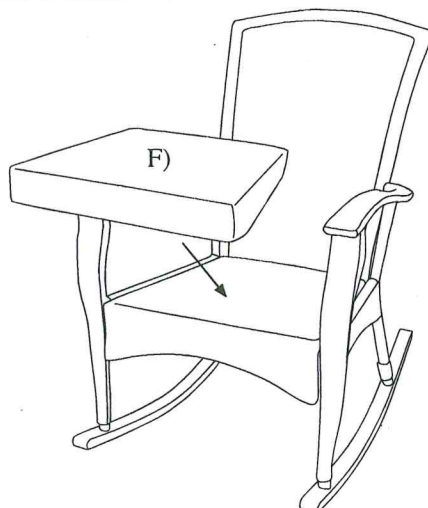

**** BE SURE ALL FASTENERS ARE FULLY TIGHTENED BEFORE SITTING ON THE ITEM**