

Assembly Instructions

Round Table

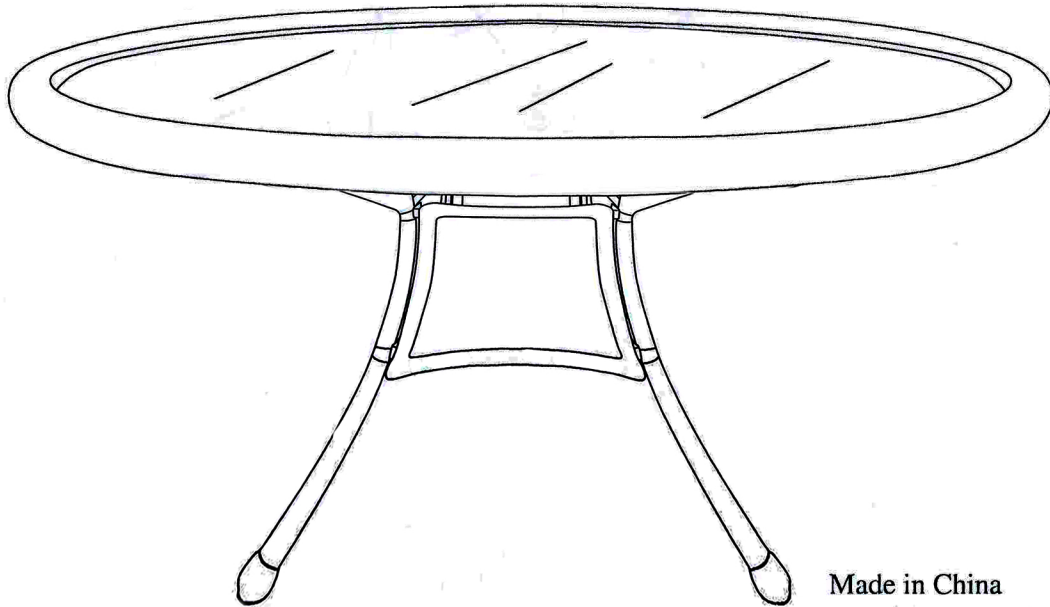
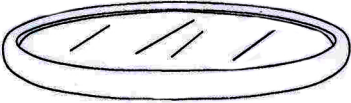
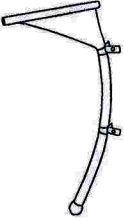
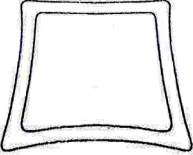

PARTS LIST:

(A) Glass Table Top Qty: 1	(B) Leg Qty: 4	(C) Panel Qty: 4
		

HARDWARE LIST:

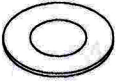
1. Nut Qty: 16	2. Washer Qty: 16
	

Step 1 Note: Do not fully tighten fasteners until all parts are attached in the last step.

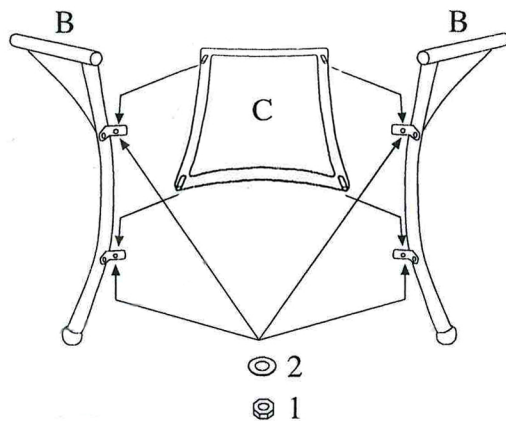

Step 2

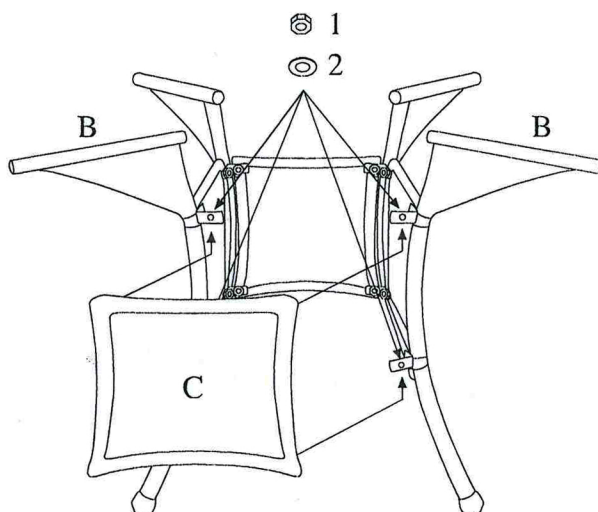

Step 3

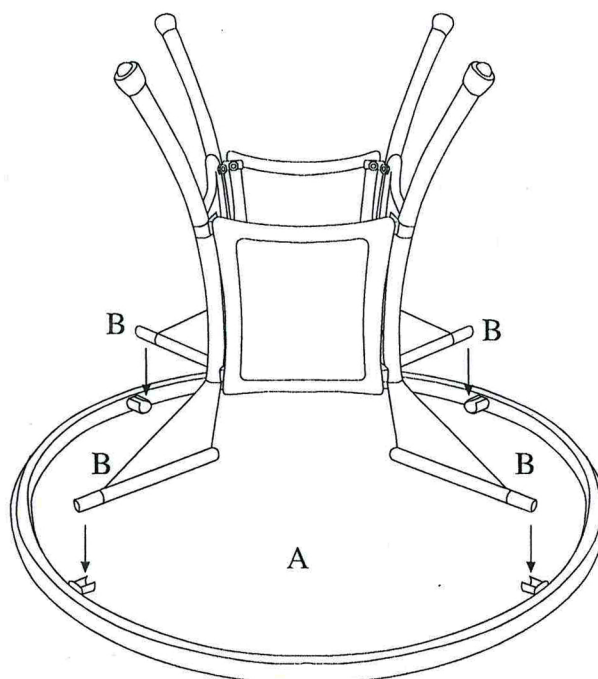

**** BE SURE ALL FASTENERS ARE FULLY TIGHTENED BEFORE USING THE ITEM.**