



XPOWER MANUFACTURE, INC.

220 Clary Ave., San Gabriel, CA 91776

PH: 626-285-3301 FAX: 626-285-3302

Email: info@xpower.ws Website: xpower.ws

COMMERCIAL DEHUMIDIFIER

XD-125

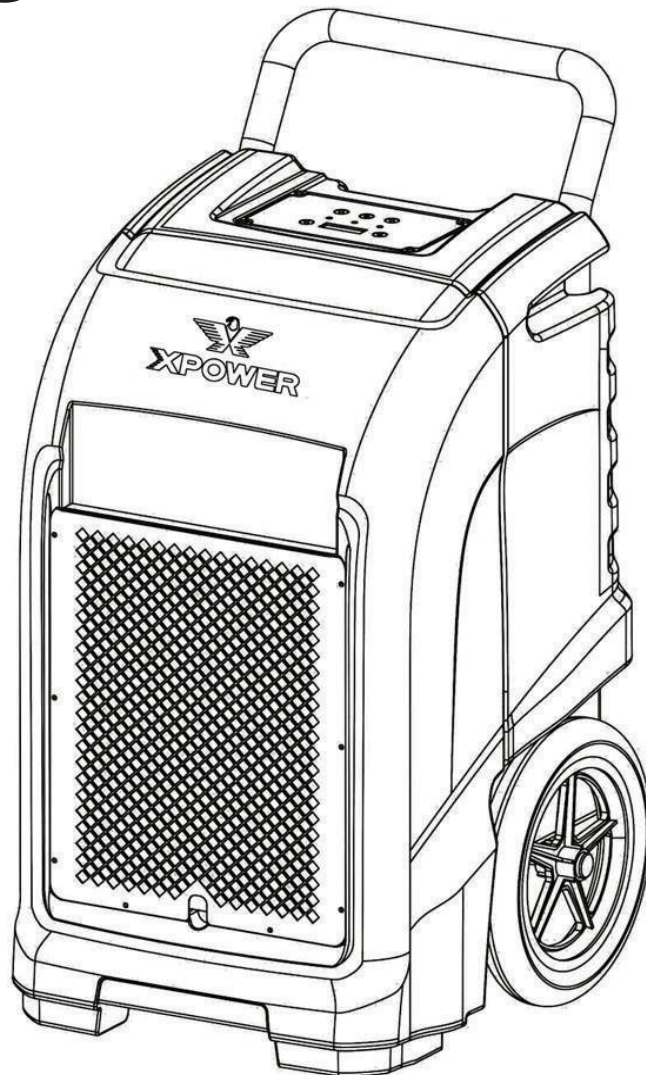

OWNER'S MANUAL



PLEASE READ AND SAVE THESE INSTRUCTIONS

Table of Contents

INTRODUCTION.....	2
SAFETY INSTRUCTIONS.....	3
ASSEMBLY & PARTS	4
SET UP/OPERATION	5
CONTROL PANEL.....	6
CARE & MAINTENANCE.....	7
- Cleaning the Air Filter	7
- Replacing the Battery	7
TROUBLESHOOTING.....	8
APDS-I.....	9
WARRANTY	10

INTRODUCTION

The XPOWER XD-125 dehumidifier is a professional drying tool designed to maximize water extraction in a variety of temperature and humidity conditions. Perfect for water damage restoration jobs as well as other industrial applications; the XD-125 offers programmable humidity for optimal environment control.

- Advanced Digital Control Panel
- Efficient Motor
- Semi-Pneumatic Wheels
- Auto Water Pump Drain Hose
- Compact Design
- Highly Durable Construction

Model # XD-125 SPECIFICATIONS	
WATER REMOVAL CAPACITY	125 pints/day (90°F, 90% RH)
	76 pints/day at AHAM (80°F, 60% RH)
TYPE	Standard Refrigerant (R410A)
VOLTS/HERTZ	115V/60Hz
POWER	7.3 AMPS
AIRFLOW	235 CFM
OPERATING RANGE	33°-100°F
UNIT WEIGHT/DIMENSIONS (WxDxH)	81 lbs. / 20" x 19" x 32"
COMPRESSOR TYPE	High Efficiency Rotary Compressor
DRAIN HOSE LENGTH	20 ft.
POWER CORD LENGTH	25 ft.
FILTER	High Airflow Filter (HAF)
HOUSING CONSTRUCTION	Roto-Mold Polyethylene
WHEELS	Shock Absorbing Semi-Pneumatic
DEFROST TYPE	Hot-Gas Bypass
SAFETY CERTIFICATION	ETL/CETL Certified

SAFETY INSTRUCTIONS

WARNING! - TO REDUCE RISK OF FIRE, ELECTRIC SHOCK OR INJURY TO PERSONS OR PROPERTY:

1. Always operate the product from a power source of the same voltage, frequency and rating as indicated on the product identification plate.
2. Close supervision is necessary when any product is used by or near children, the elderly, or the infirm. Do not allow children to use the appliance as a toy.
3. Do not operate this product with a damaged power cord plug. If the supply cord is damaged it must be replaced by a qualified personnel or other similar qualified persons in order to avoid hazard.
4. To reduce the risk of electrical shock, do not expose the unit or flexible cord to moisture of any kind.
5. Switch off and unplug from the power socket when not in use, before assembling or before cleaning.
6. Do not place objects on the product or allow objects to obstruct the inlet or outlet openings, or operate in close proximity to walls, curtains, etc.
7. The use of attachments or accessories not recommended or sold by the product distributor may cause injury to persons or damage to property.
8. This product is intended for normal light commercial use only.
9. Do not attempt to dismantle the appliance.
10. Do not operate the appliance on a metal surface.
11. Do not use the appliance in artificially hot or humid conditions, or allow it to be used in any other hazardous environment.
12. Do not clean the appliance with organic solvent.
13. This appliance is not intended for use by persons (including children) with reduced physical, sensory or mental capabilities or lack of experience and knowledge unless they have been given supervision or instruction concerning use of the appliance by a person responsible for their safety.
14. This instruction manual is an integral part of the appliance. It should be stored for safe keeping and must always accompany the appliance in the event of ownership transfer or for reference to by a service engineer.

 WARNING DO NOT OBSTRUCT THE AIR INLET OR OUTLET

READ AND SAVE THESE SAFETY INSTRUCTIONS

ASSEMBLY & PARTS

1. Your XD-125 Dehumidifier is fully assembled with the exception of the handle
2. Using a Phillips screwdriver, loosely attach each screw to unit. **DO NOT TIGHTEN** until all six screws have been fastened. (*You will experience some resistance as screws fit into housing).
3. Alternate diagonally between screws when tightening to ensure the best fit.

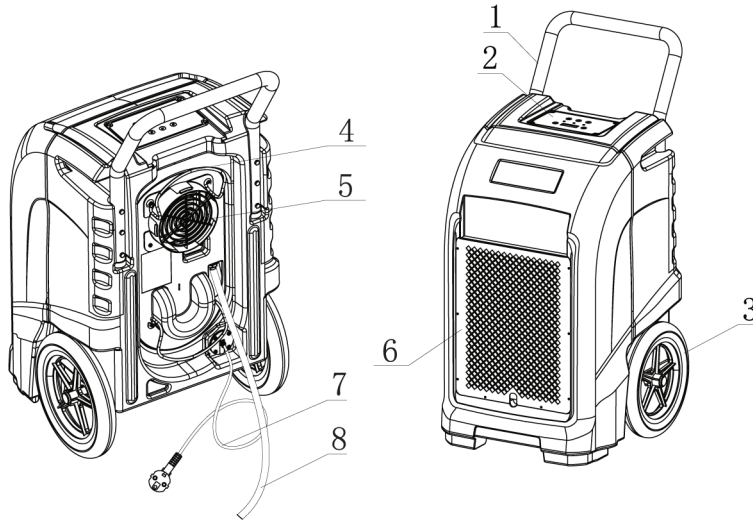

- | | |
|--------------------------|---------------------|
| 1. Metal Handle | 5. Air Outlet Grill |
| 2. Control Panel | 6. Air Inlet Grill |
| 3. Semi-Pneumatic Wheels | 7. Power Cord |
| 4. Water Hose Bracket | 8. Water Hose |

DO NOT dispose of any packaging until you have confirmed the appliance is operational. After removing the packaging, ensure the contents are intact and complete. In the unlikely event of missing parts, contact your retailer.

DRAINAGE OPTION:

When drying extremely humid spaces, a plastic pipe with a diameter larger than 6.7" can be attached to the hood as shown for faster purging.

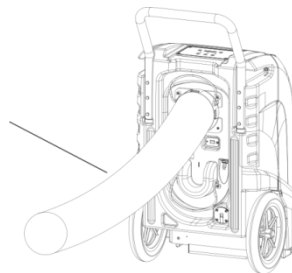

SET UP/OPERATION

READ ALL INSTRUCTIONS TO PREVENT SYSTEM DAMAGE



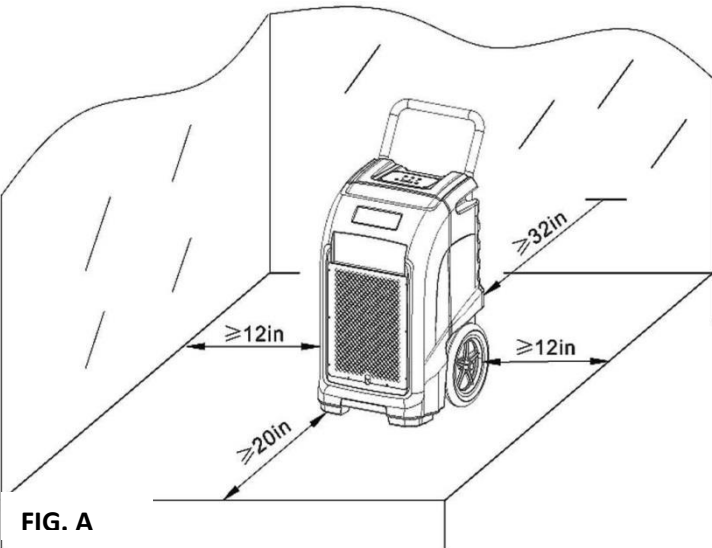

- For proper operation, DO NOT obstruct the air inlets/outlets, or drainage hose.
- WAIT 30 minutes after transporting unit to jobsite before switching ON to allow refrigerant system to stabilize
- DO NOT switch the power OFF by disconnecting power cord
- WAIT at least three minutes after turning the power OFF to move unit.

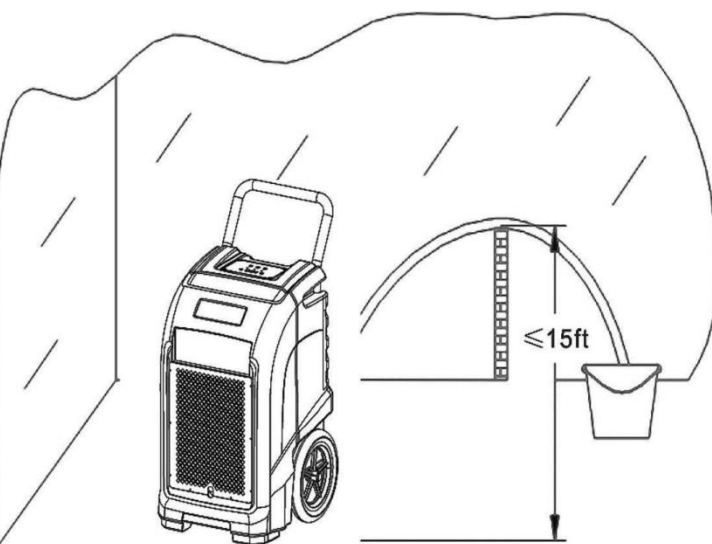

- Always operate unit in an enclosed area, closing all doors, windows and other pathways open to external areas for maximum water removal efficiency
- Keep traffic through drying area to a minimum
- Place the dehumidifier in the center of the room away from walls and furnishings. (Fig. A)
- Uncoil entire drainage hose on rear of unit. Place open end of hose into a drain, bucket, or outdoors. Ensure drainage hose is not restricted or kinked. **DO NOT** elevate hose higher than 15 ft. above unit. (Fig B)
- Take care that water does not create a slip hazard. If using a collection bucket check water level regularly.



BASIC OPERATION GUIDE

1. Press  button to turn unit ON (*30 second delay is normal if recently powered off)
2. Display shows Preferred Humidity Setting on Left and Current Humidity on Right
3. Adjust  and  to set preferred humidity level (90% to 26%)
4. Unit will run automatically, turning on and off to maintain desired humidity level
5. To run continuously press  to below 26% until "CO" displays
6. Once job is complete, press  button to turn the unit off. The water pump will automatically purge for 40 seconds to drain.

CONTROL PANEL



1. POWER (ON/OFF)
2. DISPLAY
3. UP AND DOWN CONTROLS
4. PURGE
5. TIME

1. **ON/OFF:** Power button turns the unit ON or OFF
2. **DISPLAY:** Left hand side indicates adjustable preferred humidity level, right side indicates current humidity. See #5 for reading time.
3. **AND** : Set to adjust humidity ranging from 90% to 26%.
*By pressing key to below 26%, "CO" displays, confirming setting to run the machine *continuously*.
4. **PURGE:** Press to empty water from the pump reservoir. During normal operation the pump purges automatically when reservoir is full (indicator light will illuminate). ALWAYS purge before moving machine to avoid water spillage. The pump automatically purges for forty seconds after turning unit off.

5. **TIME:**

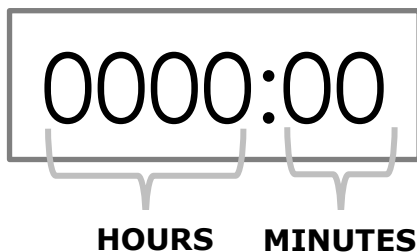

- Press "T" once to display current job working time.
- To **reset** working time for new job hold "T" down for 5 seconds.
- Press "T" twice (within 10 seconds) to display the total working hours for the life of the machine. *This time cannot be reset. It will start again from zero if total time exceeds display space.

INDICATOR LIGHTS:

- **Purging:** Light illuminates to indicate when unit is purging either automatically or after selecting manual purge button.
- **Defrosting:** Flashing light indicates unit is defrosting. Once defrost is complete the unit begins to dehumidify again automatically.
- **Running:** Light illuminates to confirm unit is plugged into an active power source.

Key Lock Function: Press both "T" and "P" for 2 seconds at the same time. Defrost light will illuminate to confirm the control panel is locked. Unlock by performing the same function.

CARE & MAINTENANCE

- Cleaning the Air Filter

Regular cleaning of filters is highly recommended. The performance of the dehumidifier will be greatly reduced if the filters become blocked.

1. Confirm the dehumidifier is turned OFF and the plug is disconnected from power outlet
2. Remove the filter as shown in the diagram.
3. Using a vacuum hose and nozzle, vacuum any debris from the filter.
4. Wash with warm water and a mild detergent and allow to air dry.
5. Once the filter is fully dried, re-install.

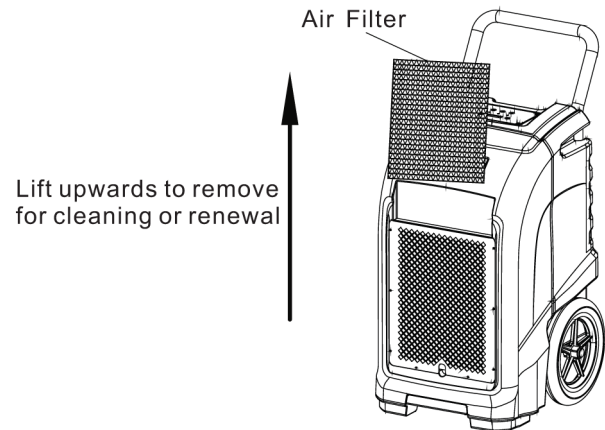

- Replacing the Battery

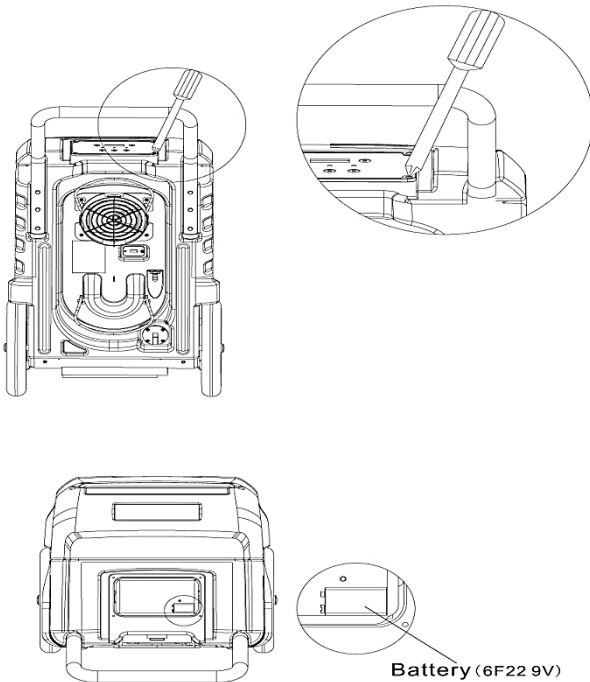

1. Confirm unit is turned OFF and plug is disconnected.
2. Remove the screws in the four corners of the control panel.
3. Once the screws are removed, carefully lift the control panel to access the PCB.
4. On the PCB is a 6F22 9V battery. Remove the battery and replace.
5. Align the control panel back on the PCB.
6. Reinstall the four screws.

TROUBLESHOOTING

WARNING! UNPLUG & POWER OFF BEFORE PERFORMING ANY MAINTENANCE

PROBLEM	CAUSE	SOLUTION
Dehumidifier does not operate	No power to appliance	Check connection to power source. "Running" indicator light should flash green if unit is connected to a functional power source.
	Switch not turned on	Press  to switch on
	E4 error is displayed	Check drainage hose for blockages
Dehumidifier collects little water	Insufficient working time	Allow more working time
	Filter is blocked	Clean filter
	Low ambient temperature	Increase ambient temperature
	Condensation hose is blocked	Check hose for restrictions
Dehumidifier is operating but room is not drying	Doors and windows are open	Seal room from external areas

ERROR CODES

ATTENTION! CONTACT A QUALIFIED SERVICE AGENT FOR REPAIRS IN THE EVENT OF ERROR CODES

CODE	E1	E2	E3	E4
Error Message	Coil sensor error	Humidity sensor error	Low or no refrigerant	Water pump fault or blockage

APDS-I

(sold separately)

Uses combined power of XPOWER Air Scrubber (X-3500) and Dehumidifier to remove moisture and contaminants from the air.

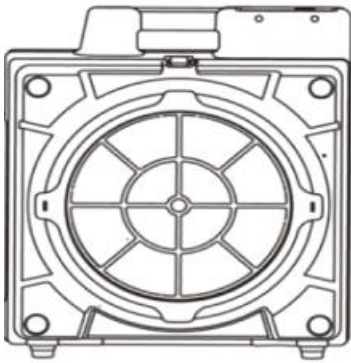

(X-3500)
Air Scrubber



(8DH15)
Ducting Hose



(ASK125)
Air System Adapter

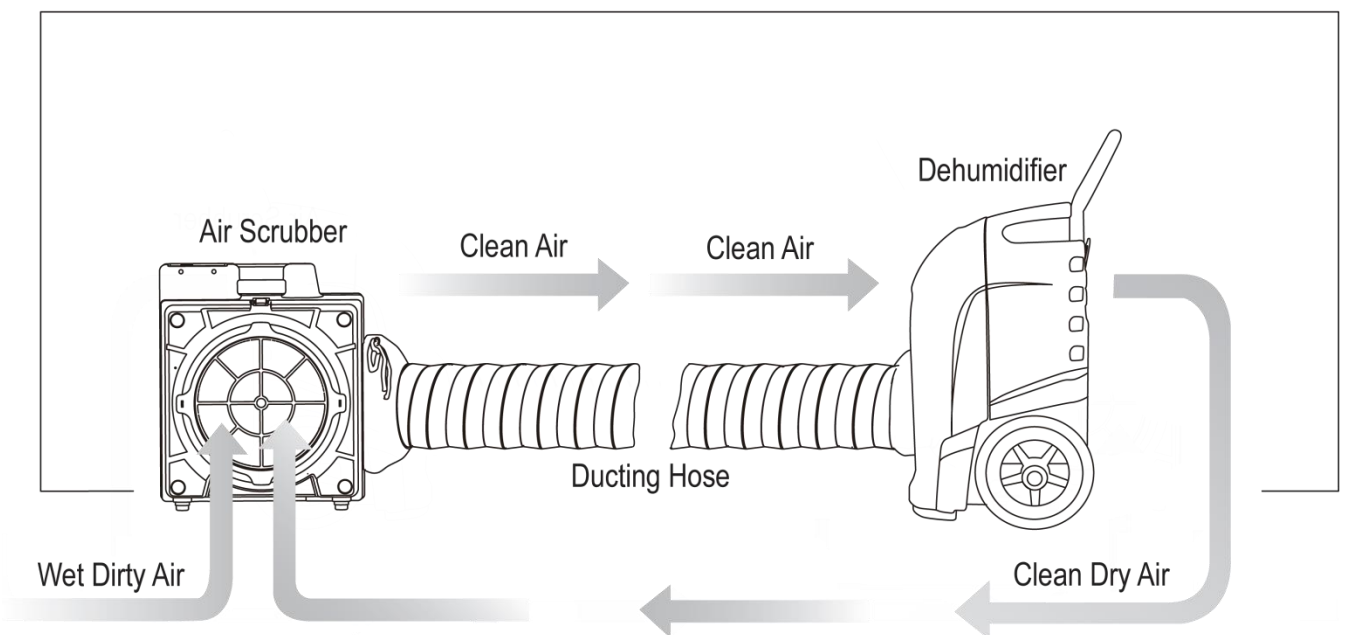

WARRANTY

XPOWER 1 Year Limited Warranty covers the unit from defects in materials and craftsmanship. The Warranty covers normal use for a term of one year from the original date of purchase including parts, labor and one way shipping.

Warranty does not cover signs of misuse including, but not limited to, a unit that has been dropped, subjected to water damage, tampered with, improper voltage use and unauthorized maintenance and repairs. The POWER CORD and FILTERS are not covered by the warranty.

Service

In order to receive service or replacement parts under warranty, you must:

- Call XPOWER Customer Service at 855-855-8868 or 626-285-3301 for a Return Merchandise Authorization (RMA) number and return instructions.
- Have original proof of purchase.
- Use original packaging or Industrial certified packaging method.

The end user will be responsible to ship the unit (with the RMA number showing on the shipping label) to the XPOWER Service Department. Upon inspection, we will advise you of the repairs needed and the cost (if applicable). XPOWER will provide repair or replacement parts depending on warranty.

This warranty applies only while this appliance is used in the United States.

WARRANTY REGISTRATION

Please complete and mail or fax for your product warranty. For a multiple units, please list serial numbers on a separate sheet of paper. Address: XPOWER MANUFACTURE, INC. 220 Clary Avenue San Gabriel, CA 91776, USA
Tel: (626) 285-3301; Fax: (626) 285-3302

Company Name / Contact Person / Title _____	
Address _____	City _____
State / Province _____	Zip _____ Country _____
Phone _____	Fax _____ E-mail _____
Model # _____	Serial #: _____
Date of Purchase ____/____/____	Purchased From _____
Additional Comments / Suggestions _____	