

Groundbreaking Power Equipment

Illustrated Parts Breakdown
Illustration des pièces détachées

**Model Number,
Numéros de modèle :**
31285

ENGLISH
FRANÇAIS

S/N

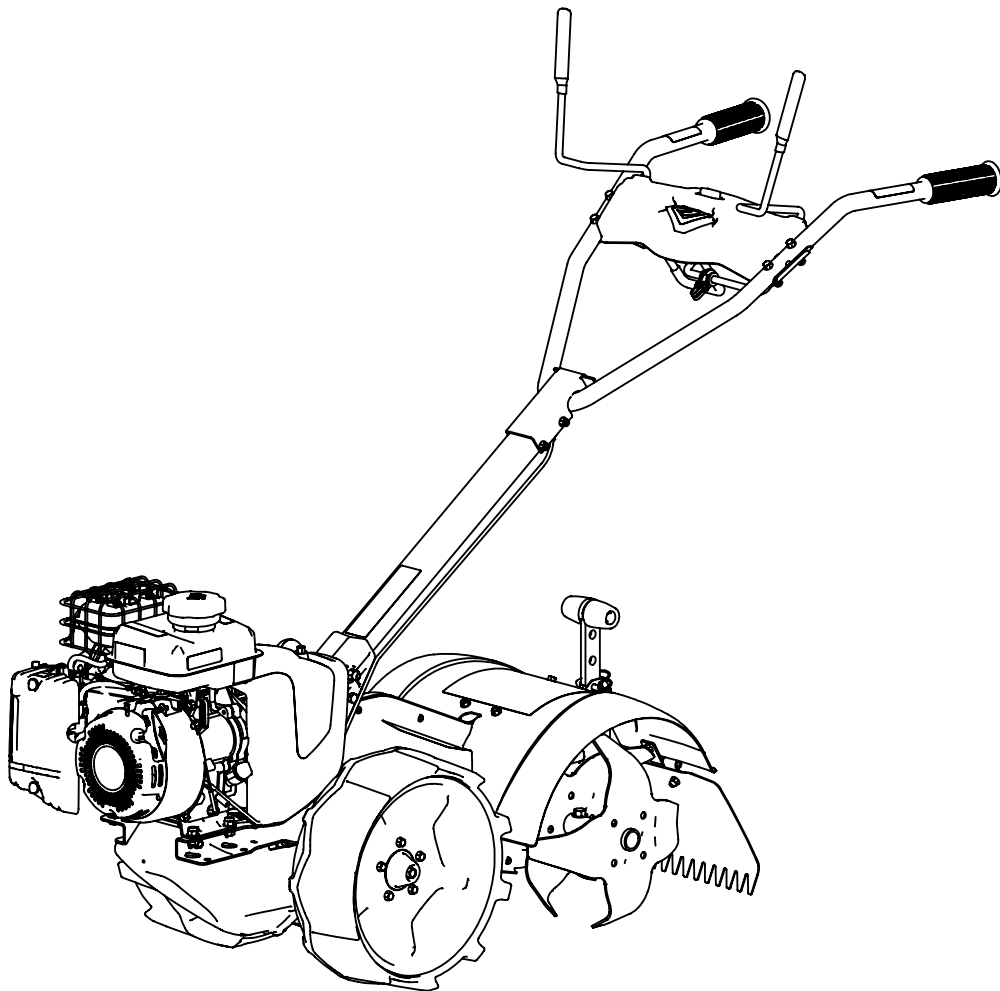

© 2021 Ardisam, Inc.
All Rights Reserved
Tous droits réservés
P/N: 36814
SVC: 05486
ECN: 13183
REV 1: 2020-10-28



www.getearthquake.com - (800) 345-6007



THIS INSTRUCTION BOOKLET CONTAINS IMPORTANT SAFETY INFORMATION. PLEASE READ AND KEEP FOR FUTURE REFERENCE.
CE LIVRET D'INSTRUCTIONS CONTIENT DES INFORMATIONS IMPORTANTES SUR LA SÉCURITÉ. VEUILLEZ LE LIRE ET LE CONSERVER POUR TOUTE CONSULTATION EXTÉRIEURE.

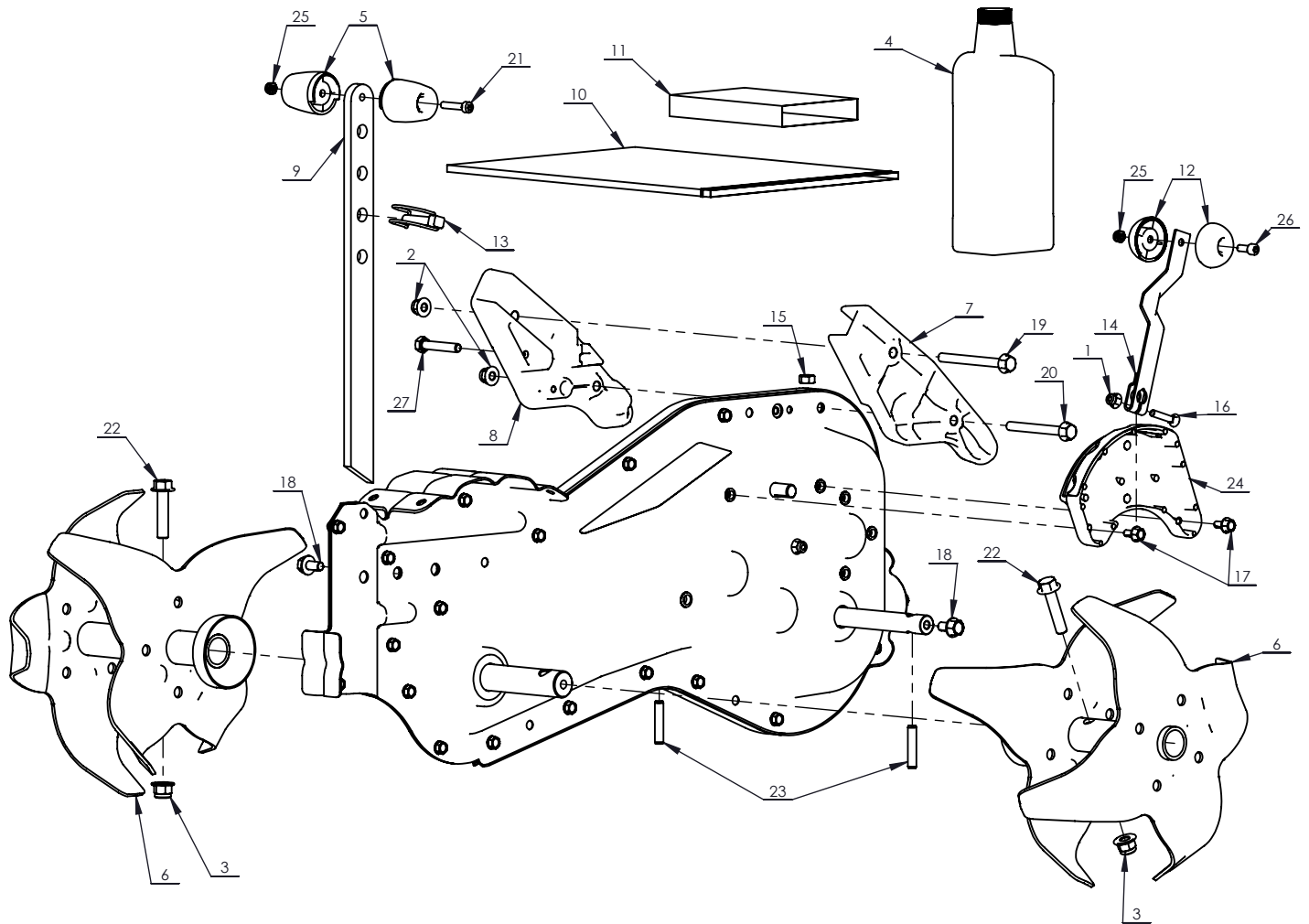

REF./REP.	PART NO./° RÉF.	DESCRIPTION	QTY./QTÉ
1	14109	FLANGE LOCK NUT M6X1.0	1
2	16400	FLANGE LOCK NUT M8X1.25	2
3	16903	FLANGE LOCK NUT M10X1.5	2
4	20164	OIL 10W-30 1 QT	1
5	28210	DRAG STAKE HANDLE GREEN	2
6	31122	TINE GREY	2
7	31143	HANDLEBAR MOUNT RIGHT RED	1
8	31144	HANDLEBAR MOUNT LEFT RED	1
9	31227	DRAG STAKE BLACK	1
10	31413	MANUAL BAG	1
11	31414	HARDWARE PARTS BAG	1
12	31495	SHIFTER LEVER HANDLE GREEN	2
13	31563	LOCK PIN M8	1
14	31626	SHIFTER ARM	1

REF./REP.	PART NO./° RÉF.	DESCRIPTION	QTY./QTÉ
15	3252	NUT M8X1.25	1
16	34028	CARRIAGE BOLT M6X1.0X30 MM	1
17	34141	FLANGE BOLT M6X1.0X14 MM	2
18	34142	FLANGE BOLT M8X1.25X16 MM	2
19	34143	FLANGE BOLT M8X1.25X85 MM	1
20	34144	FLANGE BOLT M8X1.25X75 MM	1
21	34588	SOCKET HEAD BOLT M6X1.0X30 MM	1
22	35182	FLANGE BOLT M10X1.5X45 MM	2
23	35207	DOWEL PIN 8X40 MM	2
24	36223	SHIFT BRACKET LABELED	1
25	37433	LOCK NUT M6X1.0	2
26	37467	SOCKET HEAD BOLT M6X1.0X16 MM	1
27	800100	BOLT M8X1.25X45 MM	1

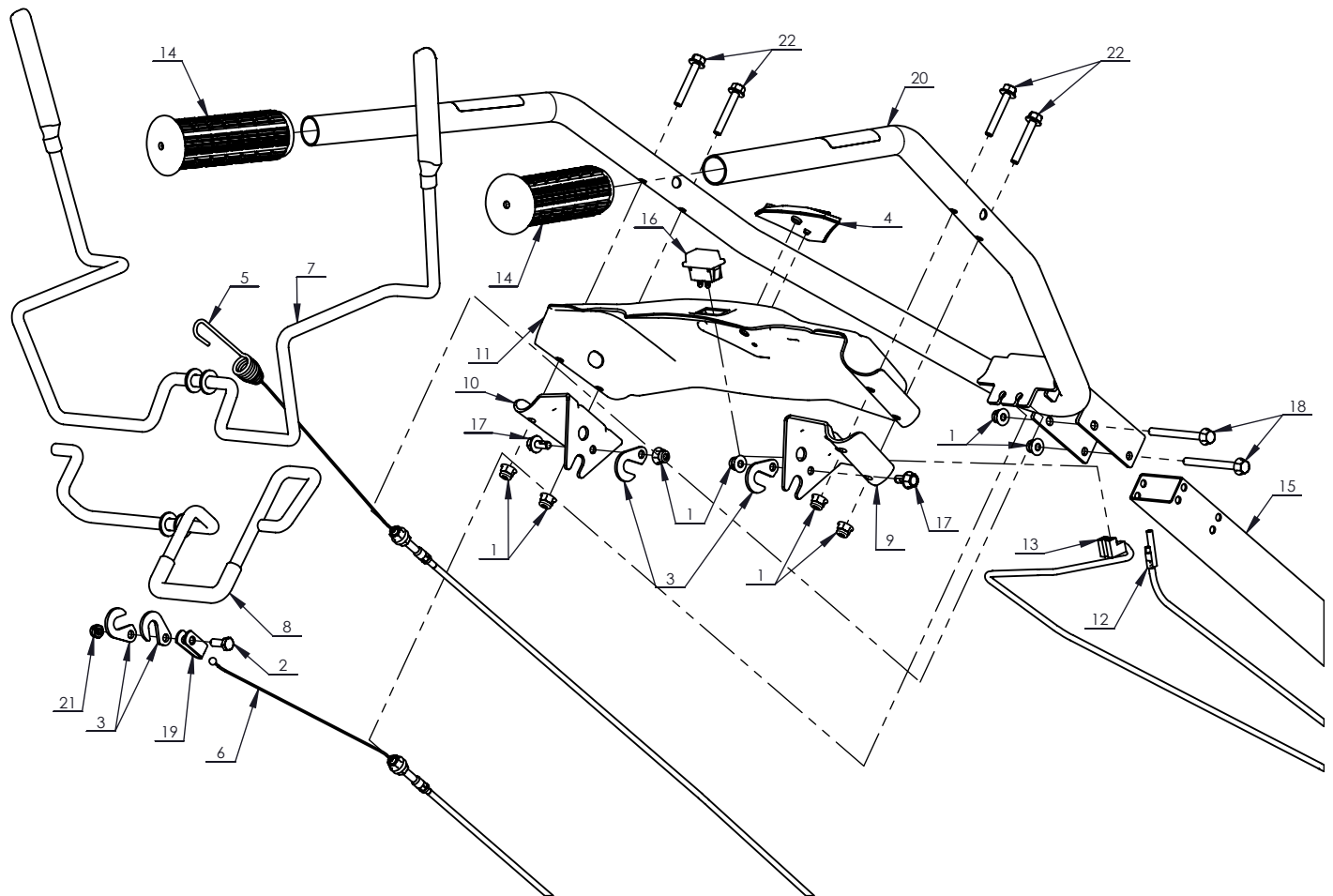

REF./REP.	PART NO. /° RÉF.	DESCRIPTION	QTY./QTÉ
1	14109	FLANGE LOCK NUT M6X1.0	8
2	17986	BOLT M6X1.0X16 MM	1
3	30924	HOOK WASHER BLACK	4
4	30995	BADGE	1
5	31244	FORWARD CABLE	1
6	31245	REVERSE CABLE	1
7	31663	FORWARD BAIL	1
8	31666	REVERSE BAIL	1
9	31667	BRACKET RIGHT BLACK	1
10	31668	BRACKET LEFT BLACK	1
11	31672	DASH RED	1

REF./REP.	PART NO. /° RÉF.	DESCRIPTION	QTY./QTÉ
12	31780	WIRING HARNESS ENGINE TO HANDLEBAR	1
13	31784	WIRING HARNESS HANDLEBAR TO SWITCH	1
14	32430	GRIP BLACK	2
15	32997	TUBE BLACK LABELED	1
16	33427	ROCKER SWITCH WITH COVER	1
17	34141	FLANGE BOLT M6X1.0X14 MM	2
18	34145	FLANGE BOLT M6X1.0X65 MM	2
19	35556	YOKE	1
20	36222	HANDLEBAR BLACK LABELED	1
21	37433	LOCK NUT M6X1.0	1
22	400021	FLANGE BOLT M6X1.0X40 MM	4

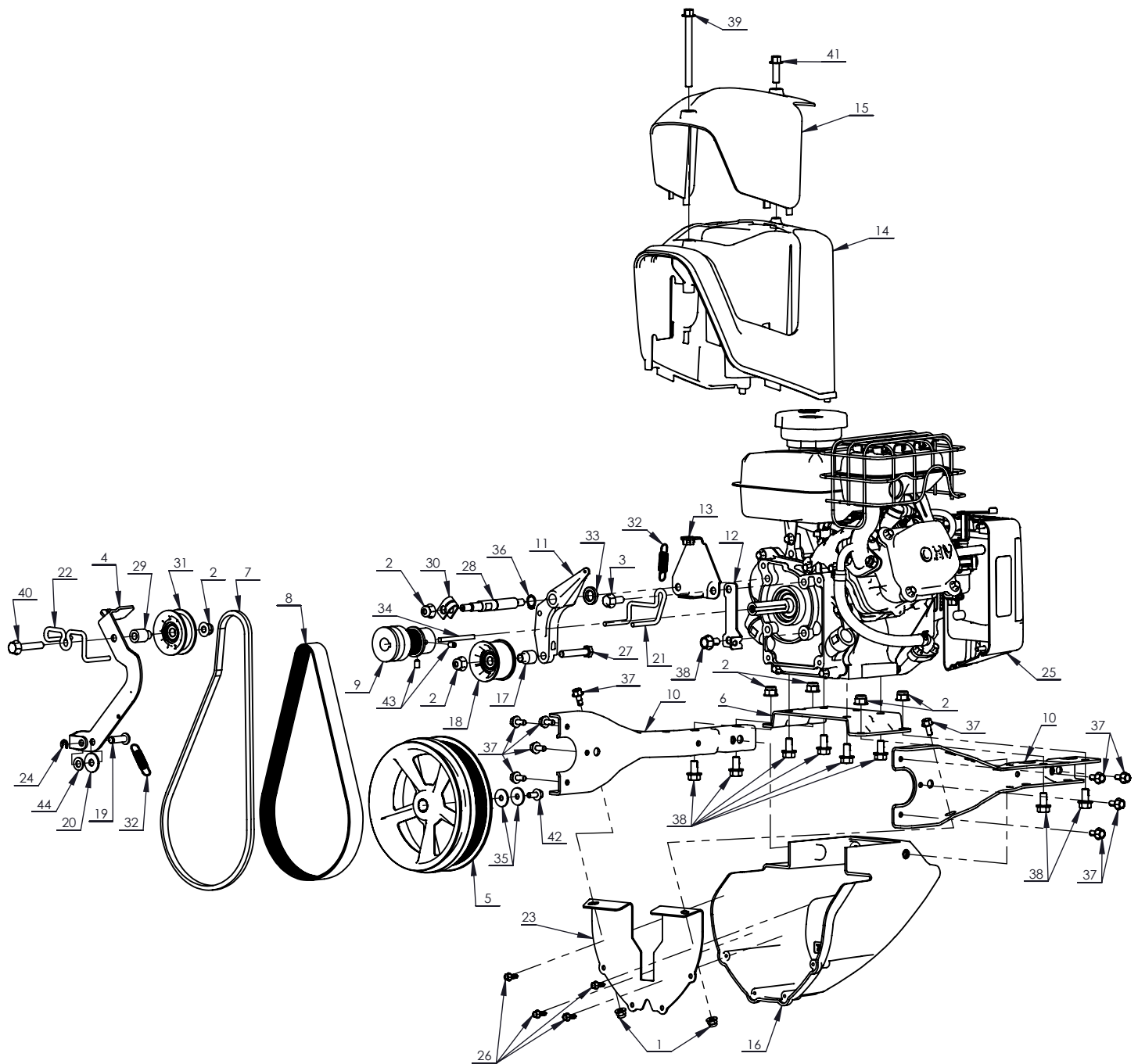

REF./ REP.	PART NO. /° RÉF.	DESCRIPTION	QTY. /QTÉ
1	14109	FLANGE LOCK NUT M6X1.0	2
2	16400	FLANGE LOCK NUT M8X1.25	7
3	19945	FLANGE BOLT M8X1.25X20 MM	1
4	31121	REVERSE ARM	1
5	31131	TRANSMISSION PULLEY	1
6	31142	ENGINE PLATE	1
7	31157	BELT V 3L864	1
8	31158	BELT POLY-V 295J10	1
9	31160	ENGINE PULLEY	1
10	31163	ENGINE MOUNT ARM	2
11	31175	FORWARD ARM	1
12	31176	FORWARD CABLE BRACKET	1
13	31415	SHROUD BRACKET	1
14	31695	UPPER SHROUD BLACK	1
15	31696	UPPER SHROUD RED	1
16	31711	LOWER SHROUD BLACK	1
17	31753	BUSHING FORWARD PULLEY	1
18	31755	FORWARD PULLEY	1
19	32201	CLEVIS PIN	1
20	3245	WASHER M8X24 MM	1
21	32633	BELT GUIDE FORWARD	1
22	32658	BELT GUIDE REVERSE	1
23	32662	PLATE LOWER SHROUD BLACK	1
24	32952	E-CLIP 6MM	1
25	33000	ENGINE 99CC 4 CYCLE	1
26	33008	FLANGE SCREW ST4.8X16 MM	4
27	3316	BOLT M8X1.25X45 MM	1
28	33333	FORWARD ARM STUD	1
29	33334	BUSHING REVERSE PULLEY	1
30	33363	YOKE	1
31	33422	REVERSE PULLEY	1
32	33424	SPRING	2
33	33602	SPACER FORWARD ARM	1
34	33607	KEY 3/16 IN	1
35	33608	WASHER M6X22 MM	2
36	33609	SNAP RING 13MM	1
37	34141	FLANGE BOLT M6X1.0X14 MM	10
38	34142	FLANGE BOLT M8X1.25X16 MM	9
39	34146	FLANGE BOLT M8X1.25X90 MM	1
40	35226	FLANGE BOLT M8X1.25X45 MM	1
41	35893	FLANGE BOLT M8X1.25X25 MM	1
42	36054	FLANGE BOLT M6X1.0X14 MM	1
43	36492	SET SCREW M6X1.0X10 MM	2
44	400024	WASHER M8X16 MM	1

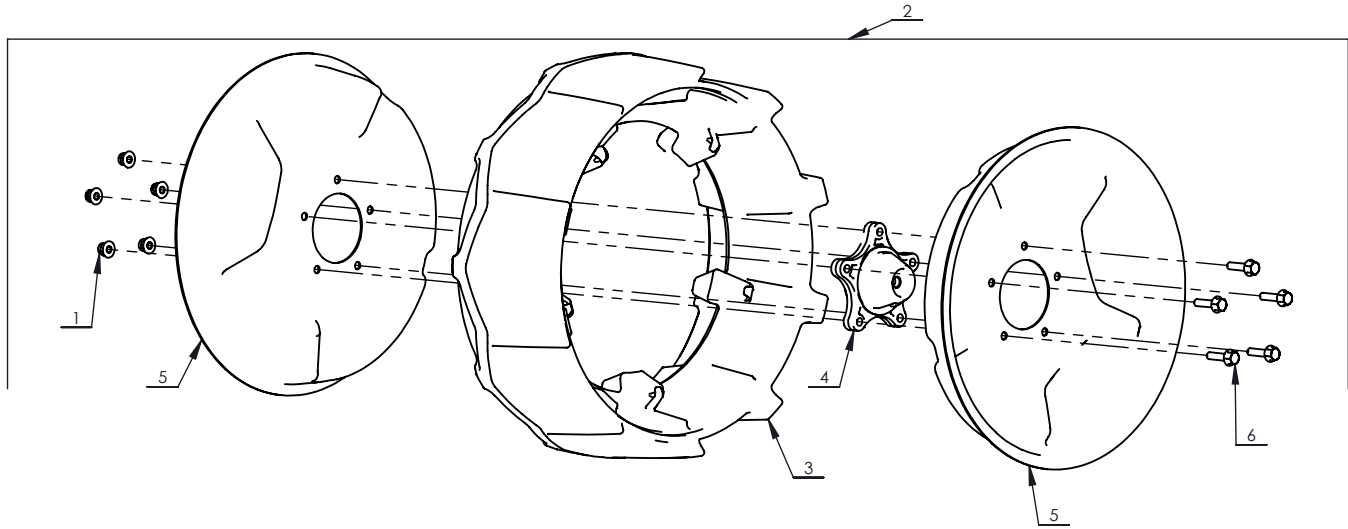

REF./REP.	PART NO. /° RÉF.	DESCRIPTION	QTY./QTÉ
1	14109	FLANGE LOCK NUT M6X1.0	5
2	27237	WHEEL ASSEMBLY	2
3	27540	TIRE	1
4	27541	HUB	1
5	27542	RIM	2
6	35196	FLANGE BOLT M6X1.0X25 MM	5

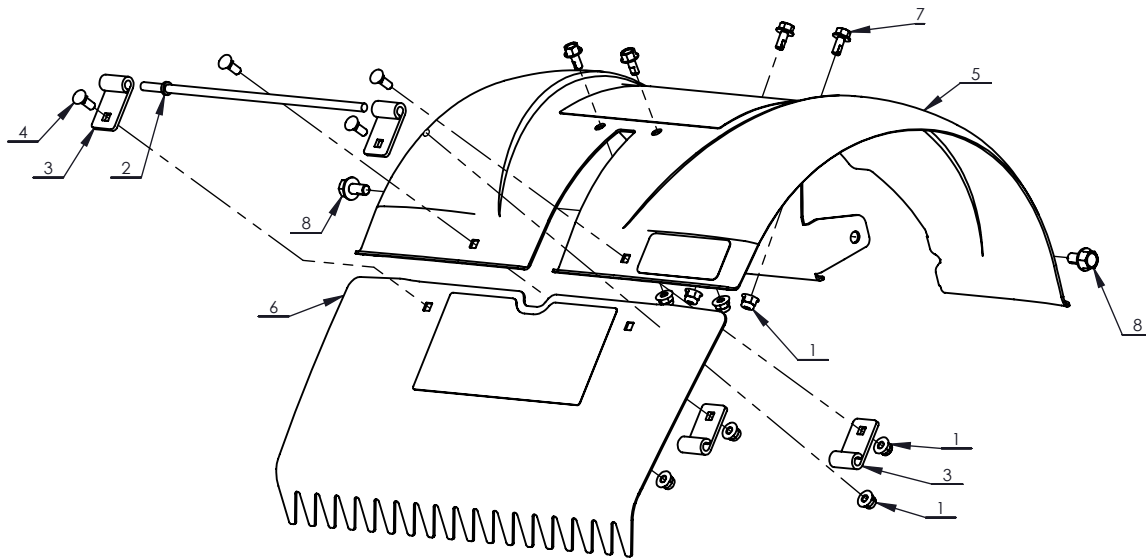

REF./REP.	PART NO. /° RÉF.	DESCRIPTION	QTY./QTÉ
1	14109	FLANGE LOCK NUT M6X1.0	8
2	24869	HINGE ROD	1
3	32427	HINGE BRACKET	4
4	32429	CARRIAGE BOLT M6X1.0X16 MM	4

REF./REP.	PART NO. /° RÉF.	DESCRIPTION	QTY./QTÉ
5	32998	TIRE SHIELD RED LABELED	1
6	32999	SHIELD FLAP RED LABELED	1
7	34141	FLANGE BOLT M6X1.0X14 MM	4
8	34142	FLANGE BOLT M8X1.25X16 MM	2

When starting engine, place free hand here.
Pour démarrer le moteur, placer le main libre ici.

17918

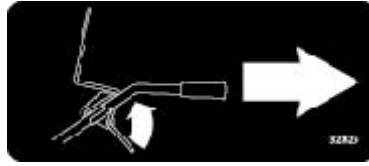

32825



32824



32828



32827



35198

⚠ DANGER
AVERTISSEMENT

⚠ Avoid Injury From Rotating Discs.
 Discs are extremely hot and may cause severe burns. Never touch discs or disc covers until they have cooled. Discs may be extremely hot after use. Discs may be extremely hot after use. Discs may be extremely hot after use.

⚠ Evitez les blessures graves.
 Les disques sont extrêmement chauds et peuvent causer de graves brûlures. Ne touchez jamais les disques ou les couvercles des disques tant qu'ils ne sont pas refroidis. Les disques peuvent être extrêmement chauds après utilisation.

⚠ Danger de blessures graves.
 Les disques sont extrêmement chauds et peuvent causer de graves brûlures. Ne touchez jamais les disques ou les couvercles des disques tant qu'ils ne sont pas refroidis. Les disques peuvent être extrêmement chauds après utilisation.

32829

⚠ DANGER
AVERTISSEMENT

⚠ Dangerous Hotting Parts.
 Discs are extremely hot and may cause severe burns. Never touch discs or disc covers until they have cooled. Discs may be extremely hot after use. Discs may be extremely hot after use.

⚠ Evitez les blessures graves.
 Les disques sont extrêmement chauds et peuvent causer de graves brûlures. Ne touchez jamais les disques ou les couvercles des disques tant qu'ils ne sont pas refroidis. Les disques peuvent être extrêmement chauds après utilisation.

32826

OPERATION / UTILISATION

See Manual For Detailed Operating Instructions.

Voir les instructions d'utilisation détaillées dans le manuel.

⚠ Pour démarrer: 1. Laisser le levier de commande de traction revenir en position neutre. 2. Mettre le coupeur à l'arrêt (OFF/RE) en position à l'arrêt. 3. Appuyer sur le bouton de démarrage ou faire tourner la commande de sélection de direction. 4. Appuyer le levier de commande des gaz en position haute. 5. Relâcher le levier de commande des gaz.

Earthquake®

32823



GROUNDBREAKING POWER EQUIPMENT

1160 Eighth Avenue
PO Box 666
Cumberland, WI 54829

Phone, Téléphone: (800) 345-6007
Fax, Télécopieur: (715) 822-2124
www.getearthquake.com