

Solar Pedestrian Light

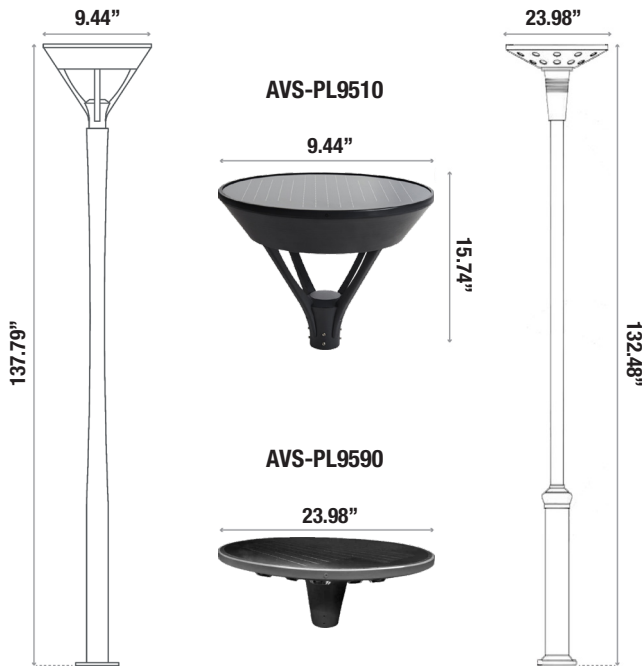

Our commercial grade solar powered pedestrian light is engineered to perform like conventional post-tops. Our lights feature high-performing LEDs, fueled by solar energy & lithium LIFEPO4 batteries, and have a compact sturdy design. Our Pedestrian lights are constructed to resist harsh environments and a lifetime of over 8 years without maintenance. All parts are built in one, they're easy to install, & available with or without poles. These are great solutions for residential and commercial applications like pathways, side walks, parks and as garden lights. There's no need for a power source, which eliminates the need for trenching or wiring. What separates a solar post light from a normal post top light is its clean power source.

- LED Solar pedestrian light fixture features an all in one design. The solar panel and battery are built into the LED fixture.
- Automatic Operation day and night detection and automatic power on and off.
- Elegant & Modern design, aluminum casting.
- Eco-friendly and safe LifePo4 battery and discharge over 2000 times has life span of over 8 years without maintenance.
- 130 Lumens per watt and IP65 rated
- 5 Years warranty on all components
- Optional – can be purchased with or without pole



Solar Pedestrian Light

Specifications

Model #	SKU #	Power	PV Type	Solar Panel	Lithium Battery	Lumens	CCT	Pole Height	IP Rating	Material
AVS-PL9510	786703	20W	MONO	45W	20AH	2600LM	5000K	12 FT	IP68	ALUMINUM
AVS-PL9590	786704	20W	MONO	45W	20AH	2600LM	5000K	12 FT	IP68	ALUMINUM

SAVINGS

INSTALLATION, ENERGY, UTILITY, AND MAINTENANCE.

Features

- Wireless Controller: LCD remote configuration for smart dimming schedules, running status, and power control.
- Automatic Operation: Day and night detection, and automatic power on and off.
- Wind Resistant: for more than 200km/hr, and wind turbine tested.
- Environment Green Energy: 0 carbone dioxide emissions.
- Battery: Lithium LIFEPO4 slow discharge for 4-5 days back up
- LED Lighting: 20W high brightness LED asymmetric lighting module.
- Power and Timing: 100% for 4hrs, 80% for 5 hrs, and 50% for 5hrs.
- Seaside Resistant: Die casting aluminum, and corrosion resistant.
- IP Rating: Water proof IP65 compliant.

Advantages

- Durable die cast aluminum construction
- Lithium LIFEPO4 Battery for fast charging
- Smart controls configuration for convience
- Powerful lithium battery, lower self-discharge rate, and longer lifespan
- Environmentally friendly and safe for enfronment

Applications

- Walking Paths
- Residence / Courtyard
- Main Roadways and Avenues
- Perimeter & Pathway Lighting
- Gardens, Residences, or Courtyards
- City Squares and Universities
- Parking Lots and Mining Areas
- Sidewalks and Public Spaces

Correlated Color Temperature

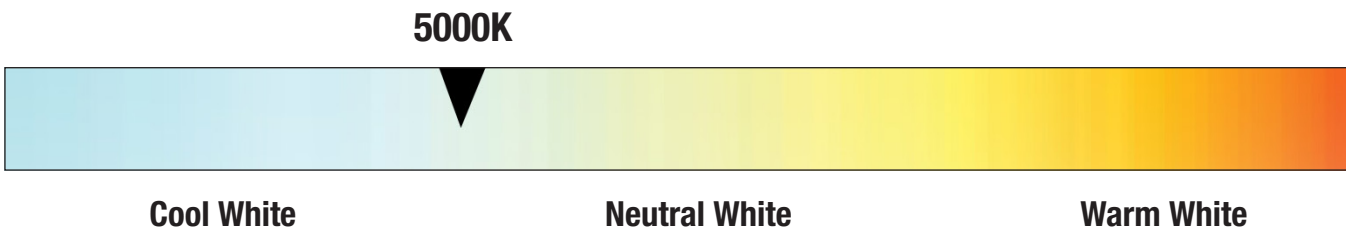

Solar Pedestrian Light

Product Design and Benefits

LUMINAIRE HOUSING

High pressure die-cast low-copper aluminum. Protection class of IP66. Beyond Solar uses a high quality Polyester Powder Coating from AKZO NOBEL. This powder coating product provides an excellent salt and humidity resistance as well as ultraviolet resistance for color retention.



LIGHTING A TOTAL OF 2600 LUMENS

16 high flux Phillips LEDs of 130 Lumens per Watts. LEDs are mounted to PC boards and directly attached to upper housing for best thermal management.

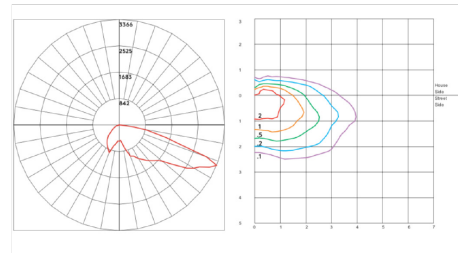

SOLAR PANNELS 45 watts 18V

Encapsulated Monocrystalline Solar Panel Grade Solar Cell with Tempered Glass.



OPERATION MODE

THE PHOTOSENSOR WILL AUTOMATICALLY TURN THE LIGHT ON & OFF FROM DUSK TO DAWN.



Solar Pedestrian Light

Product Design and Benefits

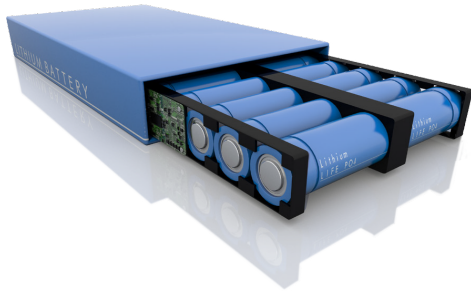

BATTERIES LIFE PO4 BATTERY

-25AH/12,8 AH LITHIUM IRON PHOSPHATE BATTERY

The Eco-friendly and safe LiFePO4 Li-ion battery improves the cyclic charge and discharge **over 2000 times** and has a life span of **more than 10 years**.

✓ **SAFE** No Explosion Risk

LITHIUM LIFEPO4

VS

LITHIUM LI ION

Over 2000 cycles	⌚ Over 500 cycles
No Risk of Explosion	✓ Very High Risk Explosion in High Temperature
-10 to 75 Degree	🌡️ 0 to 45 Degree
Over 10 Years	📅 24 to 32 Months
.....	💰 50% Cheaper than LiFePO4

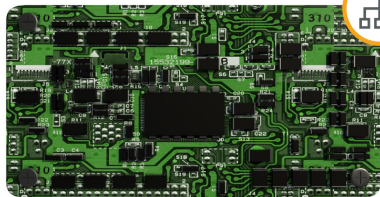

MULTI PROTECTION

SMART CONTROLLER MPPT



MPPT (Maximum Power Point Tracking) controller automatically track the maximum power point according to the weather variation.
Charging rate : 16-30%

FEATURES

- Maximum power point tracking charging
- Auto identify day/night
- 4 levels dimming design
- Smart mode operation
- **Waterproof IP68**

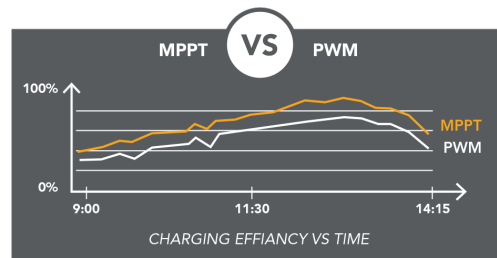

BATTERY MANAGEMENT SYSTEM BMS

The electronic Algorithm protect the battery from operating outside its safe operating area monitoring its state, calculating secondary data, reporting that data, controlling its environment, authenticating it and / or balancing it.

- | | | |
|-----------------|----------------|--------------------|
| ⚡ OVER LOAD | ⚡ OVER CURRENT | ⊗ OVER TEMPERATURE |
| ⬆️ OVER VOLTAGE | ⬇️ OVER CHARGE | ⬆️ OVER DISCHARGE |

Solar Pedestrian Light

Dimensions

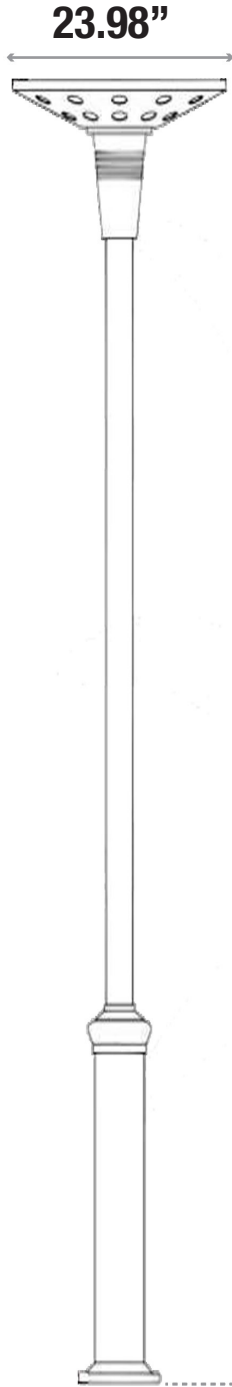

AVS-PL9590



Solar Pedestrian Light

Dimensions

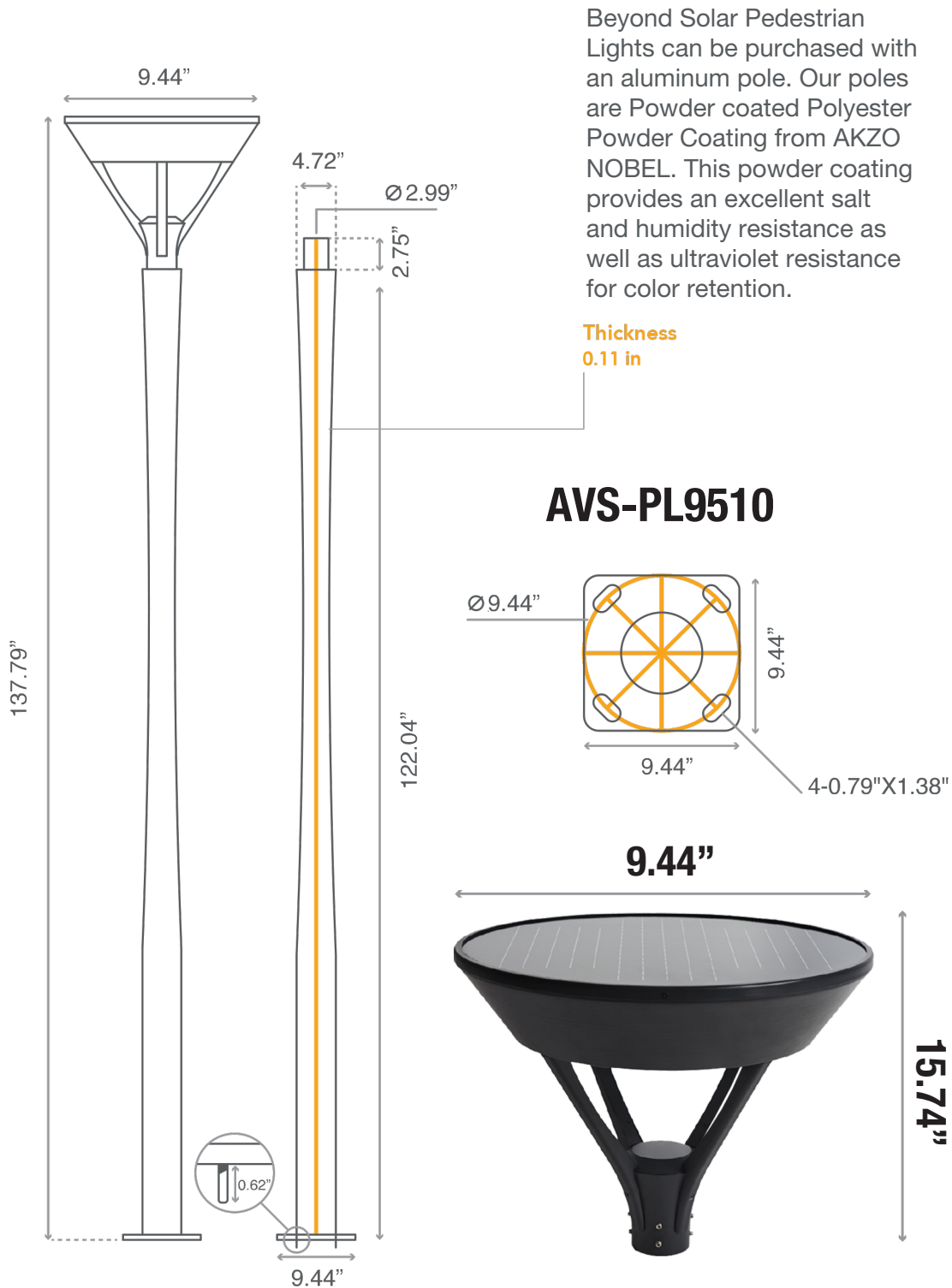

Solar Pedestrian Light

Recommended Pole Distance for Installation

The pole distance and lamp installation height vary depending upon your chosen fixture.

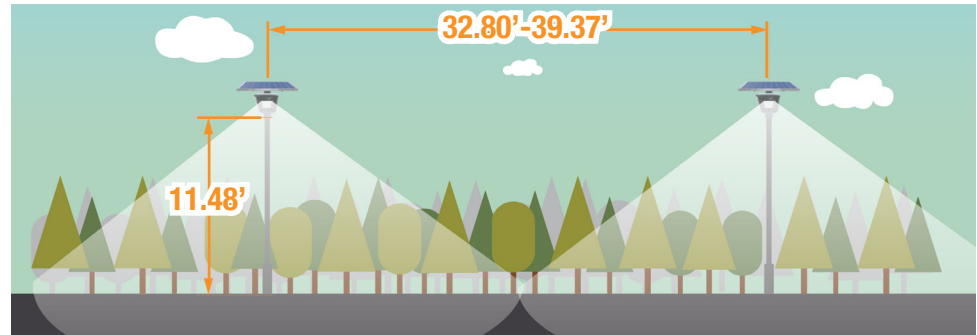

Wireless Controller

With LCD remote configure smart dimming schedules, running status, and power control.



LED Lighting

20W high brightness, LED asymmetric lighting module, Philips Luxeon



Automatic Operation

Day and night detection with automatic power ON and OFF.



Wind Resistant

More than 200 KM/H wind resistant, wind turbine tested

CONTROLLER AND OTHER SPECIFICATIONS

Wireless Controller	LCD remote configuration smart dimming schedules, running status, and power control
Battery	Lithium LIFEPO4 slow discharge for 4-5 Days back up
Automatic Operation	Day and night detection for automatic power on and off
LED Lighting	20W high brightness LED asymmetric lighting module, Philips LUXEON
Wind Resistant	More than 124.27 m/h wind resistant, wind turbine tested
Seaside Resistant	Die casting aluminum Azonobel painted corrosion resistant
Environment	Green Energy: 0 Carbone Dioxide Emissions
IP Rating	IP65 Compliant



Solar Pedestrian Light

Premium Solar Lighting

Monocrystalline solar panels are generally thought of as a premium solar product. The main advantages of monocrystalline panels are higher efficiencies and sleeker aesthetics.

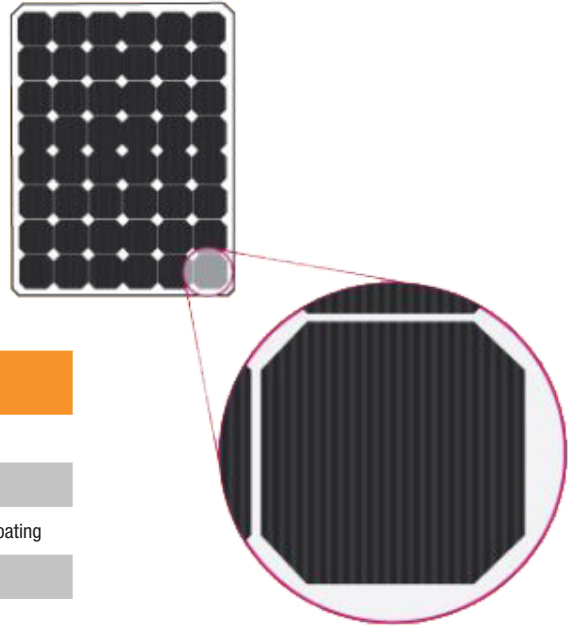

MECHANICAL SPECIFICATIONS

Space Between Light	32.80'-39.37'
Mounting Height	11.48' Under the Light (Customizable)
Pole Material	Hot Galvanized Steel > 100 Microns Zinc Coating
Warranty Period	3 Years to Depend with Configuration

Durable and Environmentally Friendly

Constructed using high quality seaside resistant die casting aluminum and hot galvanized steel. Corrosion resistant for long lasting quality lighting that withstands wear and tear from harsh environment conditions. Also, 100% safe for the environment and produces 0 carbon dioxide emissions to help make the environment safer for others.



Seaside Resistant

Die casting aluminum, Akzonobel painting, corrosion resistant



Waterproof

IP65 Compliant



Environment

Green energy: 0 Carbon dioxide emissions



Battery

Battery Lithium LIFE04 slow discharge for 4-5 days back up



Solar Pedestrian Light

SOLAR PATHWAY LIGHTS



Solar Pedestrian Light



SOLAR PATHWAY LIGHTS



Solar Pedestrian Light

SOLAR PATHWAY LIGHTS



Solar Pedestrian Light



SOLAR PATHWAY LIGHTS

