

# CASTOR™

## Solar Area Street Light



Our Castor Solar Area Light is economical, easy to install, completely off grid, unique new design with all the solar lighting advantages is great solution for area such as pathway, parking lot, roadway, trails or any remote area that have no access to conventional Power. Our Castor Solar Area Light features an integrated solar panel, battery and Light fixture with easy to install mounting eliminates trenching to bury electrical wires and the savings continues since there is no monthly electrical bill. Available from 1100 lumen to 16800 lumen package.

- Economical, Easily to install, all in one integrated with fixture on one side and panel on the other side.
- Philips High Efficiency LEDs with heat dissipation design, pure aluminum lamp base with seal lens for an optimal lighting and life span.
- The light automatically switches on at dusk and switches off at dawn. 30% permanent lighting, when motion is detected power turns to 100%.
- Eco-Friendly and safe LifePO4 battery and discharge over 2000 times has life span of more then 10 years
- 140 Lumen per watt and IP65 Rated
- Batwing Lens for a perfect illumination and uniformity
- MPPT controller automatically track the maximum power point according to the weather variation, charging rate 16 to 30%
- 5 Years limited warranty on all components



# CASTOR™

## Solar Area Street Light

### Specifications

Model #	SKU #	Power	PV Type	Solar Panel	Lithium Battery	Lumens	CCT	Charge Time (Hrs)	Weight (Lb)	Installation Height (Ft)
AVS-AI1-20W	786161	20W	MONO	50W	17AH	2100lm	5000K	6 - 8 H	30.8	18
AVS-AI1-40W	786181	40W	MONO	66W	26AH	4300lm	5000K	6 - 8 H	46.2	23
AVS-AI1-50W	786191	50W	MONO	70W	36AH	5500lm	5000K	6 - 8 H	46.2	24
AVS-AI1-80W	786211	80W	MONO	100W	60AH	8200lm	5000K	6 - 8 H	52.8	30
AVS-AI1-100W	786222	100W	MONO	130W	80AH	11000lm	5000K	6 - 8 H	57.2	33
AVS-AI1-120W	786231	120W	MONO	150W	88AH	15000lm	5000K	6 - 8 H	61.6	36

### Advantages

With infrared body induction controlled technology, it can store energy during the daylight, and modulate the lamp's brightness when people pass through at night. During the night, the sensor will work automatically controlled by intelligent induction module. It will be on 100% full bright mode when people pass through and on energy-saving mode when people leave away.

### Applications

- Areas with no electrical supply
- Main Roadways and Avenues
- Perimeter Lighting
- Gardens, Residences, or Courtyards
- Parking Lots and Mining Areas
- Sidewalks and Public Spaces

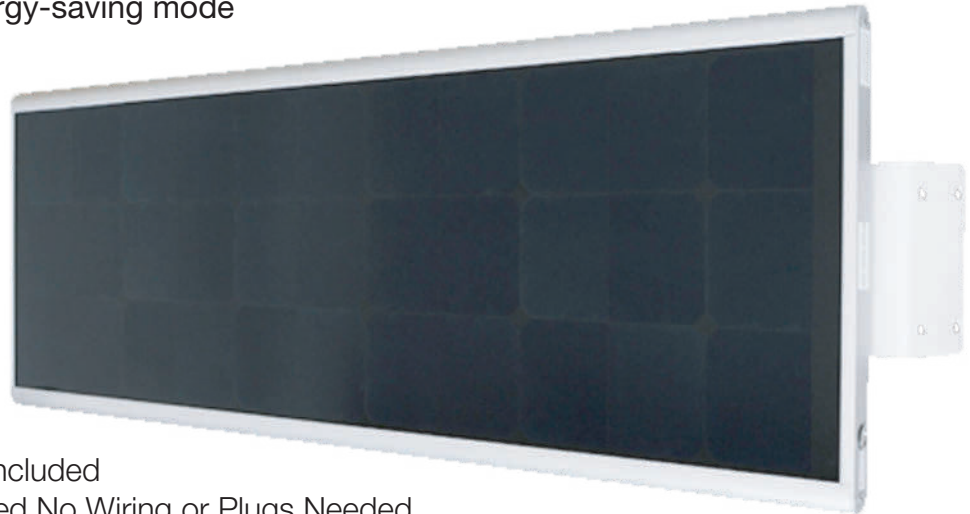

### Features

- IP65 Rated
- PIR Motion Sensor
- All Mounting Hardware Included
- Completely Solar Powered No Wiring or Plugs Needed
- 2 Hrs at 100%, 3 Hrs at 80%, 4 Hrs at 50%, 3 Hrs at 30%



# CASTOR™

## Solar Area Street Light

### Product Design and Benefits

The integrated design makes the light simple, stylish and practical; solar energy supply means clean energy and clean energy means saving costs. Once installed, it will not be no need for any additional other costs.

The luminaire can be adjusted to different angles, depending on the latitude and characteristics of the land. It can be installed vertically and horizontally, or on a wall. It is designed to be installed, maintained or repaired easily. Its surface can absorb all the solar energy, and its infrared body sensor modulates to save energy during night-time. All this without cables!

The Lithium battery is compressed and has three main characteristics: reduced size, high-capacity and long life-span. Up to 120 Lm/W (Lumens per Watt) light output and +95% driver efficiency.

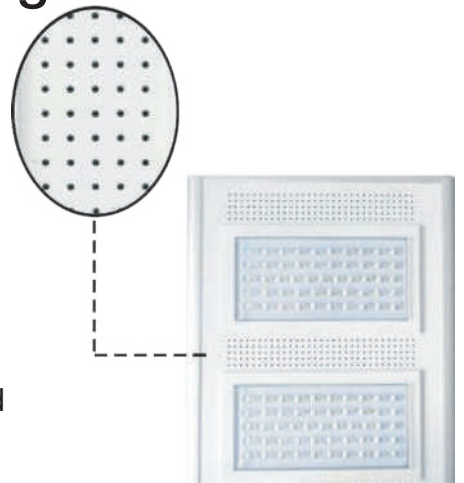

Solar Panel



Lithium Battery



Controller

### Electric Specifications

Model #	SKU #	Power	LED No.	Light Type	Solar Panel	Lithium Battery	Constant Worktime at Full Power	Charge Time (Hrs)	Pole Distance (Ft)	Installation Height (Ft)
AVS-AI1-20W	786161	20W	21 Pcs	1S	50W	17AH	>12Hrs	6 - 8 H	65.6-68.9	18
AVS-AI1-40W	786181	40W	42 Pcs	1S	66W	26AH	>14Hrs	6 - 8 H	82-88.6	23
AVS-AI1-50W	786191	50W	54 Pcs	1S	70W	36AH	>14Hrs	6 - 8 H	88.6-98.4	24
AVS-AI1-80W	786211	80W	84 Pcs	1S	100W	60AH	>12Hrs	6 - 8 H	118.1-124.7	30
AVS-AI1-100W	786221	100W	102 Pcs	1S	130W	80AH	>10Hrs	6 - 8 H	128-131.2	33
AVS-AI1-120W	786231	120W	120 Pcs	1S	150W	88AH	>10Hrs	6 - 8 H	134.5-137.8	36



# CASTOR™

## Solar Area Street Light

### American Bridgelux 45Mi1 LED Source

With infrared body induction controlled technology, it can store energy during the daylight, and modulate the lamp's brightness when people pass throughout the night. During the night, the sensor will work automatically controlled by intelligent induction module. It will be on 100% full bright mode when people pass through, and on energy-saving mode when people leave. (Lighting mode can be adjusted according to client's demands).



### Infrared Body Sensor

These solar street LIGHT have an American Bridgelux LED source, provide excellent luminous efficiency up to 120LM/W, and keep permanent stability as well as comfortable visual experience. Each Bridgelux LED has anti-static protection element, so as to avoid harm from static electricity.

### Correlated Color Temperature

5000K

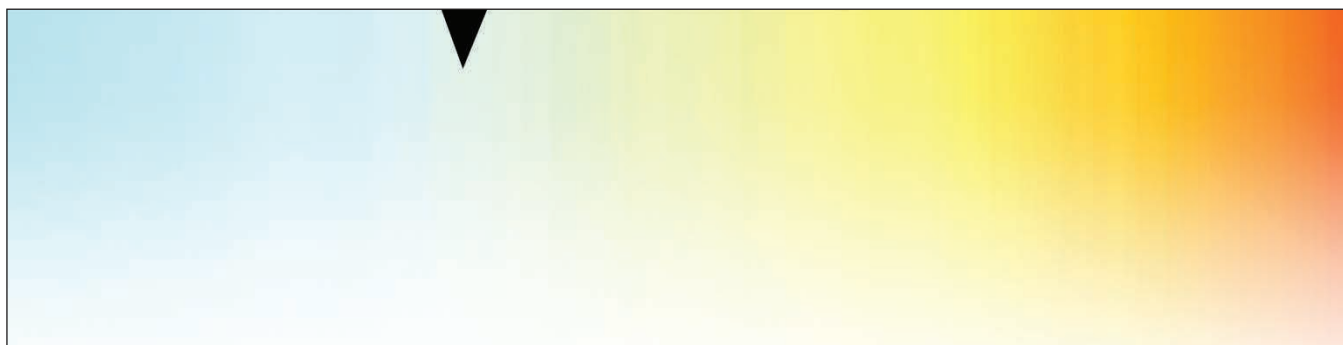

Cool White

Neutral White

Warm White





# CASTOR™

## Solar Area Street Light

### Light Distribution

SOLAR AREA LIGHT

#### AVS-A11-20W

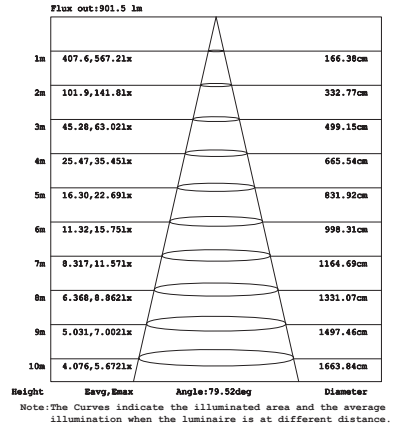
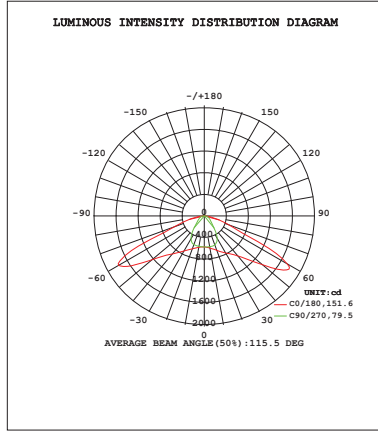
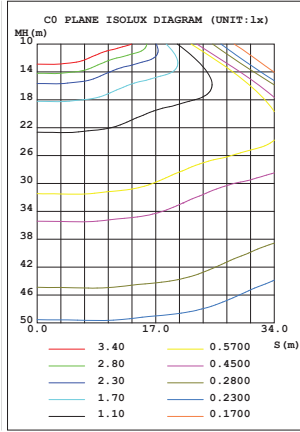

#### AVS-A11-40W

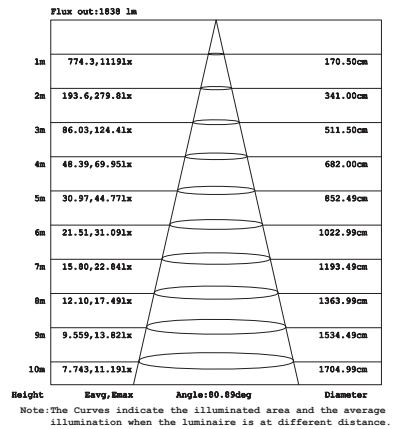
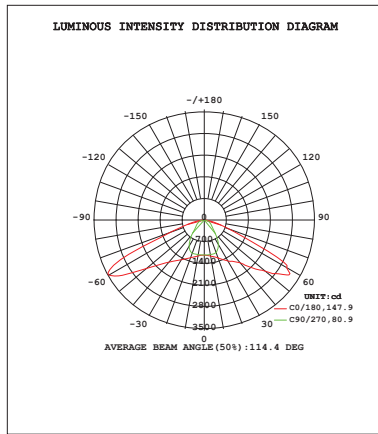
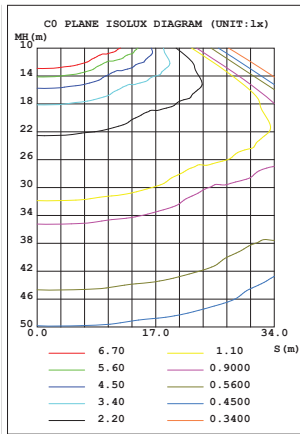

#### AVS-A11-50W

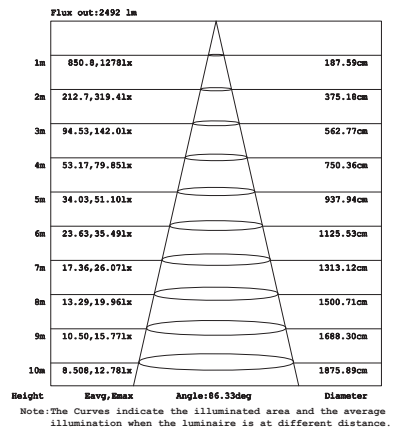
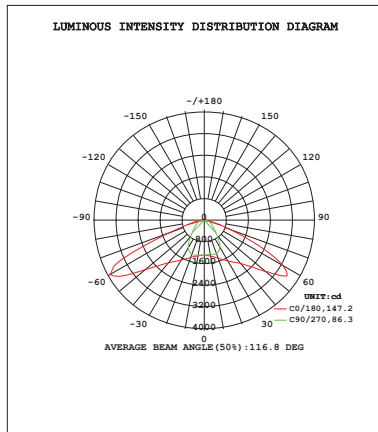
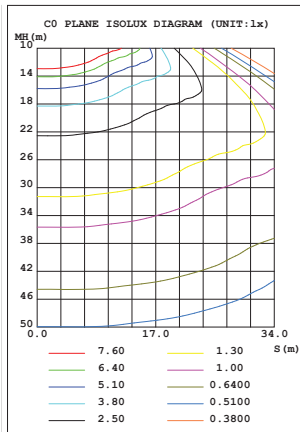

# CASTOR™

## Solar Area Street Light

### Light Distribution

AVS-AI1-80W

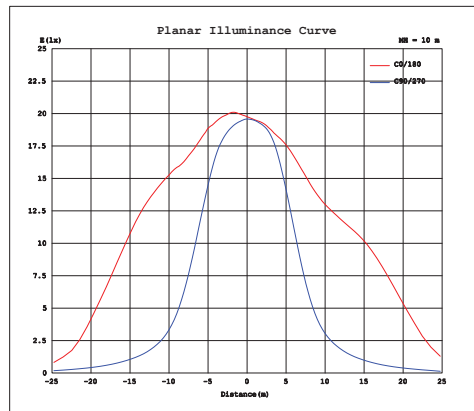
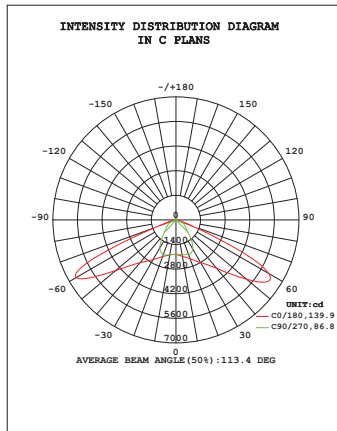
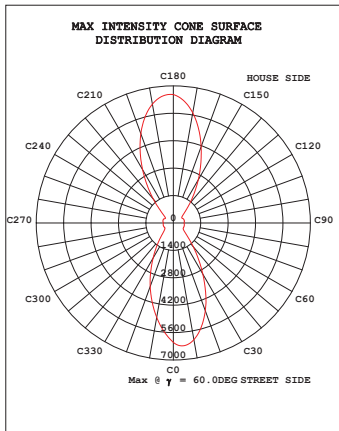

AVS-AI1-100W

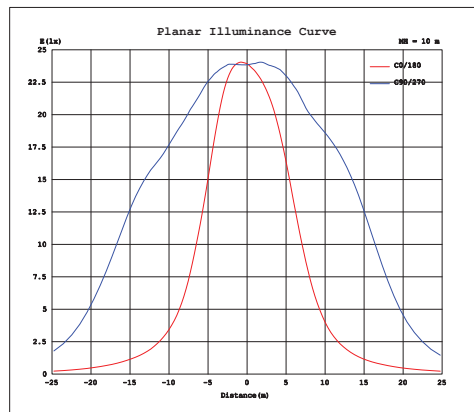
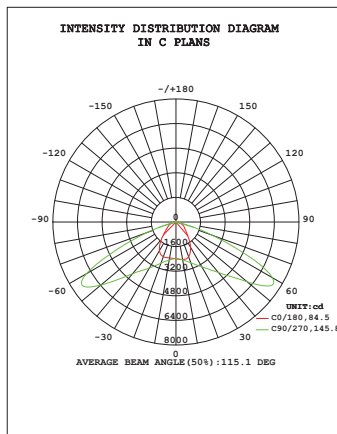
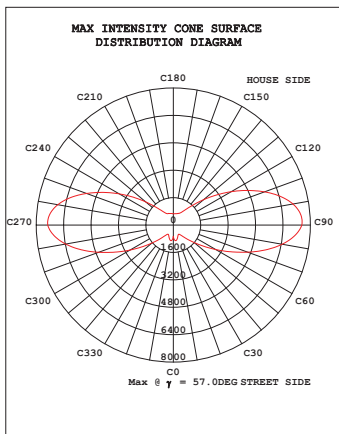

AVS-AI1-120W

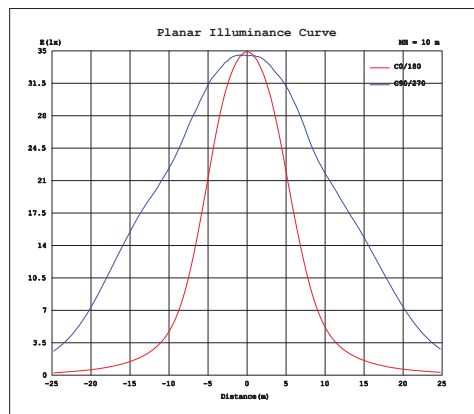
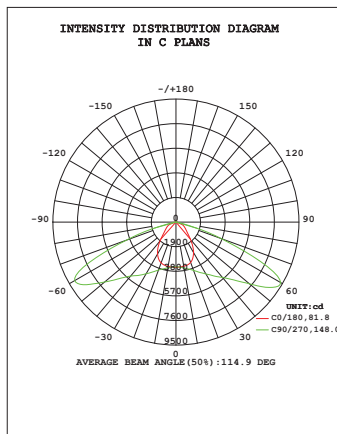
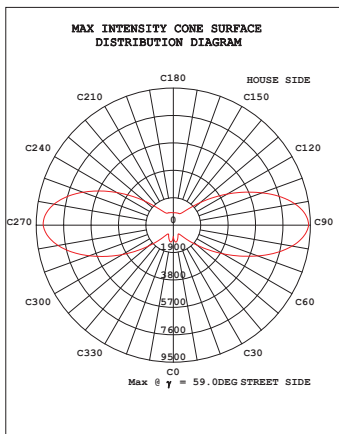

SOLAR AREA LIGHT



# CASTOR™

## Solar Area Street Light

### Optimum Panel Orientation

The Solar charge in a battery pack won't last forever. The off-grid system relies on stored solar energy for autonomy. Angling your solar panels properly can boost the power intake of your solar lighting system. You want to angle your solar panels at a tilt based on the area's latitude.

#### Tip for Maximum Power

You can increase the tilt 15° in the winter or decrease 15° in the summer. In this way you can get the maximum sunlight to recharge the battery.

### Best Facing Direction of Solar Panel

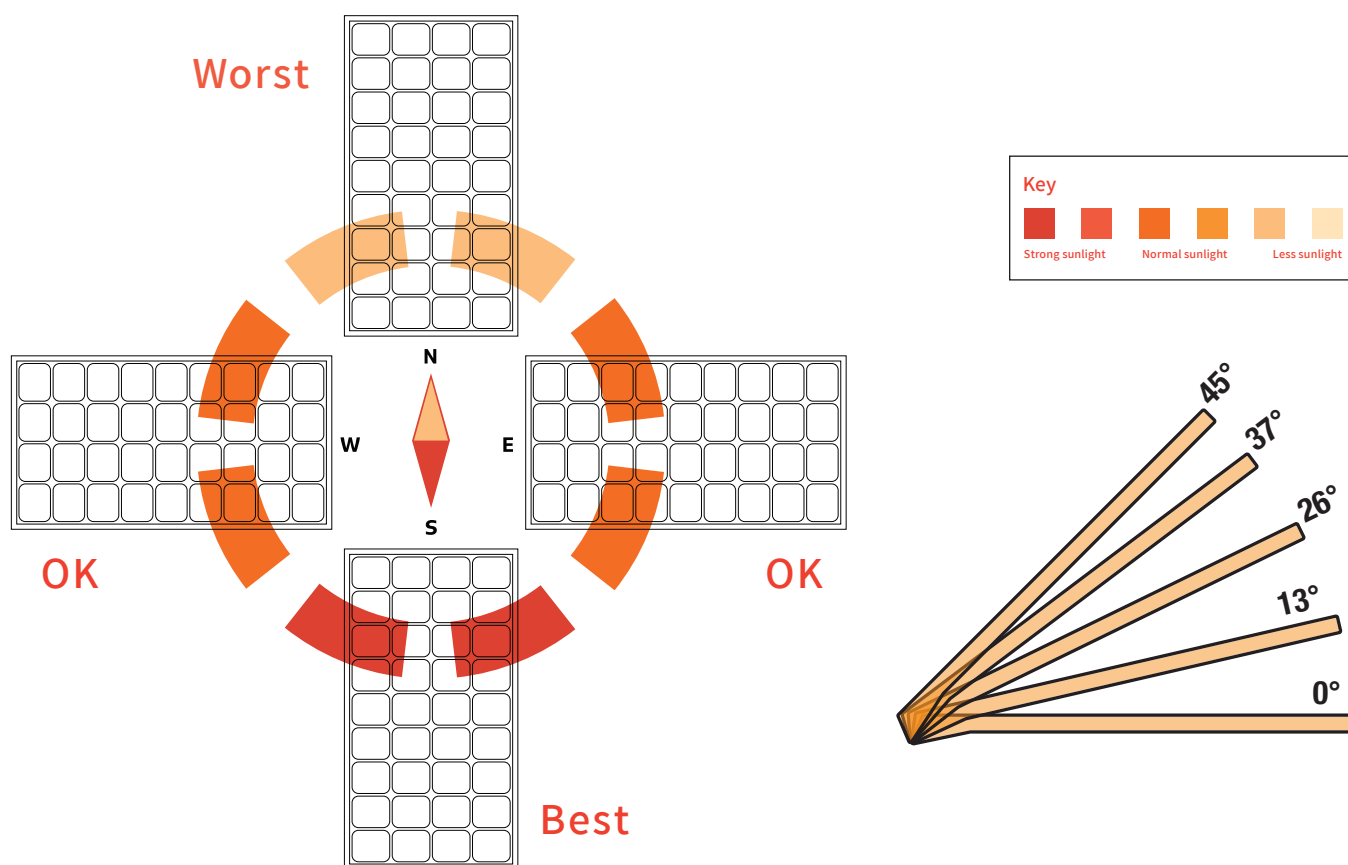

The area will dictate the installation of the fixtures and will sometimes prevent the LIGHT from facing south. Panels facing West & East won't get as much light as Southern facing panels, but will still collect a good amount of sunlight. A North facing panel also works, but it will take longer to charge than any other direction. This would mean that the solar charge will be less optimal if installations are facing North.



# CASTOR™

## Solar Area Street Light

### Optimum Panel Orientation

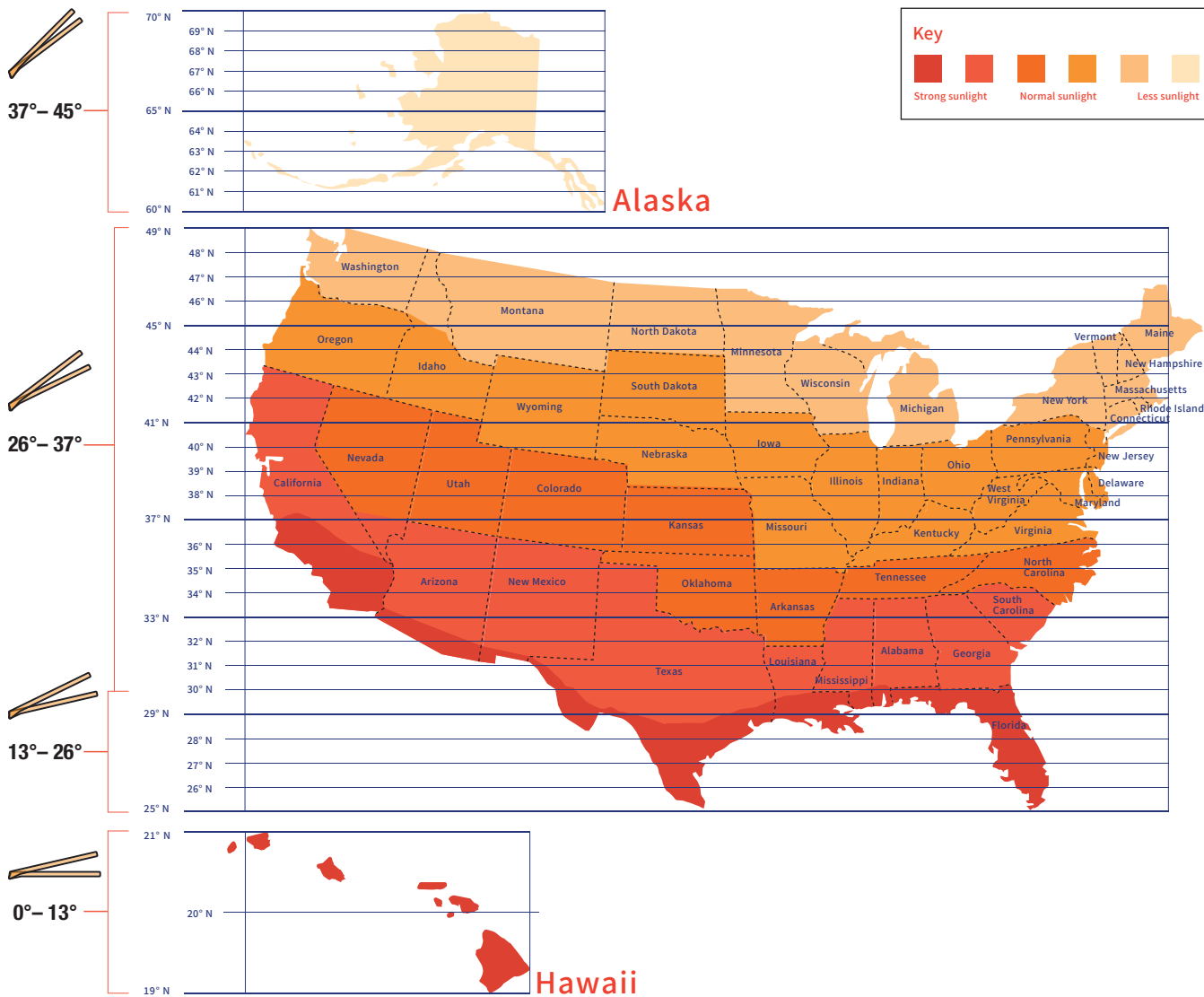

SOLAR AREA LIGHT

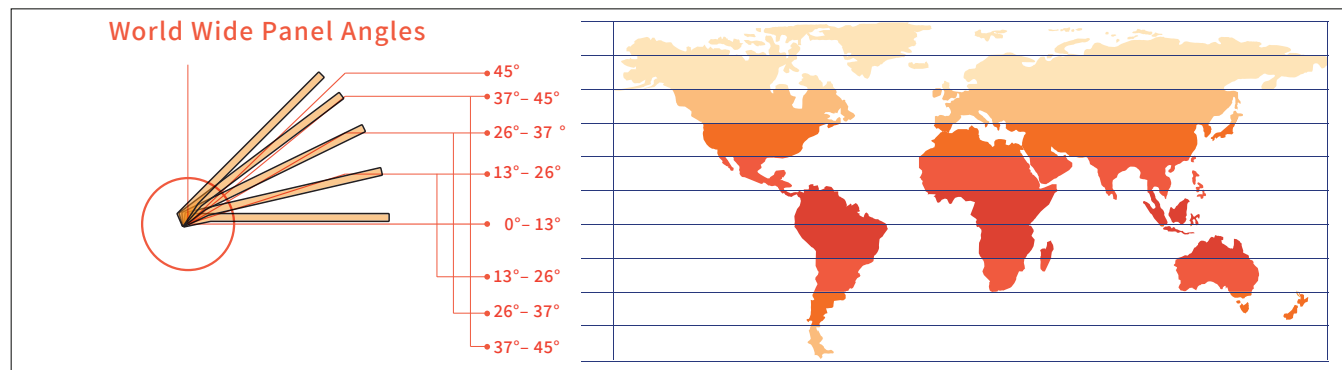



# CASTOR™

## Solar Area Street Light

### Dimensions

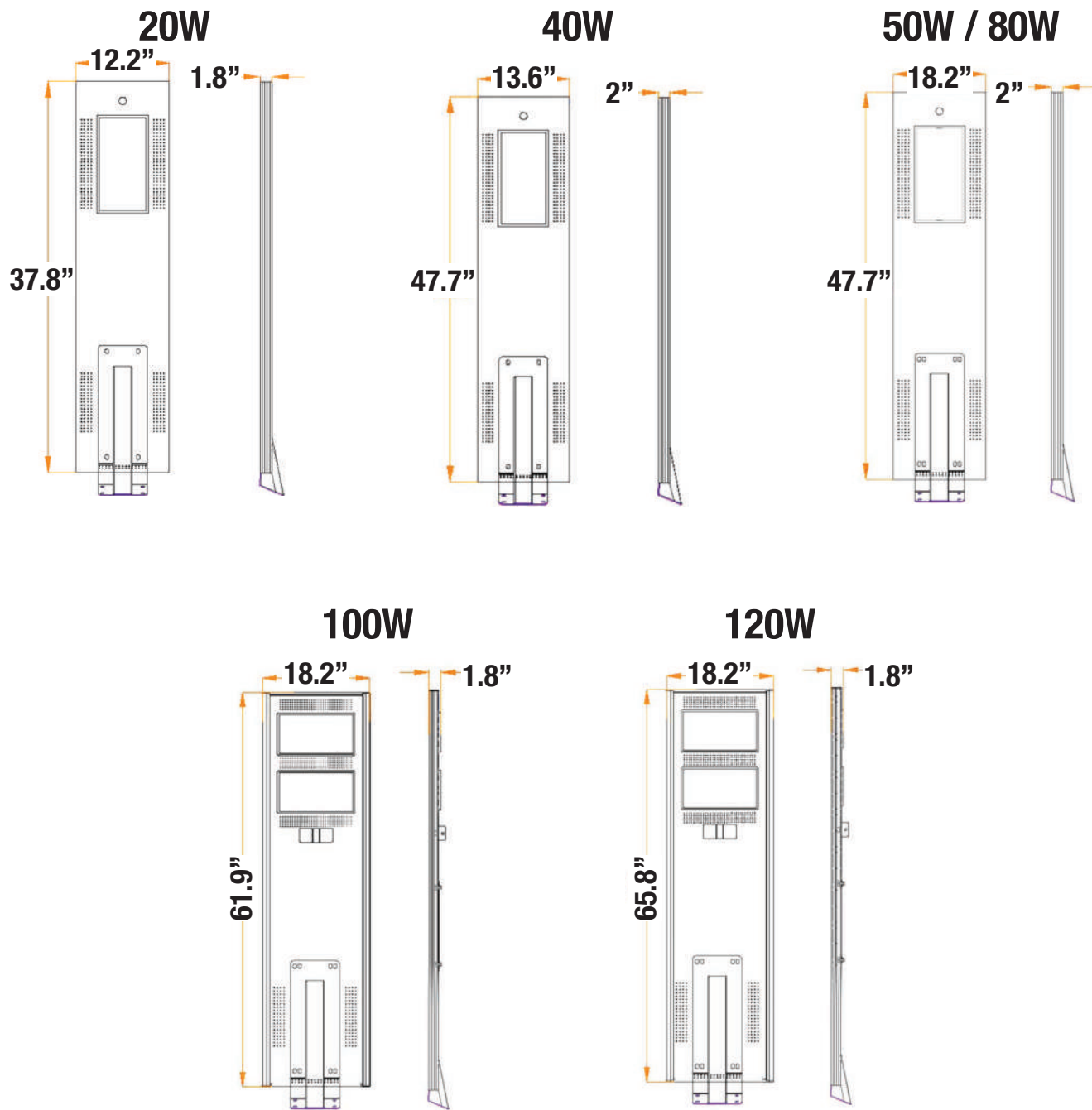

# CASTOR™

## Solar Area Street Light

### Installation

The installation can be adjusted according to different environments or illumination needs.



- APP mobile function control
  - Automatic Light Control
  - Time Control
  - Infrared Human Sensor
- (Mobile APP: through bluetooth connection, users can set 7-10 raining days, detection, maintenance, etc.)



# CASTOR™

## Solar Area Street Light

### Installation

#### Contents

Product Maintenance and Disposal .....	12
1.1 Caution.....	12
1.2 Disposal.....	13
User Manual.....	14
2.1 Introduction.....	14
2.2 Part Description.....	15
2.3 Packing List.....	16
2.4 Installation Guide.....	17



# CASTOR™

## Solar Area Street Light

### Installation

#### 1. Product Maintenance and Disposal

##### 1.1 CAUTION:

Please carefully read the following directions when you use the AOS All-in-one solar street light in order to avoid damage or malfunction.

Do not drop this product or drop any item thereon.

Do not immerse this product in the water.

Do not use any detergent that contains ammonia, benzene or abrasant to avoid any damage to the product.

For long-term storage, batteries need to be recharged every 6 month to maintain battery life.

When installing, **keep away from the shadow of trees, building and etc.,** so as to avoid the damage to the solar panel.

Please don't replace the faulty parts with parts from other suppliers to avoid damaging other components.

#### Operating and Storage Temperature

The discharge temperature ranges from -4°F to 140°F (-20°C to 60°C)

Recharge at a temperature between 32°F to 140°F (0°C to 60°C)

The controller will automatically stop charging in order to protect the battery if the temperature drops below -2°F (-10°C) or rises above 140°F(60°).

Please ensure not install the products in the area where the extreme temperature conditions exceed its limits.

Store the products at a temperature between -4°F to 113°F (-20°C to 45°C)

#### Modification:

It is not on the term of warranty if client does modify and refit the light leading to non-proper working without authorization.



# CASTOR™

## Solar Area Street Light

### Installation

#### 1.2 Disposal:

Our product is made of recyclable high-performance materials and components according with ROHS. Do not throw away the appliances with the normal household waste at the end of their life, and hand them in at official collection point for recycling. By doing this, you help to preserve the environment.

Please refer to local laws and regulations involved in classified collection of electrical products and electrons. Properly-disposing of the wastes can helpfully avoid negative influence to environment and human health.





# CASTOR™

## Solar Area Street Light

### Installation

#### 2. User Manual

##### 2.1 Introduction:

The AOS series is extremely versatile, robust all-in-one LED solar light. Their integrated photo voltaic module, Lithium battery, human infrared sensor and newly developed charging controller and LED lamp to achieve multiple features such as high luminance, long lifespan, minimal maintenance and easy installation.

To avoid incorrect operation that may lead damage the unit, please read the following instructions for AOS solar light carefully before installation.

1. AOS units do not work without sunlight. Please choose the appropriate model according to radiance or peak sun hours for the location of installation. In areas that are short for sunlight or after continuous days of rain, AOS units may only work shortly or may not turn on at all.

2. AOS units should be installed with the solar panel facing equator for best performance and durability. Make sure to clear trees, buildings and other shadows, or the internal battery will not charge properly and the efficiency of the solar panel will be minimized, influencing the working time of unit and battery life.

3. By factory setting, AOS units turn on at dusk and off at dawn automatically. During the evening, AOS units work at dim mode when humans are not detected the light power is reduced to 50% and it will increase to 100% output immediately when a motion is detected. When the air temperature is close to temperature of human body, motion detecting speed may slow down.

4. All internal parts of AOS are rated IP65 and are waterproof. Holes and slits on the luminaires are designed for heat dissipation and drainage. Metal parts are anodized rust-proof aluminium which can withstand high temperatures and humidity weather. The high strength structure design can withstand wind speed of 180km/h, over this speed may damage units.

During the evening, AOS units work at dim mode when humans are not detected the light power is reduced to 50% and it will increase to 100% output immediately when a motion is detected.

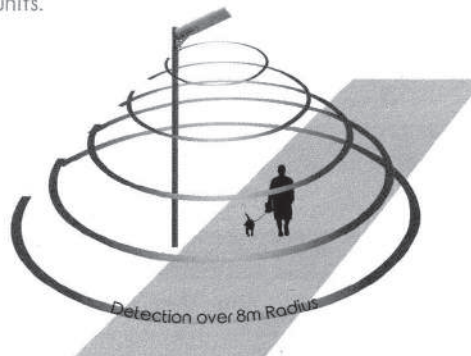

# CASTOR™

## Solar Area Street Light

### Installation

#### 2.2 Part Description

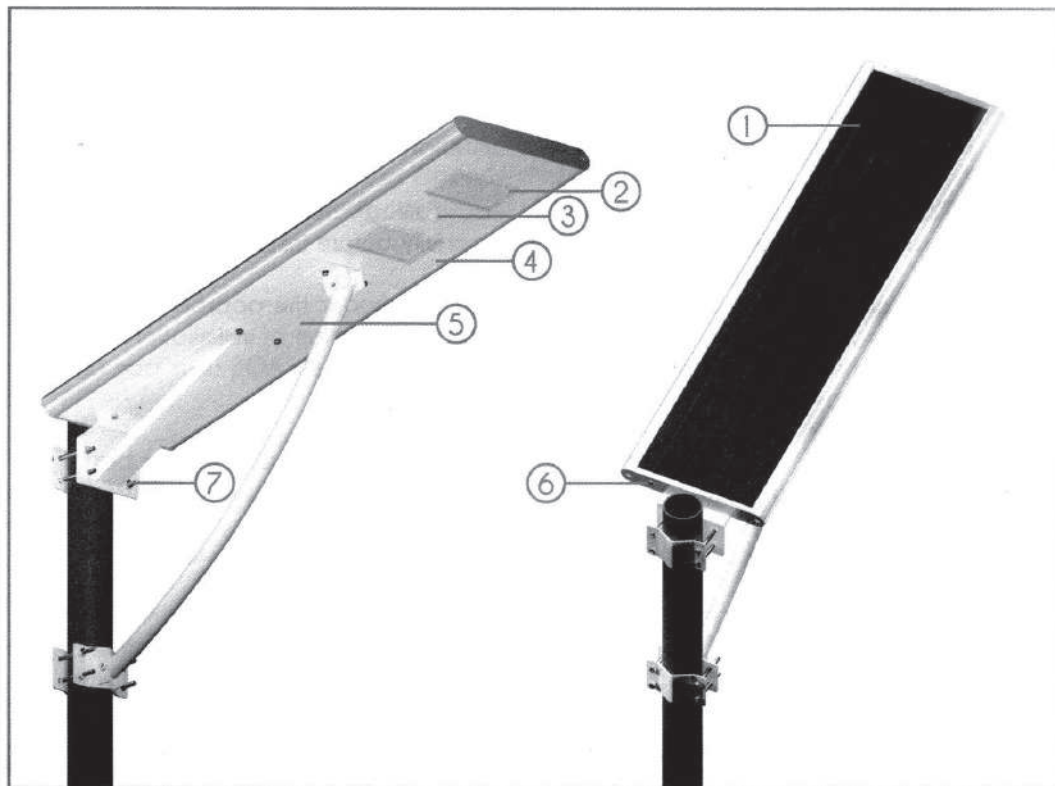

No.	Name	Brief Function
1	Solar Module	Charge Battery
2	LED Module	Illumination
3	PIR Sensor	Motion detection
4	Heat-sink Hole	Heat dissipation
5	Controller	Charging and discharging control
6	Switch On/Off	Brief Function
7	Anti- theft Bracket	Fix main body and lamp head



# CASTOR™

## Solar Area Street Light

### Installation

#### 2.3 Packing List

Please open the package and confirm that all parts were received prior to installation. The parts of each type are listed below

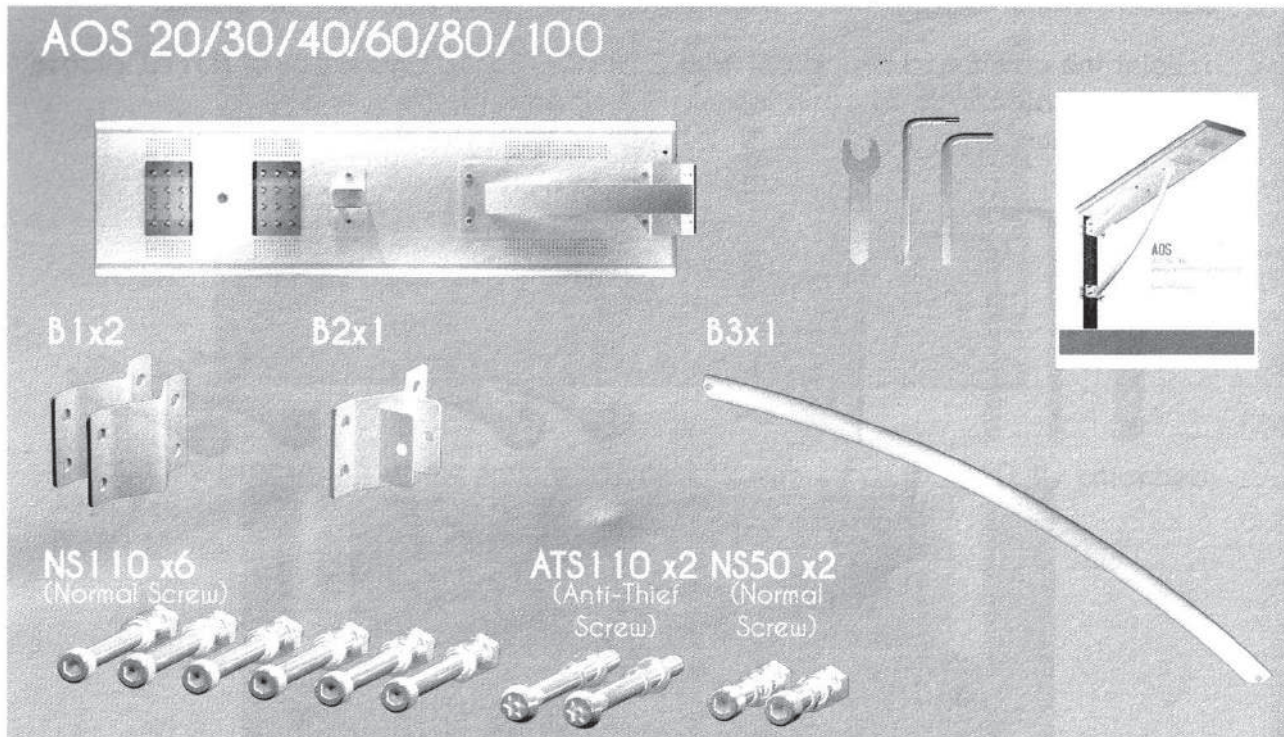



# CASTOR™

## Solar Area Street Light

### Installation

#### 2.4 Installation Guide:

##### Straight Type Installation:

Determine the poles position according to the max radiation and road condition, confirm installation height and distance by referring to AOS Specifications.

1. Joint the cover and bracket B1 with 2 pcs of AT5110 and 2 pcs of NS110, please keep a certain space to easily mount the unit onto the pole.  
(Refer to figure 1)

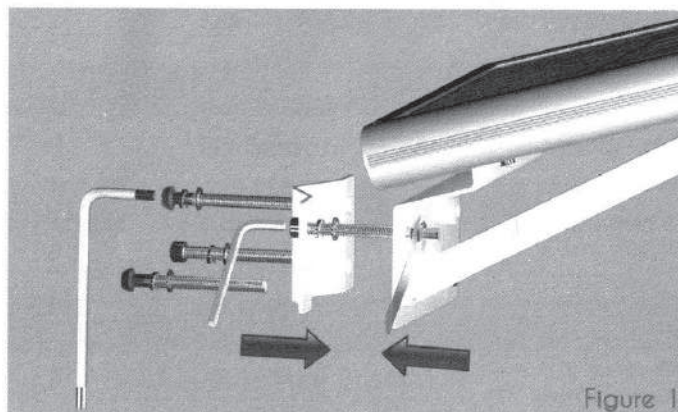
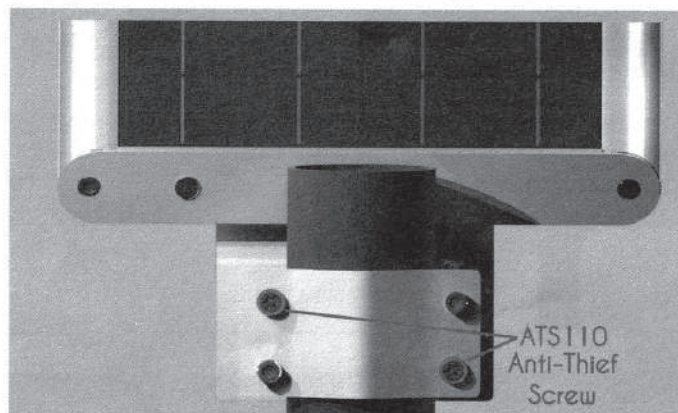

# CASTOR™

## Solar Area Street Light

### Installation

2. Mount AOS on the pole by fastening ATS110 and NS110.  
(Refer to figure 2)

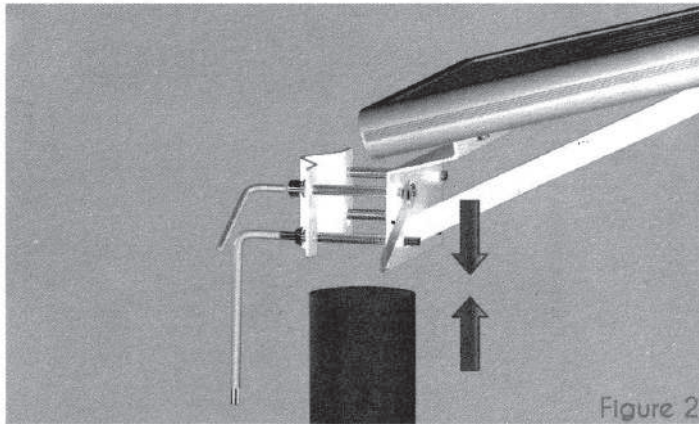

3. Joint the bracket B3 at the main body and B2 with 2 pcs of NS50, by attached Allen Key.  
(Refer to figure 3)

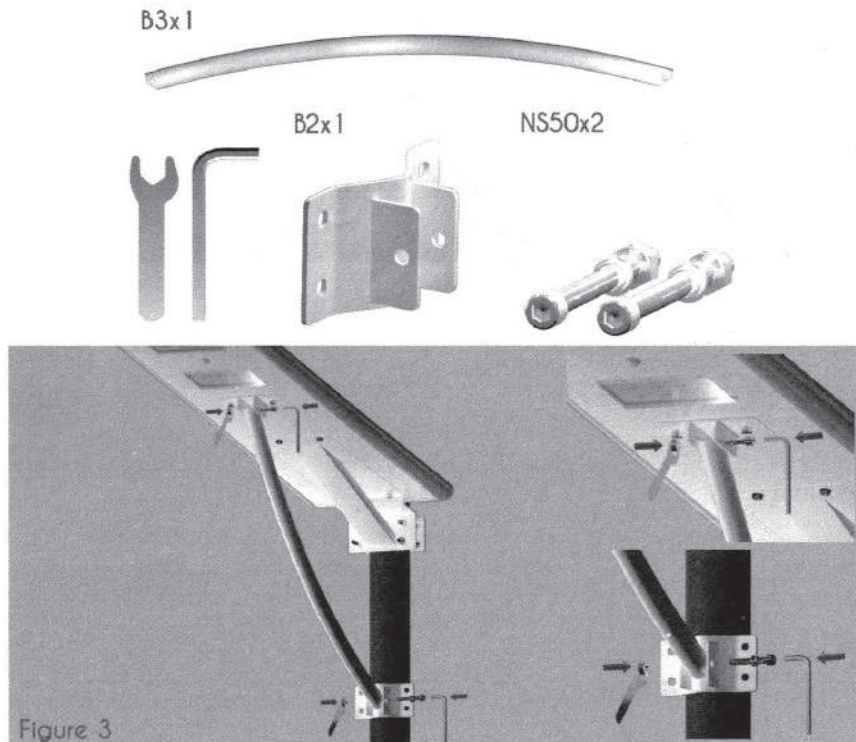



# CASTOR™

## Solar Area Street Light

### Installation

4. Joint the cover and bracket B1 with 2 pcs of ATS110 and 2 pcs of NS110, please keep a certain space to easily mount the unit onto the pole.  
(Refer to figure 4)

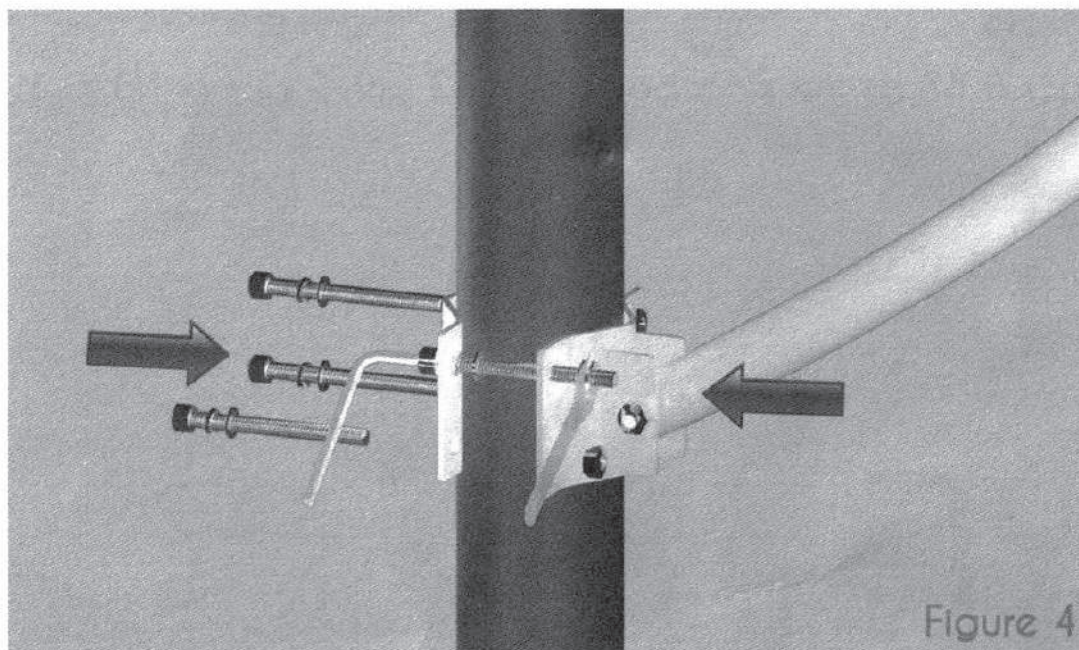
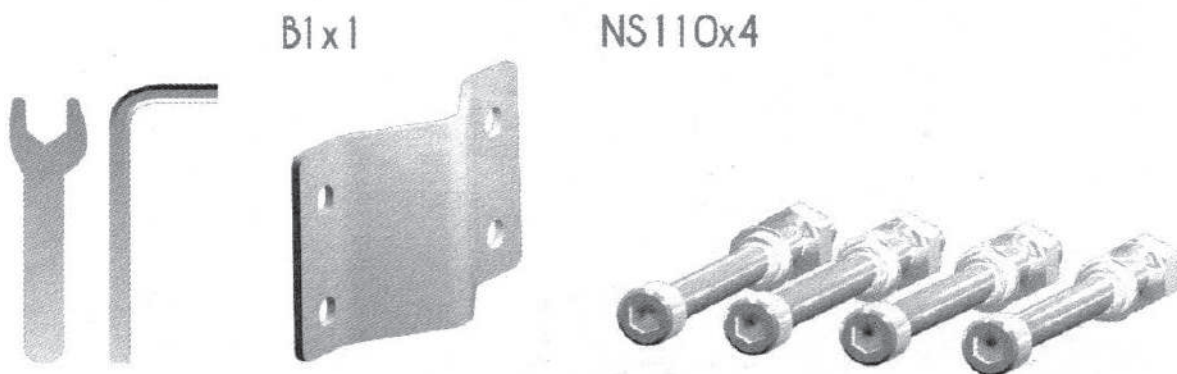

# CASTOR™

## Solar Area Street Light

### Installation

6. Press button to switch AOS ON.  
(Refer to figure 5)

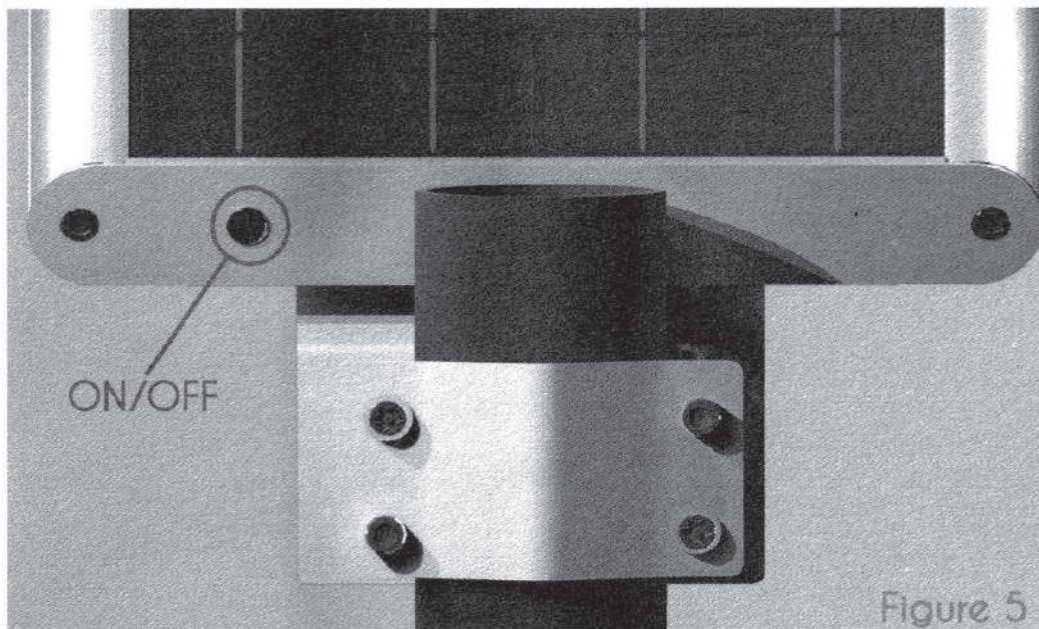

# CASTOR™

## Solar Area Street Light

### Packaging

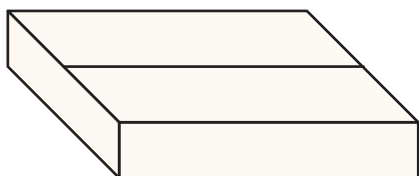

#### AVS-AI1-20W

- Packing Type: 1 Set/Box
- Packing Dimensions: 43 x 16 x 8"
- Packing Weight: 29 lb



#### AVS-AI1-40W

- Packing Type: 1 Set/Box
- Packing Dimensions: 52 x 16 x 8"
- Packing Weight: 47 lb

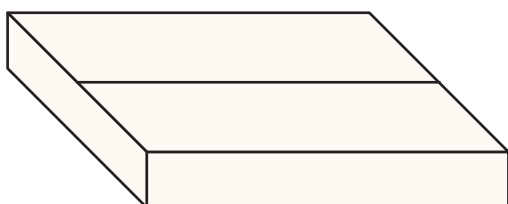

#### AVS-AI1-50W

- Packing Type: 1 Set/Box
- Packing Dimensions: 52 x 20 x 8"
- Packing Weight: 53 lb

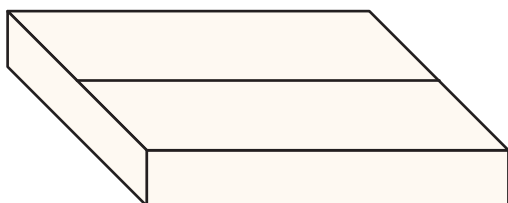

#### AVS-AI1-80W

- Packing Type: 1 Set/Box
- Packing Dimensions: 52 x 20 x 8"
- Packing Weight: 53 lb

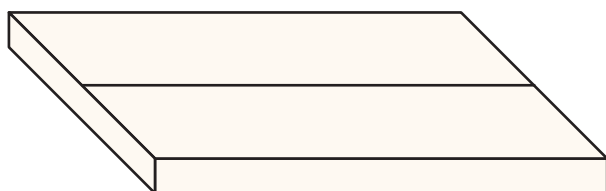

#### AVS-AI1-100W

- Packing Type: 1 Set/Box
- Packing Dimensions: 65 x 21 x 5"
- Accessory Box: 14 x 16 x 15"
- Packing Weight: 58 lb + 14 lb

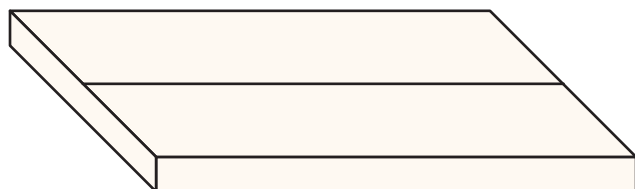

#### AVS-AI1-120W

- Packing Type: 1 Set/Box
- Packing Dimensions: 69 x 21 x 5"
- Accessory Box: 14 x 16 x 15"
- Packing Weight: 62 lb + 14 lb





# CASTOR™

## Solar Area Street Light

### Application



SOLAR AREA LIGHT

