



DC 60V Lithium-Ion Battery Power Inverter

FOR MODELS: IV60A00

INPUT: DC 60V, 8A

OUTPUT: AC 120V/60HZ, 300W

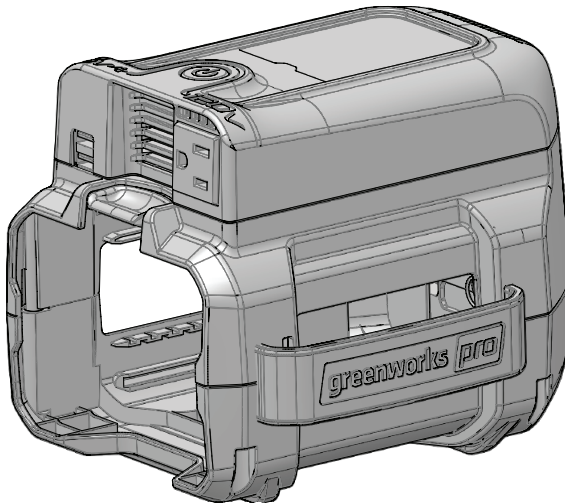

Owner's Manual

TOLL-FREE HELPLINE: 1-855-345-3934

www.GreenWorksTools.com

 Read all safety rules and instructions carefully before operating this tool.

CONTENTS

Contents	2
Product specifications.....	2
Important safety instructions	3
Protective features of the inverter.....	5
Working principles.....	6
Operation.....	7
Environmentally safe battery disposal.....	8
Troubleshooting	9
Warranty	10

PRODUCT SPECIFICATIONS

DC 60V POWER INVERTER

Output Voltage.....	120 Volt AC RMS 60Hz
Output USB	5VDC, 2.4A
Output Waveform.....	Modified Sine Wave (filtered)
Max. Efficiency	>90%
Rated Input Current.....	.8A
Input Voltage Range.....	45 to 64 volt DC
Low Voltage Shutdown	42 volt DC
Operation Temperature.....	-10C to 40C at 100% loading

IMPORTANT SAFETY INSTRUCTIONS



WARNING :

THIS MANUAL CONTAINS IMPORTANT INFORMATION REGARDING SAFETY, OPERATION, MAINTENANCE AND STORAGE OF THIS PRODUCT. BEFORE USE, READ AND UNDERSTAND ALL CAUTIONS, WARNINGS, INSTRUCTIONS AND PRODUCT LABELS, PLUS YOUR GREENWORKS'S BATTERY MANUFACTURER GUIDELINES. FAILURE TO DO SO COULD RESULT IN INJURY AND/OR PROPERTY DAMAGE.

To ensure reliable service, your power inverter must be installed and used properly. Please read the installation and operating instructions thoroughly prior to installation and use. Pay particular attention to the WARNING and CAUTION statements in this manual. The CAUTION statements advise against certain conditions and practices that may result in damage to your inverter. The WARNING statements identify conditions or practices that may result in personal injury. ***Read All Instructions Before Using This Power Inverter!***



WARNING :

TO REDUCE THE RISK OF FIRE, ELECTRIC SHOCK, EXPLOSION OR INJURY:

- Do not connect to AC distribution wiring.
 - Remove appliance plug from outlet strip or turn off inverter before working on the appliance. Multiple outlet power strips with switches and circuit breakers only interrupt power to the “hot” receptacle terminals. The “neutral” terminals remain powered with respect to the “ground” terminals.
 - Do not make any electrical connections or disconnections in areas designated as IGNITION PROTECTED.
 - This is not a toy - keep away from children.
 - DO NOT install object into air vents.
-



WARNING :

Reverse polarity connection will cause the unit to malfunction and may permanently damage the inverter.

CAUTIONS :

- Grounding the neutral will damage the inverter. Do not operate this inverter if it is wet. Do not install in engine compartment – please install in a well ventilated area.
 - This inverter is not tested for use with medical devices.
-



WARNING :

This device complies with Part 15 of the FCC Rules. Operation is subject to the following two conditions:

- This device may not cause harmful interference.
 - This device must accept any interference received, including interference that may cause undesired operation.
-

CAUTIONS :

Changes or modifications not expressly approved by the party responsible for compliance could void the user's authority to operate the equipment.

IMPORTANT SAFETY INSTRUCTIONS

POWER SOURCE REQUIREMENTS

The power source must be able to supply the necessary current to operate the load. The GreenWorks **60V battery** is the only DC source cannot connect to other DC source.



W A R N I N G :

Keep ventilation when using batteries.

Cannot mount the power inverter on other position, can just install on the GreenWorks battery pack.

CONNECTION TO LOAD

The inverter is equipped with a AC power receptacle. Plug the cord from the equipment you wish to operate into an AC receptacle. The green LED indicator lights to indicate that the inverter is functioning. Make sure the combined load requirement of your equipment does not exceed inverter's output rating.

The inverter is engineered to be connected directly to standard electrical and electronic equipment in the manner described above.

Do not connect the power inverter to household or RV AC distribution wiring.

Do not connect the power inverter to any AC load circuit in which the neutral conductor is connected to ground (earth) or to the negative of the DC (battery) source.

OPERATING ENVIRONMENT

For best operating results, the inverter should be placed on flat surface, such as the ground, car floor, or other solid surface. The inverter should only be used in locations that meet the following criteria:

DRY- Do not allow water and/or other liquids to come into contact with the power inverter.

COOL – Do not place the inverter on or near a heating vent or any piece of equipment which is generating heat above room temperature. Keep the inverter away from direct sunlight, if at all possible.

SAFE – Do not use the inverter near flammable materials or in any locations that may accumulate flammable fumes of gases.

PROTECTIVE FEATURES OF THE INVERTER

Your inverter monitors the following potentially hazardous conditions:

OVER TEMPERATURE PROTECTION – If the temperature inside the inverter is too high, the unit will automatically shut down. Allow the unit to cool for at least 15 minutes before restarting after a heat-related shutdown. Unplug unit while cooling.

LOW BATTERY VOLTAGE PROTECTION - This condition is not harmful to the inverter but could damage the power source. The inverter automatically shuts down when input voltage drops to 42 volts. When the condition is corrected, the unit may be restarted.

OVER VOLTAGE PROTECTION – The inverter will automatically shut down when the input voltage exceeds 64 volts DC.

OVERLOAD PROTECTION – The inverter will automatically shut down when the continuous draw exceeds rated watts.

SHORT CIRCUIT PROTECTION – The inverter will shut down. Remove the short circuit and restart the inverter after 5 minutes.

WORKING PRINCIPLES

HOW YOUR INVERTER WORKS

The inverter converts low voltage DC (Direct Current) from a Greenworks 60V lithium battery to standard 120 volt AC (Alternating Current) household power.

PRINCIPLE OF OPERATION

The inverter converts power in two stages.

- The first stage is a DC to DC conversion process that raises the low voltage DC at the inverter input to high volts DC.
- The second stage is the actual inverter stage that converts the high voltage DC into AC.

The DC-to-DC converter stage uses modern high frequency power conversion techniques that have replaced the bulky transformers found in less technologically-advanced models. The inverter stage uses advanced power MOSFET transistors in a full bridge configuration.

THE OUTPUT WAVEFORM

The AC output waveform of the **IV60A00-series** inverter is known as “modified sine wave”. It is a waveform that has characteristics similar to the sine wave shape of utility power. This type of waveform is suitable for most AC loads, including linear and switching power supplies used in electronic equipment, transformers, and motors. (See *Figure 1*).

The modified sine wave produced by the **IV60A00-series** inverter has an RMS (root mean square) voltage of 120 volts, which is the same as standard household power. Most AC voltmeters (both digital and analog) are sensitive to the average value of the waveform rather than the RMS value. They are calibrated for RMS voltage under the assumption that the waveform measured will be a pure sine wave. These meters will not read the RMS voltage of a modified sine wave correctly. They will read about 20 to 30 volts low when measuring the output of the inverter. **For accurate measurement of the output voltage of this unit, use a true RMS reading voltmeter.**

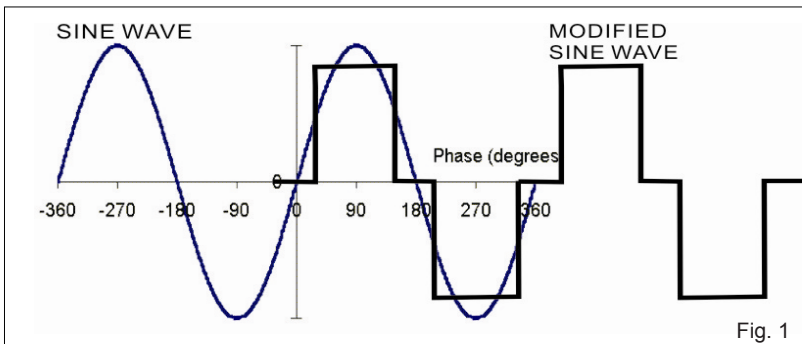
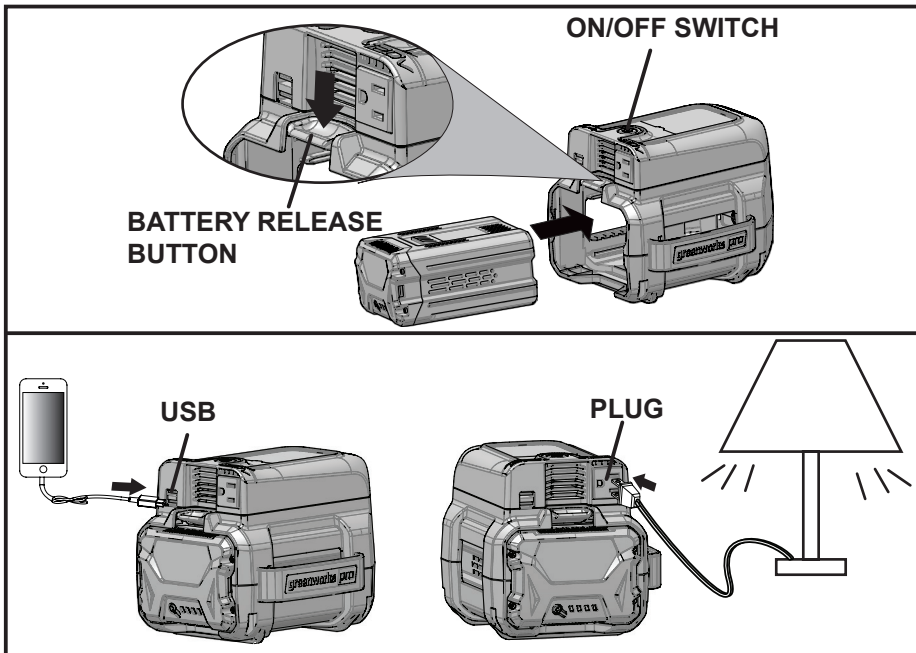

Fig. 1

OPERATION INSTRUCTIONS

NOTE: This product requires no assembly.

1. Insert the battery pack into the power inverter.
2. Press the switch to ON position.
3. Connect the plug or USB to the receptacle.



The LED lights indicate the working condition of the power inverter as follows:

Work condition	Green	Red	
Normal	●	○	
High-voltage protection	○	○	
Overload protection	○	●	
Battery error	○	●	
Low battery voltage	⦿	○	
Short-circuit protection	○	⦿	red light will flash in intervals of 4
Low-voltage protection	○	⦿	red light will flash in intervals of 5
Temperature protection	○	⦿	red light will flash in intervals of 6

ENVIRONMENTALLY SAFE BATTERY DISPOSAL



The following toxic and corrosive materials are in the batteries used in this tool battery pack:
Li-ion, a toxic material.



WARNING :

All toxic materials must be disposed of in a specified manner to prevent contamination of the environment. Before disposing of damaged or worn out Lithium-ion battery packs, contact your local waste disposal agency, or the local Environmental Protection Agency for information and specific instructions. Take the batteries to a local recycling and/or disposal centre, certified for Li-ion disposal.



WARNING :

If the battery pack cracks or breaks, with or without leaks, do not recharge it and do not use. Dispose of it and replace with a new battery pack. **DO NOT ATTEMPT TO REPAIR IT!** To avoid injury and risk of fire, explosion, or electric shock, and to avoid damage to the environment:

- Cover the battery's terminals with heavy-duty adhesive tape.
 - DO NOT attempt to remove or destroy any of the battery pack components.
 - DO NOT attempt to open the battery pack.
 - If a leak develops, the released electrolytes are corrosive and toxic. DO NOT get the solution in the eyes or on skin, and do not swallow it.
 - DO NOT place these batteries in your regular household trash.
 - DO NOT incinerate.
 - DO NOT place them where they will become part of any waste landfill or municipal solid waste stream.
 - Take them to a certified recycling or disposal centre.
 - Have servicing performed by a qualified repair person using only identical replacement parts. This will ensure that the safety of the product is maintained.
-

TROUBLESHOOTING

PROBLEM	POSSIBLE CAUSE	SOLUTION
Some AC appliances won't start.	The power needed to start some AC appliances may be as much as 2 to 8 times its continuous wattage requirements.	Read the information panel on each AC appliance carefully to accurately determine the tool's input wattage.
"BUZZING" sound in audio systems.	The power supply in the electronic device does not adequately filter the modified sine wave produced by the inverter.	Use a higher quality sound system that incorporates a higher quality power amplified supply.
Television interference.	The inverter is shielded to minimize interference with TV signals. The problem may not be with the inverter. However, in some instances, some interference may still be visible, particularly with weak TV signals.	Position the inverter as far as possible from the television, the antenna and the antenna cables. <u>Use an extension cable, if necessary.</u>
		Adjust the orientation of the inverter, the antenna cables and the TV power cord to minimize interference.
		Make sure that the antenna feeding the television provides an adequate ("snow free") signal and that high quality, shielded antenna cable is used.
		Do not operate high-power appliances or tools when you are watching TV.

WARRANTY



Greenworks hereby warrants this product, to the original purchaser with proof of purchase, for a period of four (4) years against defects in materials, parts or workmanship. Greenworks, at its own discretion will repair or replace any and all parts found to be defective, through normal use, free of charge to the customer. This warranty is valid only for units which have been used for personal use that have not been hired or rented for industrial/commercial use, and that have been maintained in accordance with the instructions in the owners' manual supplied with the product from new.

ITEMS NOT COVERED BY WARRANTY:

1. Any part that has become inoperative due to misuse, commercial use, abuse, neglect, accident, improper maintenance, or alteration; or
2. The unit, if it has not been operated and/or maintained in accordance with the owner's manual; or
3. Normal wear, except as noted below;
4. Routine maintenance items such as lubricants, blade sharpening;
5. Normal deterioration of the exterior finish due to use or exposure.

HELPLINE:

Warranty service is available by calling our toll-free helpline, at **1-855-345-3934**.

TRANSPORTATION CHARGES:

Transportation charges for the movement of any power equipment unit or attachment are the responsibility of the purchaser. It is the purchaser's responsibility to pay transportation charges for any part submitted for replacement under this warranty unless such return is requested in writing by Greenworks.

USA address:

Greenworks Tools
P.O. Box 1238
Mooresville, NC 28115

Canadian address:

Greenworks Tools Canada Inc.
1110 Stellar Drive Unit 102
Newmarket, ON, L3Y 7B7