

swisherinc.com

OWNER'S MANUAL

22511

Commercial Pro Truck Spreader

Starting Serial #: L222-306001

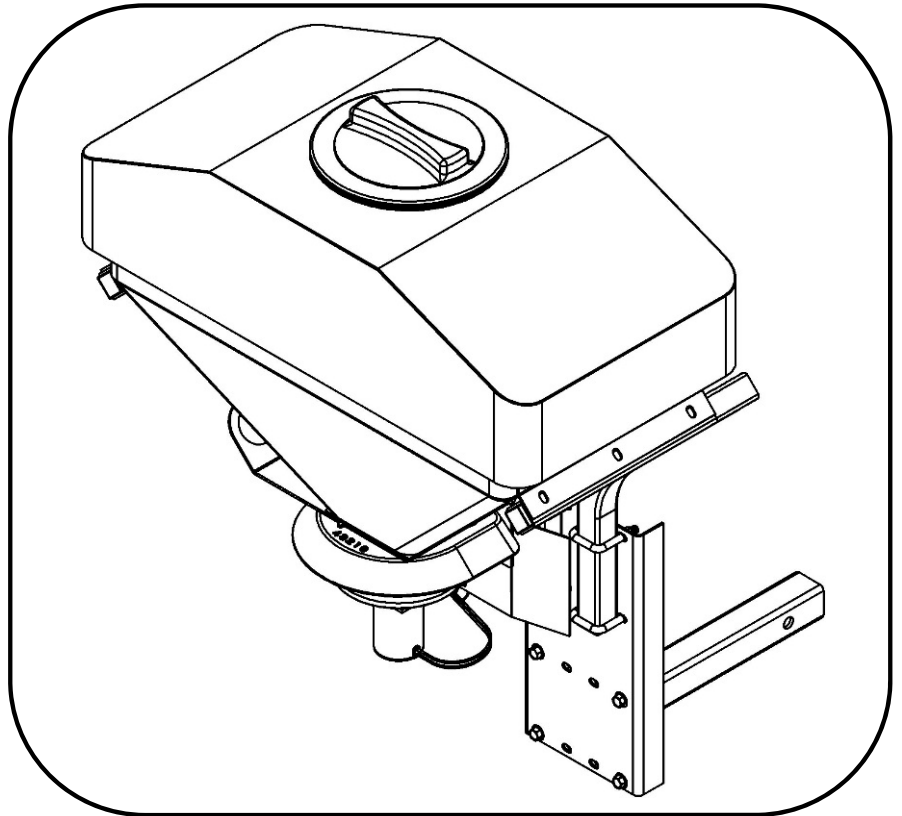

SWISHER®



CHANGING YOUR LANDSCAPE SINCE 1945

IMPORTANT
Read and follow all
Safety Precautions
and Instructions
Before Operating this
Equipment.

SWISHER
1602 CORPORATE DRIVE, WARRENSBURG, MISSOURI 64093
PHONE 660-747-8183 FAX 660-747-8650

Made In The
USA
of US and Global Parts

11/28/2022

LIMITED WARRANTY

The manufacturer's warranty to the original consumer purchaser is: This product is free from defects in materials and workmanship for a period of one (1) year from the date of purchase by the original consumer purchaser. We will repair or replace, at our discretion, parts found to be defective due to materials or workmanship. This warranty is subject to the following limitations and exclusions:

1. Limitation This warranty applies only to products which have been properly assembled, adjusted, and operated in accordance with the instructions contained within this manual. This warranty does not apply to any product of Swisher that has been subject to alteration, misuse, abuse, improper assembly or installation, shipping damage, or to normal wear of product.
2. Exclusions Excluded from this warranty are normal wear, normal adjustments, and normal maintenance.

In the event you have a claim under this warranty, you must return the product to an authorized service dealer. All transportation charges, damage, or loss incurred during transportation of parts submitted for replacement or repair under this warranty shall be borne by the purchaser. Should you have any questions concerning this warranty, please contact us toll-free at 1-800-222-8183. The model number, serial number, date of purchase, and the name of the authorized Swisher dealer from whom you purchased the product will be needed before any warranty claim can be processed.

THIS WARRANTY DOES NOT APPLY TO ANY INCIDENTAL OR CONSEQUENTIAL DAMAGES AND ANY IMPLIED WARRANTIES ARE LIMITED TO THE SAME TIME PERIODS STATED HEREIN FOR ALL EXPRESSED WARRANTIES. Some states do not allow the limitation of consequential damages or limitations on how long an implied warranty may last, so the above limitations or exclusions may not apply to you. This warranty gives you specific legal rights and you may have other rights, which vary from state-to-state. This is a limited warranty as defined by the Magnuson-Moss Act of 1975.

SAFETY PRECAUTIONS



This Safety Alert Symbol indicates important messages in this manual. When you see this symbol, carefully read the message that follows and be alert to the possibility of personal injury.

Read this manual completely. Failure to observe the following safety instructions could result in serious injury or death.

- Read the manual. Learn to operate the attachment safely.
- **Do not touch the motor while in operation. The vibrations created by the motor could cause bodily harm.**
- Keep the operating speed low!
- Allow only responsible adults who are familiar with these instructions to operate this attachment. Never allow children to operate this attachment.
- Be sure the area is clear of other people before operating. Children are often attracted to the attachment and the operating activity. **Never assume that children will remain where you last saw them.** Keep children under the watchful care of another responsible adult.
- Watch for traffic when operating near or while crossing roadways.
- Do not operate the attachment if it has been dropped or damaged in any manner. Repair as necessary.
- Stop and inspect the attachment if you strike an object. Repair as necessary before restarting.
- Dress properly. Do not operate when barefoot or wearing open sandals.
- Do not operate the attachment while under the influence of alcohol or drugs.
- Never tamper with safety devices. Check their proper operation regularly.
- Operate attachments up and down slopes. There is a significant risk of overturns when operating across slopes.
- **Never make adjustments or repairs with the vehicle engine running.**
- Follow the vehicle manufacturers safe operating procedures.

Recommended Tools For Assembly:

- Socket Wrench
- 9/16" Socket
- 1/2" Socket
- 9/16" Box End Wrench
- 1/2" Box End Wrench
- Small Flat Head Screwdriver
- Pliers

Item #	Part #	Description
1	10192	Washer - Nylon Retainer 5/16
2	10111*	Bracket - Motor Support, Upper
3	10112*	Gate - Hopper
4	22605	Washer - USS Flat, 1/2
5	7825Z	Bushing
6	22610	Spring - Gate
7	22606	Washer - 5/16 X 1 1/4 OD
8	10113	Deflector
9	22607	Washer - USS Flat, 5/16
10	22608	Bolt - 5/16-18 X 1 1/2 HCC
11	22609	Nut - Nyloc 5/16-18
12	22509	Hopper

Step 1: Hopper Gate Assembly

- Assemble the Deflector (8), Hopper Gate (3) and Upper Motor Support Bracket (2) together using four 5/16-18 X 1 1/2" Bolts (10), four 5/16" Washers (9), four 5/16" X 1 1/4" Washers (7), four Springs (6), four Bushings (5), four 1/2" Washers (4) and four 5/16" Nylon Retainer Washers (1) in the order shown.
- Tip: Use the 5/16" Nylon Retainer Washers (1) to hold the assembly together for the next step. The four slots of the Hopper Gate (3) need to be aligned with the Bushings (5) so it can freely slide.

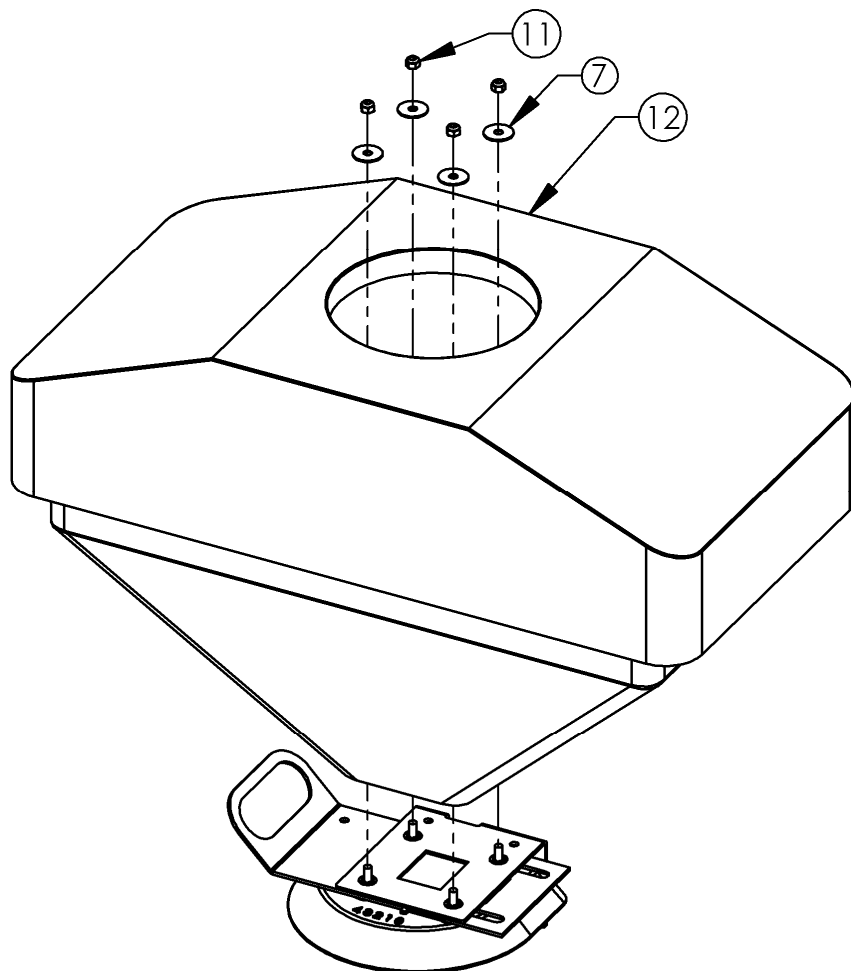
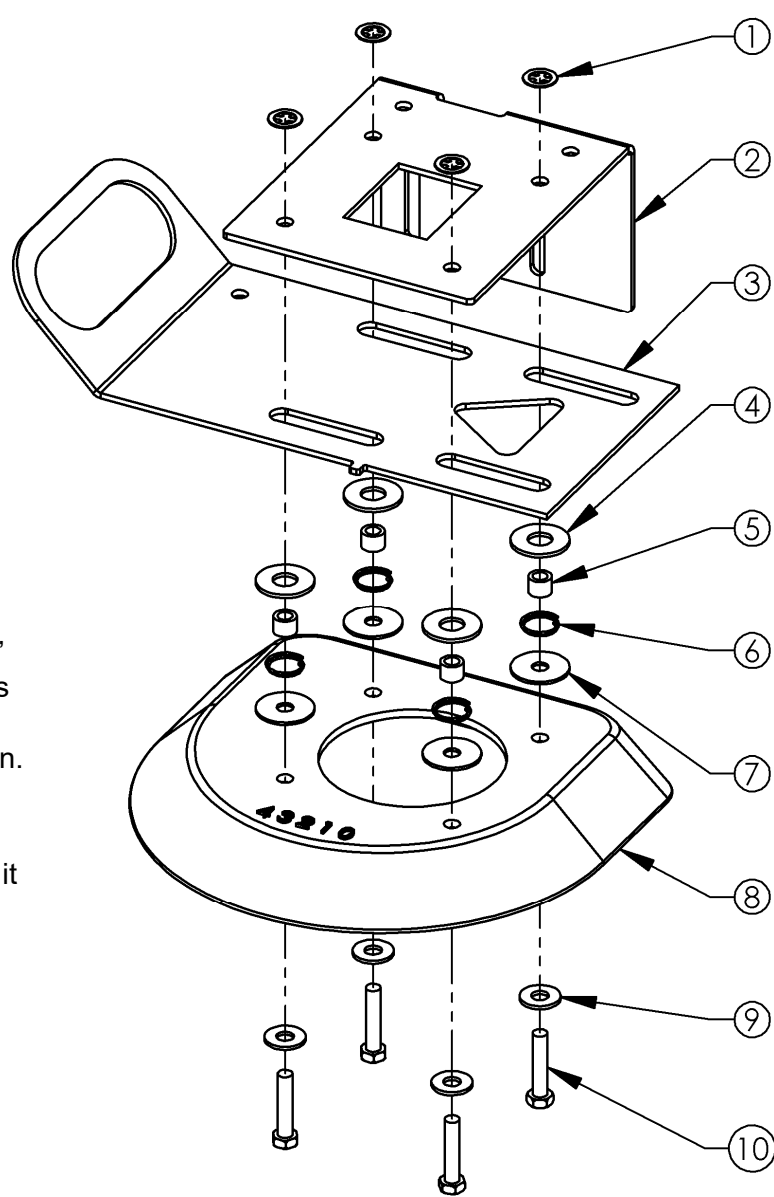

Step 2: Attaching the Hopper Gate Assembly

- Using a 1/2" socket wrench and a 1/2" box end wrench, attach the assembly made in Step 1 to the Hopper (12) by sliding the four 5/16-18 X 1 1/2" Bolts (10) through the holes in the bottom of the Hopper (12). Place a 5/16" X 1 1/4" Washer (7) over each 5/16-18 X 1 1/2" Bolt (10) and securely fasten the assembly with the 5/16-18 Nuts (11).
- Tip: Make sure the Hopper Gate (3) is able to slide smoothly. If it doesn't slide smoothly, the Bushings (5) installed in Step 1 may not be correctly aligned. Check to make sure the Bushings (5) are correctly aligned with the four slots of the Hopper Gate (3) by pressing down on the sides of the Hopper Gate (3). You should feel resistance from the Springs (6), indicating proper alignment.

Step 3: Motor Assembly

- Tip: Items 3, 4 and 5 are preassembled.
- Remove the Snap Ring (1) from the Motor (5) using a small flat head screwdriver. Slide the Spinner Disc (2) onto the Motor Shaft and secure with the Snap Ring. If the snap ring is difficult to install by hand, use a pair of pliers to install it.
- Insert the 5/16-18 X 1" Carriage Bolts (6) through the square holes of the Lower Motor Bracket (4), through the slots of the Upper Motor Bracket (2 on pg 4) and through the Spreader Shield (8). The guide on the Lower Motor Bracket (4) will slide up through the slot in the Upper Motor Bracket (2 on pg 4). Fasten the 5/16-18 X 1" Carriage Bolts (6) using the T-Knobs (9) and tighten securely.
- Route the wires of the Motor (5) through the Black Zip Tie (7).

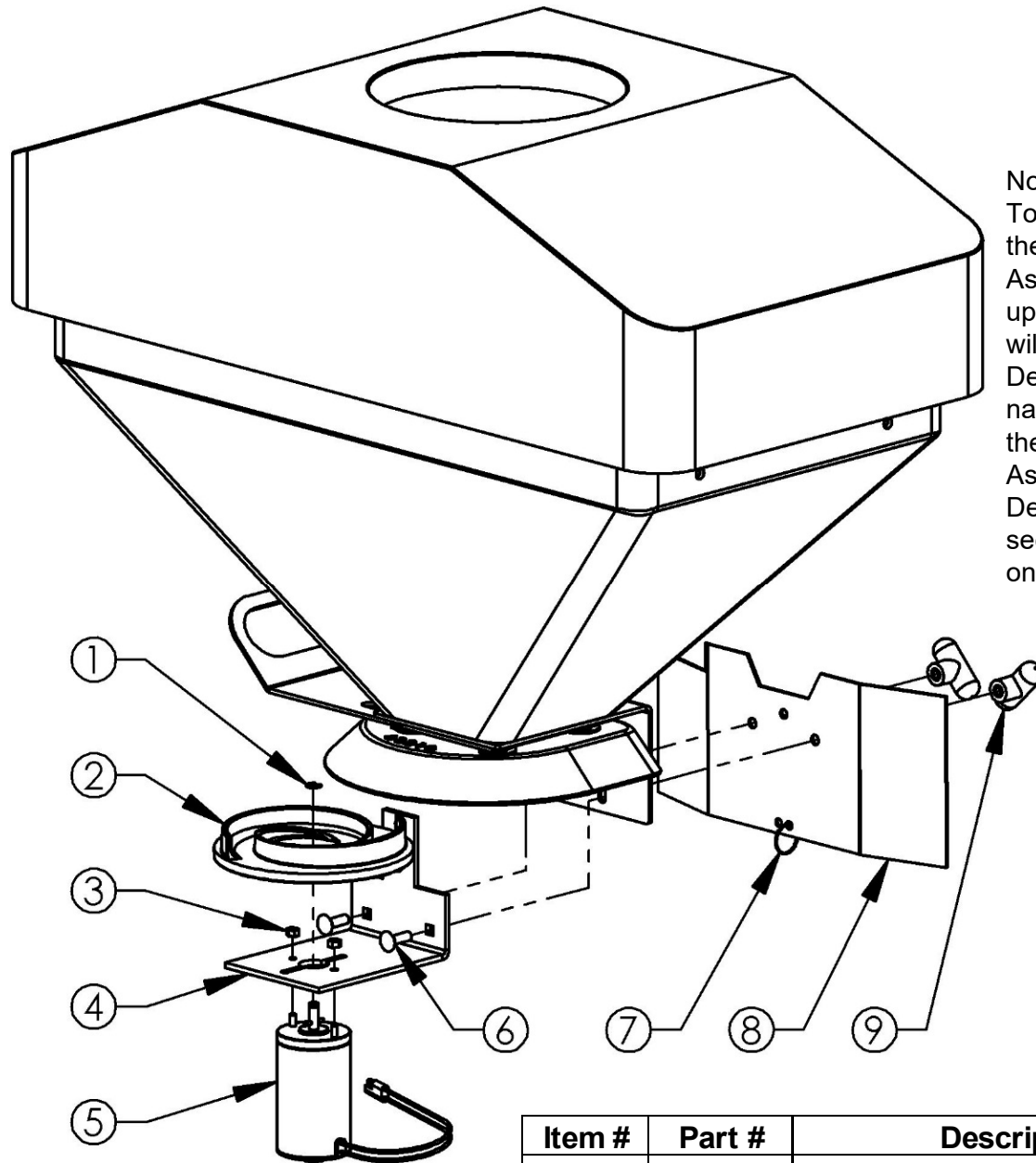

Note:
To control the spread width, loosen the T-Knobs (9) and slide the Motor Assembly up or down. In the uppermost adjustment the material will be deflected down by the Deflector (8 on pg 4) resulting in a narrower spread width. To increase the spread width, slide the Motor Assembly down and away from the Deflector. For more information, see the Material Spreading Chart on pg 11.

Item #	Part #	Description
1	N/A	Snap Ring (Included w/ Motor)
2	10118	Disc - Spinner
3	12564	Nut - Nyloc, 10-32
4	10114*	Bracket - Motor Support, Lower
5	19913	Motor - Spreader, 12V
6	10197	Bolt - Carriage 5/16-18 X 1
7	AS021	Tie, Black 5 1/2"
8	10117*	Shield - Spreader
9	3844	Knob - T, 5/16-18

When ordering replacement parts
*USE PAINT CODE: TK=BLACK

Step 4: Vibrator Motor Assembly

- Assemble the Spreader Vibrator (4) as shown with the Mount Plate (1) and Bolts (2) on the inside of the Hopper (5).
- Tighten the Nuts (3) securely using a 9/16" socket.

Item #	Part #	Description
1	22426*	Plate - Vibrator Mount
2	10501	Bolt - Carriage 3/8-16 X 1 1/4
3	NB779	Nut - Serrated Flange, 3/8-16
4	22427	Vibrator - Spreader, 80lb
5	-	Existing Hopper (Not Included)

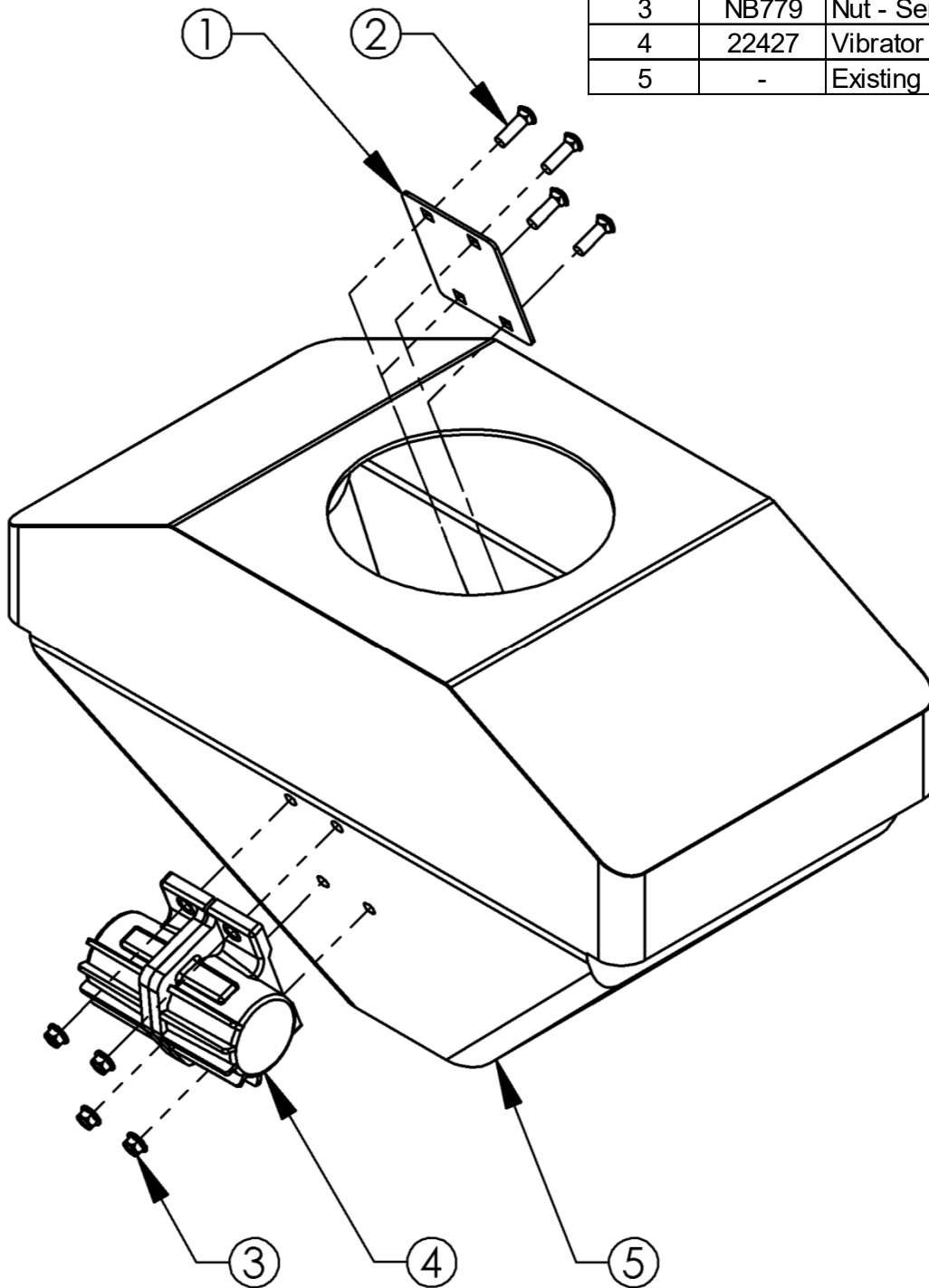

Spreader Vibrator
shown on a Swisher
ATV Spreader.

Item #	Part #	Description
1	10176	Lid - Hopper
2	22609	Nut - Nyloc 5/16-18
3	22606	Washer - 5/16 X 1 1/4 OD
4	10979*	Support - RH Weldment
5	10976*	Support - LH Weldment
6	NB501	Bolt - 5/16-18 X 1
7	22607	Washer - USS Flat, 5/16
8	H1P	Plug - 1 1/2 Cap, Square

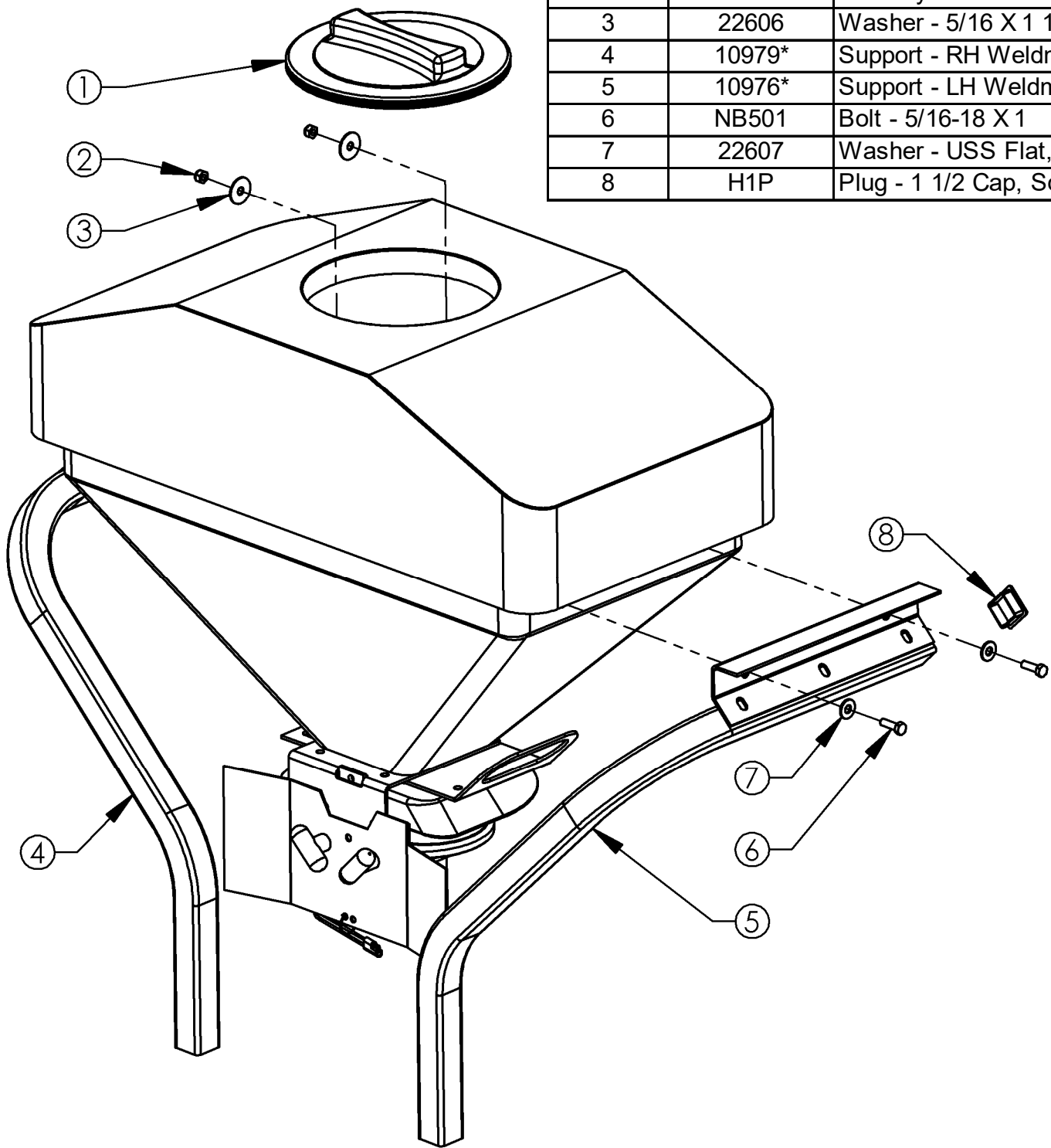

Step 5: Attaching the Hopper Support Tubes

- Attach the Support Tube Weldments (4 & 5) to the Hopper (12 on pg 4) by inserting the 5/16-18 X 1" Bolts (6) through the smaller 5/16" Washers (7) and weldment, and into the holes on the side of the Hopper (12 on pg 4) as shown.
- Place a 5/16 X 1 1/4" Washer (3) over each 5/16-18 X 1" Bolt (6) on the inside of the Hopper and thread the 5/16-18 Nuts (2) onto the 5/16-18 X 1" Bolts (6), tightening securely using a 1/2" socket wrench and 1/2" box end wrench.
- Tip: Item 8 is preassembled into the tube weldments.

When ordering replacement parts

*USE PAINT CODE: TK=BLACK

Item #	Part #	Description
1	9855	Bolt - U, Sq 3/8-16 X 1 5/8 X 2 3/4
2	20135*	Plate - Height Adjustment
3	13964	Bolt - Serrated Flange 3/8-16 X 1
4	NB182	Nut - Nyloc 3/8-16
5	20132*	Weldment - Mount
6	NB272	Washer - SAE Flat 3/8

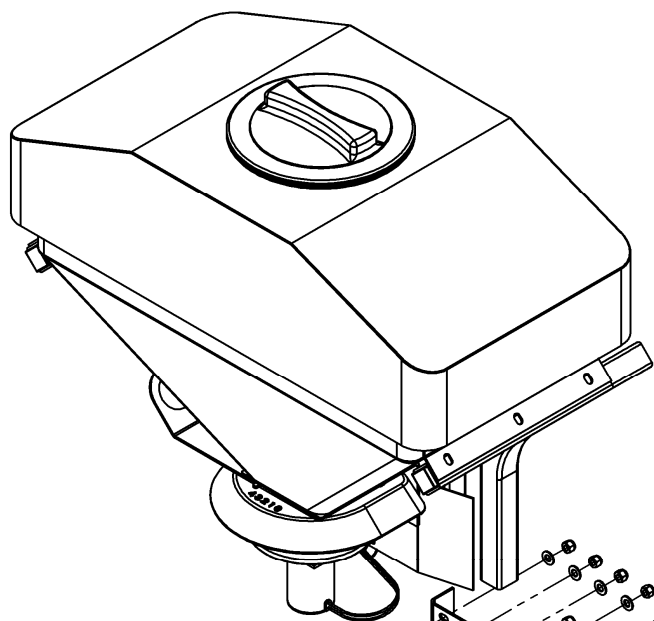

Tip: Find an assistant to help when attaching or removing the Truck Spreader. Care must be taken while lifting to avoid personal injury or equipment damage.

2" X 2" Receiver Hitch Compatible

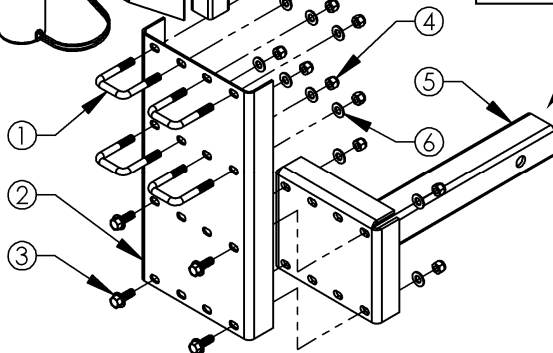

Step 6: Assembling the Hitch Mount

- Using 9/16" socket wrench and a 9/16" box end wrench, attach the Mount Weldment (5) to the Height Adjustment Plate (2) using four 3/8-16 X 1" Serrated Flange Bolts (3), four 3/8" Washers (6) and four 3/8-16 Nuts (4), tightening securely.
- Loosely assemble the four U-Bolts (1) to the Height Adjustment Plate (2) using eight 3/8" Washers (6) and eight 3/8-16 Nuts (4).
- Insert the Right and Left Support Tube Weldments (4 & 5 on pg 6) through the U-Bolts (1) and tighten the 3/8-16 Nuts (4) securely using a 9/16" socket wrench.

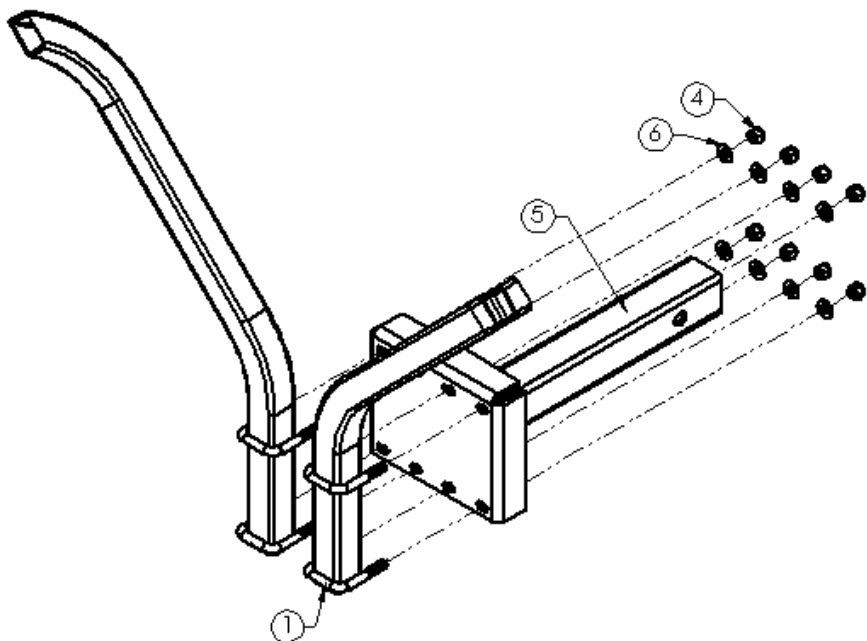

Alternate Hitch Assembly for Lower Height:

- Using 9/16" socket wrench and a 9/16" box end wrench loosely assemble the four U-Bolts (1) to the Mount Weldment (5) using eight 3/8" Washers (6) and eight 3/8-16 Nuts (4).
- Insert the Right and Left Support Tube Weldments (4 & 5 on pg 6) through the U-Bolts (1) and tighten the 3/8-16 Nuts (4) securely using a 9/16" socket wrench.

Step 7: Wiring Harness Assembly

- Connect the Motor (1) and Vibrator (2) to the 12V Wiring Harness (3) by interlocking the molded connectors.
- Tip: Use the Black Zip Tie (7 on pg 5) to secure the wires of the Motor (1) to the Spreader Shield (8 on pg 5).
- To turn on the Motor and Vibrator, plug in the 12V plug into your vehicle's 12V power outlet.
- See Optional Harness Extension instructions below if the 12V plug will not reach the 12V outlet in your vehicle
- Use the supplied Convoluted Tubing (not shown) to protect the harness.
- It is recommended to secure the harness using the supplied Zip Ties (not shown) as you route wires to your vehicle's 12V outlet.

Item #	Part #	Description
1	19913	Motor - Spreader, 12V
2	22427	Vibrator - Spreader, 80lb
3	22510	Harness - Wiring, 12V
4	22135	Harness - Wiring, 96"

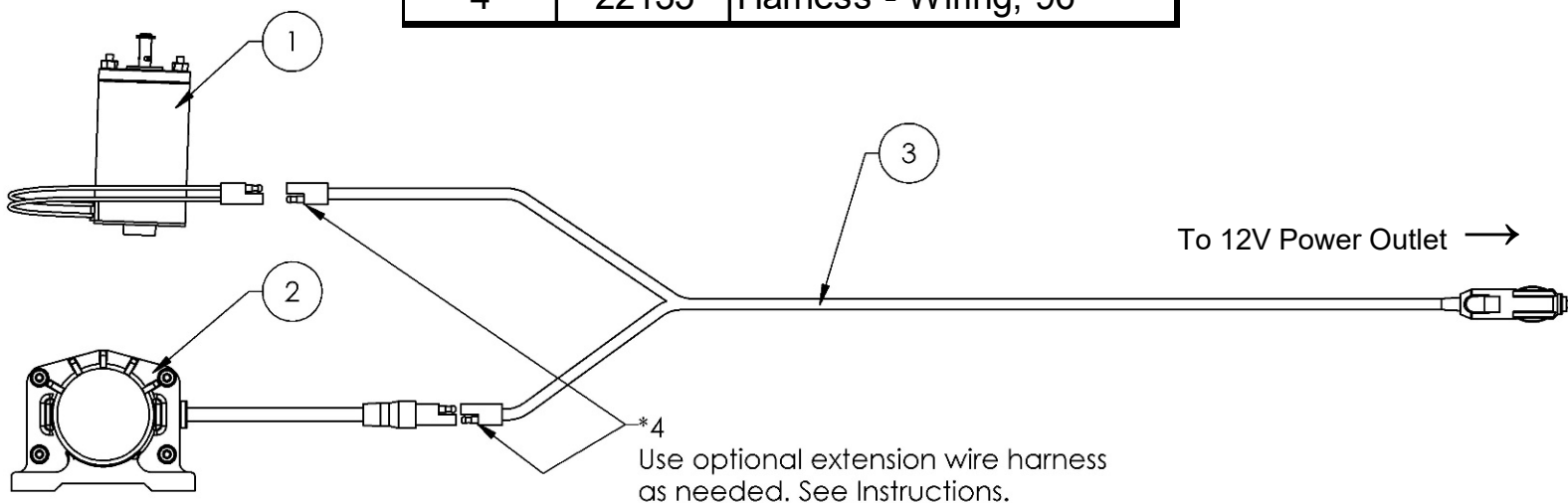

Optional: Wiring Harness Extension

- If the standard harness length is not long enough to reach the 12V outlet in your vehicle, use the supplied 96" extension harness.
- To Install the extension harnesses, plug the molded connectors of each extension harness into molded connectors between the motor, vibrator, and the 12V plug.
- Be sure to match the wire colors when connecting the molded plugs.
- It is recommended to secure the harness as you route wires to your vehicle's 12V outlet.

Material Spreading Chart

(Calibrated at 4 mph Ground Speed)

Product	Setting 1 lbs/Acre	Setting 2 lbs/Acre	Setting 3 lbs/Acre	Setting 4 lbs/Acre
Fertilizer	41 @ 4 mph	169 @ 4 mph	N/A	N/A
	20 @ 8 mph	84 @ 8 mph	N/A	N/A
Rock Salt	N/A	N/A	226 @ 4 mph	352 @ 4 mph
	N/A	N/A	113 @ 8 mph	176 @ 8 mph
Dry Sand	151 @ 4 mph	536 @ 4 mph	N/A	N/A
	75 @ 8 mph	268 @ 8 mph	N/A	N/A
Barley	N/A	56 @ 4 mph	170 @ 4 mph	N/A
	N/A	28 @ 8 mph	85 @ 8 mph	N/A
Oats	N/A	82 @ 4 mph	288 @ 4 mph	N/A
	N/A	41 @ 8 mph	144 @ 8 mph	N/A
Red Fescue	N/A	53 @ 4 mph	N/A	N/A
	N/A	26 @ 8 mph	N/A	N/A

- The above Spreader Chart settings are based off of a 10' spread width. Always trial test the application rate.
- Depending on the material you are spreading, the spread width could be higher or lower than what is shown.
- All measurements are taken with the Motor Assembly at the furthest setting from the Deflector (see pg 5).
- Formula for calibration of other products not listed above:

$$\frac{\text{Flow Rate (lbs/min)}}{\text{Coverage (sq-ft/min)}} \times \frac{\text{lbs/Acre}}{43,560 \text{ (sq-ft in 1 Acre)}}$$

Flow Rate (lbs/min): Material (lbs/min) that flows through selected hopper gate setting per minute (Motor Assembly removed, see pg 5).

Coverage (sq-ft/min): Material spread width (trial test required) multiplied by the distance traveled per minute (4 mph = 352 ft/min; 3 mph = 264 ft/min; 2 mph = 176 ft/min; 1 mph = 88 ft/min).

Helpful Tips

- Read Owner's Manual before use and be sure to follow all safety label precautions provided on the Spreader Hopper.
- Always use ONLY CLEAN DRY MATERIAL and be sure to remove all unused material from the Hopper after each use. Damp materials will cause material flow problems and material freezing problems in cold temperatures.
- Be sure material is free of foreign matter such as packaging etc.
- Some materials may jam the Hopper Gate at lower settings so it may be necessary to use a larger setting and increase your mph to compensate for the increased material flow rate. Increasing your ground speed from 4 mph to 8 mph will decrease your application rate per acre by half if the same setting is used at both speeds.
- Light seed such as Kentucky Blue Grass can be mixed with a seed such as clover to aid in material flow at a 50/50 mix.
- Increased material density per acre can be achieved by adjusting the Motor Assembly closer to the Deflector and Hopper Gate. This accomplishes a narrower spread width, providing more lbs/sq-ft of material.
- Do not spread light seed in windy conditions as poor coverage will result.
- Proper material coverage is achieved with the greatest satisfaction by covering the desired area twice at half the recommended application rate indicated by the manufacturer of the material. Once by traveling length ways then by traveling cross ways to account for any underlap issues. The adjustment of the application rate can be made either by adjusting the Hopper Gate to a lesser setting or by increasing the ground speed of the application vehicle.
- When using the Spreader for salt/ice melts, fertilizer or other corrosive materials it is imperative that the Spreader is thoroughly cleaned to prevent corrosion causing premature failure of the product.

SWISHER®

swisherinc.com

OWNER'S MANUAL

22511

Commercial Pro
Truck Spreader

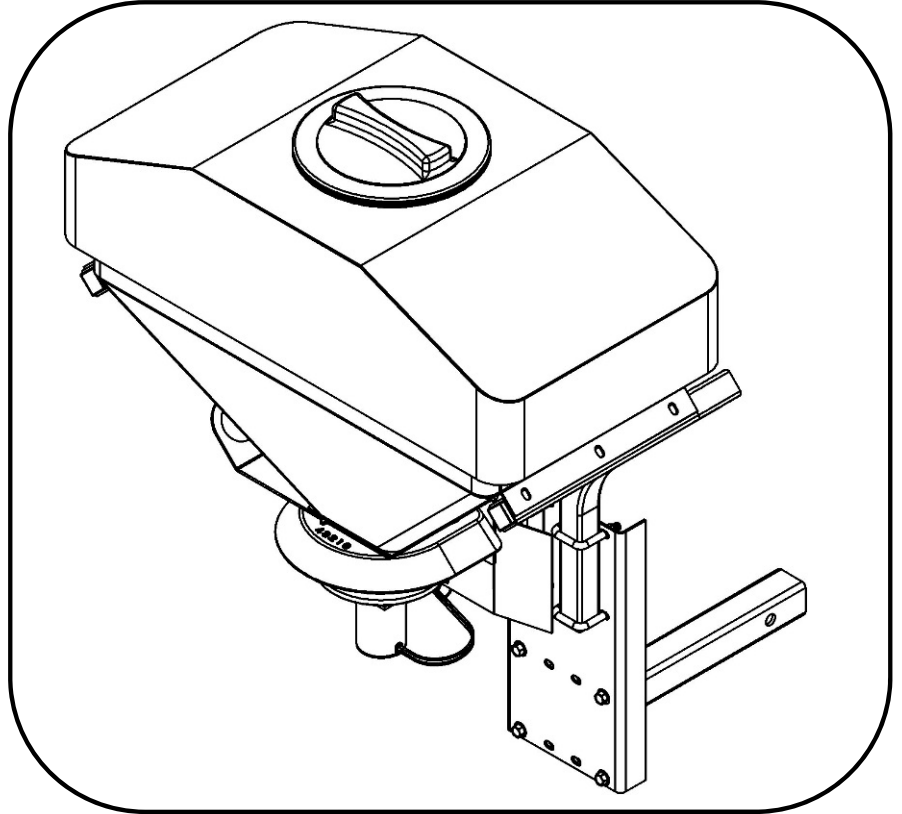

WHEN ORDERING PARTS, PLEASE HAVE THE
FOLLOWING INFORMATION AVAILABLE:

- * PRODUCT - _____
- * SERIAL NUMBER - _____
- * MODEL NUMBER - _____
TYPE - _____
- * PART NUMBER WITH PAINT CODE
* PART DESCRIPTION

TELEPHONE - 1-800-222-8183

FAX - 1-660-747-8650

swisherinc.com

SWISHER
1602 CORPORATE DRIVE, WARRENSBURG, MISSOURI 64093
PHONE 660-747-8183 FAX 660-747-8650

Made In The
USA
of US and Global Parts