



# ***Owner's Manual***

## **Original Instructions**

Window Type Air Conditioner

Thank you for choosing our product.  
Please read this Owner's Manual carefully before operation and retain it for future reference.  
If you have lost the Owner's Manual, please contact the local agent or visit [www.gree.com](http://www.gree.com) or send an email to [global@cn.gree.com](mailto:global@cn.gree.com) for the electronic version.



GJC14BM-A3NRNC5A  
GJC14BM-A3NRND2A  
GJC18BM-D3NRNC5A  
GJC18BM-D3NRND2A  
GJC18BY-D3NRNC5C  
GJC18BY-D3NRND2C

## Contents

### Operation and Maintenance

#### Operation Notices

---

Safety Precautions.....	1
Precautions.....	4
Parts Name.....	5

#### Operation Guide

---

Function and Control.....	6
Introduction of remote controller.....	9
Instruction for fan direction adjusting.....	12

#### Maintenance

---

Clean and Maintenance.....	13
----------------------------	----

#### Malfunction

---

Malfunction analysis.....	14
---------------------------	----

### Installation

#### Installation Notice

---

Installation and Maintenance.....	17
Preparation before installation.....	19
Window Types and Requirements..	22

#### Installation

---

Installation procedure.....	21
-----------------------------	----

## READ THIS MANUAL

Inside you will find many helpful hints on how to use and maintain your air conditioner properly. Just a little preventive care on your part can save you a great deal of time and money over the life of your air conditioner. You'll find many answers to common problems in the chart of troubleshooting tips. If you review our chart of Troubleshooting Tips first, you may not need to call for service at all.

### CAUTION

Contact the authorized service technician for repair or maintenance of this unit.

Contact the installer for installation of this unit.

The air conditioner is not intended for use by young children or infirm persons without supervision.

Young children should be supervised to ensure that they do not play with the air conditioner.

If the power cord is to be replaced, replacement work must be performed by authorized personnel only.

Installation work must be performed in accordance with the national wiring standards by authorized personnel only.

This appliance is not intended for use by persons (including children) with reduced physical, sensory or mental capabilities or lack of experience and knowledge, unless they have been given supervision or instruction concerning use of the appliance by a person responsible for their safety. Children should be supervised to ensure they are away from the appliance.

This appliance can be used by children aged from 8 years and above and persons with reduced physical, sensory or mental capabilities or lack of experience and knowledge if they have been given supervision or instruction concerning use of the appliance in a safe way and understand the hazards involved.

Children shall not play with the appliance.

Cleaning and user maintenance shall not be made by children without supervision.

Instructions for cord-connected room air conditioners shall include manufacturer's recommendations regarding the use of cord sets (extension cords). If use of an extension cord is not recommended, the instructions shall state this. Recommendations for an extension cord shall specify at least the use of a cord set with an equipment grounding conductor, grounding-type attachment plug, and grounding-type connector (load fitting) and the ampacity and voltage rating of the cord set.

## Exception Clauses

Manufacturer will bear no responsibilities when personal injury or property loss is caused by the following reasons.



1. Damage the product due to improper use or misuse of the product;
2. Alter, change, maintain or use the product with other equipment without abiding by the instruction manual of manufacturer;
3. After verification, the defect of product is directly caused by corrosive gas;
4. After verification, defects are due to improper operation during transportation of product;
5. Operate, repair, maintain the unit without abiding by instruction manual or related regulations;
6. After verification, the problem or dispute is caused by the quality specification or performance of parts and components that produced by other manufacturers;
7. The damage is caused by natural calamities, bad using environment or force majeure.

If it needs to install, move or maintain the air conditioner, please contact dealer or local service center to conduct it at first. Air conditioner must be installed, moved or maintained by appointed unit. Otherwise, it may cause serious damage or personal injury or death.



When refrigerant leaks or requires discharge during installation, maintenance, or disassembly, it should be handled by certified professionals or otherwise in compliance with local laws and regulations.

## Safety Precautions

To prevent injury to the user or other people and property damage, the following instructions must be followed. Incorrect operation due to ignoring of instructions may cause harm or damage. The seriousness is classified by the following indications.

 <b>WARNING</b>	This symbol indicates the possibility of death or serious injury.
 <b>CAUTION</b>	This symbol indicates the possibility of injury or damage to property.

- Meaning of symbols used in this manual are as shown below.

	<b>NEVER DO THIS.</b>
	<b>ALWAYS DO THIS.</b>

### WARNING

 Plug in power plug properly

- Otherwise, it may cause electric shock or fire due to excess heat generation.

 Do not operate or stop the unit by inserting or pulling out the power plug.

- It may cause electric shock or fire due to heat generation.

 Do not damage or use an unspecified power cord.

- If the power cord is damaged, it must be replaced by the manufacturer or an authorized service center in order to avoid hazard.

 Do not modify power cord length or share the outlet with other appliances.

- It may cause electric shock or fire due to heat generation.

 Do not operate with wet hands or in damp environment.

- It may cause electric shock.

 Do not direct airflow at room occupants only.

- This could damage your health.

 Always ensure effective grounding.

- Incorrect grounding may cause electric shock.

 Do not allow water to run into electric parts.

- It may cause failure of machine or electric shock.

 Always install circuit breaker and a dedicated power circuit.

- Incorrect installation may cause fire and electric shock.

 Unplug the unit if strange sounds, smell, or smoke comes from it.

- It may cause fire and electric shock.

 Do not use the socket if it is loose or damaged.

- It may cause fire and electric shock.

 Do not open the unit during operation.

- It may cause electric shock.

 Keep firearms away.

- It may cause fire.

 Do not use the power cord close to heating appliances.

- It may cause fire and electric shock.

 Do not use the power cord near flammable gas or combustibles, such as gasoline, benzene, thinner, etc.

- It may cause an explosion or fire.

 Ventilate room before operating air conditioner if there is a gas leakage from another appliance.

- It may cause explosion, fire and burns.

 Do not disassemble or modify unit.

- It may cause failure and electric shock.

## Safety Precautions

### ⚠ CAUTION

- |  |  |   |
|--|--|---|
| <p>⊘ When the air filter is to be removed, do not touch the metal parts of the unit.</p> <ul style="list-style-type: none"> <li>● It may cause an injury.</li> </ul>   | <p>⊘ Do not clean the air conditioner with water.</p> <ul style="list-style-type: none"> <li>● Water may enter the unit and degrade the insulation. It may cause an electric shock.</li> </ul>   | <p>⊘ Ventilate the room well when used together with a stove, etc.</p> <ul style="list-style-type: none"> <li>● An oxygen shortage may occur.</li> </ul>  |
| <p>⊘ When the unit is to be cleaned, switch off, and turn off the circuit breaker.</p> <ul style="list-style-type: none"> <li>● Do not clean unit when power is on as it may cause fire and electric shock, it may cause an injury.</li> </ul> | <p>⊘ Do not put a pet or house plant where it will be exposed to direct air flow.</p> <ul style="list-style-type: none"> <li>● This could injure the pet or plant.</li> </ul>  | <p>⊘ Do not use for special purposes.</p> <ul style="list-style-type: none"> <li>● Do not use this air conditioner to preserve precision devices, food, pets, plants, and art objects. It may cause deterioration of quality, etc.</li> </ul> |
| <p>⊘ Stop operation and close the window in storm or hurricane.</p> <ul style="list-style-type: none"> <li>● Operation with windows opened may cause wetting of indoor and soaking of household furniture.</li> </ul>                          | <p>⊘ Hold the plug by the head of the power plug when taking it out.</p> <ul style="list-style-type: none"> <li>● It may cause electric shock and damage.</li> </ul>   | <p>⊘ Turn off the main power switch when not using the unit for a long time.</p> <ul style="list-style-type: none"> <li>● It may cause failure of product or fire.</li> </ul>   |
| <p>⊘ Do not place obstacles around air-inlets or inside of air-outlet.</p> <ul style="list-style-type: none"> <li>● It may cause failure of appliance or accident.</li> </ul>  | <p>⊘ Ensure that the installation bracket of the outdoor appliance is not damaged due to prolonged exposure.</p> <ul style="list-style-type: none"> <li>● If bracket is damaged, there is concern of damage due to falling of unit.</li> </ul> | <p>⊘ Always insert the filters securely. Clean the filter once every two weeks.</p> <ul style="list-style-type: none"> <li>● Operation without filters may cause failure.</li> </ul>  |
| <p>⊘ Do not use strong detergent such as wax or thinner but use a soft cloth.</p> <ul style="list-style-type: none"> <li>● Appearance may be deteriorated due to change of product color or scratching of its surface.</li> </ul>              | <p>⊘ Do not place heavy object on the power cord and ensure that the power cord is not compressed.</p> <ul style="list-style-type: none"> <li>● There is danger of fire or electric shock.</li> </ul>  | <p>⊘ Do not drink water drained from air conditioner.</p> <ul style="list-style-type: none"> <li>● It contains contaminants and could make you sick.</li> </ul>   |
| <p>⊘ Use caution when unpacking and installing. Sharp edges could cause injury.</p>  | <p>⊘ If water enters the unit, turn the unit off at the power outlet and switch off the circuit breaker. Isolate supply by taking the power plug out and contact a qualified service technician.</p>   |   |

## Safety Precautions

**NOTE** The power supply cord with this air conditioner contains a current detection device designed to reduce the risk of fire. Please refer to the section Operation of Current Device, for details. In the event that the power supply cord is damaged, it cannot be repaired-it must be replaced with a cord from the Product Manufacturer.

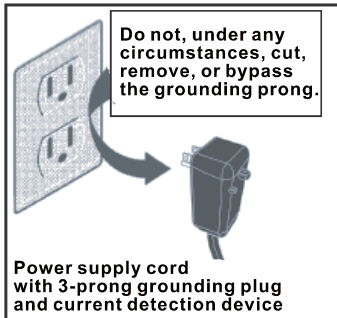

### **▲ WARNING For your safety**

- Do not store or use gasoline or other flammable vapors and liquids in the vicinity of this or any other appliance.
- Avoid fire hazard or electric shock. Do not use an extension cord or an adaptor plug. Do not remove any prong from the power cord.

### **▲ WARNING Electrical Information**

- Be sure the electrical service is adequate for the model you have chosen. This information can be found on the serial plate, which is located on the side of the cabinet and behind the grille.
  - Be sure the air conditioner is properly grounded. To minimize shock and fire hazards, proper grounding is important. The power cord is equipped with a three-prong grounding plug for protection against shock hazards.
  - Your air conditioner must be used in a properly grounded wall receptacle. If the wall receptacle you intend to use is not adequately grounded or protected by a time delay fuse or circuit breaker, have a qualified electrician install the proper receptacle.
  - Ensure the receptacle is accessible after the unit installation.
  - Do not run air conditioner without side protective cover in place. This could result in mechanical damage within the air conditioner.
- Do not use an extension cord or an adapter plug.**

## Operation of Current Device

The power supply cord contains a current device that senses damage to the power cord. To test your power supply cord do the following:

1. Plug in the Air Conditioner.
2. The power supply cord will have TWO buttons on the plug head. Press the TEST button, you will notice a click as the RESET button pops out.
3. Press the RESET button, again you will notice a click as the button engages.
4. The power supply cord is now supplying electricity to the unit. (On some products this is also indicated by a light on the plug head.)

### **NOTES:**

- Do not use this device to turn the unit on or off.
- Always make sure the RESET button is pushed in for correct operation.
- The power supply must be replaced if it fails reset when either the TEST button is pushed, or it cannot be reset. Please contact Customer Service.
- If power supply cord is damaged, it cannot be repaired. It MUST be replaced with a new cord - please contact Customer Service.

## Precautions

### Warning

- Air Conditioner should be properly grounded. Incorrect grounding may cause electric shock.
- Do not connect air conditioner to multipurpose socket. Otherwise, it may cause fire hazard.
- Do install the air switch. If not, it may cause malfunction.
- Do not spill water on the remote controller, otherwise the remote controller may be broken.
- Do not spray water on air conditioner. It may cause electric shock or malfunction.
- Do not extend fingers or objects into air inlet or air outlet. It may cause personal injury or damage.
- Do not step on air conditioner, or put heavy objects. It may cause damage or personal injury.
- Do not block air outlet or air inlet. It may cause malfunction.
- Do disconnect power supply when cleaning air conditioner. Otherwise, it may cause electric shock.
- Do not repair air conditioner by yourself. It may cause electric shock or damage. Please contact dealer when you need to repair air conditioner.
- Maintenance must be performed by qualified professionals. Otherwise, it may cause personal injury or damage.
- Please install the devices for short-circuit protection and electrical leakage protection when installing the air conditioner.

### Note:

The power cord of window type unit has creepage protection device. There're test button and reset button on the plug. You are suggested to check the power cord periodically.

### Check method:

After putting through the power, indicator is ON. After pressing test button, indicator is OFF and you can heard a sound. Then press reset button, indicator will be ON, which indicates the protection device is normal.

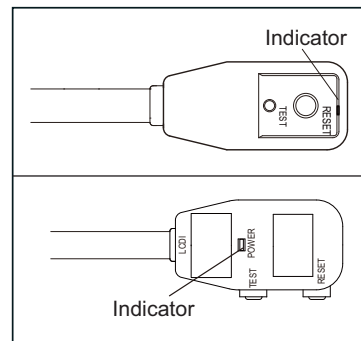

### Note:

Plug may be different with the actual product. Please refer to actual product.

## Working temperature range

	Indoor side DB/WB(°C/°F)	Outdoor side DB/WB(°C/°F)
Maximum cooling	32/23 (90/74)	43/26 (110/79)

The operating temperature range (outdoor temperature) for cooling only unit is 18°C~ 43°C (64°F~ 110°F).



## Parts Name

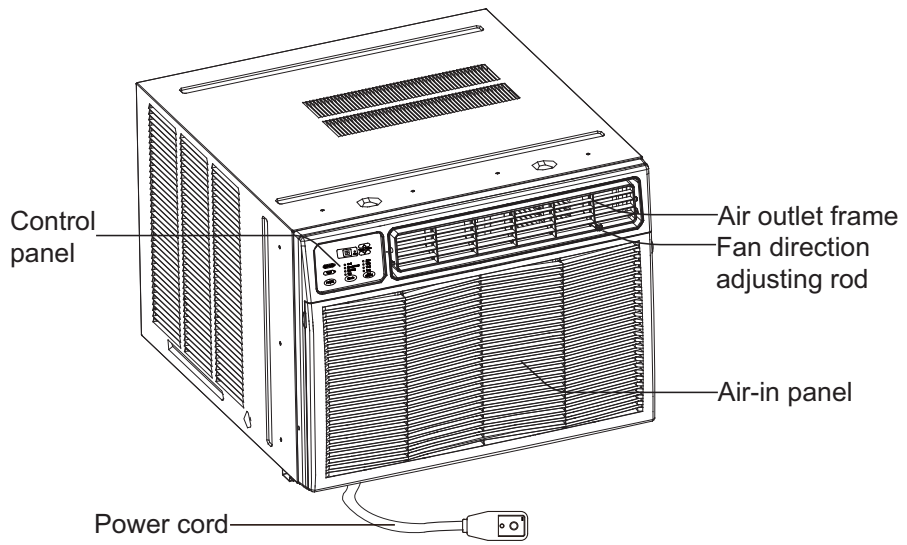

NOTE: Panel outlook picture, just for reference, please take the real unit as standard.

## Function and Control

- After putting through the power, air conditioner will give out a sound and indicators on control panel will be on. After that, you operate the air conditioner through remote controller or control panel.

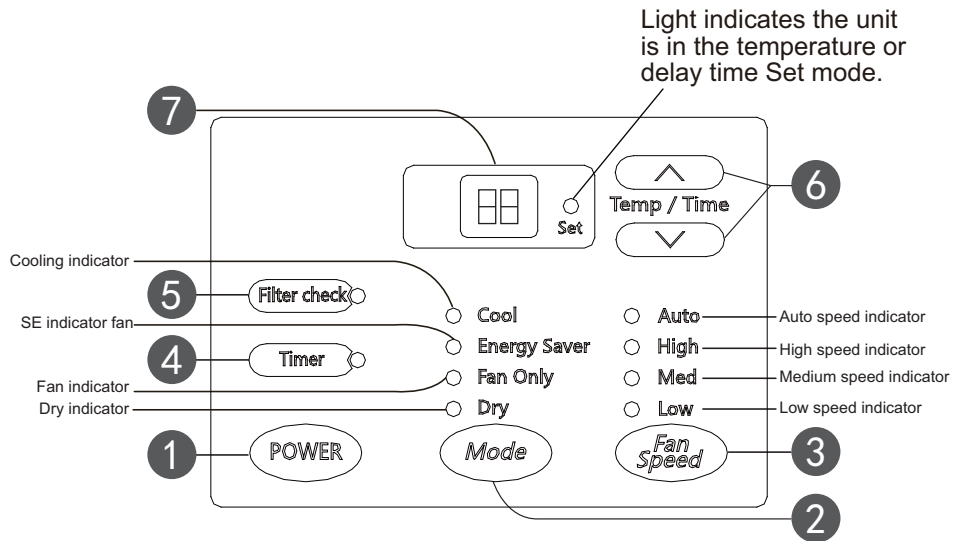

- 1 Power button
- 2 Mode button
- 3 Fan Speed button
- 4 Timer button
- 5 Filter check button
- 6 ^ / v button
- 7 Display

## 1 Power button

Press this button can turn on or turn off air conditioner.

NOTE: Press this button to turn on air conditioner, the unit will operate in Energy Save mode; if the unit is energized after power failure, the unit will still operate according to the status before power failure.

## 2 Mode button

Press this button can your required operation mode in turn. Corresponding indicator will be on.

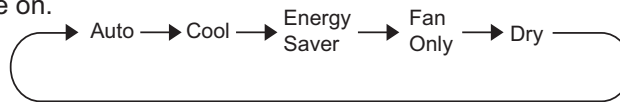

- **Auto:** Under this mode, the unit will operate automatically according to ex-factory setting. In this case, set temperature cannot be adjusted.
- **Cool:** Under this mode, air conditioner operates under cooling mode. Cooling indicator will be on. Press “Fan Speed” button can adjust the fan speed.
- **Energy Save:** Under this mode, air conditioner operates under SE mode. SE indicator will be on. Press “Fan Speed” button can adjust the fan speed.
- **Fan Only:** Under this mode, air conditioner will not cool or heat, only blow wind. Fan indicator will be on. Press “Fan Speed” button can adjust the fan speed. (No auto fan speed under fan mode)
- **Dry:** Under this mode, the unit runs in low fan speed for dehumidification and the corresponding indicator is on; under dry mode, the fan speed cannot be adjusted.

## 3 Fan Speed button

Press this button can select your required fan speed in turn. Corresponding speed indicator will be on.

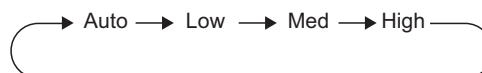

## 4 Timer button

**Timer ON:** Can be set under off state of unit. If timer ON reaches, the system will run under Energy Save mode. The setting range is 0.5~24hr.

**Timer OFF:** Can be set under on state of unit. If timer OFF reaches, the unit will turn off. The timer can be set in 0.5 hour increment below 10 hours and in 1 hour increment for 10 hours or above.

### 5 Filter check button

After fan rotates for 250h totally, lamp of cleaning filter is on to remind customer clean it.

**Note:** When user cleaned the filter, press Filter check button to clear the operation time. Meanwhile, the warning indicator will turn off.

### 6 ^ / v button

Under temperature setting status, after each pressing of “^” or “v” button, temperature will increase or decrease 1°F. Temperature setting range: 64~86°F. Under timer setting status, after each pressing of “^” or “v” button, time will increase or decrease 0.5h or 1h.

### 7 Display

1. Under ON status without timer setting, the operation mode is Auto, Cool, Energy Saver or Dry mode, and the set temperature will be displayed.
2. Under ON status without timer setting, the operation mode is fan mode and the ambient temperature will be displayed.
3. Time will be displayed under timer setting or timer preview.

## Introduction of remote controller

### Note:

This is a general use remote controller, it could be used for the air conditioners with multifunction; For some function, which the model doesn't have, if press the corresponding button on the remote controller that the unit will keep the original running status.

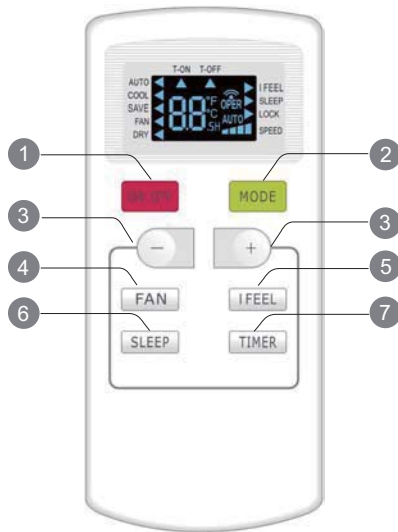

- ① ON/OFF button
- ② MODE button
- ③ + / - button
- ④ FAN button
- ⑤ I FEEL button
- ⑥ SLEEP button
- ⑦ TIMER button

### ① ON/OFF button

Press this button to turn on the unit, turning on the unit with remote controller, the unit will operate in energy-saving mode. Press this button again to turn off the unit. NOTE: If energize the unit and turn it on, or turn it off and then turn it on, the unit will operate in energy-saving mode; if the unit is energized after power failure, the unit will still operate according to the status before power failure.

### ② MODE button

Each time you press the button, a mode is selected in a sequence that goes from AUTO, COOL, SAVE, FAN and DRY, as the following:

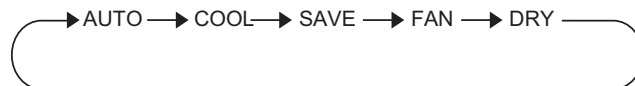

### 3 - / + button

- Pressing + or - button once will increase or decrease set temperature by 1°F(°C). Hold + or - button for 2s, set temperature on remote controller will change quickly. Release the button after your required set temperature is reached.
- Under timer setting status, after each pressing of “+” or “-” button, time will increase or decrease 0.5h . Hold “+” or “-” button, 2s later, time displayed on dual-8 nixie tube will change quickly. Loosen the button until the time is reached to your set time.

### 4 FAN button

This button is used for setting Fan Speed in the sequence that goes from AUTO,

▲, ▲▲, ▲▲▲, to ▲▲▲▲ then back to Auto.

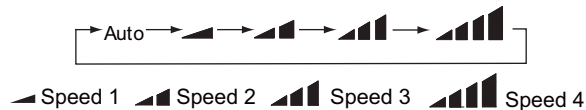

NOTE: There are 3 speeds for the Fan Speed of this model.

### 5 I FEEL button

I feel function will be action if pressing this button. If controller receives I FEEL order, it will work under ambient temperature value which sending by remote controller, and remote controller will send ambient temperature value to controller every 10min. After 11min, if controller does not receive ambient temperature value which sending by remote controller, it will run with AC ambient temperature; if I FEEL is not set, ambient temperature will adopt sampling value of AC temperature sensor. If power off happens, this function will not be memorized.

### 6 SLEEP button

Press this button to go into the SLEEP operation mode. Press it again to cancel this function. This function is available in COOL, HEAT (Only for models with heating function) or DRY mode to maintain the most comfortable temperature for you.

### 7 TIMER button

Press this button to initiate auto-on/auto-off timer. To cancel auto-timer program, press this button twice.

## Replacement of Batteries in Remote Controller

1. Press the mark “” on back cover of batteries box cover for remote controller with fingers as shown in the fig, and then remove the batteries box cover along the arrow direction.
2. Replace with two #7 (AAA 1.5V) dry batteries. Make sure positions for “+” pole and “-” pole are correct.
3. Reinstall batteries box cover.

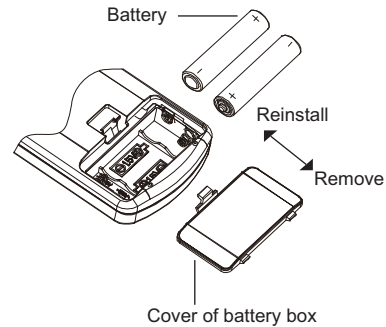

### **NOTICE**

- The distance between signal sender and receiving window should be no more than 8m, and there should be no obstacles between them.
- As the signal will be interfered in the room with electronic fluorescent lamp, conversion fluorescent lamp or wireless phone, please get closer to the air conditioner when using the remote controller.
- Replace new batteries of the same model when replacement is required.
- When you don't use remote controller for a long time, please take out the batteries.

## Instruction for fan direction adjusting

- You can adjust the fan direction adjusting rod to select left&right air outlet direction according to your requirement.

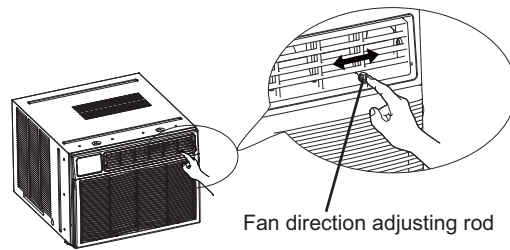

- You can adjust the air outlet frame to select up&down air outlet direction according to your requirement.

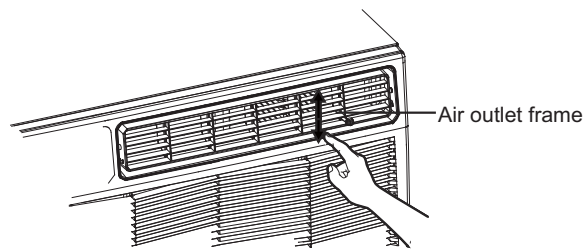



## Clean and Maintenance

### Warning

- Turn off the air conditioner and disconnect the power before cleaning the air conditioner to avoid electric shock.
- Do not wash the air conditioner with water to avoid electric shock.
- Do not use volatile liquid to clean the air conditioner.

### Clean filter

#### 1. Open the panel

Pull the groove at both sides of panel forcibly to open the panel to a certain angle as shown in the fig.

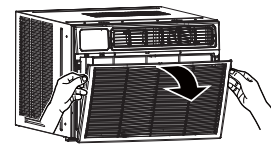

#### 2. Remove the filter

Remove the filter as shown in the fig.

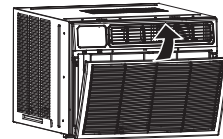

#### 3. Clean the filter

- Use dust catcher or water to clean the filter.
- If the filter is very dirty, you can use the warm water (below 45 degree) dissolved with neutral abluent, and then put it under the shady place.

#### 4. Install filter

Install the filter and then buckle the panel cover tightly.

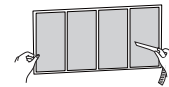

### Note:

- Clean the filter about once every three month. If there are lots of dust in operation environment , you can increase the clean times.
- Due to there's shaft metal fins in the air conditioner, do no touch the fins after removing filter to avoid scratching.
- Do not dry the filter on fire or use hair drier to dry the filter. Otherwise, the filter may be deformed or catch fire.
- Do not operate the air conditioner when the filter hasn't been installed.

### Clean the panel

If the surface of panel is very dirty, you are suggested to use soft dry cloth or wet cloth dipped with neutral abluent to wipe it.

**Note:** Do not remove the panel when cleaning it.

### Maintain the outer case

You are suggested to check the outer case of air conditioner one or twice every year. If the outer case is damaged or rusted, please contact dealer.

**Note:** In order to reduce damage or rust under no-use season, you can cover the air conditioner with protective covering.

## Malfunction analysis

### General phenomenon analysis

Please check below items before asking for maintenance. If the problem still can't be solved, please contact dealer or professional person.

Phenomenon	Troubleshooting	Solution
Air conditioner can't operate	• Power failure?	• Wait after power recovery.
	• Is plug loose?	• Reinsert the plug.
	• Whether the air switch is tripped off or fuse is burnt?	• Ask professional person to replace air switch or fuse.
	• Is there's malfunction for the circuit?	• Ask professional person to replace circuit.
	• Whether the unit is restarted up after stopping immediately?	• Wait after voltage is resumed.
	• The protection device for the plug of power cord tripps off?	• Please press reset button on plug again. If the power tripps off again and heard a sound, there's malfunction for the plug or the unit. Please contact after-sales maintenance person.
Poor cooling (heating)	• Is the power too low?	• Wait after voltage is resumed.
	• Whether the air filter is too dirty?	• Clean the air filter.
	• Whether the set temperature is proper?	• Adjust the temperature.
	• Whether door and window are closed?	• Close door and window.
Air conditioner can't receive signal from remote controller or remote controller is not sensible.	• Whether the unit is interfered seriously (such as static pressure, unstable voltage)?	• Please pull out the plug. Insert the plug after about 3min, and then turn on the unit.
	• Whether remote controller is within the receiving range?	• The receiving range of remote controller is 8m. Do not exceed this range.
	• Whether it's blocked by obstacles?	• Remove the obstacles.
	• Is sensitivity of remote controller low?	• Check the batteries of remote controller. If the power is low, please replace the batteries.
	• Whether there's fluorescence lamp in the room?	• Move the remote controller close to air conditioner. • Turn off the fluorescence lamp and try it again.

No fan blown out from air conditioner	• Whether air outlet or air inlet is blocked?	• Eliminate the obstacles.
	• Under heating mode, whether indoor temperature is reached to set temperature?	• Indoor unit will stop blowing fan after reaching to set temperature.
	• Whether heating mode is started up just now?	• In order to prevent cold air, air conditioner will delay for a while to be started up, which is the normal phenomenon.
Set temperature can't be adjusted	• Whether the unit operates under auto mode or fan mode?	• Temperature can't be adjusted under auto mode or fan mode.
	• Whether the required temperature exceeds the temperature setting range?	• Temperature setting range: 61°F -86°F.
There's off flavour	• There's off-flavour source in the room, such as furniture, cigarette etc.	• Eliminate the off-flavor source.
		• Clean the filter.
There's abnormal sound during operation	• Whether the unit is interfered by thunder, radio, etc?	• Disconnect power, put through the power again, and then turn on the unit again.
You can heard water-flowing sound	• Whether the unit is turned on or turned off just now?	• There's flowing sound of refrigerant inside the air conditioner, which is the normal phenomenon.
You can heard the sound of "PAPA"	• Whether the unit is turned on or turned off just now?	• Heat expansion or shrinkage for the panel due to change of temperature, which cause friction sound.

### Malfunction code

When there's abnormal phenomenon for the air conditioner, dual-8 nixie tube displays corresponding malfunction code:

Malfunction code	Solution
F1	Please contact professional person to deal with it.
F2	Please contact professional person to deal with it.
F4	Please contact professional person to deal with it.
FJ	Please contact professional person to deal with it.
EP	Please contact professional person to deal with it.
H3	Please contact professional person to deal with it.
F0	Please contact professional person to deal with it.
E8	high temperature protection of condenser

### Warning

- If there's below phenomenon, please turn off the air conditioner and disconnect the power immediately. After that, please contact dealer at once.
  - Power cord is overheating or damaged.
  - There's abnormal sound during operation.
  - There's burning smell.
  - Power cord test or reset button often bounces automatically.
  - Water leakage at indoor side.
- Do not repair or refit the air conditioner by yourself.
- Operate the air conditioner under abnormal status will cause malfunction, electric shock or fire hazard.

## Installation and Maintenance

### Warning

- Observe all governing codes and ordinances.
- Do not use damaged or non-standard power cord.
- Be caution during installation and maintenance. Prohibit incorrect operation to prevent electric shock, casualty and other accidents.

### Selection of Installation Location

#### Basic requirement

Installing the unit in the following places may cause malfunction. If it is unavoidable, please consult the local dealer:

1. The place with strong heat sources, vapors, flammable or explosive gas, or volatile objects spread in the air.
2. The place with high-frequency devices (such as welding machine, medical equipment).
3. The place near coast area.
4. The place with oil or fumes in the air.
5. The place with sulfureted gas.
6. Other places with special circumstances.

#### Requirement of complete unit











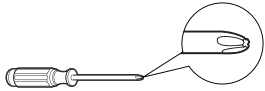



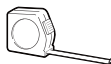
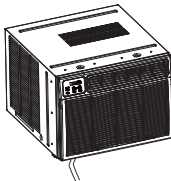
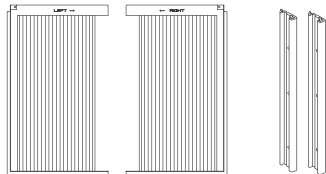

1. There should be no obstruction near air inlet and air outlet.
2. Select a location where the condensation water can be dispersed easily and won't affect other people.
3. The location should be able to withstand the weight of indoor unit and won't increase noise and vibration.
4. Select a location where the noise and outflow air emitted by the outdoor unit will not affect neighborhood.
5. The location should be able to withstand the weight of unit.
6. Select a location which is out of reach for children and far away from animals or plants. If it is unavoidable, please add fence for safety purpose.
7. Please try your best to keep far away from fluorescent lamp.

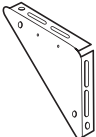
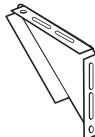
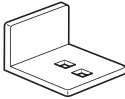
## Requirements for Electric Connection

### Safety precaution

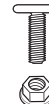
1. Must follow the electric safety regulations when installing the unit.
2. According to the local safety regulations, use qualified power supply circuit and air switch.
3. Make sure the power supply matches with the requirement of air conditioner. Unstable power supply or incorrect wiring may result in electric shock, fire hazard or malfunction.
4. Please make sure the power supply complies with the requirement of air conditioner. Unstable power supply or wrong wiring may lead to electric shock, fire hazard or malfunction.
5. Properly connect the live wire, neutral wire and grounding wire of power socket.
6. Be sure to cut off the power supply before proceeding any work related to electricity and safety.
7. Do not put through the power before finishing installation.
8. The air conditioner is first class electric appliance. It must be properly grounding with specialized grounding device by a professional. Please make sure it is always grounded effectively, otherwise it may cause electric shock.
9. The yellow-green wire or green wire in air conditioner is grounding wire, which can't be used for other purposes.
10. The grounding resistance should comply with national electric safety regulations.

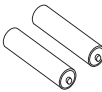
## Preparation before installation

<b>Tools for installation</b>					
	Phillips screwdriver		Screwdriver		
					
	Level bar	Scissors	Pencil	Measuring tape	
<b>Products and spare parts list</b>					
	Window type unit		Flexible screen and strip of flexible screen		
					
	Sealing strip ( without adhesive)		Upper guide rail		
					
	Sealing strip ( with adhesive)		Sponge		
					
	Left tripod (1)	Right tripod (1)	Supporter (2)	Fixing bracket for window (2)	
					
	Type A screw (10)	Type C screw (4)	Type E screw (4)	Type F screw (2)	
					
Remote controller	Batteries		Owner's manual		

## Window types and requirements

### Note:

- The description for below installation is for the standard window. If it's other types of window, you may need to adjust the window.
- If you need to install the air conditioner at the small window, you may not need to use the flexible screen sub-assy. Please refer to requirement of window size for details.
- All parts used for supporting air conditioner should be fixed at solid wooden strap, brick or metal.
- Socket must be installed at the position where the power cord is available.

### Standard window

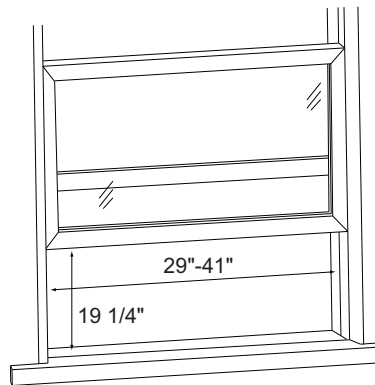

### Weather-proof type window

The height of window frame is higher than windowsill for some weather-proof type window, which will affect the installation of air conditioner. In this case, before installing the air conditioner, add wooden strap on the windowsill, and fix the wooden strap at the windowsill.

#### Specification of wooden strap:

Width: about 2"

Length: same to the inner frame size of window

Height: Put the wooden strap on the windowsill, top part of wooden strap and window frame should be at the same horizontal level, or higher than the top part of window frame for about 1/2"

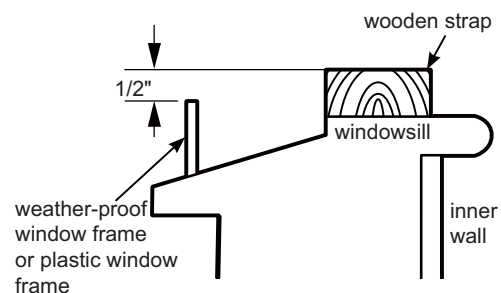



## Installation procedure

### Step 1: Remove outer case

1. Hold the clasps at the two sides of panel; pull out the panel to a certain degree along the arrow direction and then lift the panel upwards to remove it. Take out the filter after the panel is removed.

**Note:** For some types of panel, pull out the bottom to a certain degree and then lift the panel upwards to remove it.

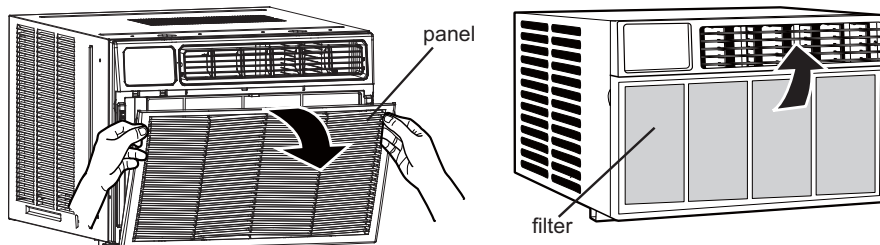

2. Remove the four screws fixing front case and then remove the front case.

**Note:** When removing the front case, pull out the bottom and then lift the front case upwards to remove it.

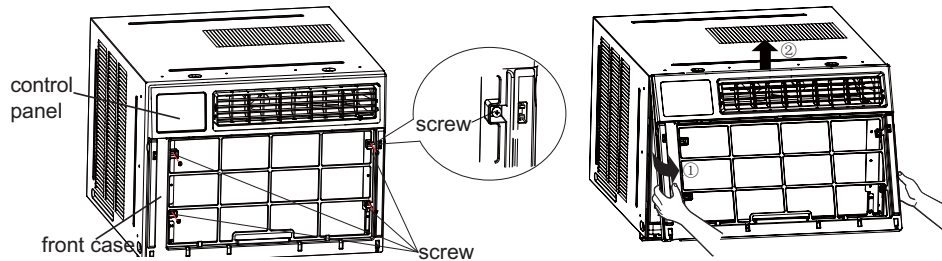

3. Remove the screws fixing control cover.

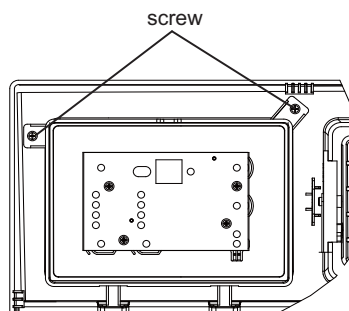

- Remove the two fixing screws at the top of outer case and the grounding screw at the two sides of outer case, and then pull out the main unit from the outer case. (It is advised that two persons handle this operation, one person holding the outer case and the other person holding the clasp of main unit and pulling out the main unit from outer case.)

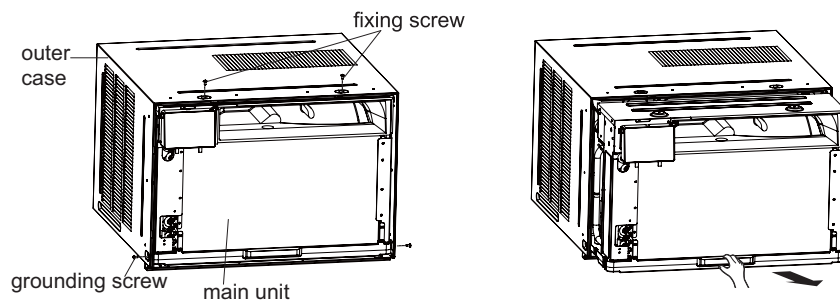

- Tear off the binder fixing gasket and then take out the gasket and binder.

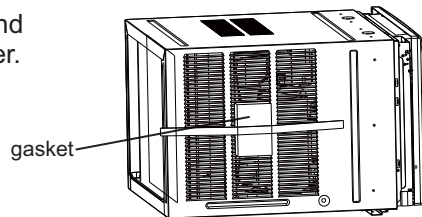

## Step 2: Install upper guide rail

- Tear off the paster at the back of sealing strip, and then align it at the bottom edge of upper guide rail to stick the sealing strip at the bottom of upper guide rail.
- Use four type A screws to fix the upper guide rail at the outer case.

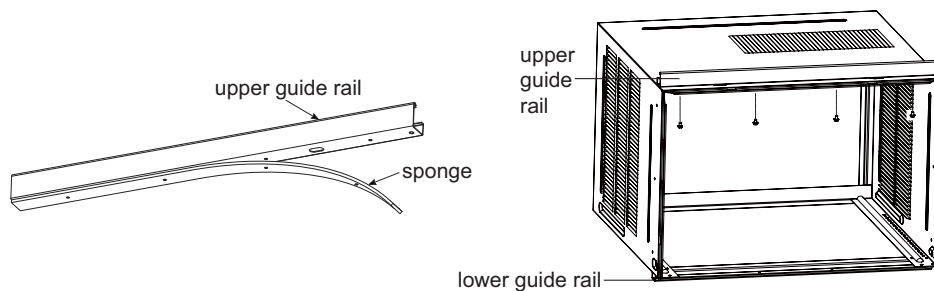

### Step 3: Install flexible screen

1. Slide the upper and lower ends of flexible screen into upper and lower guide rails.

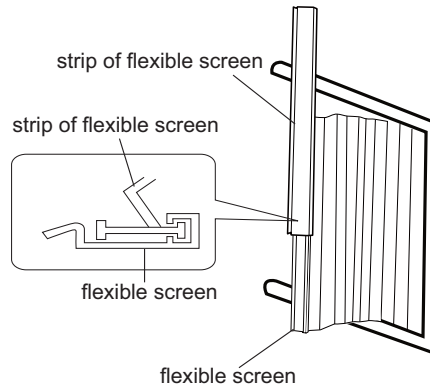

2. Slide the upper and lower ends of flexible screen into the guide rails.

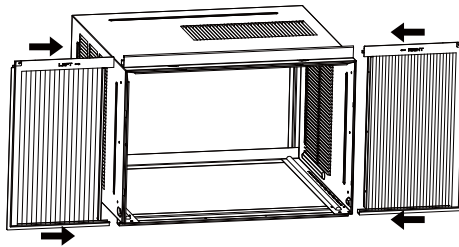

3. Fix the flexible screen at the outer case with six type A screws. (The screw fixing way is different for different models, please refer to the actual situation.)

A: Tighten screws from inside to outside of outer case.

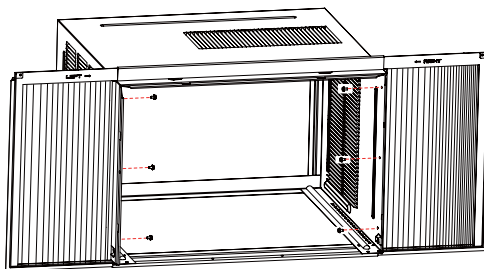

B: Tighten screws from outside to inside of outer case.

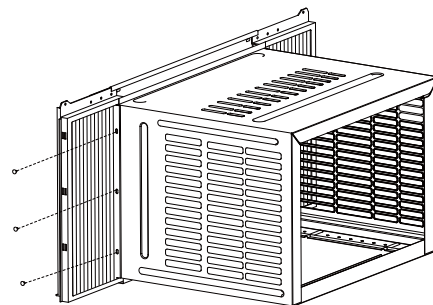

#### Step 4: Stick sealing strip

Stick the sealing strip (with adhesive) at the bottom of window frame.

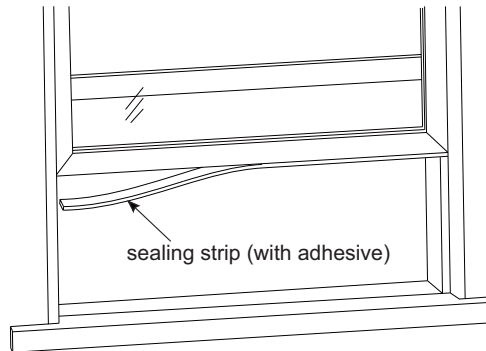

#### Step 5: Install outer case

1. Put the outer case at the windowsill, and the lower guide rail should be stuck to the windowsill. The outer case stays at the middle; the upper guide rail stays at the middle lower part of window; the window can stick to the upper guide rail when closing it and then fix the outer case with two type C screws.

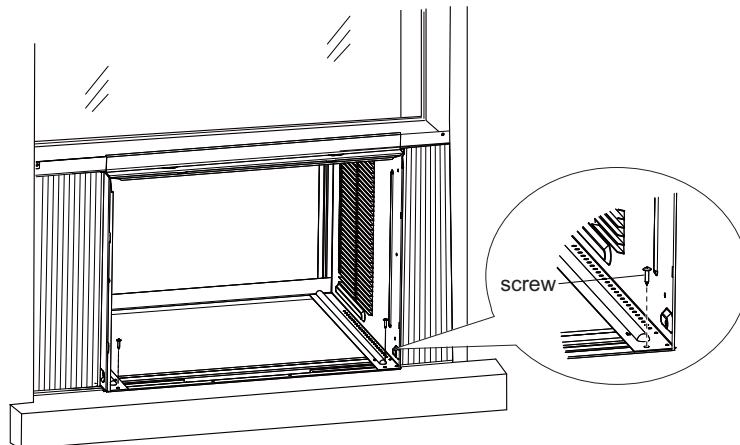

2. Install the supporter to the tripod with screw; clamp the supporter at the window sill to make the tripod support the outer case, and then fix the tripod and outdoor unit with screw.

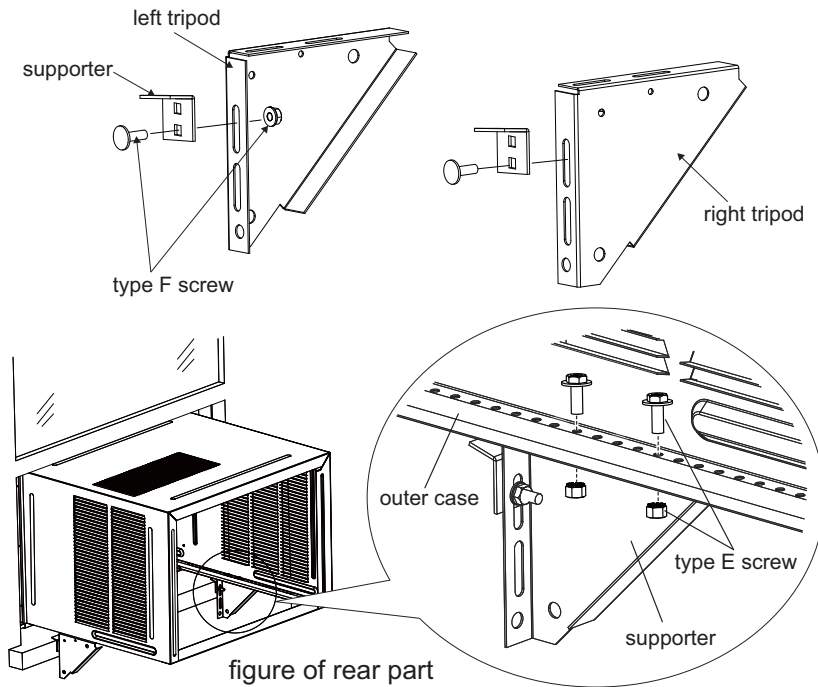

3. Adjust the position of screw connecting the tripod and supporter into order to adjust the gradient of outer case. Tighten the screw after finishing adjusting. (Note: The outer case should be placed horizontally or inclined outwards slightly.)

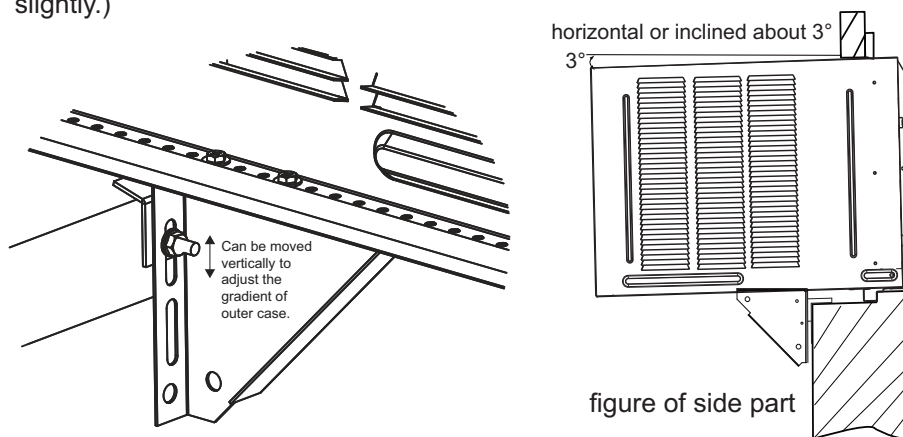

4. Fix the flexible screen with two type C screws.

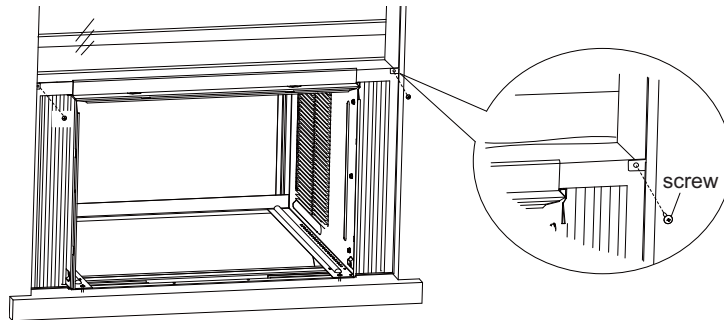

### Step 6: Install fixing bracket of window

Fix the window with the fixing bracket of window.

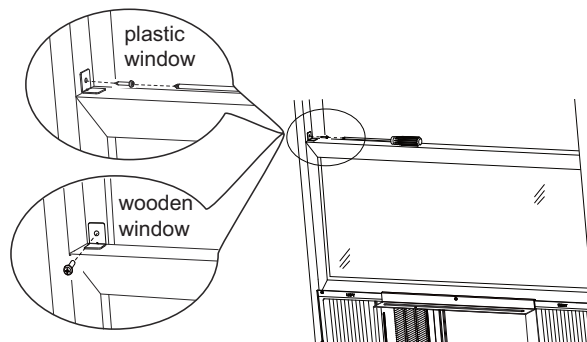

### Step 7: Plug sealing strip

Plug the sealing strip (without adhesive) in the window.

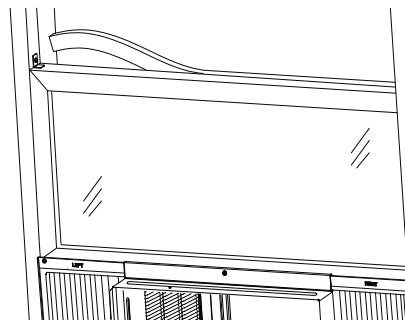

### Step 8: Install main unit

1. Ask two persons to push the main unit slowly into the outer case.

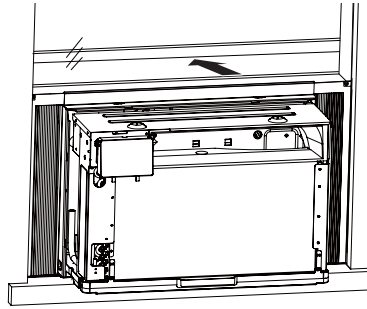

2. Install the grounding screw at the two sides and fix the control cover with screw.

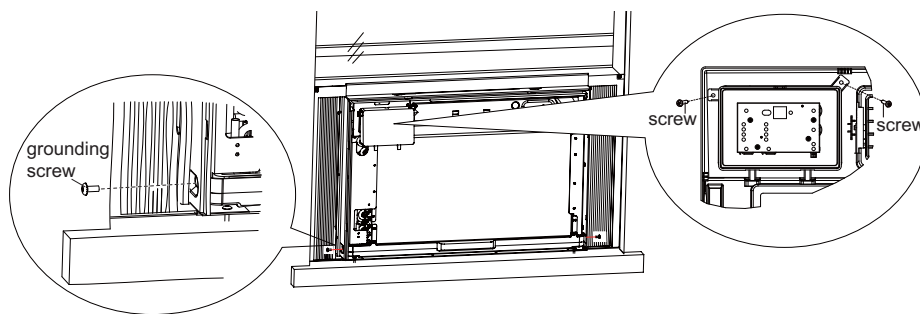

4. Install the front case and then fix it with screw. (fasten the upper part of front case at the top of outer case, and then push the bottom of front case)

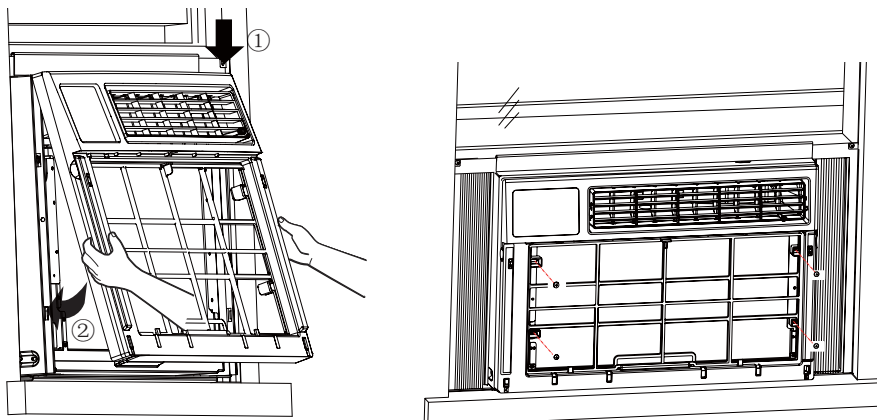

5. Assemble the filter and panel.

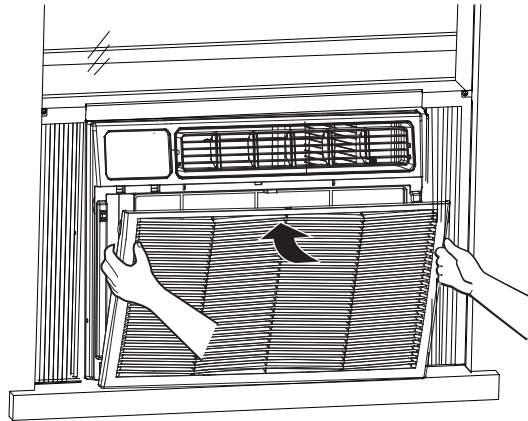



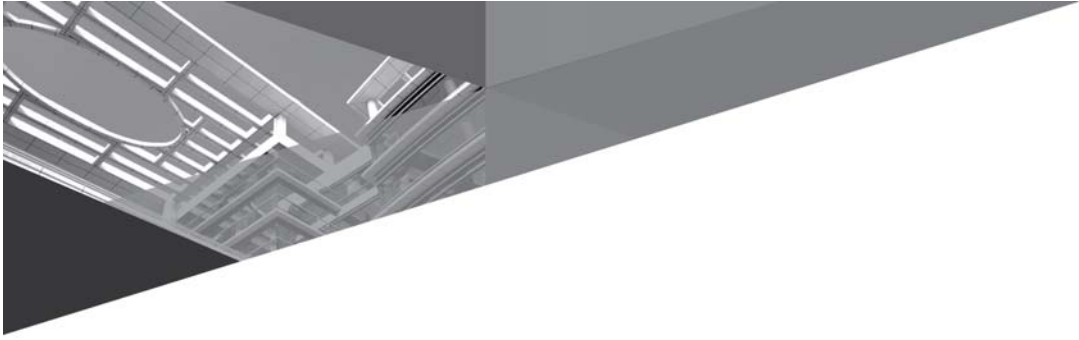

**GREE ELECTRIC APPLIANCES, INC. OF ZHUHAI**

Add: West Jinji Rd, Qianshan, Zhuhai, Guangdong, China, 519070

Tel: (+86-756) 8522218

Fax: (+86-756) 8669426

E-mail: [global@cn.gree.com](mailto:global@cn.gree.com)

Web: [www.gree.com](http://www.gree.com)



600005062475