



BRIDE
USA



**Please do not return this product to the retailer!!!
If you find that you have any trouble with assembly or
missing or damaged parts, please contact us at:**

Toll-Free - 1-800-671-9786

Ph- 469-209-8741

Or via EMAIL at:

techsupport@bestrideoncars.com



1, Cautions-----	2
2, Vehicle structure-----	3
3, Bike Assembling-----	4 - 5
4, How to use-----	6 -11
5, Daily maintenance-----	12 -16

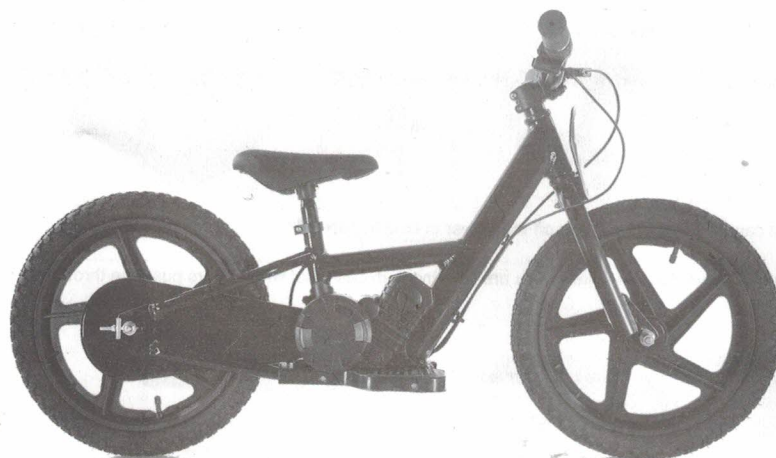

1. Note: the product pictures are for illustration purpose only. These pictures may not reflect the exact out looking of actual product. Specifications may change. Before using the bike, please must read the manual carefully and inspect whether the parts are in good conditions, to ensure children and riding safely. If there is any problem, please contact the dealer immediately.
 2. Children are required to use the bike under the supervision of parents or adults.
 3. The bike should be parked in a dry and ventilated place. Do not rinse the bike with water. It is recommended to wipe it with a cloth.
 4. Please comply with local laws or regulations; Please slow down and increase the braking distance in rainy/snowy day or slippery road, to sure the safety.
 5. Non-professional maintenance persons are prohibited from disassembling and replacing parts.
 6. The bike is forbidden to do stunt riding.
 7. Please inspect and sure all screws are tight before riding.
 8. When the bike is with electricity but cannot drive, please turn off the power in time in case of electric components damage.
 9. Please turn off the power when you get down from the bike or you are pushing it, in case that when riders push the throttle unintentionally , the bike starts suddenly and get hurt.
 10. Never operate the bike if side cover and chain cover are not installed.
- Do not allow hands, feet, body, clothing or other similar items to come into contact with any rotating or moving parts.
11. Pls charge the bike by the specialized charger, if use other charger will damage the battery.

- 1. Front wheel
- 2. Tire
- 3. Front fork
- 4. Stem
- 5. Frame
- 6. Saddle
- 7. Seat post
- 8. Inner tube
- 9. Rear wheel
- 10. Chain adjuster
- 11. Chain cover
- 12. Side cover
- 13. Controller
- 14. Battery
- 15. Seat post release

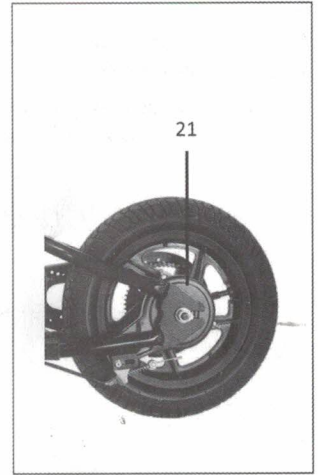
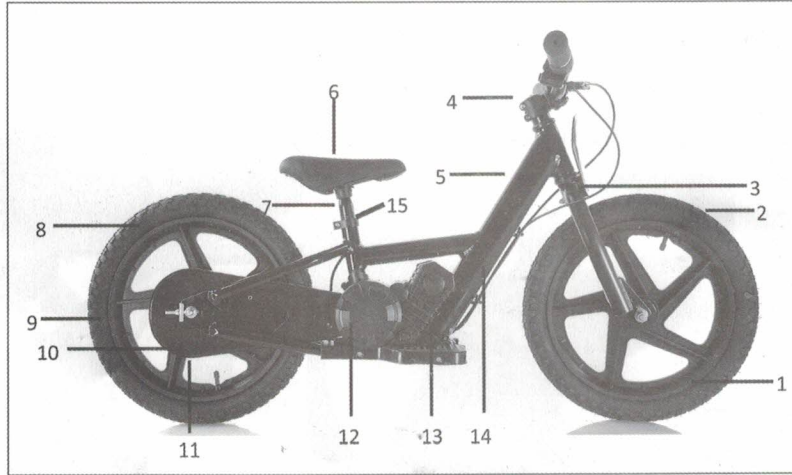

- 16. Throttle
- 17. Handlebar
- 18. Left brake lever
- 19. Left grip
- 20. Braking cable
- 21. Rear drum brake

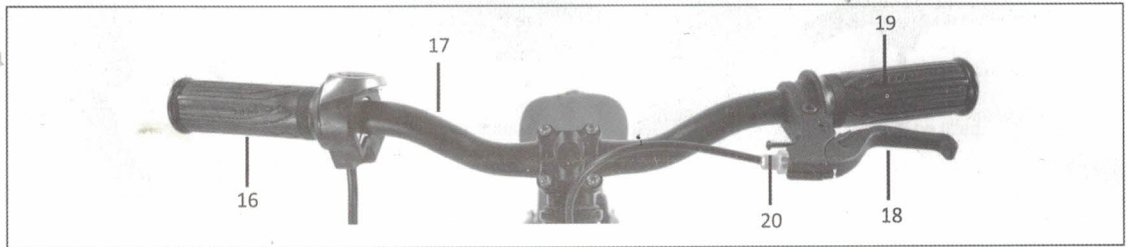

Sedna 12

1. Please take out the bike from carton, remove the packing and fix the handlebar on the stem tightly with a hex wrench.

2. installation requirements:

- 2.1 Handlebar needs to be symmetrical
- 2.2 Correct the horizontal angle, the brake level is about 45° horizontally

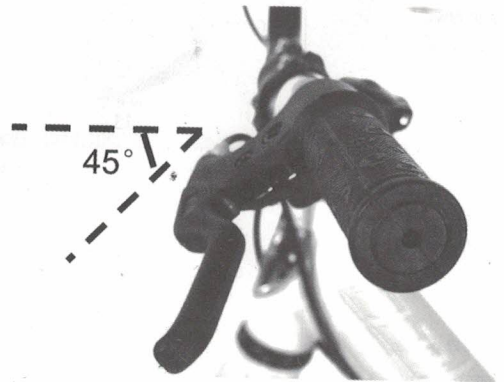
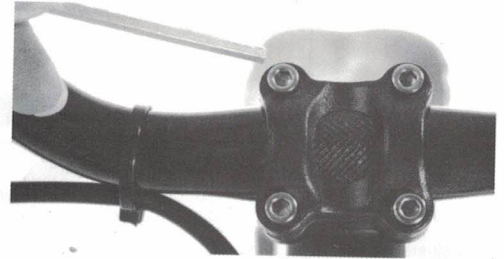
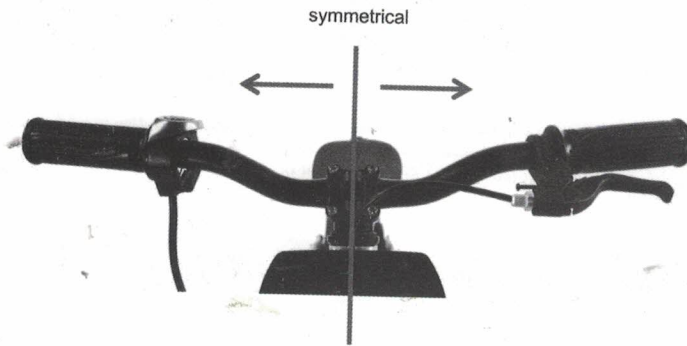

Sedna 16

1. Take the bike out of the carton and remove the extra package, then fix the front wheel with the front fork by 13-15 spanner.

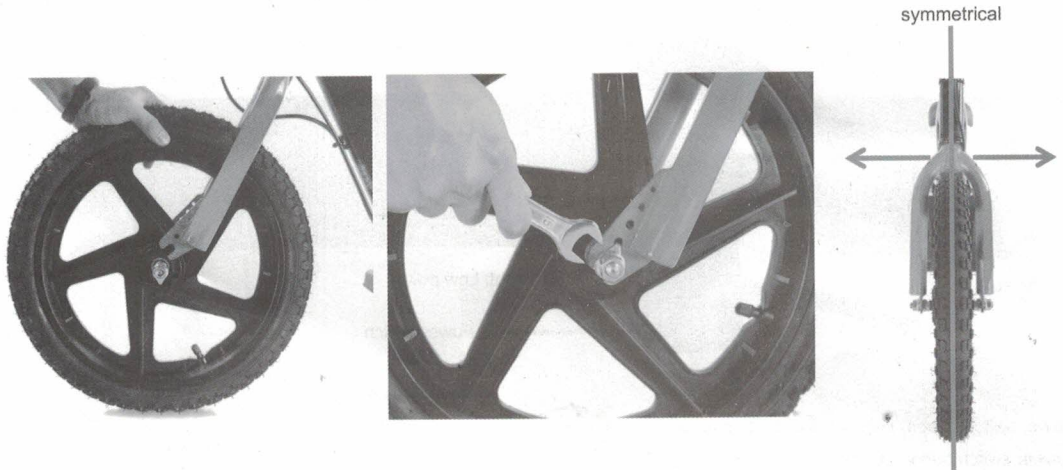

Attention:

1.1 When the front wheel is fixed by spanner, pay attention to the gap on two sides of the wheel should be symmetrical, it must not be tilted.

How To Use

1. Please wear personal protective equipment, like helmet, protective glass, sneaker, glove, elbow pad, knee pad etc.
2. Throttle/Display instruction

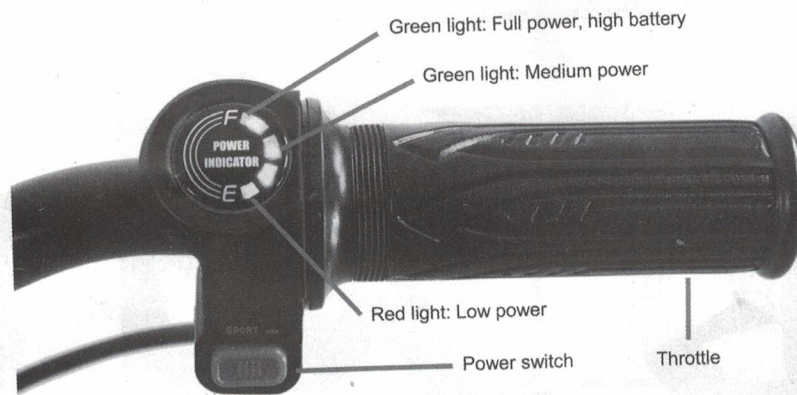

- 2.2. Press power switch button, battery indicator light is on;
Press power switch button, battery indicator light is off;
- 2.3. Use the hand to turn the throttle to control the power
3. In order to protect the safety of children, after the power switch is turned on, the display shows that the power is on, and the switch has a 5-second slow start function.

4. Replace and disassemble the battery:

4.1 Turn off the power firstly. Then slide the bike on the ground gently. Open the rubber dust-proof cover of battery and open the lock by key as the indicating direction of arrow.

4.2 Hold the both side of battery and pull it out from the frame.

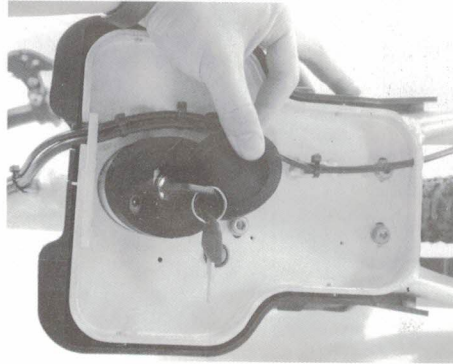

4.1

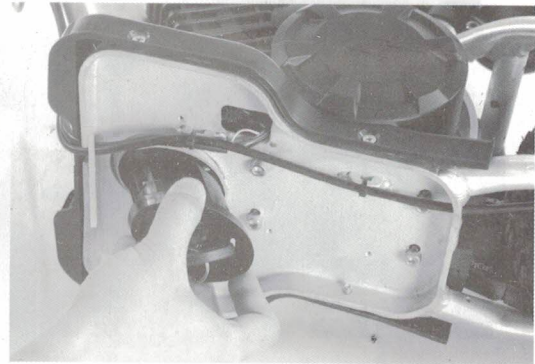

4.2

4.3 Push the battery into the frame along the track, pay attention to the direction of battery.

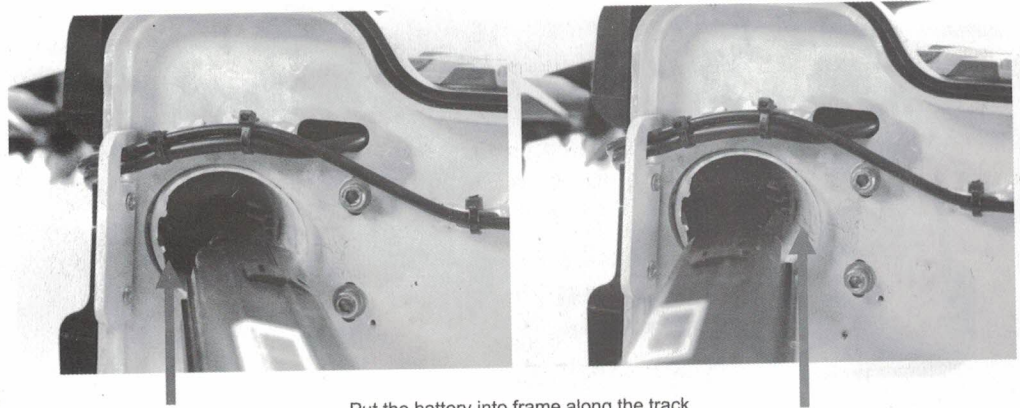

Put the battery into frame along the track

4.4 Lock the battery by key and close the rubber dust-proof cover of battery.

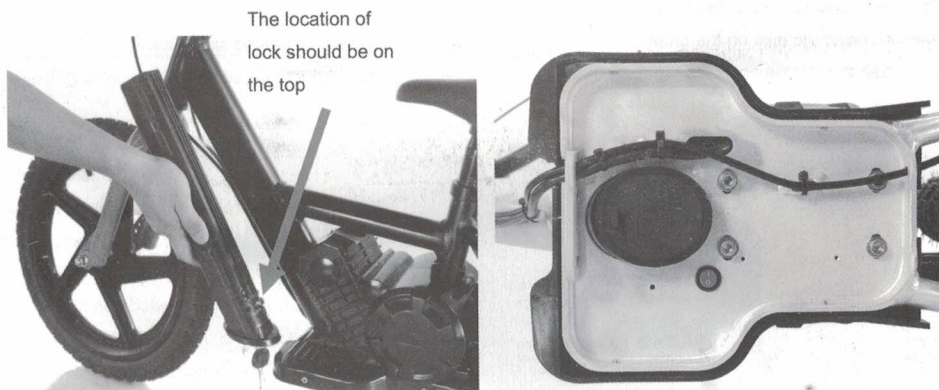

How To Use

5. Speed conversion instructions :

In order to protect children and prevent riding speed from being too fast, the figure below shows the controller plug-in connection speed limit line. The plug-in speed limit line is disconnected and turned on to realize two speed modes:

Mode 1: The speed limit line is disconnected, the bike speed has no speed limit(the speed of sedna12 is 13KM/H,the speed of sedna16 is 18KM/H).

Mode 2: The speed limit line is connected, the bike speed is the default factory settings. the speed of sedna12 is 6KM/H,the speed of sedna16 is 9KM/H).

The operation of this speed change switch requires an adult to operate.

5.1 Turn off the power and lean the bike on the ground. Turn off the speed limit switch. The bike has no speed limit.

5.2 Turn on the power ,turn the throttle and race the rear wheel,check whether the speed have changed.

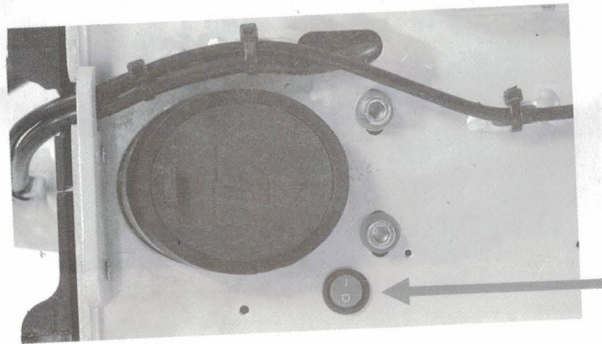

How To Use

6. Start-up process: sit, push, push the throttle, brake, practice (Please wear personal protective equipment in the open air or safe place under the supervision of an adult)

Unpowered training:

- 6.1. Turn off the power.
- 6.2. Adjust the seat cushion position according to the height of the rider.
- 6.3. Use your feet on the ground to promote learning and balance.
- 6.4. Practice gliding and practice to control the turn.
- 6.5. Use the brakes to safely stop while maintaining balance.

Electric mode:

- 6.6. Turn on the power switch.
 - 6.7. Turn the display to normal.
 - 6.8. Place your feet on the ground, let the rider slowly move forward and practice twisting the handle and slowly accelerate.
 - 6.9. Let the rider practice opening and closing the switch and safely control the brake to stop.
 - 6.10. When the rider is skillful in controlling the throttle and brake skills, place your feet on the pedals.
 - 6.11. Please keep a safe distance between the rider and the obstacles. Pay attention to avoiding pedestrians and pay attention to controlling the speed.
 - 6.12. Pay attention to the car and then turn off the power before you can get off.
7. The bike can increase the auxiliary wheel to speed up children to learn riding

Daily Maintenance

1. Chain loosening: adjust the jack screw to adjust the chain

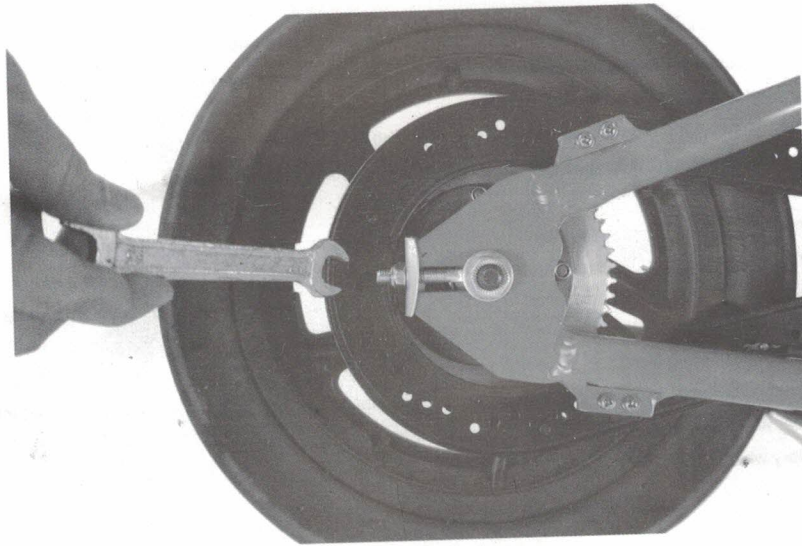

2. After riding the bike for a period of time, if there is a wheel lock or wobble, please fine-tune the wheel lock nut

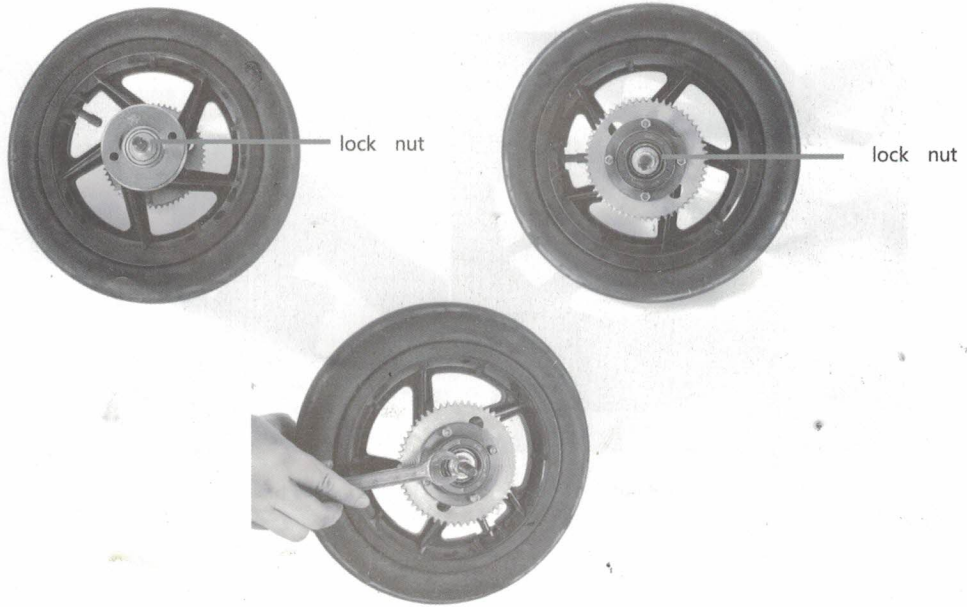

Daily Maintenance

3. Braking performance adjustment: please fine-tune the brake nut
Or fine-tune the braking nut on braking lever.

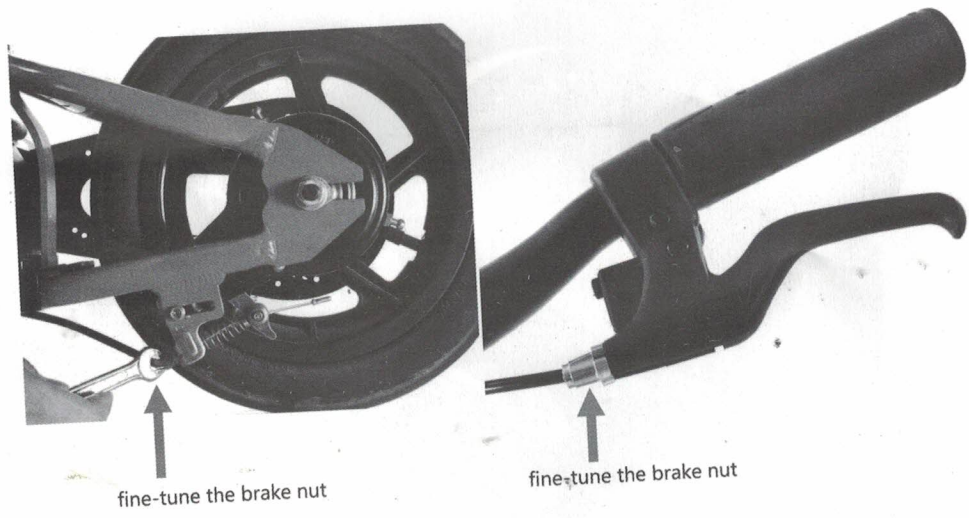

4. Charging battery: please open the waterproof cover of charging port, plug the charger DC head into charging port and fit the plug to the power supply.(red light means the bike is charging, the green light means the battery is full.)

5. Adjusting the saddle height: The seat post is prohibited from exceeding the security line.

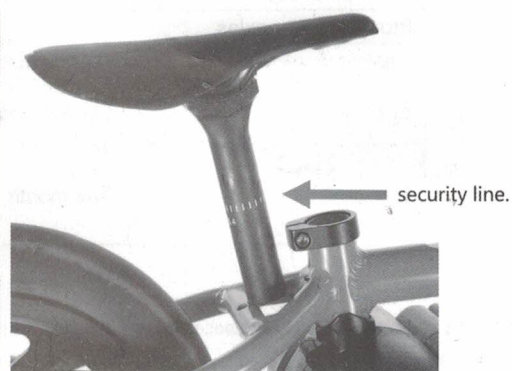
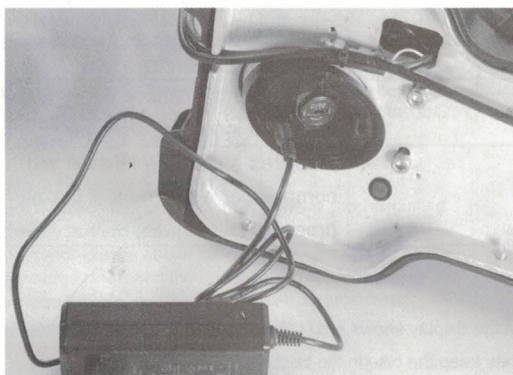

1. Lubrication is an important part of the maintenance of electric balance bicycle. The front axle, rear axle, and sprocket should be scrubbed every six months.

Maintenance Item	Maintenance cycle	Tools and Remark
Head parts set	One year	Grease
Front and rear axles	One year	Grease
Chain	Six months	Lubricating oil
Battery	Two months	Recharge the battery every two months if long time storage
Tyre pressure	One month	The tires should be inflated with compressor equipment if the air pressure is low

2. Do not drain the battery completely every time, please charge the battery when the display shows red light, which can increase the cycle life of the battery.
 3. Please clean the bike regularly, to ensure the safety riding of children and also to keep the bike in the best state.
 4. Please always check the performance of the brakes and ensure it's good.
- Attention: please increase the braking distance in rainy, snowy days or downhill riding.
5. After each riding, please charge the battery to keep it in the best condition.
 6. The front and rear wheels should adjust the lock nut regularly to prevent the wheels from locking or wobbling.

⚠ WARNING:

Use caution as misusing or mishandling the battery may cause a FIRE or EXPLOSION which may result in personal injury, property damage, or death. The user must have an appropriate understanding of the potential dangers of lithium ion battery before purchase and usage. No express or implied guarantee of compatibility, suitability, or fitness for any particular purpose or device can be made. This battery is manufactured and sold for the intended use of system integrations with proper protection circuitry or battery packs with a BMS (battery management system) or PCB (circuit board/module). This battery is neither designed nor intended to be used with an E-CIGARETTE, VAPORIZER, or similar device and MUST NOT be used with such devices due to RISK OF FIRE or EXPLOSION. If purchasing this battery for resale purposes, you MUST forward ALL warnings to ALL customers for their reference and safety!

- DO NOT USE WITH E-CIGARETTE, VAPORIZER, OR SIMILAR DEVICE
- DO NOT STORE BATTERY LOOSE OR IN A POCKET, PURSE, ETC. ALWAYS USE A PROTECTIVE CASE OR BOX FOR STORAGE AND TRANSPORT
- WHEN NOT IN USE, ALWAYS STORE NON SPILLABLE LEAD ACID ION BATTERIES IN THE PROTECTIVE CASE/BOX.
- Misusing or mishandling Non Spillable lead acid ion batteries can pose a SERIOUS RISK of PERSONAL INJURY, PROPERTY DAMAGE.
- BATTERIES MAY EXPLODE, BURN, OR CAUSE A FIRE IF MISUSED OR MISHANDLED
- Usage of batteries is AT YOUR OWN RISK!
- ONLY use with proper protection circuitry
- DO NOT short circuit intentionally or unintentionally
- KEEP AWAY from metal/conductive objects to prevent short circuiting
- DO NOT use if battery is damaged in any way
- DO NOT over-charge or charge above the maximum voltage rating
- DO NOT over-discharge or exceed the continuous discharge rating
- DO NOT modify, disassemble, puncture, cut, crush, or incinerate
- DO NOT expose to liquids or high temperatures
- DO NOT solder onto battery, spot weld only
- DO NOT use force to install or install in reverse/backwards
- ONLY use within manufacturer's specification
- KEEP AWAY from pets and children
- ALWAYS charge in or on a fire-proof surface and never leave batteries charging unattended
- ONLY use a smart charger designed for this specific type of battery
- DO NOT mix and match brands and models, old and new, used and unused batteries
- STOP immediately if while charging/storing/using the battery it emits an unusual smell, feels hot, changes color or shape, or appears abnormal in any way
- It is your responsibility to determine that your charger or device is functioning properly
- If exposed to battery electrolyte, flush with water immediately and/or immediately contact a physician or emergency services
- DO NOT throw away in trash; contact your local jurisdiction for proper recycling or disposal
- Resellers MUST forward ALL warnings to ALL customers for their reference and safety

BATTERY DISPOSAL

Battery Recycling - Recycling Ebike battery



Ride on toys, electric bikes and electric scooters - we all have them and we all will have to replace our batteries at some point, or perhaps already have.

What to do with those used electric kids car batteries?

You are not allowed to put them out with the trash and can't just toss them in the river or bury them in the back yard because it is devastating to the environment and the public health, not to mention illegal according to Federal law (40 CFR part 273). Most states have their own laws prohibiting the disposal of rechargeable batteries, as well. So, the big question - what to do with the old batteries?

The answer: recycle them!

You can take your used rechargeable batteries to one of your local Department of Sanitation's Household Special Waste Drop-off Sites. They offer battery recycling information for Nickel Cadmium (Ni-Cd), Nickel Metal Hydride (Ni-MH), Lithium Ion (Li-ion), or Small Sealed Lead (Pb) weighing 2 pounds or less.

Since most of us use lead batteries weighing much more than 2 pounds, check out your own city's Department of Sanitation web page and see what they have to offer - or else just call them. Another option is retail stores, like auto parts stores or service outlets, which sell new Sealed Lead Acid batteries. Most will likely accept a small number (one or two) of spent Sealed Lead Acid batteries for recycling.

Tip: When transporting batteries be sure to eliminate the terminal contacts by either placing the battery in a plastic bag or wrapping black electrical tape around them