

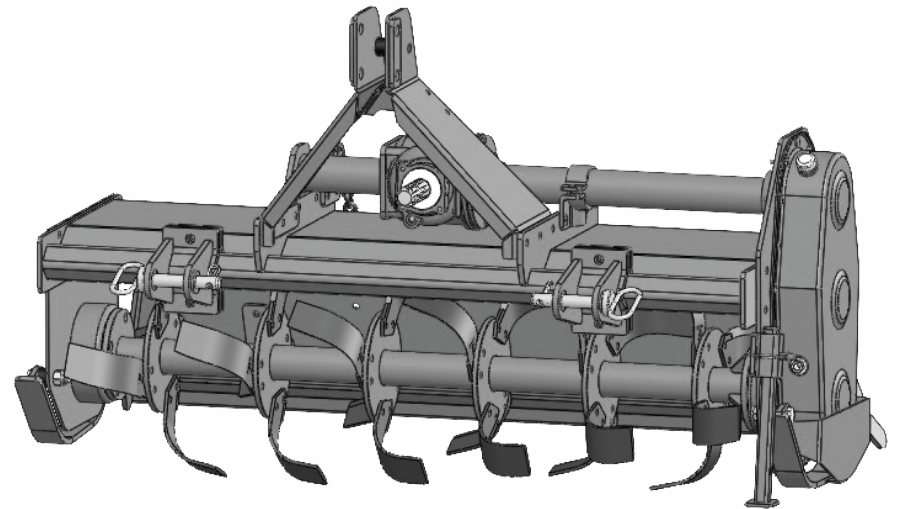

ROTARY TILLER

OPERATION AND ASSEMBLY MANUAL

RTFK4CL



For more information about
Proposition 65, please visit;
<https://www.p65warnings.ca.gov/>

4000625

Rev -01 | 03-11-2023

**For more information and questions, please contact
Customer Service : 1-844-338-8721**

INTRODUCTION

TO THE OWNER:

Read this manual before operating your implement. Keep this manual handy for reference. Require all operators to read this manual carefully and become acquainted with all adjustments and operating procedures before attempting to operate the equipment.

The equipment you have purchased has been carefully engineered and manufactured to provide dependable and satisfactory use. Like all mechanical products, it will require cleaning and upkeep. Lubricate the unit as specified. Please observe all safety information in this manual and safety decals on the equipment. Use only genuine service parts. Substitute parts will void the warranty and may not meet standards required for safe and satisfactory operation.

CUSTOMER INFORMATION

Name _____

Purchased From _____

Date Purchased _____

Model _____

Serial _____

PREPARATION CHECKLIST

Verify the following before operating your Rotary Tiller

- | | |
|---|--|
| <input type="checkbox"/> 1. Implement is completely assembled. | <input type="checkbox"/> 6. Check PTO driveline. Make sure it is the correct length to operate rotary tiller with intended tractor. |
| <input type="checkbox"/> 2. Gearbox is filled with oil and checked for possible leaks. | <input type="checkbox"/> 7. All decals in place and legible. |
| <input type="checkbox"/> 3. All fittings are lubricated. | <input type="checkbox"/> 8. Overall condition good. (i.e. paint, welds) |
| <input type="checkbox"/> 4. All shields in place and in good condition. | <input type="checkbox"/> 9. Operator's manual has been given to owner and the owner has been instructed on the safe and proper use of the Rotary Tiller. |
| <input type="checkbox"/> 5. All fasteners torqued to specifications in torque chart. (Pg. 28) | |

**For more information and questions, please contact
Customer Service : 1-844-338-8721**

Safety.....	1
Description.....	9
Safety Instruction Decals.....	10
Assembly.....	12
Attaching to a Tractor.....	15
Modify PTO Driveline.....	16
Operating.....	19
Maintenance.....	20
Storage / Product Specifications.....	21
Parts.....	22
Torque Specifications.....	28
Troubleshooting.....	29
Warranty.....	30
Notes.....	32

SAFETY

Safety is a primary concern in the design and manufacturing of our products. Unfortunately, our efforts to provide safe equipment can be eliminated by an operator's single careless act.

In addition to the design and configuration of equipment, hazard control and accident prevention are dependent upon the awareness, concern, judgment, and proper training of personnel involved in the operation, transport, maintenance and storage of equipment.

It has been said "The best safety device is an informed, careful operator." We ask you to be that kind of operator.

Throughout this manual, the term **IMPORTANT** is used to indicate that failure to observe procedures can cause damage to equipment. The terms **CAUTION**, **WARNING** and **DANGER** are used in conjunction with the Safety-Alert Symbol, (a triangle with an exclamation mark), to indicate the degree of hazard for items of personal safety.



This Safety-Alert Symbol indicates a hazard and means **ATTENTION!**
BECOME ALERT! YOUR SAFETY IS INVOLVED!

**DANGER**

Indicates an imminently hazardous situation that, if not avoided, will result in death or serious injury.

**WARNING**

Indicates a potentially hazardous situation that, if not avoided, could result in death or serious injury, and includes hazards that are exposed when guards are removed.

**CAUTION**

Indicates a potentially hazardous situation that, if not avoided, may result in minor or moderate injury.

IMPORTANT

Indicates that failure to observe can cause damage to equipment.

NOTE

Indicates helpful information.

TRAINING

Safety instructions are important! Read all attachments and power unit manuals; follow all safety rules and safety decal information. (Replacement manuals and safety decals are available) Failure to follow instructions or safety rules can result in serious injury or death.

If you do not understand any part of this manual and need assistance, please contact Customer Service 1-844-338-8721.

Know your controls and how to stop the engine and implement quickly in an emergency. Operators must be instructed in and be capable of the safe operation of the equipment, its attachments, and all controls. Do not allow anyone to operate this equipment without proper instructions.

Never allow children or untrained persons to operate equipment.

PREPARATION

Check that all hardware is properly installed.

Always tighten to torque chart specifications unless instructed otherwise in this manual.

Always wear relatively tight and belted clothing to avoid getting caught in moving parts. Wear sturdy, rough-soled work shoes and protective equipment for eyes, hair, hands, ears, and head; wear respirator or filter mask where appropriate.

Make sure implement is properly secured, adjusted, and in good operating condition.

Make sure collar slides freely and is seated firmly in tractor PTO spline groove.

Before servicing equipment, check and adjust driveline length as instructed in Operator's Manual. Driveline must not bottom out or pull apart throughout the full range of the tractor hitch. Do not operate until driveline length is correct. Make sure driveline shield safety chain is attached as shown in this manual. Replace if damaged or broken. Check that driveline guards rotate freely on driveline before servicing equipment.

Before starting power unit, check all equipment driveline guards for damage. Replace any damaged guards.

Make sure all guards rotate freely on all drivelines. If guards do not rotate freely on drivelines, repair and replace bearings before servicing equipment. Inspect chain or rubber guards before each use. Replace if damaged.

Remove accumulated debris from this equipment, power unit, and engine to avoid fire hazard.

Power unit must be equipped with ROPS or ROPS cab and seat belt. Keep seat belt securely fastened. Falling off power unit can result in death from being run over or crushed. Keep foldable ROPS system in “locked up” position at all times.

A minimum of 20% of tractor and equipment weight must be on the tractor’s front wheels when implements are in transport position. Without this weight, tractor could tip over, causing personal injury or death. The weight may be attained with a loader, front wheel weights, ballast in tires or front tractor weights. Weigh the tractor and equipment. Do not estimate.

Make sure all safety decals are installed. Replace if damaged. (See Safety Decals section for location.)

Make sure shields and guards are properly installed and in good condition. Replace if damaged.

Inspect and clear area of stones, branches, or other hard objects that might be thrown, causing injury or damage.

STARTING AND STOPPING

Check the tractor master shield over the PTO (power take off) stub shaft. Make sure it is in good condition and fastened securely to the tractor. Purchase a new shield if old shield is damaged or missing.

All tractors that are not equipped with a “live” power takeoff (PTO) must be equipped with an over-running PTO clutch. These are available through most farm equipment stores.

NOTE: The addition of an over-running PTO clutch may change the length of the PTO driveline required. Be sure to refer to the instructions on the PTO driveline installation.

Be sure that the driveline system guarding is adequate.

Implement operating power is supplied from the tractor PTO. Refer to the tractor manual for PTO engagement and disengagement instructions.

Understand how to stop tractor and implement quickly in case of an emergency.

When engaging the PTO, the engine RPM should always be at idle speed. Once engaged and ready to start, raise PTO speed to 540-RPM and maintain throughout operation.

TRANSPORTATION

Power unit must be equipped with ROPS or ROPS cab and seat belt. Keep seat belt securely fastened. Falling off power unit can result in death from being run over or crushed. Keep foldable ROPS system in “locked up” position at all times.

A minimum of 20% of tractor and equipment weight must be on the tractor’s front wheels when implements are in transport position.

Without this weight, tractor could tip over, causing personal injury or death. The weight may be attained with a loader, front wheel weights, ballast in tires or front tractor weights. Weigh the tractor and equipment. Do not estimate. Always comply with all state and local lighting and marking requirements.

Never allow riders on power unit or implement. Do not operate PTO during transport.

Watch for hidden hazards on the terrain.

Do not operate or transport on steep slopes.

Do not operate or transport equipment while under the influence of alcohol or drugs.

When encountering rough terrain during transport, reduce tractor speed to minimize the horizontal movement of implement.

Stabilizer bars should be used during transport to reduce lateral movement of implement.

OPERATION

Do not allow bystanders in the area when operating, attaching, removing, assembling, or servicing equipment.

Never discharge directly toward people, animals, or property.

Ensure the rear guard assembly is in place to reduce the possibility of objects being thrown. This implement is intended for agricultural applications only. Do not operate within 300 feet of bystanders or public roads or highways.

Do not operate or transport equipment while under the influence of alcohol or drugs.

Keep hands, feet, hair, and clothing away from equipment while engine is running. Stay clear of all moving parts.

Operate only in daylight or satisfactory artificial light.

Always comply with all state and local lighting and marking requirements.

Never allow riders on power unit or implement.

Operate tractor PTO at 540 RPM. Do not exceed. Power unit must be equipped with ROPS or ROPS cab and seat belt. Keep seat belt securely fastened.

Falling off power unit can result in death from being run over or crushed. Keep foldable ROPS system in "locked up" position at all times.

Always sit in power unit seat when operating controls or starting engine. Securely fasten seat belt, place transmission in neutral, engage brake, and ensure all other controls are disengaged before starting power unit engine.

Do not operate PTO during transport.

Look down and to the rear and make sure area is clear before operating in reverse (reverse operation is not recommended).

Do not operate or transport on steep slopes.

Do not stop, start, or change directions suddenly on slopes.

Use extreme care and reduce ground speed on slopes and rough terrain.

Watch for hidden hazards on the terrain during operation.

Stop power unit and equipment immediately upon striking an obstruction. Turn off engine, remove key, inspect, and repair any damage before resuming operation.

Leak down or failure of mechanical or hydraulic system can cause equipment to lower.

MAINTENANCE

Before detaching power unit or performing any service or maintenance, follow these steps: disengage power to equipment, lower the 3-point hitch and all raised components to the ground, set parking brake, stop engine, remove key, and unfasten seat belt.

Before performing any service or maintenance, disconnect driveline from tractor PTO.

Before working underneath, carefully read Operator's Manual instructions, disconnect driveline, raise implement, securely block up all corners with jack stands, and check stability. Secure blocking prevents equipment from dropping due to hydraulic leak down, hydraulic system failures, or mechanical component failures.

Do not modify, alter, or permit anyone else to modify or alter the equipment or any of its components in any way.

Always wear relatively tight and belted clothing to avoid getting caught in moving parts. Wear sturdy, rough-soled work shoes and protective equipment for eyes, hair, hands, ears, and head; wear respirator or filter mask where appropriate.

Make sure implement is properly secured, adjusted, and in safe operating condition.

Keep all persons away from operator control area while performing adjustments, service, or maintenance.

Never go underneath equipment (lowered to the ground or raised) unless it is properly blocked and secured. Never place any part of the body underneath equipment or between moveable parts even when the engine has been turned off.

Hydraulic system leak down, hydraulic system failures, mechanical failures, or movement of control levers can cause equipment to drop or rotate unexpectedly and cause severe injury or death. Follow Operator's Manual instructions for working underneath and blocking procedures.

Make certain all movement of equipment components has stopped before approaching for service.

Frequently check blades/tines/shanks. They should be sharp, free of nicks and cracks, and securely fastened.

Do not handle blades/tines/shanks with bare hands. Careless or improper handling may result in serious injury.

STORAGE

Block equipment securely for storage.

Keep children and bystanders away from storage area.

Follow manual instructions for storage.

Always use a tractor to position equipment for storage. Never attempt to move equipment by hand.

EQUIPMENT SAFETY GUIDELINES

Safety of the operator and bystanders is one of the main concerns in design and development. However, accidents can occur which could have been avoided by a few seconds of thought and a more careful approach to handling equipment. You, the operator, can avoid many accidents by observing the following precautions and insist those working with you, follow them.

In order to provide a better view, certain photographs or illustrations in this manual may show an assembly with a safety shield removed. However, equipment should never be operated in this condition. Keep all shields in place. If shield removal becomes necessary for repairs, replace the shield prior to use.

Replace any safety sign that is illegible or missing. Location of such safety signs are indicated in this manual.

Never use alcoholic beverages or drugs that can hinder alertness or coordination while operating this equipment. Consult your doctor about

operating this machine while taking prescription medications.

Under no circumstances should children under the age of 18 be allowed to operate this equipment. Do not allow persons to operate or assemble this unit until they have read this manual and have developed a thorough understanding of the safety precautions and how it works. Review the safety instructions with all users annually.

This equipment can be dangerous to children and persons unfamiliar with its operation. The operator should be a responsible, properly trained and physically able person familiar with farm machinery and trained in this equipment's operations.

Use a tractor equipped with a Roll Over Protective System and seat belts. (ROPS)

Never exceed the limits of a piece of machinery. If its ability to perform a job safely, is in question, DO NOT TRY IT.

Do not modify the equipment in any way. Unauthorized modification could result in serious injury or death and may impair the function and life of the equipment.

In addition to the design and the confirmation of this implement, including safety signs and safety equipment, hazard control and accident prevention are dependent upon the awareness, concern, prudence, and proper training of personnel involved in the operation, transport, maintenance, and storage of the machine. Refer also to safety messages and operation instruction in each of the appropriate sections of the tractor and implement manuals. Heed the safety signs affixed to both the tractor and implement.

DESCRIPTION

GENERAL DESCRIPTION

Your Rotary Tiller has been carefully designed for cultivating and stirring up soil for gardens, food plots and other tillage needs. This manual is provided to give you the necessary operation and maintenance instructions for keeping your rotary tiller in excellent operating condition. Please read this manual thoroughly. Understand the purpose of the controls and how to use them. Observe all safety precautions on the machine and as noted throughout this manual. If any assistance or additional information is needed, contact us at 1-844-338-8721.

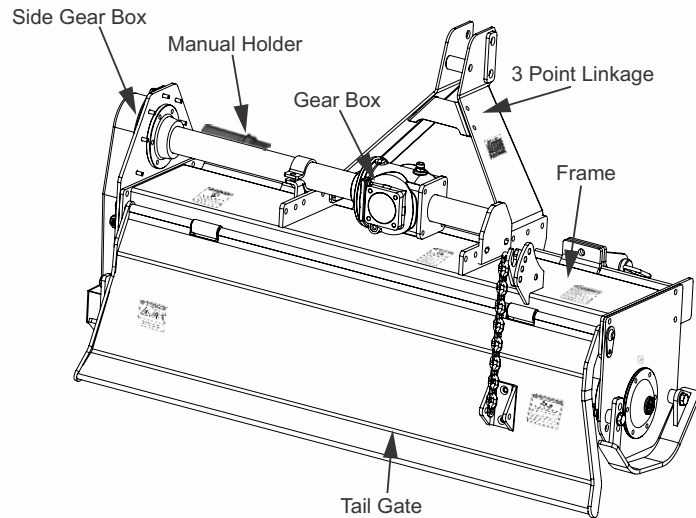
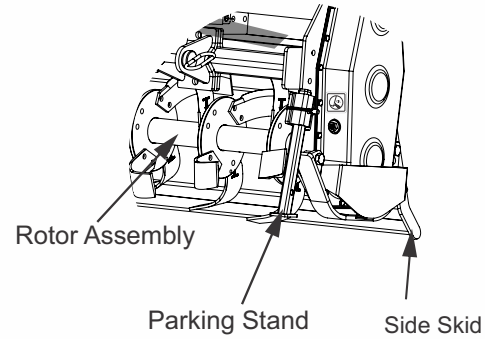

NOTICE

All information, illustrations, and specifications in this manual are based on the latest information available at the time of publication. Because we are always striving to improve our products, the images could differ slightly from actual equipment. Specifications are subject to change without notice. We also reserve the right to make changes at any time without notice.

SAFETY AND INSTRUCTIONAL DECALS

⚠ SAFETY AND INSTRUCTIONAL DECALS ⚠

ATTENTION! BECOME ALERT! YOUR SAFETY IS INVOLVED!

Replace Immediately if Damaged!

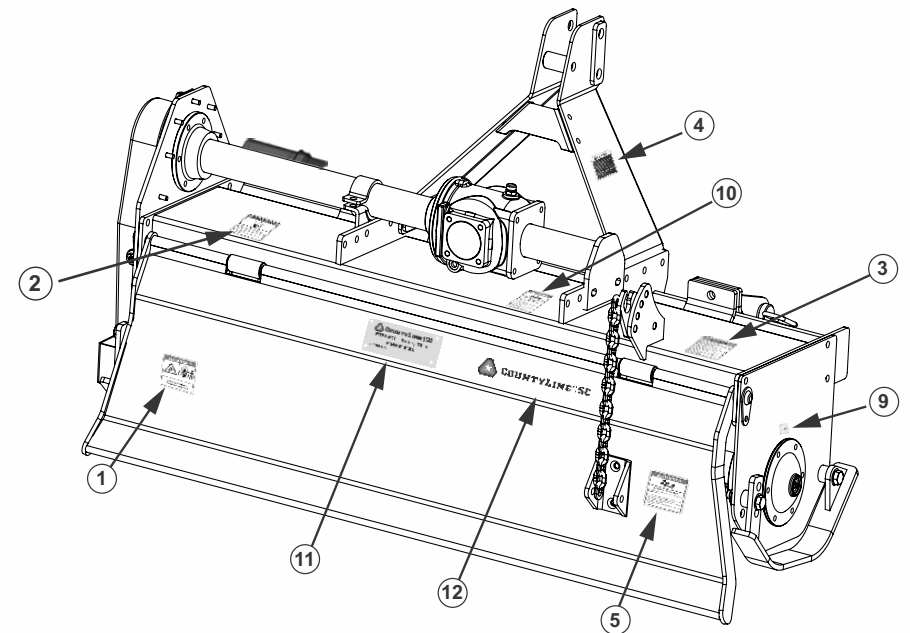
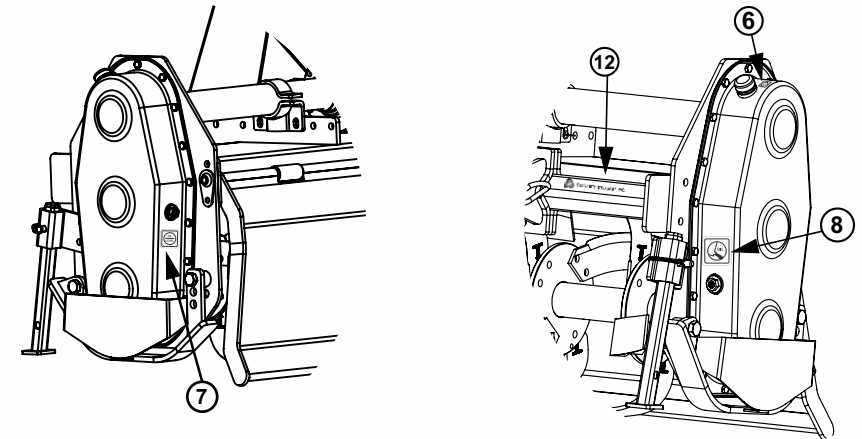

SAFETY AND INSTRUCTIONAL DECALS

ATTENTION! BECOME ALERT! YOUR SAFETY IS INVOLVED!

Replace Immediately if Damaged!



1

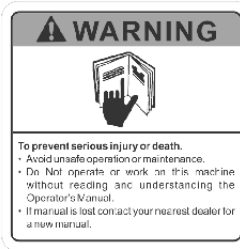

2

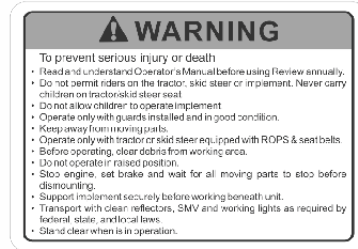

3



4



5



6



7



8



9



10

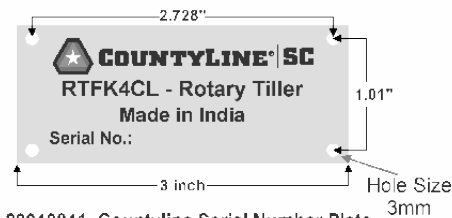

20040841_Countyline Serial Number Plate
1.20 MTS. Rotary Tiller (3 inch X 1.25 inch)

11



20040646_COUNTYLINE LABEL_RTFK4CL (7.5 INCH X 1.5 INCH)
For 4' Tiller - 7.5" 1.5"

12

Tools Needed : Socket & wrenches - 13mm, 16mm, 18mm, 19mm, 22mm & 24mm (IMPACT WRENCH IS PREFERRED).

1. With Rotary Tiller still in the rack, set it on a level ground.

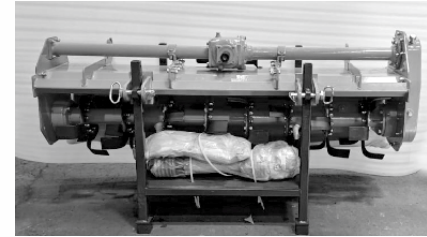

2. Remove packaged lift arms and skid shoes, and PTO shaft.

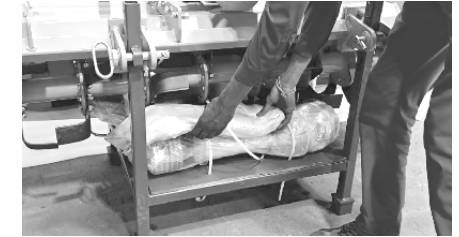

3. Insert lift strap and slowly lift until strap is tight.



4. Remove M14x40 bolts that secure the "H" braces to the tiller.



5. Install parking stand, with supplied hardware, and set at desired height.



6. Install skid shoes, with supplied hardware, and set at desired height. **Note:** Refer to parts drawing on page 22 for fastener installation order.



7. Slowly raise the tiller and remove hitch pin.

NOTE: Retain hitch pin for use with attaching implement to tractor. Discard shipping stand.

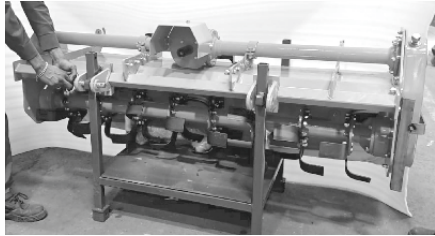

9. Install the 3-Point linkage (TPL) onto the rotary tiller using the 6 - M12X40 bolts on the inside of the frame assembly. Leave all fasteners loose until Assembly Step 13.

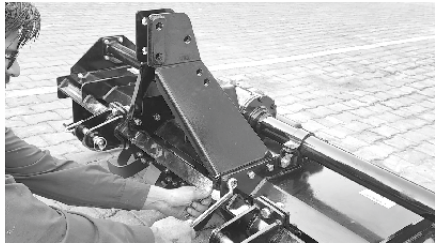

11. Install top link spacer.



8. Set the Rotary Tiller on level ground.

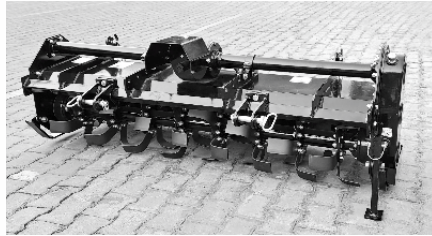

10. Install middle support plate. Leave fasteners loose until Assembly Step 13.



12. Install top link pin for alignment of the TPL plates.



13. In this order, tighten the following:

- a. Top link spacer
- b. TPL plates
- c. Middle support plate

14. Remove bolt from the PTO shaft. Slide the PTO shaft onto the gearbox and reinstall the bolt through the opening in the PTO shaft guard.

NOTE: Orientate bolt opening horizontally on bottom of the shaft.

15. Assembly of your Rotary Tiller is now complete. This unit is shipped with oil. Check oil levels prior to first use. Please read the operating and maintenance of this manual for checking and filling gearboxes with oil and lubricating instructions.

ATTACHING TO A TRACTOR

1. Place tiller and tractor on level ground.
2. Back tractor into position by lining up lift arms and Category-I pins on the tiller. Attach lift arms to Category-I pins and secure with lynch pins.
3. Attach top link using Category-I top link pin and lynch pin.
4. Attach PTO driveline and secure anti-rotation chains.
5. Once everything is securely attached, raise tiller off the ground and adjust the top link so the tiller sets level from front to back.
6. Determine if the PTO shaft needs to be shortened.

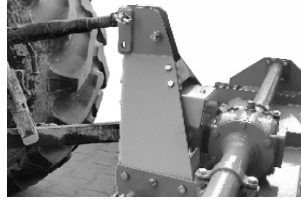

IMPORTANT: A driveline that is too long to fit between tractor and tiller will bottom out causing structural damage to the tractor and tiller.

7. Always check driveline collapsible length during initial setup, when connecting to a different tractor. More than one driveline may be required to fit all applications.
8. Make sure driveline is properly installed and level before checking driveline collapsible length.
9. With driveline level, measure 1" back from universal joint shield to end of outer driveline shield as shown in Figure 1 on Page 16. If measurement is less than 1", then shorten driveline using instructions provided in section "Sizing The PTO Shaft".

SIZING THE PTO SHAFT

Refer to Figure 1

1. Detach the driveline from tractor PTO shaft and pull outer and inner drivelines apart.
2. Reattach outer driveline to tractor PTO shaft. Pull on inner and outer drivelines to ensure universal joints are properly secured.
3. Hold inner and outer drivelines parallel to each other:
 - a. Measure 1" ("B" dimension) back from outer driveline universal joint shield and make a mark at this location on the inner driveline shield.
 - b. Measure 1" ("B" dimension) back from inner driveline universal joint shield and make a mark at this location on the outer driveline shield.
4. Remove driveline from tractor and gearbox shafts.
5. Measure from end of inner shield to scribed mark ("X" dimension). Cut off inner shield at the mark. Cut same amount off the inner shaft ("X1" dimension).
6. Measure from end of outer shield to scribed mark ("Y" dimension). Cut off outer shield at the mark. Cut same amount off the outer shaft ("Y1" dimension).
7. Remove all burrs.
8. Continue with "Check Driveline Maximum Length".

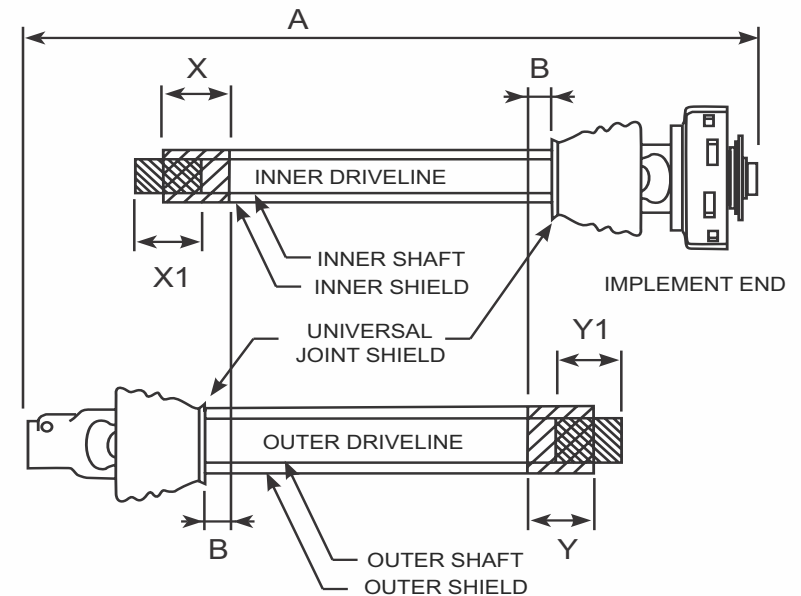

Figure-1 Driveline Shortening

CHECK DRIVELINE MAXIMUM LENGTH

Refer to Figure 2

Make sure driveline's collapsible length is acceptable.

The driveline maximum allowable length must, when fully extended, have a minimum overlap of the profile tubes by not less than 1/3 the free length with both inner and outer profile tubes being of equal length.

1. Apply multi-purpose grease to the inside of the outer shaft and reassemble the driveline.
2. Assemble the two driveline profiles together with 1/3 of the profile tubes overlapping as shown below. Once assembled, measure and record the maximum allowable length for future reference.
3. Attach inner driveline yoke to the tiller's gearbox shaft. Attach outer driveline yoke to the tractor's PTO.

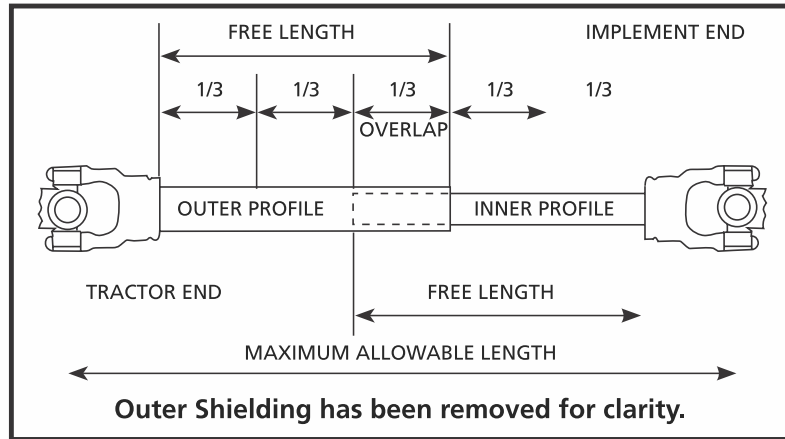

Figure 2 - Driveline Maximum Extended Length shaft.

4. Move yoke ends of driveline back and forth to insure they are secured to the tractor and tiller shafts. Reattach any end that is loose.

IMPORTANT: Small chains are supplied with the driveline. They must be attached to the inner and outer driveline shields and to the tiller and tractor to restrict shield rotation.
5. Hook driveline safety chain on the tractor end of driveline to tiller frame. Re-latch safety chain to the driveline shield.
6. Hook driveline safety chain on the Rotary Tiller end of driveline to the tiller frame. Re-latch safety chain to driveline shield.
7. Start tractor and raise Rotary Tiller just enough to remove support blocks.

8. Slowly engage tractor hydraulic 3-point control lever to lower the tiller while checking for sufficient drawbar clearance. Move drawbar in, aside or remove if required.
9. Raise and lower implement to find maximum extended driveline length. Check to make certain the driveline does not exceed maximum allowable length recorded in step 2.
10. If needed, set tractor 3-point lift height to stop driveline from exceeding maximum allowable length.
11. Continue with "Check Driveline Maximum Angle" below.

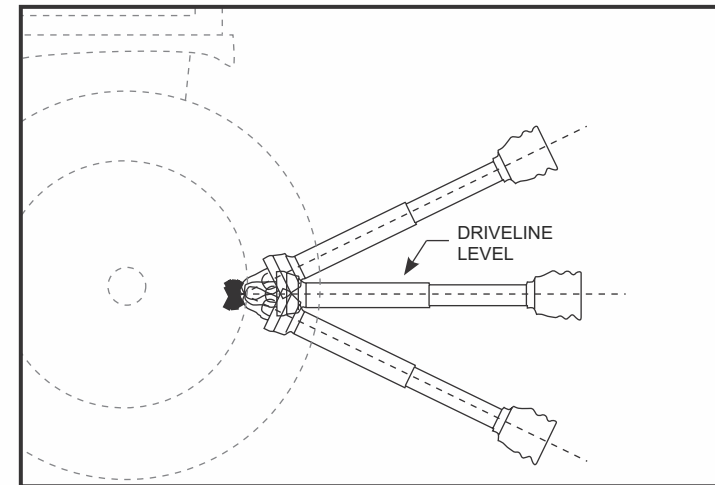

Figure 3 - Check Driveline Maximum Angle

CHECK DRIVELINE MAXIMUM ANGLE

Refer to Figure 3

IMPORTANT: To avoid premature driveline breakdown, do not exceed an angle of 25° up or down with the driveline while driveline is rotating. If needed, set tractor 3-point lift lever to limit driveline angle at a maximum of 25° up.

1. Raise and lower implement to find maximum driveline angle. Check to make certain the driveline does not exceed 25° up or down.
2. If needed, set tractor 3-point lift height to keep driveline from exceeding 25° up.

OPERATING INSTRUCTIONS

1. Read, understand, and follow the safety information on training, preparation, starting and stopping, operation, transportation, maintenance and storage at the beginning of this manual.
2. With the rotary tiller positioned on level ground, adjust the tractor lift arms so that when lifted, the rotor bar remains parallel to the ground.
3. With the rotary tiller attached to the tractor, raise and support the tiller with suitable blocks. Adjust the skids, located on the sides of the tiller. The adjustment bolts for both right and left sides should be positioned in the same adjustment hole. This allows the tiller to till the same depth on each side. Adjust the tail gate, with regulating chains, until the desired mulching effect is found.
4. Raise the tiller and remove the blocks. Lower the tiller to the ground.
5. With the tractor at idle RPM and the tiller lifted off of the ground, engage PTO and slowly advance throttle to 540 PTO RPM.

NOTE: Rotary tiller is designed to run at 540 PTO RPM only.

 **WARNING** Never attempt to adjust the rotary tiller while the tractor is running.

6. Select a low gear for the tractor and begin to move forward. Tractor ground speed is to be controlled by gear selection only and not engine speed. As the tractor moves forward, slowly lower the tiller down. Allow the tiller tines to gradually engage the ground.

IMPORTANT: Do not allow the tractor engine or rotary tiller to bog down or stall. This causes undue wear and tear on the tiller and tractor. If this continues to happen reduce ground speed and raise tilling depth of rotary tiller. Never attempt to remove objects from the rotor bar until the tractor has been shut down and the tiller tines have completely stopped.

IMPORTANT: *Never travel at a fast ground speed while using the tiller, this could damage it. Never attempt to turn the tractor or travel in reverse with the PTO engaged and the tiller in the ground. Always raise the tiller out of the ground when backing up or attempting to turn. Failure to do so may cause damage to the tiller.*

7. After each use clean all debris from the tiller tines. Replace any missing or illegible safety decals. Inspect for any damaged or worn parts and replace before next use. Store rotary tiller in a dry environment.

MAINTENANCE

1. Periodically check and maintain proper gear oil level.
 - a. The top gearbox has a dipstick. Proper oil level should be at or above the bottom line on the dip stick.
 - b. There is a sight glass on the side gearbox. You should be able to see oil in the sight glass to maintain proper oil level.
2. Every 8 hours, grease “hub”, PTO shaft universal joints, PTO shaft safety shield and PTO telescoping surface.

NOTE: Use only a grade Type-II grease. Do not grease the slip clutch assembly.

3. Before each use check to make sure all safety shields are installed and working properly.
4. Check tiller tines for cracks and breaks before every use.
5. Periodically check all nuts and bolts to insure they are tight and secure.
6. Periodically loosen torque spring bolts and allow slip clutch to slip for approximately two (2) revolutions. Loosen the bolts until the springs lose contact with the flange yoke. This ensures that the slip clutch is not in a “locked” position.
7. Make sure that the clutch slips.
8. To re-tighten the slip clutch, tighten the torque spring bolts until the nut makes contact with the flange yoke and further tighten one and a half turns (1-1/2). This is a good starting point; further adjustments may need to be made based on soil conditions.





NOTE: Do not over or under tighten slip clutch assembly or damage may occur.

STORAGE

IMPORTANT: When the unit is going to be stored for an extended amount of time please perform the following steps to keep the oil seals from deteriorating.

- Spray shaft extensions with a suitable dry film or similar preservative.
- Pack grease around seal to prevent drying and cracking.
- Fill the gearbox with enough oil so that it covers the top of the input seal.
- Remember to drain the oil back to the correct level before using again.

PRODUCT SPECIFICATIONS

DESCRIPTION	RTFK4CL
Tillage Width	4 ft.
Gear Box (rpm) 	Single Speed
Side Transmission	Gear Drive
Type of Blades	L Type
No. of Blades	24
PTO Speed (RPM) 	540
Rotor Speed (RPM)	216
Gear Box Overload Protection	Slip Clutch
Weight (Lbs. Approx.) 	470
Tractor Power (HP) 	18-30

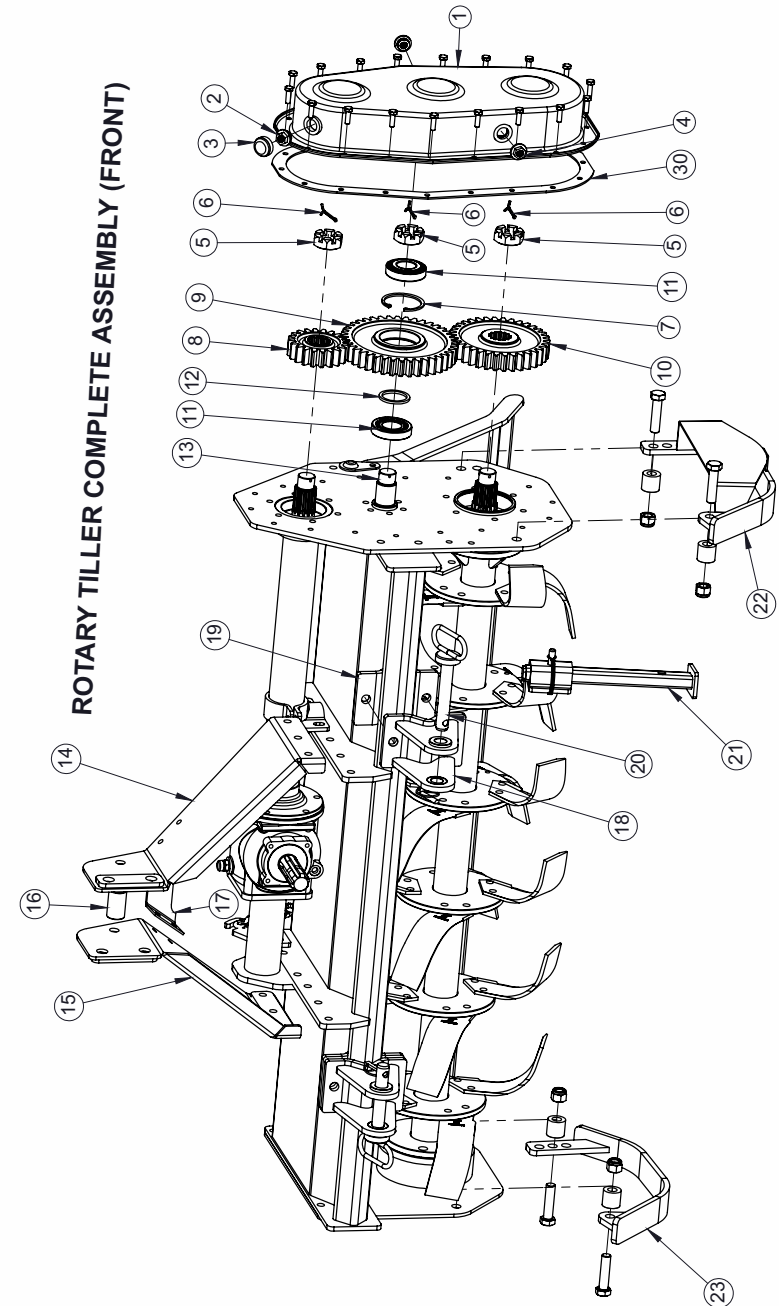

ROTARY TILLER COMPLETE ASSEMBLY (REAR)

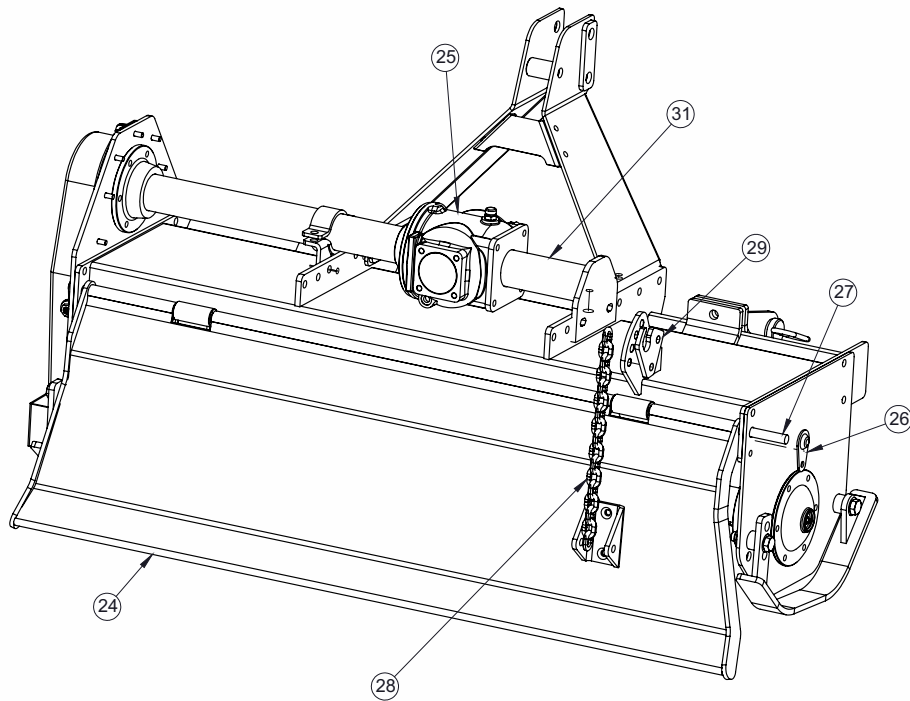

ROTARY TILLER COMPLETE ASSEMBLY			
SR. NO.	ITEM CODE	DESCRIPTION	QTY.
1	9001115	CHAIN COVER (ORANGE)	1
2	9000965	BREATHER NUT M22X1.5	1
3	9000966	BREATHER VALVE	1
4	9000967	DRAIN PLUG	1
5	9000968	CASTLE NUT M30X1.5	2
6	9000969	SPLIT PIN 1/8X2.5 INCH	2
7	9000970	INTERNAL CIRCLIP-72MM	1
8	9000971	SPUR GEAR 20T-14S	1
9	9000972	SPUR GEAR 40T	1
10	9000973	SPUR GEAR 34T-14S	1
11	S-132	BEARING 30207	2
12	9000975	SPACER 50 OD X 40 ID X 5 MM	1
13	9000976	IDLER PIN	1
14	9000977	TPL PLATE LHS (ORANGE)	1
15	9000979	TPL PLATE RHS (ORANGE)	1
16	9000981	TOP LINK BUSH	1
17	9000982	MIDDLE SUPPORT PLATE (ORANGE)	1
18	9000984	FRONT LINK BRACKET UPPER (ORANGE)	2
19	9000986	FRONT LINK BRACKET LOWER (ORANGE)	2
20	P7234	TILLER PIN 22X145 CAT-1	2
21	9000988	RT STAND (ORANGE)	1
22	9000990	DEPTH SKID ASSEMBLY (LHS) (ORANGE)	1
23	9000992	DEPTH SKID ASSEMBLY (RHS) (ORANGE)	1
24	9001276	TAIL GATE ASSEMBLY 4 FT (ORANGE)	1
25	9000997	GEAR BOX ASSEMBLY 4 FT (ORANGE)	1
26	9001240	PLANK ROD SUPPORT PLATE	2
27	9001241	PLANK ROD 4 FT	2
28	9001009	REAR PLANK CHAIN 4 FT	1
29	9001011	CHAIN HOOK PLATE 4 FT (ORANGE)	1
30	9001237	GASKET GEAR COVER	1
31	9001283	GEAR BOX SIDE SUPPORT PIPE ASSY. (ORANGE)	1

SIDE PLATE AND ROTOR ASSEMBLY

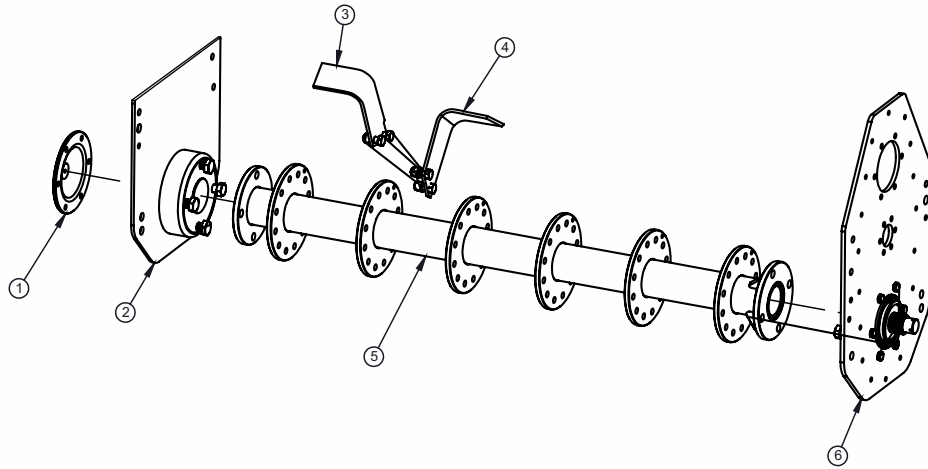

SIDE PLATE AND ROTOR ASSEMBLY			
SR. NO.	ITEM CODE	DESCRIPTION	QTY.
1	9001000	DEAD HUB COVER	1
2	9001277	DEAD HUB ASSEMBLY COMPLETE (ORANGE)	1
3	9001238	HOE RHS (L TYPE) W/ FINE THREAD HARDWARE	1
4	9001239	HOE LHS (L TYPE) W/ FINE THREAD HARDWARE	1
5	9001278	ROTOR ASSEMBLY COMPLETE 4 FT (ORANGE)	1
6	9001113	RD HUB ASSEMBLY COMPLETE (ORANGE)	1

GEAR BOX ASSEMBLY

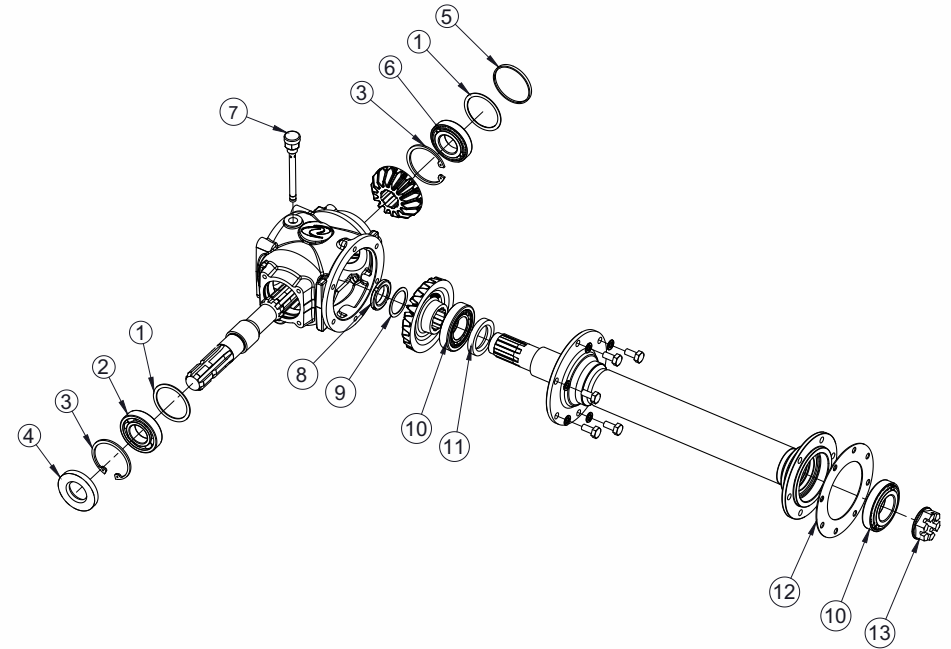

GEAR BOX ASSEMBLY			
SR. NO.	ITEM CODE	DESCRIPTION	QTY.
1	9001010	SHIM 71 MM	2
2	S-102	BEARING 6207	1
3	9000970	CIRCLIP 72 MM	2
4	9001012	OIL SEAL 35X72X10	1
5	9001013	CUP SEAL 72X10	1
6	S-132	BEARING 30207	1
7	9001014	DIP STICK	1
8	9001015	RING NUT M30X1.5	1
9	9001016	SHIM 40MM	1
10	9001017	BEARING 30208	2
11	9001018	OIL SEAL 40X62X10	1
12	9001019	GASKET	1
13	9000968	CASTLE NUT M30X1.5	1

PTO DRIVELINE PARTS LIST (4-FOOT)

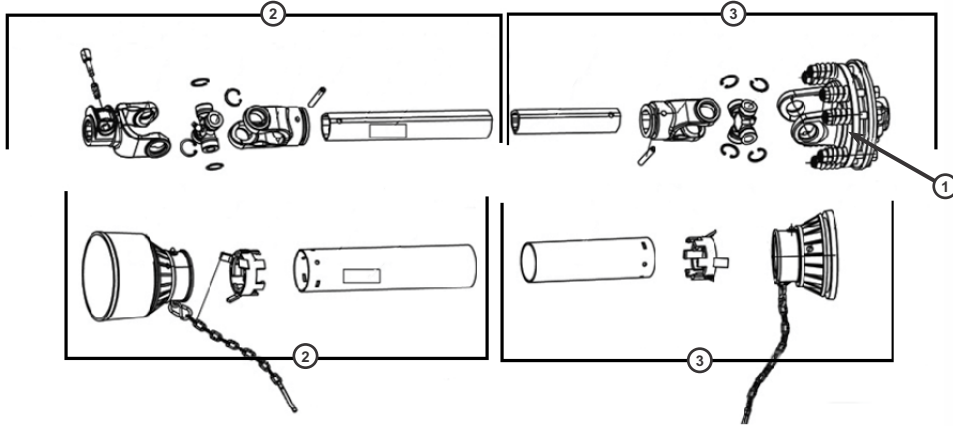

PTO DRIVELINE PARTS LIST (4-FOOT)			
SR. NO.	ITEM CODE	DESCRIPTION	QTY.
1	FF0.3	FRICITION DISK (2PK)	1
2	T12TPTO	TRACTOR 1/2 PTO	1
3	I12YPTO	IMPLEMENT 1/2 PTO	1
2 & 3	4-30QDTL	PTO SHAFT ASSEMBLY	1

Proper torque for American fasteners used on manufactured implement.
Recommended Torque in Foot Pounds (Newton Meters).*

AMERICAN
Bolt Head Markings

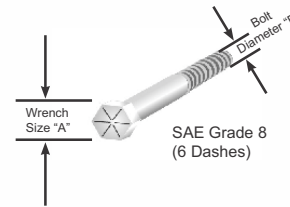

WRENCH SIZE(IN.)"A"	BOLT DIAMETER (IN.)"B" AND THREAD SIZE	SAE GRADE 2	SAE GRADE 5	SAE GRADE 8
7/16	1/4 -20 UNC	6 (7)	8 (11)	12 (16)
7/16	1/4 - 24 UNF	6 (8)	10 (13)	14 (18)
1/2	5/16 -18 UNC	11 (15)	17 (23)	25 (33)
1/2	5/16 - 24 UNF	13 (17)	19 (26)	27 (37)
9/16	3/8 - 16 UNC	20 (27)	31 (42)	44 (60)
9/16	3/8 -24 UNF	23 (31)	35 (47)	49 (66)
5/8	7/16 -14 UNC	32 (43)	49 (66)	70 (95)
5/8	7/16 - 20 UNF	36 (49)	55 (75)	78 (106)
3/4	1/2 - 13 UNC	49 (66)	76 (103)	106 (144)
3/4	1/2 - 20 UNF	55 (75)	85 (115)	120 (163)
7/8	9/16 -12 UNC	70 (95)	109 (148)	153 (207)
7/8	9/16 - 18 UNF	79 (107)	122 (165)	172 (233)
15/16	5/8 - 11 UNC	97 (131)	150 (203)	212 (287)
15/16	5/8 - 18 UNF	110 (149)	170 (230)	240 (325)
1-1/8	3/4 - 10 UNC	144(195)	266 (360)	376 (509)
1-1/8	3/4 - 16 UNF	192 (260)	297 (406)	420 (569)
1-5/16	7/8 - 9 UNC	166 (225)	430 (583)	606 (821)
1-5/16	7/8 - 14 UNF	184 (249)	474 (642)	668 (905)
1-1/2	1-8 UNC	250 (339)	644 (873)	909 (1232)
1-1/2	1 - 12 UNF	274 (371)	705 (955)	995 (1348)
1-1/2	1-14 UNF	280 (379)	721 (977)	1019 (1381)
1-11/16	1-1/8 - 7 UNC	354 (480)	795 (1077)	1288 (1745)
1-11/16	1-1/8 -12 UNF	397 (538)	890 (1206)	1444 (1957)
1-7/8	1-1/4 - 7 UNC	500 (678)	1120 (1518)	1817 (2462)
1-7/8	1-1/4 - 12 UNF	553 (749)	1241 (1682)	2013 (2728)
2-1/16	1-3/8 - 6 UNC	655 (887)	1470 (1992)	2382 (3228)
2-1/16	1-3/8 -12 UNF	746 (1011)	1672 (2266)	2712 (3675)
2-1/4	1-1/2 - 6 UNC	870 (1179)	1950 (2642)	3161 (4283)
2-1/4	1-1/2 - 12 UNF	979 (1327)	2194 (2973)	3557 (4820)

METRIC

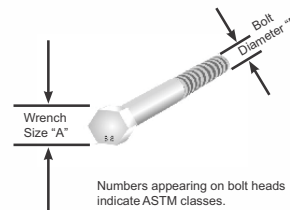

*Use 75% of the specified torque value for plated fasteners. Use 85% of the specified torque values for lubricated fasteners.

Proper torque for metric fasteners used on manufacturer implement.
Recommended Torque in Foot Pounds (Newton Meters).*

WRENCH SIZE (mm) "A"	BOLT DIA. (mm) "B"	ASTM 4.6	ASTM 8.8	ASTM 9.8	ASTM 10.9
8	5	1.8 (2.4)		5.1 (6.9)	6.5 (8.8)
10	6	3 (4)		8.7 (12)	11.1 (15)
13	8	7.3 (10)		21.1 (29)	27 (37)
16	10	14.5 (20)		42 (57)	53 (72)
18	12	25 (34)	74 (100)	73 (99)	93 (126)
21	14	40 (54)	118 (160)	116 (157)	148 (201)
24	16	62 (84)	167 (228)	181 (245)	230 (312)
30	20	122 (165)	325 (440)		449 (608)
33	22		443 (600)		611 (828)
36	24	211 (286)	563 (763)		778 (1054)
31	27		821 (1112)		138(1542)
46	30	418 (566)	1119 (1516)		1547(2096)

PROBLEM	POSSIBLE CAUSE	POSSIBLE SOLUTION
Cannot attach PTO shaft to the tractor	PTO shaft is too long, PTO yoke attachment pin is seized.	Cut PTO shaft per OM instructions, lubricate attachment pin.
Tillage depth insufficient	Tractor is holding tiller up, Tractor has insufficient power, skid shoes preventing lowering, tines are worn, ground is too hard.	Adjust lift arm settings on tractor, increase tractor PTO speed, adjust tiller skidshoes, replace tines, make multiple passes.
Soil is not tilled fine enough	Ground speed too fast, PTO speed too slow, tines assembled incorrectly.	Slow tractor ground speed, Increase tractor PTO speed, check tine assembly.
Driveline vibrates	Universal joint is worn, debris wrapped around tine bar, driveline is at extreme angle.	Replace universal joint/cross bearing, remove debris, lower tiller and adjust tractor lift stop.
Constant abnormal gearbox noise	Low oil level, worn gears, gearbox bearings.	Check oil level, replace gears/gearbox, replace bearings.
Tiller makes intermittent/ abnormal noise	Tines are loose, gearbox has damaged tooth, debris is wrapped around tine bar.	Tighten tines, replace damaged gear, clear debris.
Gearbox is overheating	Oil level is low, gearbox needs service, ventplug is seized, tiller load is too great.	Check oil level, replace old oil, replace ventplug, reduce ground speed/tilling depth.
Oil Leaking from gearbox	Seals and or gaskets are damaged, gearbox is overfilled with oil.	Replace seals or gaskets, drain oil to correct level.
Rotor will not turn	Tractor PTO is not engaged, gear drive has damage, friction clutch not adjusted properly.	Engage tractor PTO, inspect and repair gears, reduce tiller load or adjust clutch.
Tiller shaking	Ground is compacted and/or dry, debris entangled in tines.	Make multiple passes with shorter tilling depth, irrigate soil, clear debris.
Rear tailgate impacts tines	Tailgate adjustment chain in wrong position.	Adjust tailgate adjustment chain to hold tailgate higher.

WARRANTY

MANUFACTURER’S LIMITED WARRANTY

Manufacturer warrants to the original purchaser that the purchased product is free from defects in material and workmanship for a period of 1 year commencing on the date of original purchase, as evidenced by the original receipt, and will, at its option, repair, replace, or issue credit for any product or part found to be defective.

This limited warranty shall only apply if this product has been operated and maintained in accordance with the Operator’s Manual furnished with the product, and has not been subject to misuse, abuse, commercial or industrial use, neglect, improper maintenance, alteration or accident, or which has been used for a purpose for which the product was not designed. Damage resulting from the installation or use of any part, accessory, or attachment not approved by manufacturer, for use with the product covered by the owner’s manual, shall void the warranty as to any resulting damage.

This limited warranty is extended solely to the original purchaser of the product. Should the original purchaser sell or otherwise transfer this product to a third party, this warranty does not transfer to the third party in any manner.

HOW TO MAKE A CLAIM:

To obtain warranty service through a local authorized retailer, a customer must present the following within thirty (30) days of product failure:

1. Proof of purchase within 1 year of purchase date.
2. Photographs of or return of the actual product in question.
3. Photograph of UPC label.

After receipt of the above information, if the product is alleged to be defective, manufacturer will process the claim and issue a Return Manufacturers Authorization number (RMA). Once an RMA number is issued, manufacturer will pick up the product from the authorized retailer and return to its facility for inspection.

Manufacturer will replace, repair, or issue credit for any product, upon examination by manufacturer at manufacturer’s facility, determined to be defective due to defects in material and workmanship.

For additional Warranty questions, please call : 1-844-338-8721

WARRANTY DISCLAIMER:

This limited warranty is in lieu of, and manufacturer disclaims and excludes any express and implied warranties with respect to the product including, without limitation, merchantability and fitness for a particular purpose. No other express warranty, whether written or oral, given by any person or entity, including a retailer, with respect to any product, shall bind manufacturer.

Manufacturer's exclusive liability for breach of the limited warranty, as set forth above, on the product shall be to repair or replace the product within the warranty period in accordance with the terms of this limited warranty. The choice of remedy shall belong solely to manufacturer. In no event shall manufacturer be liable for any loss or damages of any other kind, whether direct, incidental, consequential including lost profits, exemplary, special or otherwise, including without limitation, expenses incurred for substitute or replacement product or for rental expenses to temporarily replace a warranted product.

Under no circumstance shall recovery, of any kind, be greater than the amount of the purchase price of the product purchased. Customer assumes all risk and liability for loss, damage, or injury to customer or customer's property and/or the property of others arising out of the misuse or inability to use the product.

LEGAL RIGHTS:

This limited warranty gives you specific legal rights, and you may also have other rights which may vary from state to state. Some states do not allow any limitation on how long an implied warranty lasts or the exclusion or limitation of incidental or consequential damages, so the above limitations may not apply to you.