

ITEM # WPUMP1

1-Inch Water Pump 2-Cycle Engine Operating Instructions

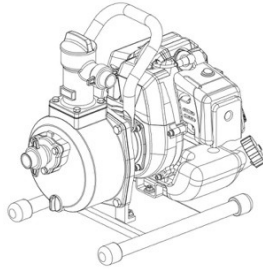

READ ALL INSTRUCTIONS AND WARNINGS BEFORE USING THIS PRODUCT.

This manual provides important information on proper operation & maintenance. Every effort has been made to ensure the accuracy of this manual. These instructions are not meant to cover every possible condition and situation that may occur. We reserve the right to change this product at any time without prior notice.

IF THERE IS ANY QUESTION ABOUT A CONDITION BEING SAFE OR UNSAFE, DO NOT OPERATE THIS PRODUCT!

HAVE QUESTIONS OR PROBLEMS? CONTACT CUSTOMER SERVICE.

If you experience a problem or need parts for this product, visit our website <http://www.buffalotools.com> or call our customer help line at 1-866-460-9436, Monday-Friday, 8 AM - 4 PM Central Time. A copy of the sales receipt is required.

FOR CONSUMER USE ONLY – NOT FOR PROFESSIONAL USE.

KEEP THIS MANUAL, SALES RECEIPT & APPLICABLE WARRANTY FOR FUTURE REFERENCE.

TABLE OF CONTENTS

RECOGNIZE SAFETY SYMBOLS, WORDS AND LABELS.....	3
IMPORTANT SAFETY INSTRUCTIONS	4
GENERAL PRODUCT SPECIFICATIONS	6
PACKAGE CONTENTS	6
SPECIFICATIONS	6
COMPONENTS.....	6
ASSEMBLY	6
PREPARING THE WATER PUMP FOR USE.....	7
STARTING THE WATER PUMP.....	7
BREAK-IN PERIOD.....	8
PRIMING THE WATER PUMP	8
MAINTENANCE	8
AIR FILTER MAINTENANCE.....	9
SPARK PLUG MAINTENANCE	9
STORAGE.....	10
PARTS DIAGRAM.....	11

2 YEAR LIMITED EMISSION-RELATED WARRANTY

THIS ENGINE MEETS U.S. EPA EMISSION STANDARDS UNDER 40 CFR 1054.625 .The emission-related limited warranty is valid for two (2) years. Keep the purchase receipt and mail in the product registration card for proof of purchase. Buffalo Corp limits emission-related warranty repairs to authorized service centers for owners located within 100 miles of an authorized service center. For owners located more than 100 miles from an authorized service center, Buffalo Corp will, in its sole discretion, either pay for shipping costs to and from an authorized service center, provide for a service technician to come to the owner to make the warranty repair, or pay for the repair to be made at a local non-authorized service center. The provisions of this paragraph apply only for the contiguous states, excluding the states with high-altitude areas identified in 40 CFR part 1068, Appendix III.

To exercise this warranty, DO NOT RETURN TO RETAILER. Instead, call Customer Service toll free at 1-866-460-9436 (email address info@buffalotools.com) and you will be instructed on where to take the engine for warranty service. Take the water pump and proof of purchase (your receipt) to the repair facility recommended by the Customer Service Representative. The warranty does not extend to water pumps damaged or affected by fuel contamination, accidents, neglect, misuse, unauthorized alterations, use in an application for which the product was not designed and any other modifications or abuse.

1 YEAR LIMITED WARRANTY (30 Day Limited Warranty for Commercial and Rental Purpose)

Water pumps are warranted to be free from defects in materials and workmanship for a period of 1 YEAR from date of original purchase. Buffalo Corp. is not liable for any indirect, incidental or consequential damages from the sale or use of this product. Any implied warranties are limited to 1 YEAR as stated, or as otherwise stated, in this written limited warranty. Some states do not allow the exclusion or limitation of incidental or consequential damages. Some states do not allow limitation on the length of an implied warranty. Buffalo Corp will repair or replace, at its discretion, any part that is proven to be defective in materials or workmanship under normal use during the 1 YEAR warranty period. Warranty repairs or replacements will be made without charge for parts or labor. Parts replaced during warranty repairs will be considered as part of the original product and will have the same warranty period as the original product. This warranty gives you specific legal rights, and you may have other rights that vary state to state.

RECOGNIZE SAFETY SYMBOLS, WORDS & LABELS

Warning and Important Safety Instructions appearing in this manual are not meant to cover all possible conditions and situations that may occur. Common sense, caution and care must be exercised when operating or cleaning tools and equipment.

Always contact your dealer, distributor, service agent or manufacturer about problems or conditions you do not understand.



This is the safety alert symbol. It is used to alert you to potential personal injury hazards. Obey all safety messages that follow this symbol to avoid possible injury or death.



DANGER indicates an imminently hazardous situation, which, if not avoided, will result in death or serious injury.



WARNING indicates a potentially hazardous situation, which, if not avoided, could result in death or serious injury.



CAUTION indicates a potentially hazardous situation, which, if not avoided, may result in minor or moderate injury.



CAUTION used without the safety alert symbol indicates a potentially hazardous situation, which, if not avoided, may result in property damage.

WARNING

GASOLINE IS HIGHLY FLAMMABLE AND EXPLOSIVE. YOU COULD BE BURNED OR SERIOUSLY INJURED IF THE GASOLINE IS IGNITED. Before refueling, stop the engine and keep heat, sparks and flame away. Handle fuel only outdoors. Do not fill the fuel tank above the upper limit line. Wipe up spills immediately.

DANGER

EXHAUST CONTAINS POISONOUS CARBON MONOXIDE GAS THAT CAN BUILD UP TO DANGEROUS LEVELS IN CLOSED AREAS. BREATHING CARBON MONOXIDE CAN CAUSE UNCONSCIOUSNESS OR DEATH. Never run the generator in a closed or even partly closed area where people may be present.

Notice Regarding Emissions:

Engines certified to comply with U.S. EPA emission regulations for SORE (Small Off Road Equipment) are certified to operate on regular unleaded gasoline and may include the following emission control systems: Three-Way Catalyst (TWC) (if equipped), and Engine Modifications (EM).

Legal Requirements:

Federal and/or State Occupational Safety and Health Administration (OSHA) regulations, local codes, and/or ordinances may apply to the intended use of this water pump. Consult a qualified electrician, electrical inspector, and/or the local agency having jurisdiction. Some areas require water pumps to be registered with local utility companies. Additional regulations may apply if this water pump will be used at a construction site.

IMPORTANT SAFETY INSTRUCTIONS – SAVE THESE INSTRUCTIONS

STOP!

Before using this product, if you have any questions regarding the hazard and safety notices listed in this manual and/or on this product, call 1-866-460-9436, Monday - Friday, 8 AM - 4 PM Central Time.

DANGER

Carbon Monoxide Gas: When in operation, the exhaust from this product contains poisonous carbon monoxide gas. Carbon monoxide gas is both odorless and colorless AND may be present even if you do not see or smell gas. Breathing this poison gas can lead to headaches, dizziness, drowsiness, loss of consciousness and eventually death.

- Use this product ONLY outdoors in non-confined areas.
- Keep at least several feet of clearance on all sides to allow proper ventilation for this product.

WARNING

Flammable Gasoline: This product may emit highly flammable and explosive gasoline vapors, which can cause severe burns or even death. A nearby open flame can lead to an explosion even if not directly in contact with gasoline.

- Do not operate this product near open flame.
- Do not smoke near this product.
- Always operate this product on a firm, level surface.
- **Gasoline is highly flammable and explosive. Handling fuel can result in serious injury or burns.**
- Always shut down this product before refueling. Refuel in a well-ventilated area. Keep heat, sparks and flame away while refueling and away from the location where gasoline is stored. Never refuel indoors where gasoline fumes may reach flames and/or sparks.
- Allow this product to cool for at least 2 minutes before removing the fuel tank cap. Loosen the cap slowly to relieve pressure in the fuel tank. Avoid spilling fuel.
- Do not fill the fuel tank above the upper limit line. Gasoline may expand during operation. Do not fill to the top of the tank.
- Always check for spilled gasoline and immediately wipe it up before starting this product.
- Empty the fuel tank before storing or transporting this product.
- Always handle fuel outdoors.
- Before transporting, turn the fuel valve to the “OFF” position and disconnect the spark plug.

⚠ DANGER

High Temperatures: This product produces heat when in operation. Temperatures near the exhaust can exceed 150 Degrees Fahrenheit (65 Degrees Celsius).

- Do not touch hot surfaces. Observe all warning placards on this product denoting hot surfaces.
- Allow this product to cool for several minutes after use before touching the engine, muffler or other areas that are hot during operation and before storing indoors.
- Hot exhaust may ignite some materials. Keep flammable materials away from this product.
- Keep at least several feet of clearance on all sides of this product during operation. Do not enclose this product in any structure.

In addition to the previously described safety information, familiarize yourself with all safety and hazard placards on this product.

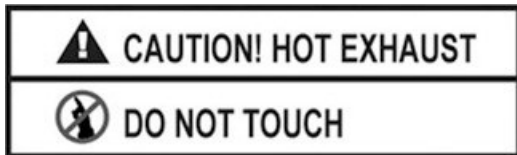
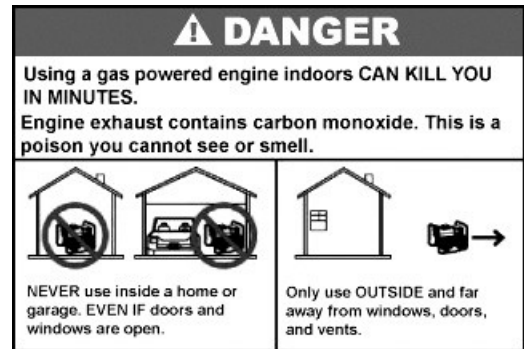
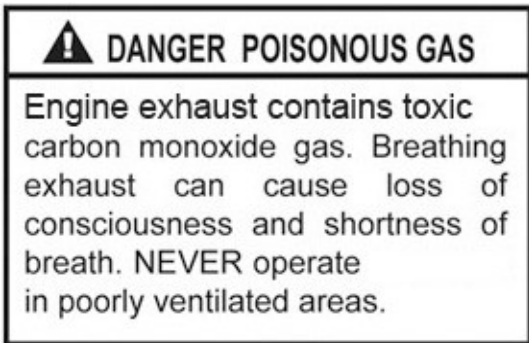

⚠ WARNING

READ AND UNDERSTAND ALL INSTRUCTIONS. Failure to follow all instructions may result in serious burns, fire and/or serious personal injury.

WHAT YOU NEED TO KNOW ABOUT SAFETY INSTRUCTIONS

The warning and safety instructions appearing in this manual are not meant to cover all possible conditions and situations that may occur. Common sense, caution and care must be exercised when operating or cleaning tools and equipment. Always contact your dealer, distributor, service agent or manufacturer about problems or conditions you do not understand before operating the product.

GENERAL PRODUCT SPECIFICATIONS

PACKAGE CONTENTS

1-Inch Water Pump

SPECIFICATIONS

Engine 2-Stroke
 Engine Type 2-Cycle
 Engine Displacement 43cc
 Horsepower 1.4 HP
 Noise Level @ 7 meter 83 dB
 Runtime: 1 hour for full tank

Requires: 0.5376 ounces of 2-Cycle
 Engine oil with 26 ounces of
 gasoline

Spark Plug : Type F6TC

FEATURES

Max. Lift Head 98 Ft (30m)
 Max. Suction Head 26 Ft. (8m)
 Pump Speed 6,500
 RPM Air-Cooled, TCI Ignition
 Flow : 2,020 x 85% GPH @ 0 Lift
 1,119 x 85% GPH @ 70 Ft. Lift

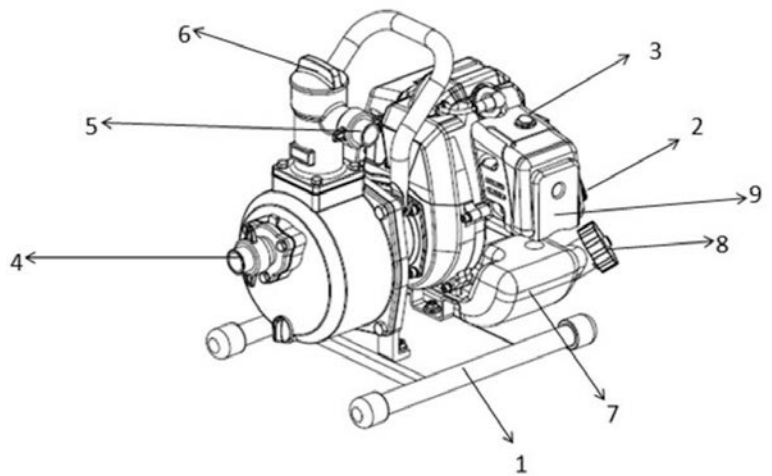

COMPONENTS

- 1) Tube Frame
- 2) Pull Start Handle
- 3) On/Off Switch
- 4) Water Inlet
- 5) Water Outlet
- 6) Priming Cap
- 7) Fuel Tank
- 8) Fuel Cap
- 9) Air Filter Assembly

ASSEMBLY

The Intake Filter prevents damaging particles from “entering” the Water Pump. Connect the Intake Filter (A) to the end of a garden hose.

Put the Gasket (D) into the hose coupling (C) and secure it to the other end of the hose. Then connect the entire assembly to the water intake side.

Place the gasket (D) into the Hose Coupling (C), and secure it to the water outlet side. Then connect the other end of Hose Coupling (C) to the hose.

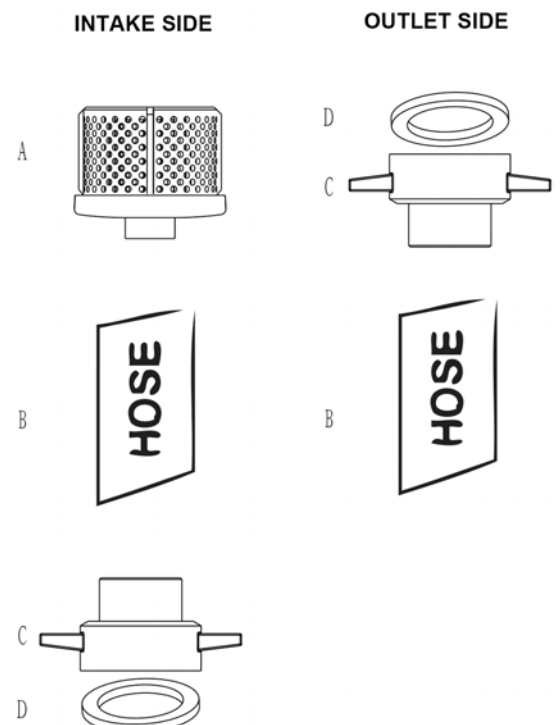

PREPARING THE WATER PUMP FOR USE

STEP 1

When new from the package, this Water Pump contains no oil or gas in the engine crankcase.

Add the correct quantity of oil / gas before operating this Water Pump for the first time. This Water Pump requires 2-cycle engine oil plus a mixture of gasoline to function.

1. Prepare Unleaded Gasoline plus 2-cycle oil for outdoor power equipment using 50:1 ratio.
2. Mix together : 0.5376 ounces of oil with 26 ounces of gasoline

STEP 2

⚠ WARNING

Gasoline and gasoline fumes are highly flammable and explosive. Handling fuel can result in serious injury or burns.

- Do not fill the fuel tank near a heat, sparks or an open flame. Keep gasoline away from appliance pilot lights, barbecues, electric appliances, power tools, etc.
- Do not overfill the fuel tank. Always check for fuel spills and immediately wipe them up. Spilled fuel is a fire hazard and causes environmental damage.

To ensure that this Water Pump runs smoothly, use only FRESH, UNLEADED GASOLINE WITH AN OCTANE RATING OF 87 OR HIGHER. Unleaded gasoline produces fewer engine and spark plug deposits and extends the life of the exhaust system.

1. Confirm that this Water Pump is on a level surface.
2. Unscrew fuel tank cap and set aside. (NOTE: Cap may be tight and difficult to unscrew.)
3. Slowly add fresh, unleaded gasoline to the fuel tank. Be careful not to fill the fuel tank above the upper limit line. The fuel tank capacity for this Water Pump is listed below. NOTE: Because gasoline can expand, do not fill the fuel tank to the very top.
4. Securely tighten the fuel tank cap and immediately wipe up any spilled gasoline with a dry cloth.

STARTING THE WATER PUMP

1. Only use outdoors.
2. Confirm that 2-Cycle Oil/Gas has been properly added.
3. Prime the water pump (see page 8)
4. Move the choke lever to the “closed” position.
5. Set the engine switch to the “on” position. (Figure 2)
6. Press the Primer Button (Figure 3) six times.
7. Slowly pull on the recoil starter handle until a slight resistance is felt. Then pull briskly to start the engine.
8. Gently return the cord into the Water Pump to avoid damage to the starter or housing. Never allow the cord to snap back.
9. If the engine fails to start, repeat step 6. NOTE: After repeated attempts to start the engine, consult the troubleshooting guide before attempting again. If problems persist, **call 1-866-460-9436, Monday - Friday, 8 AM - 4 PM Central Time.**
10. Once the engine has started and runs for about a minute, move the choke lever approximately half way towards the “open” position. Wait an additional 30 seconds and then move the choke lever completely over to the “open” position.
11. Allow this Water Pump to run for several minutes before beginning the project. After pump is running smoothly, adjust the throttle of the pump. Choose the appropriate speed to maintain good fuel consumption. (See Figure 3.1, 3.2, and 3.3)



Figure 2



Figure 3



(Figure 3.1)

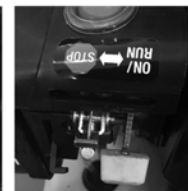

(Figure 3.2)



(Figure 3.3)

BREAK-IN PERIOD

Breaking in an engine of any size is important to the life of the engine. The first twenty hours of operation is considered the break-in period for this Water Pump. For best results and an engine with fewer problems, it is suggested that you:

- Avoid heavy loads during the first twenty hours.
- Not run the engine at its highest speeds for extended periods.

OPERATION

⚠ WARNING

Wear eye and hearing protection when using this Water Pump.

CAUTION

Moisture can condense in a unit, so it is extremely important to drain the tank after each use. If left in the tank, moisture could cause rust and weaken the tank.

PRIMING THE WATER PUMP

Be certain that hoses have been attached to BOTH the Intake and Outlet joints.

The water pump is ready to be primed before use. Priming forces air out of the pump allowing it to pump water more efficiently.

1. Place the Water Pump on a solid, level surface as close to the water source as possible.
2. Remove the Priming Plug (A, Figure 4)
3. Fill the water pump with water by filing through the opening.
4. Replace the Priming Plug.
5. Start the engine.
6. The Water Pump is now primed and ready for use.

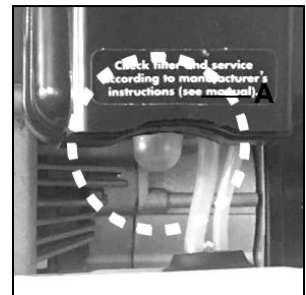
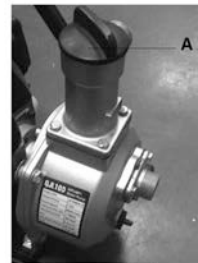

Figure 3



(A, Figure 4)

MAINTENANCE

Routine maintenance of this Water Pump is essential for safe, economical, and trouble-free operation. It will help prolong the life of this Water Pump as well as help reduce air pollution.

⚠ WARNING

Improper maintenance and/or failure to correct any problems prior to operating this Water Pump can cause a malfunction, which could cause death or serious injury. Always follow the inspection and maintenance recommendations and schedules in this manual.

During colder temperatures, icing may build in the carburetor. If this develops, the engine may run rough, lose power and possibly stall. This temporary condition can be overcome by deflecting some of the hot air from the engine over the carburetor area.

Completely drain the Water Pump before placing it in storage.

AIR FILTER MAINTENANCE

⚠ WARNING

Wear ANSI-approved safety gear, including safety goggles and heavy-duty work gloves when servicing this Water Pump.

This Water Pump will work more efficiently with a clean air filter. The air filter should be checked every 25 hours of use, regardless of workload, and replaced every 100 hours regardless of workload.

To clean or replace the air filter:

1. Remove the air filter cover, which is held in place by a nut and is located on top of the Water Pump. (A, Figure 5)
2. Remove the air filter.
3. If the air filter is paper, use a vacuum to remove any trapped dirt. If this doesn't work, replace with a new filter.
4. If the air filter is foam, wash the filter in warm water and a mild detergent before rinsing thoroughly.
5. Squeeze out excess moisture and dry completely.
6. Briefly soak the filter in lightweight oil, squeezing out the excess, before replacing it in the Water Pump.



Figure 5

SPARK PLUG MAINTENANCE

This Water Pump will work more efficiently with a properly functioning spark plug. The spark plug should be replaced every 100 hours of use.

To check or replace the spark plug:

1. Disconnect the spark plug wire from the spark plug.
2. Clean around the spark plug using a wire brush before removing the plug using a spark plug wrench.
3. Check the spark plug for foreign substances. If moisture is present, wipe it off using a clean shop towel. If there are deposits present (A, Figure 6), use a fine grit sand paper to remove them. If there is structural damage to the spark plug, replace it with a new one (B, Figure 6).
4. When installing the new plug, replace it with a Type F6TC and set the gap to 0.60 – 0.80mm.

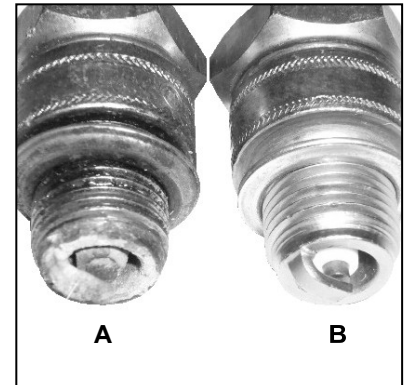

Figure 6

STORAGE

CAUTION

Do not store fuel/oil mix for more than 3 months.
Never place any type of storage cover on this Water Pump while it is still hot.
Prior to restarting, thaw out any possible ice from the Water Pump.

The life of this Water Pump can be extended through proper maintenance procedures. When placing this Water Pump in storage for over fourteen days, following these procedures will increase its service life.

1. Allow engine to cool completely, and then clean the Water Pump using a cloth and mild detergent.
2. Remove any fuel from the fuel tank.
3. Disconnect the spark plug wire and remove the spark plug.
4. Pour one teaspoon of engine oil into spark plug hole and replace the spark plug but do not reconnect the spark plug wire.
5. Gently, but firmly pull the starter cord to distribute the oil inside the cylinder, stopping when you feel resistance.
6. Remove all water from the primer water tank.
7. Wipe all metal components with an oil-soaked rag to inhibit rust and corrosion.
8. When the engine has cooled completely, cover the Water Pump with a tarp and store in a cool, dry, well-ventilated space out of the reach of children.

PARTS DIAGRAM / PARTS LIST

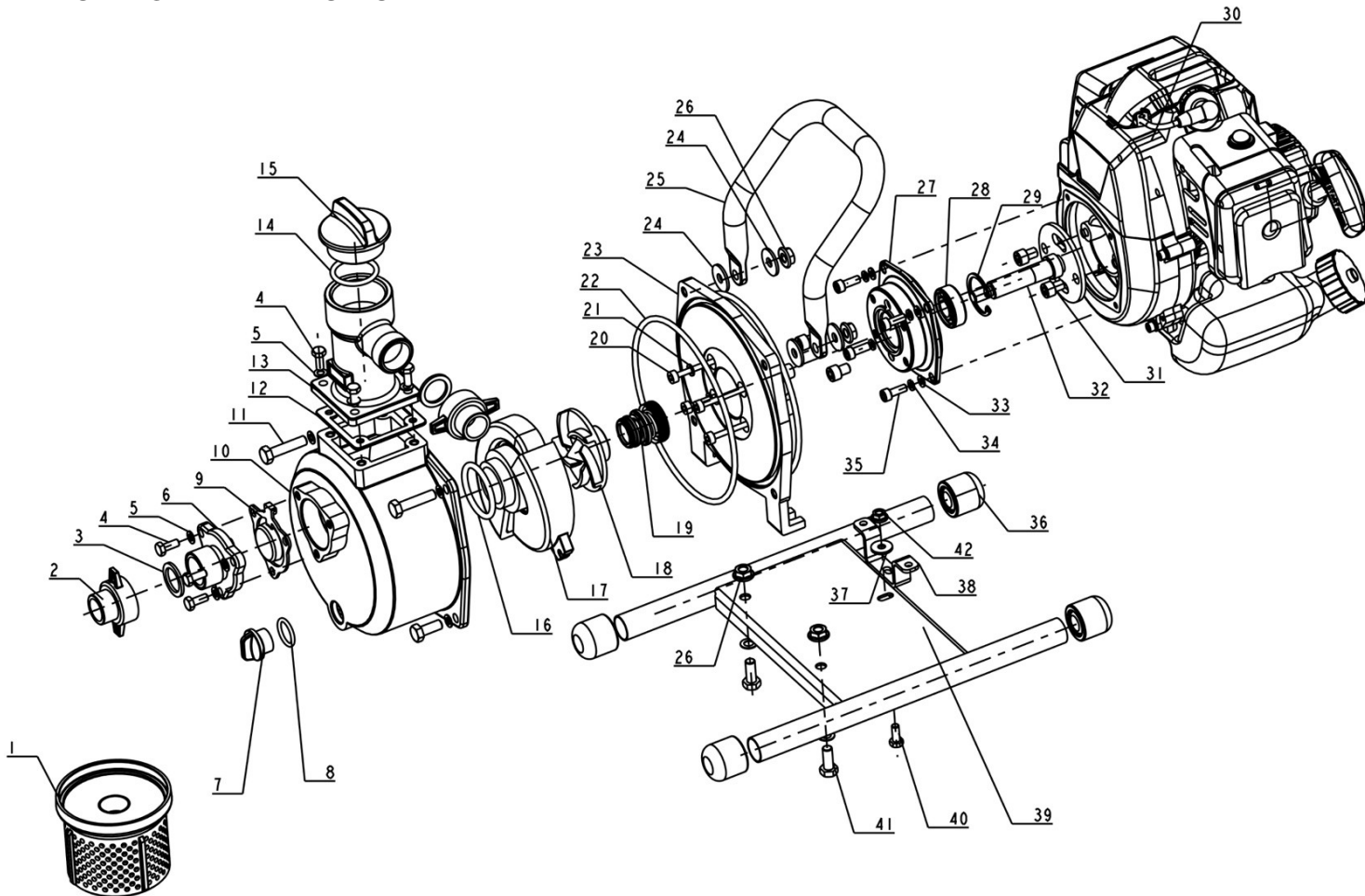

No	Part No	Description	Qty
1	QJL10D.06B	Filter Assy	1
2	QJL10.01-02B	Fastening piece	2
3	QJL10.01-05	Coupling seal washer,	2
4	B01240602067	Hex bolt,M6*20	7
5	B07010006006	Flat washer,Ø6	7
6	QJL10.02-01	Water inlet port	1
7	QJL10.01-06	Plug	1
8	QJL10.01-07	Seal ring, plug	1
9	QJL10.02.01	Sea ring, water inlet port	1
10	QJL10.03-01	Casing	1
11	B01240803526	Hex bolt,M8*35	2
12	QJL10.01-04	Seal ring, water outlet port	1
13	QJL10D.03-01	Water outlet port	1
14	QJL10D.03-03	O Ring,outer diameter:Ø41*Ø4	1
15	QJL10D.03-02	End cap	1
16	QJL10.04-02	Seal ring, guide vane	1
17	QJL10.04-01	Guide vane	1
18	QJL10-03	Impeller	1
19	QJL10.05	Mechanical seal Assy	1
20	B02040605067	Inner hex screw,M6*50	4
21	B07010005020	Aluminum spacer,Ø6Ø10Ø1	4

No	Part No	Description	Qty
22	QJL10-02	Sealing Washer, casing cover	1
23	QJL10-01	Casing cover	1
24	B07020008046	Big flat washer,Ø8Ø24*2	4
25	QJL10D.02-03	Handle	1
26	B04280800046	Nut, M8	4
27	QJL10D.01-02	Connecting Flange	1
28	B12016020200	Bearing,Ø35	1
29	B08060003511	Circlip,Ø35	1
30	101040080001000	Engine Assy,JF1E40F-12BC	1
31	B02040802067	Inner hex screw,M8*20	2
32	QJL10D.01-01	Connecting shaft	1
33	B07010006047	Flat washer,Ø6	4
34	B07000006047	Spring washer,Ø6	4
35	B02040601667	Inner hex screw, M6*16	4
36	QJ2500SP.05-05	Damping bushing	4
37	B07021500246	Big flat washer,Ø6*Ø18*1.5	1
38	QJL10D.02-02	Supporting bracket, engine	1
39	QJL10D.02-01	Frame	1
40	B01310601626	Flange bolt, M6*16	1
41	B01240802026	Hex Bolt, M8*20	2
42	B04280600046	Nut, M6	1

PARTS DIAGRAM / PARTS LIST

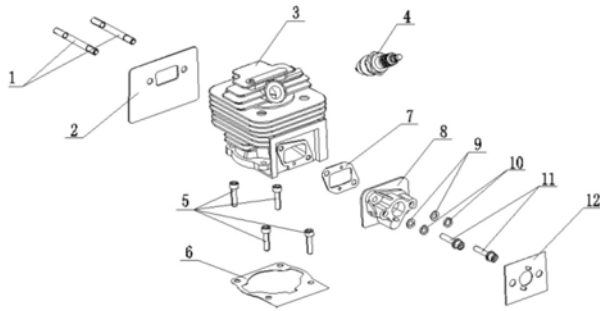

Cylinder Ass'y

No.	Parts NO.	Parts Code	Name	Q
1	GB/T900	B03070606381	Stud Bolt,AM6X63	2
2	QJ1E40F-5.1-6	32050104001000	Gasket, Muffler	1
3	QJ1E40F-5.1-3	32030104001000	Cylinder	1
4	QJ1E40F-5.1.3	22030404001000	Spark Plug	1
5	GB/T70.1	B02040502061	Bolt,M5×20	4
6	QJ1E40F-5.1-4	32040104001001	Gasket, Cylinder	1
7	QJ1E40F-5.1-2	32020104001001	Gasket, Cylinder Intake	1
8	QJ1E40F-5.1.1	22020104001000	Isolator Block, Carburetor	1
9	GB/T95-2002	B07010005041	Washer, 5	2
10	GB/T93-1987	B07000005041	Spring Washer, 5	2
11	GB/T70.1	B02040502561	Bolt,M5×25	2
12	QJ1E40F-5.1-1	32010104001001	Gasket, Carburetor	1

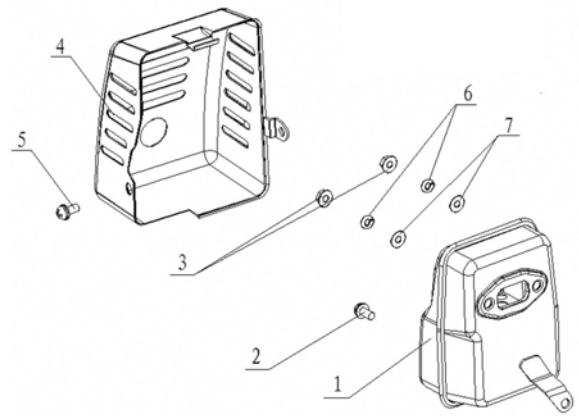

Muffler Ass'y

No.	Parts NO.	Parts Code	Name	Q
1	JF1E40F-11.5.1D	27060104009000	Muffler Ass'y	1
2	GB/T818	B02210501021	Bolt, M5×10	1
3	GB/T6177.1	B04280600026	Nut,M6	2
4	JF1E40F-11.5.1-1-1	37090104001000	Muffler Cover	1
5	GB9074.4	B13080501221	Bolt Assy, M5×12	1
6	GB/T93-1987	B07000006041	Spring Washer, 6	2
7	GB/T95-2002	B07010006041	Washer, 6	2

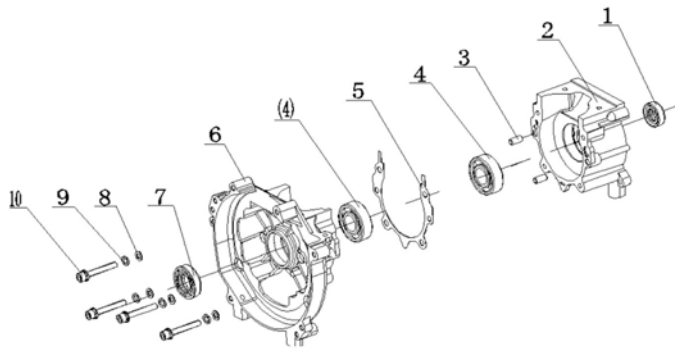

Crankcase Ass'y

No.	Parts NO.	Parts Code	Name	Q
1	QJ1E32QDA-2.2-5	31050101001000	Oil Seal,12×22×7	1
2	WJF1E40F-7.2-4	31100104001000	Right Crankcase	1
3	GB/T119.1	B09030501200	Pin,B5×12	2
4	GB/T276	B12016020200	Bearing,6202	2
5	QJ1E40F-5.2-3	31030104001000	Gasket, Crankcase	1
6	WJF1E40F-7.2-2	31090104001000	Left Crankcase	1
7	QJ1E40F-5.2-1	31010104001000	Oil Seal,15×30×7	1
8	GB/T95-2002	B07010005041	Washer, 5	4
9	GB/T93-1987	B07000005041	Spring Washer, 5	4
10	GB/T70.1	B02040503561	Bolt,M5×35	4

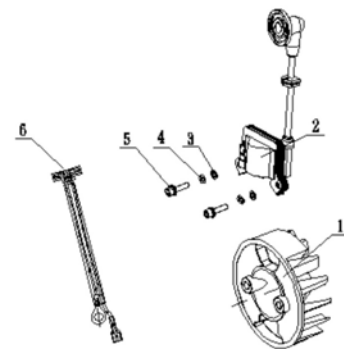

Ignition System Ass'y

No.	Parts NO.	Parts Code	Name	Q
1	QJ1E40F-5.6.3	28050104001000	Rotor Ass'y	1
2	JF1E40F-12.6.1	28080104001000	Ignition Coil	1
3	GB/T95	B07010005041	Washer, 5	2
4	GB/T93	B07000005041	Spring Washer, 5	2
5	GB/T70.1	B02040502061	Bolt, M5×20	2
6	JF1E40F-12.6.2B	28090104001000	Bumpingout Wire Assy	1

PARTS DIAGRAM / PARTS LIST

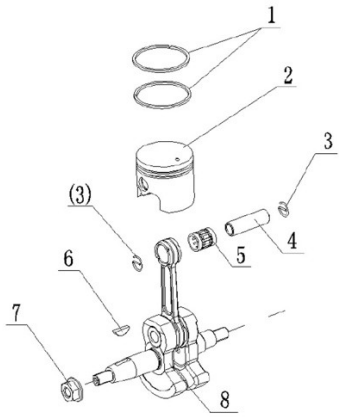

Crankshaft Connecting Rod Piston Ass'y

No.	Parts NO.	Parts Code	Name	Q
1	QJ1E40F-5.3-3	34030104001000	Piston Ring	2
2	QJ1E40F-5.3.1	24020104001000	Piston	1
3	QJ1E40F-5.3-4	34040104001000	Circlip,Piston Pin	2
4	QJ1E40F-5.3-2	34020104001000	Piston Pin	1
5	QJ1E40F-5.3-1	34010104001000	Needle Bearing,K10×13×15	1
6	GB/T1099	B11210305013	Key,3×5×13	1
7	GB/T6177.1	B04280800025	Nut,M8	1
8	QJ1E40F-5A.3.2	24040104001000	Crankshaft Connecting Rod Ass'y	1

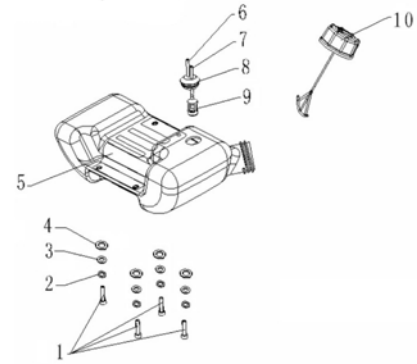

Fuel Tank Ass'y

No.	Parts NO.	Parts Code	Name	Q
1	GB/T70.1	B02040501861	Bolt , M5×18	4
2	GB/T93	B07000005041	Spring Washer, 5	4
3	GB/T95	B07010005041	Washer, 5	4
4	GB/T96.2	B07020005046	Washer, Φ5×14×1	4
5	JF1E40F-12.11.1D	27080104011000	Fuel Tank	1
6	JF1E40F-12.11-2B	37110104001001	Fuel Line 1	1
7	JF1E40F-12.11-1B	37100104001001	Fuel Line 2	1
8	JF1E38QCA.8-9	37120104001000	Seal, Fuel Lines	1
9	JF1E40F-9.12.3	27100104001000	Fuel Filter	1
10	JF1E40F-12.11.2	27090104001000	Fuel Cap	1

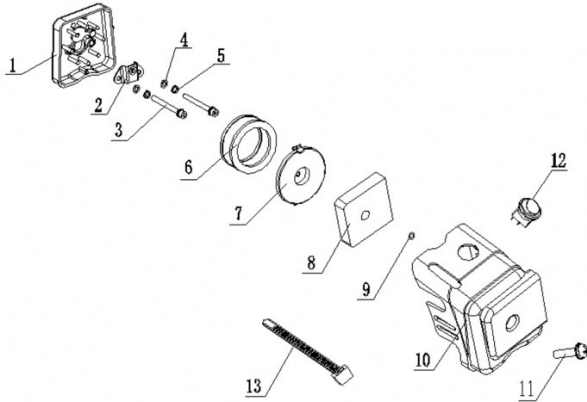

Air Filter Ass'y

No.	Parts NO.	Parts Code	Name	Q
1	QJ1E40F-5.4.4	27050104001000	Seat,Air Filter	1
2	QJ1E40F-5.4.2	27040104001000	Bracket, Air Filter Mounting	1
3	GB/T70.1	B02040505561	Bolt, M5×55	2
4	GB/T95	B07010005041	Washer, 5	2
5	GB/T93	B07000005041	Spring Washer, 5	2
6	JF1E40F-12.4.5	27020104011000	Air Filter Element,Assy	1
7	QJ1E40F-5.4.3	37030104001000	Mounting Plate, Air Filter	1
8	JF1E40F-12.4.4	37140104001000	Foam Element, Pre-Filter	1
9	GB/T3452.1	B220100315A0	O-ring,3.15×1.8	1
10	JF1E40F-11.4-1	37130104001000	Cover, Air Filter	1
11	GB9074.4	B13080502021	Bolt Assy, M5×20	1
12	JF1E40F-11.6-1	28070104001001	Switch (With Waterproof Cap)	1
13	1E38QCA-5.9.3-17	38050113001000	Tie	1

PARTS DIAGRAM / PARTS LIST

Carburetor Ass'y

No.	Parts NO.	Parts Code	Name	Q
1	JF1E40F-12B.7.1	27010104008000	Carburetor Ass'y	1

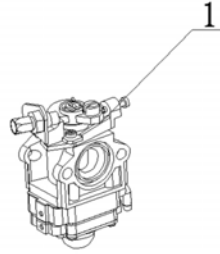

Air Cooling Ass'y

No.	Parts NO.	Parts Code	Name	Q
1	GB/T9074.4	B13080501621	Bolt Assy, M5×16	1
2	JF1E40F-11.8-1B	36010104009750	Cowling, Cylinder	1
3	QJ1E40F-5.8-2	36020104001000	Gap Cowling	1
4	GB/T9074.4	B13080502321	Bolt Assy, M5×23	1

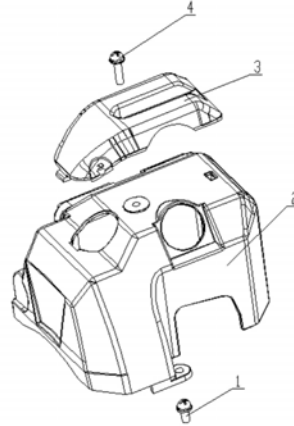

Engine Starter Ass'y

No.	Parts NO.	Parts Code	Name	Q
1	GB/T9074.4	B13080502021	Bolt Assy, M5×20	4
2	JF1E40F-12.9.3	26040104011000	Engine Starter Ass'y	1
3	QJ1E38F.4.3-3	36090104001000	Gasket, Recoil Starter	1
4	QJ1E38F.4-2	36030104001000	Nut	1
5	JF1E40F-12.9.2	26030104011000	Starting Jaw Assy	1

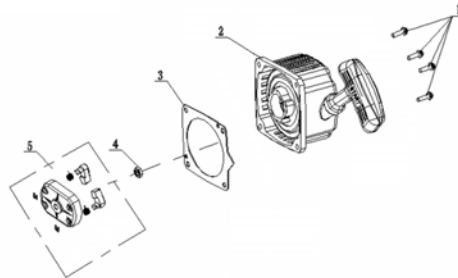

Magneto Cover Ass'y

No.	Parts NO.	Parts Code	Name	Q
1	GB/T119.1	B09030401000	Pin, B4×10	2
2	QJ1E40F-5.10-1	31070104001000	Magneto Cover	1
3	GB/T9074.4	B13080502321	Bolt Assy, M5×23	4

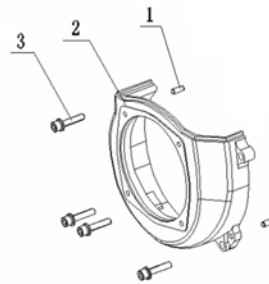

202010