

ITEM # MT43CC

2-CYCLE EARTH CULTIVATOR INSTRUCTION MANUAL



READ ALL INSTRUCTIONS AND WARNINGS BEFORE USING THIS PRODUCT.

This manual provides important information on proper operation & maintenance. Every effort has been made to ensure the accuracy of this manual. These instructions are not meant to cover every possible condition and situation that may occur. **We reserve the right to change this product at any time without prior notice.**

IF THERE IS ANY QUESTION ABOUT A CONDITION BEING SAFE OR UNSAFE, DO NOT OPERATE THIS PRODUCT!

Questions? Call Customer Service!

If you experience a problem, have questions or need parts for this product, call Customer Service at 1-866-460-9436, Monday-Friday, 8 AM - 4 PM Central Time. A copy of the sales receipt is required.

FOR CONSUMER USE ONLY – NOT FOR PROFESSIONAL USE.

KEEP THIS MANUAL, SALES RECEIPT & APPLICABLE WARRANTY FOR FUTURE REFERENCE.

Read this entire manual before installation and use. We reserve the right to change, alter or improve the product and this document at any time without prior notice.

CONTENTS

Specifications	3
Warnings and Safety Precautions	4-7
Unpacking and Assembly	7
Operating Your Cultivator	8
Maintenance	11
Transporting and Storage	13
Troubleshooting	14
Parts Diagrams & Parts Lists	15

2 YEAR LIMITED EMISSION-RELATED WARRANTY

THIS ENGINE MEETS U.S. EPA EMISSION STANDARDS UNDER 40 CFR 1054.625 .The emission-related limited warranty is valid for two (2) years. Keep the purchase receipt and mail in the product registration card for proof of purchase. Buffalo Corp limits emission

n-related warranty repairs to authorized service centers for owners located within 100 miles of an authorized service center. For owners located more than 100 miles from an authorized service center, Buffalo Corp will, in its sole discretion, either pay for shipping costs to and from an authorized service center, provide for a service technician to come to the owner to make the warranty repair, or pay for the repair to be made at a local non-authorized service center. The provisions of this paragraph apply only for the contiguous states, excluding the states with high-altitude areas identified in 40 CFR part 1068, Appendix III.

To exercise this warranty, DO NOT RETURN TO RETAILER. Instead, call Customer Service toll free at 1-866-460-9436 (email address info@buffalotools.com) and you will be instructed on where to take the engine for warranty service. Take the product and proof of purchase (your receipt) to the repair facility recommended by the Customer Service Representative. The warranty does not extend to products damaged or affected by fuel contamination, accidents, neglect, misuse, unauthorized alterations, use in an application for which the product was not designed and any other modifications or abuse.

1 YEAR LIMITED WARRANTY (30 Day Limited Warranty for Commercial and Rental Purpose)

This product is warranted to be free from defects in materials and workmanship for a period of 1 YEAR from date of original purchase. Buffalo Corp. is not liable for any indirect, incidental or consequential damages from the sale or use of this product. Any implied warranties are limited to 1 YEAR as stated, or as otherwise stated, in this written limited warranty. Some states do not allow the exclusion or limitation of incidental or consequential damages. Some states do not allow limitation on the length of an implied warranty. Buffalo Corp will repair or replace, at its discretion, any part that is proven to be defective in materials or workmanship under normal use during the 1 YEAR warranty period. Warranty repairs or replacements will be made without charge for parts or labor. Parts replaced during warranty repairs will be considered as part of the original product and will have the same warranty period as the original product. This warranty gives you specific legal rights, and you may have other rights that vary state to state

REGISTRATION

Record your model number and serial number in the space provided for easy reference. Fill out and mail the registration card located in your parts packet. Warranty is valid only if the completed registration card is received by within 30 days of purchase.

Item Number	
Serial Number	
Engine Serial Number	
Date of Purchase	
Place of Purchase	

INTRODUCTION

OWNER'S RESPONSIBILITY

Accurate assembly and safe and effective use of the cultivator is the owner's responsibility.

- Read and follow all safety instructions.
- Carefully follow all assembly instructions.
- Maintain the cultivator according to directions and schedule included in this operator's manual.
- Ensure that anyone who uses the cultivator is familiar with all controls and safety precautions.

SPECIFICATIONS

ENGINE DISPLACEMENT	43cc
FUEL TANK CAPACITY	28.75 ounces
GAS/OIL RATIO	50:1 (2.6 ounces oil per gallon of gasoline)
OIL TYPE	2 CYCLE ENGINE OIL
GAS TYPE	UNLEADED REGULAR GAS
SPARK PLUG	L6
SPARK PLUG GAP	0.6-0.8mm(0.027-0.031 in)
TRANSMISSION	GEAR DRIVE
GEAR RATIO	32:1
TILLING WIDTH	7 inch minimum - 10 inch maximum
TILLING DEPTH	Up to 5"
TINE SPEED	250 RPM
WHEEL SIZE	1.5 x 7.0 inch diameter

GENERAL SAFETY RULES

SPECIAL MESSAGES

Your manual contains special messages to bring attention to potential safety concerns, machine damage as well as helpful operating and servicing information. Please read all the information carefully to avoid injury and machine damage.

 CAUTION
AVOID INJURY! THIS SYMBOL AND TEXT HIGHLIGHT POTENTIAL HAZARDS OR DEATH TO THE OPERATOR OR BYSTANDERS THAT MAY OCCUR IF THE HAZARDS OR PROCEDURES ARE IGNORED.

IMPORTANT
AVOID DAMAGE! THIS TEXT IS USED TO TELL THE OPERATOR OF ACTIONS OR CONDITIONS THAT MIGHT RESULT IN DAMAGE TO THE MACHINE.

NOTE: *General information is given throughout the manual that may help the operator in the operation or service of the machine.*

IMPORTANT SAFETY PRECAUTIONS

Please read this section carefully. Operate the cultivator according to the safety instructions and recommendations outlined here and inserted throughout the text. Anyone

who uses this cultivator must read the instructions and be familiar with the controls.



This symbol points out important safety instructions which if not followed could endanger your personal safety. Read and follow all instructions in this manual before attempting to operate this equipment.

- Do not transport the cultivator from one place to another with the engine running.
- The tines of the cultivator should not rotate when the engine is idling. If it does rotate when engine is idling, contact the distributor for instructions.
- Dress appropriately when operating the cultivator. Always wear sturdy footwear (e.g., steel-toed boots). Never wear sandals, sneakers, or open shoes, and never operate the cultivator with bare feet. Do not wear loose clothing that might get caught in moving parts. Always wear ANSI-approved safety glasses for eye protection.
- Always keep hands, feet, hair and loose clothing away from any moving parts on engine and cultivator.
- Always wear a protective hearing device.
- Do not allow children to operate this cultivator. Do not allow adults to operate the cultivator without proper instruction.
- Do not operate any power equipment under the influence of alcohol or drugs.
- Keep all screws, nuts and bolts tight.
- Engine should be turned off and cool, spark plug wire must be removed from spark plug before any repairs or adjustments are attempted.
- Temperature of muffler and nearby areas may exceed 150° F (65° C). Avoid these areas.
- Never run engine indoors or in an enclosed area. Engine exhaust contains carbon monoxide, an odorless and deadly gas.
- Carefully inspect the area to be cultivated, and remove all foreign objects. Do not cultivate above underground utilities, including water lines, gas lines, electric cables, or pipes. Do not operate the cultivator in soil with large rocks and foreign objects which can damage the equipment.
- If an object becomes lodged in the tines, turn engine off, remove the wire from the spark plug and secure, allow to cool before attempting to remove the foreign object.

ENGINE SAFETY PRECAUTIONS



Warning Carbon Monoxide Poisoning

All engines contain carbon monoxide in their exhaust. Carbon monoxide is a deadly, colorless, tasteless, odorless gas which may be present even if you do not smell or see any engine exhaust. Levels of carbon monoxide, which can be deadly, can be present for days in an enclosed area that has poor ventilation. Any level of carbon monoxide, if inhaled, can cause headaches, drowsiness, nausea, dizziness, confusion and eventually death. If you experience any of these symptoms, seek fresh air and medical attention immediately.

Preventing Carbon Monoxide Poisoning

Never run engine indoors.

- Never try to ventilate engine exhaust indoors. Carbon monoxide can reach dangerous levels very quickly.
- Never run engine outdoors where exhaust fumes may be pulled into a building.
- Never run engine outdoors in a poorly ventilated area where the exhaust fumes may be trapped and not easily taken away. (Examples include: in a large hole or areas where hills surround your working area.)
- Never run engine in an enclosed or partially enclosed area. (Examples include: buildings that are enclosed on one or more sides, under tents, car ports or basements.)
- Always run the engine with the exhaust and muffler pointed in the direction away from the operator.
- Never point the exhaust muffler towards anyone. People should always be many feet away from the operation of the engine and its attachments.

Gasoline Fires and Handling Fuel Safely

Fuel and fuel vapors are highly flammable. Never use fuel where a spark or flame may be present. Never use fuel where a potential source of ignition could occur. (Examples include: hot water or space heaters, clothes dryer, electric motors, etc.) Keep flames and sparks away from engine and fuel to prevent fires. Fuel fires spread very quickly and are highly explosive.

Prevention of Gasoline Fires

- Never fill your fuel tank indoors. (Examples include: basement, garage, barn, shed, house, porch, etc.)

Always fill fuel tank outside in a well-ventilated area.

- Never remove the fuel cap or add fuel with the engine running. Stop engine and allow to cool before filling.
- Never drain fuel from engine in an enclosed area.
- Always wipe up excess (spilled) fuel from engine before starting. Clean up spilled fuel immediately.
- Allow spilled fuel to dry, after wiping and before starting.
- Allow fuel fumes/vapors to escape from the area before starting engine.
- Test the fuel cap for proper installation before starting and using engine.
- Always run the engine with fuel cap properly installed on the engine.
- Never smoke while refilling engine fuel tank.

- Prevent fire and explosion caused by static electric discharge. Use only nonmetal, portable fuel containers approved by the Underwriter’s Laboratory (U.L.) or the American Society for Testing & Materials (ASTM).
- Do not store engine with fuel in fuel tank indoors. Fuel and fuel vapors are highly explosive.
- During storage, screw down gas cap vent screw tightly.
- Never pour fuel from engine fuel tank.
- Never siphon fuel by mouth to drain fuel tank.
- Always have an adult fill the fuel tank.
- Never allow an adult or anyone under the influence of drugs or alcohol to fill engine.
- Never allow children to fill the engine.
- The clutch will transfer maximum power after about two hours of normal operation. During this break-in period clutch slippage may occur. The clutch should be kept free of oil or other moisture for efficient operation.

BURNS AND FIRES

The muffler, muffler guard and other parts of the engine become extremely hot during the operation of the engine. These parts remain extremely hot after the engine has stopped. Do not touch.

Prevention of Burns and Fires

- Never remove the muffler guard from the engine.
- Never touch the muffler guard because it is extremely hot and will cause severe burns.
- Never the engine that becomes hot after operation.
- Always keep materials and debris away from muffler guard and other hot parts of the engine to avoid fires.

This engine is designed to operate using a catalytic converter which contributes to the engine’s compliance with the EPA.

Steps for Working on Engine or Cultivator

1. Turn off engine switch.
2. Disconnect the spark plug wire from the spark plug.
3. Securely place the disconnected spark plug wire away from the spark plug and any metal parts. This must always be done or arcing may occur between spark plug wire and metal parts.
4. Replace or repair the part on the engine or cultivator.
5. Check all parts that were repaired, or removed during repair, that they are secure and fit correctly.

NOTE: All repair parts must come from factory.

6. Replace spark plug wire.



CAUTION

HOT GASES ARE A NORMAL BY-PRODUCT OF A

FUNCTIONING CATALYTIC CONVERTER. FOLLOW ALL SAFETY INSTRUCTIONS TO PREVENT BURNS AND FIRES.

DO NOT ALTER/MODIFY ENGINE:

NEVER ALTER OR MODIFY THE ENGINE FROM THE FACTORY. SERIOUS INJURY OR DEATH MAY OCCUR IF ENGINE IS MODIFIED OR ALTERED.

WHEN WORKING ON OR REPLACING PARTS FOR THE ENGINE OR CULTIVATOR YOU MUST ALWAYS DISCONNECT SPARK PLUG WIRE FROM THE SPARK PLUG AND

SAFETY DECALS

Reading this manual and the safety instructions it contains will provide you with the necessary basic knowledge to operate this equipment safely and effectively. We have placed a safety decal on the cultivator to remind you of some of this important information while you are operating the unit.

Familiarize yourself with the location and content of the safety messages you will see as you perform normal cultivating operations. Please review this decal (above). If you have any questions regarding its meaning or how to comply with these instructions, reread the complete safety instruction text in this manual, or contact your local dealer.

Should this decal become unreadable because of being worn, faded, or otherwise damaged during the use of your cultivator, please use the part number information provided to order a replacement label from customer service. These decals are easily applied, and will act as a constant visual reminder to you, and others who may use the equipment, to follow the safety instructions necessary for safe, effective operation of your cultivator.

WARNING : KEEP AWAY FROM ROTATING TINES

Rotating tines will cause injury. Read operator manual. Know the location and function of all controls. Wear safety eye glasses and ear protection. Never allow children or uninstructed adults to operate machine. Shut off engine before manually unclogging tines or making repairs. Keep bystanders away from machine. Keep away from rotating parts. Use caution when reversing or pulling the machine towards you. Failure to follow warning can result in serious bodily injury.

UNPACKING & ASSEMBLY

UNPACK CULTIVATOR

1. Carefully lift the cultivator out of the box, remove any packing material and cut any ties holding the handlebar pieces to the cultivator assembly.

ASSEMBLY

1. Stand the cultivator assembly upright with tines and wheels on a level surface. Wheels should be set in the lowest position. **DO NOT** place the cultivator on a high surface where it can fall and cause property damage or personal injury.
2. Using two bolts and two T-knobs, assemble the middle handle to the lower handle that is already attached to the cultivator assembly. **DO NOT** overtighten the tee handle nuts.
3. Attach the upper right and left handles to the middle handle using the two remaining bolts and T-knobs. **DO NOT** overtighten the tee handle nuts.
4. The drag stake is shipped with point facing upwards. Before using, remove detent pin and turn the drag stake around so the point is directed in the downward position facing towards the tines. Re-insert detent pin.
5. Secure the throttle cable to the handle with Five retaining clips already mounted to the handle.

SPECIFICATIONS

ENGINE DISPLACEMENT	43cc
FUEL TANK CAPACITY	28.75 ounces
GAS/OIL RATIO	50:1(2.6 ounces oil per gallon of gasoline)
OIL TYPE	2 CYCLE ENGINE OIL
FUEL TYPE	Minimum 87 octane gasoline with NO ethanol content

SPARK PLUG	L6
SPARK PLUG GAP	0.6-0.8mm(0.027-0.031 in)
TRANSMISSION	GEAR DRIVE
GEAR RATIO	32:1
TILLING DEPTH	Up to 5"
TINE SPEED	250 rpm
WHEEL SIZE	1.5 x 7.0 inch diameter

Two adjustable wheel height settings for cultivating, plus Low Height setting for easy transport

OPERATING YOUR CULTIVATOR PREPARING ENGINE FOR STARTING GAS AND OIL

Use a quality 2-cycle oil and use unleaded regular gas only. Run engine with a 50:1 ratio (gas/oil).

Mixing Fuel

1. Fuel must be mixed in a container outside in a well ventilated area.
2. Fill certified fuel container 1/4 full of recommended fuel.
3. Add recommended amount of 2 cycle oil.
4. Screw container cap on straight and tight.
5. Shake the container to mix fuel and oil.
6. Wipe away any spilled fuel or oil and allow to evaporate before moving or transporting.

Filling Fuel Tank

1. Shut off engine and allow engine to completely cool before refilling the fuel tank.
2. Move to a well-ventilated area, outdoors, away from flames and sparks.
3. Clean debris from area around the fuel cap.
4. Loosen fuel cap slowly. Place the cap on a clean, dry surface.
5. Carefully add fuel without spilling.
6. Do not fill gas tank completely full, allow space for fuel to expand.
7. Immediately replace fuel cap and tighten. Wipe off spilled fuel and allow to dry before starting engine.



CAUTION

NEVER STORE ENGINE WITH FUEL IN THE TANK INDOORS.

FUEL AND FUEL VAPORS ARE HIGHLY FLAMMABLE.

NEVER MIX FUEL AND OIL DIRECTLY IN ENGINE FUEL TANK. USE ONLY NON METAL, PORTABLE FUEL CONTAINERS APPROVED BY THE UNDERWRITER'S LABORATORY (U.L.) OR THE AMERICAN SOCIETY FOR TESTING & MATERIALS (ASTM). AN ADULT MUST ALWAYS HANDLE AND FILL THE ENGINE WITH FUEL.

ALWAYS HANDLE GAS IN A WELL VENTILATED AREA, OUTDOORS, AWAY FROM FLAMES OR SPARKS. DO NOT START ENGINE IF FUEL IS SPILLED. WIPE OFF

NORMAL OPERATION

1. The clutch will transfer maximum power after about two hours of normal operation. During this break-in period clutch slippage may occur. The clutch should be kept free of oil and other moisture for efficient operation.
2. Cultivate without placing excessive body weight on the unit. The cultivator operates most efficiently with the weight of the unit itself.
3. Never run engine indoors. Exhaust fumes are deadly.

STARTING AND STOPPING ENGINE

- Move engine to a well-ventilated area, outdoors, to prevent carbon monoxide poisoning.
- Move to an area away from flames or sparks, to avoid ignition of vapors if present.
- Remove all debris from air cleaner holes to ensure proper air flow.

COLD ENGINE START: Starting engine for first time or after engine has cooled off or after running out of fuel.

1. Move choke lever to **RUN** position.

NOTE: Choke must be in the RUN position when pushing or using the primer bulb.

2. Prime unit until primer hose is filled with gas.

NOTE: Allow the primer bulb to return completely to its original position between pushes.

3. Move choke lever to **CHOKE** position.

Note: Choke position is defined by moving

the choke lever as far to the Choke position as possible.

4. Push rocker switch to the **ON** position.
5. Squeeze throttle control with right hand. Grasp starter handle with left hand and pull out slowly, until it pulls slightly harder. Without letting starter handle retract, pull rope with a rapid full arm stroke. Let it return to its original position very slowly until unit fires or runs. Repeat this step every time the starter rope is pulled.



WARNING

MAKE SURE THE UNIT IS IN A STABLE POSITION BEFORE PULLING THE STARTER HANDLE.

WHEN THE UNIT STARTS TO FIRE OR RUN, RELEASE THE THROTTLE CONTROL MOMENTARILY WITH YOUR RIGHT HAND AND RETURN YOUR LEFT HAND TO THE HANDLEBAR POSITION TO MAINTAIN CONTROL AND STABILITY OF THE UNIT WITH BOTH HANDS.

Note: if engine fails to start after 5-6 pulls, push primer 1 time and pull starter rope again.

6. After engine starts running, move choke lever to **HALF CHOKE** position until unit runs smoothly.

Note: Half choke is defined when the choke lever is between CHOKE and RUN.

7. Move choke lever to **RUN** position and move throttle to desired speed.

NOTE: Run at full throttle when possible.

Do not let unit idle for extended periods of time.

8. To stop engine, push ignition switch to **OFF** position.

WARM ENGINE START:

1. Move choke lever to **CHOKE** position.

Note: Choke position is defined by moving the choke lever as far to the CHOKE position as possible.

2. Continue with Step 4 of Cold Engine Starting.

HOT ENGINE START:

1. Continue with Step 4 of Cold Engine Starting.
2. If engine does not fire, refer to Step 1 of Warm Engine Starting.

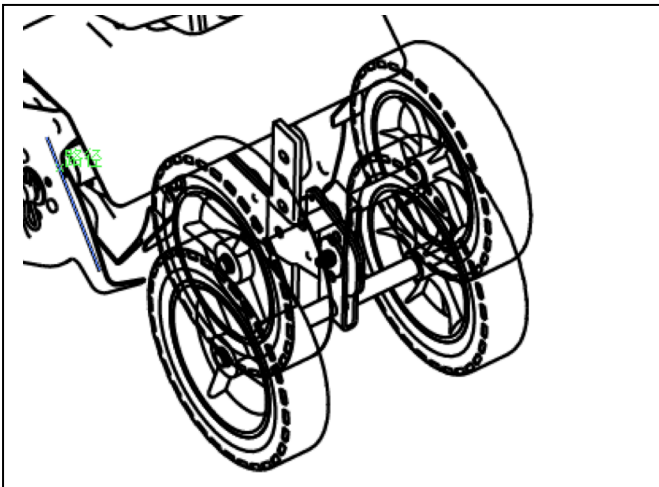

Adjusting Wheels and Drag Stake

The wheels on the cultivator can be adjusted to one of two positions. The lowest wheel position is used for transporting the cultivator across a smooth level surface while the engine is not running. The highest position is used when cultivating in soil and help stabilize the unit when cultivating ~~at different depths.~~

To adjust wheels up or down:

1. Remove the hair pin and pull out the locking pin.
2. Set the wheel up or down to the desired position, and re-insert the locking pin to secure.

To adjust the drag stake:

1. Pull the detent pin out of the drag stake mount hole.
2. Slide the stake to the desired position, aligning the hole in the stake with the holes in the support bracket. Make sure the pointed tip is directed downward.
3. Insert the detent pin through the holes to secure the drag stake.

Drag Stake

The drag stake is used to help regulate cultivating depth and control the cultivator from leaping forward during operation. Resistance to forward motion is greatest when the drag stake is set in its lowest position allowing for deeper cultivation.

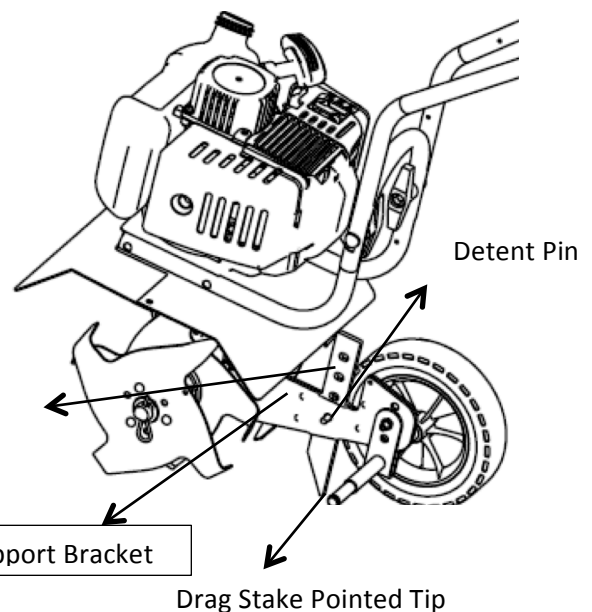

MAINTENANCE

STEPS FOR WORKING ON EQUIPMENT

1. Turn off engine switch.
2. Disconnect the spark plug wire from the spark plug.
3. Securely place the disconnected spark plug wire away from the spark plug and any metal parts. This must always be done or arcing may occur between spark plug wire and metal parts.
4. Replace or repair the part on the cultivator.
5. Check all parts that were repaired, or removed during repair, that they are secure and fit correctly.

Note: Never replace parts that are not specifically designed for the cultivator.

6. Reconnect the spark plug wire.

CULTIVATOR MAINTENANCE

1. The transmission case has grease installed at the factory. It is recommended that once a year the gear case be split by a qualified service professional and the grease level checked. Add a molythium type grease only if level of grease is below top of the gears. **DO NOT OVERFILL.**
2. Keep all screws, nuts, and bolts tight.
3. For cold weather operation, store the unit in a cool environment. Transferring the unit from a cold to a warm place can cause the build up of harmful condensation.

ENGINE MAINTENANCE

Read the maintenance schedule and observe these recommendations to extend the life of your engine.

To help you properly care for your engine, the following pages include a maintenance schedule, routine inspection procedures, and simple maintenance procedures using basic hand tools. Other service tasks that are more difficult, or require special tools, are best handled by professionals and are normally performed by a technician or other qualified mechanic.

Maintenance, replacement or repair of the emissions control devices and systems may be performed by any non-road engine repair establishment or individuals.

The maintenance schedule applies to normal operating

conditions. If you operate your engine under unusual

conditions, such as sustained high-load or high-temperature operation, or use in unusually wet or dusty conditions, consult your servicing dealer for recommendations applicable to your individual needs and use.



CAUTION

PRACTICE SAFETY AT ALL TIMES. ENGINE MUST BE TURNED OFF AND ALLOWED TO COOL, AND SPARK PLUG WIRE MUST BE DISCONNECTED BEFORE ATTEMPTING ANY MAINTENANCE OR REPAIR.

TO PREVENT ACCIDENTAL STARTING: ENGINE MUST BE TURNED OFF AND COOL, AND SPARK PLUG WIRE MUST BE REMOVED FROM SPARK PLUG BEFORE CHECKING AND ADJUSTING ENGINE OR EQUIPMENT.

TEMPERATURE OF MUFFLER AND NEARBY AREAS MAY EXCEED 150° F (65° C). AVOID THESE AREAS.

CHECK CULTIVATOR OFTEN FOR LOOSE NUTS AND BOLTS. KEEP THESE ITEMS TIGHTENED.

NEVER STORE ENGINE WITH FUEL IN THE TANK INSIDE A BUILDING. POTENTIAL SPARKS MAY BE PRESENT FOR IGNITION OF FUEL AND FUEL VAPORS.

AN ADULT MUST ALWAYS DO MAINTENANCE AND REPAIR ON ENGINE AND CULTIVATOR.

Cooling Fins

Cooling fins, air inlets & linkages must be free from any debris before each use.

Air Filter

Never run engine without air cleaner properly installed. Added wear and engine failure may occur if air cleaner is not installed on engine.

Service air cleaner every 3 months or after 20 hours of operation. Follow Figure A to remove cover and removing and replacing filter.

Clean filter daily in extremely dusty conditions.

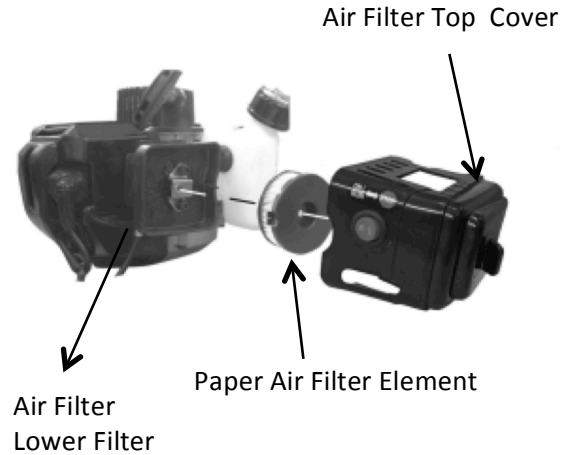

Figure A

IMPORTANT

NEVER TWIST AIR FILTERS WHEN CLEANING. ALWAYS PRESS.

Spark Plug

The recommended spark plug is a L6, which cross references to a Champion CJ8.

1. Check spark plug at the beginning of each season.
2. Disconnect the spark plug cap, and clean any debris from around the spark plug area.
3. Remove spark plug and replace if any of the following occur; pitted electrodes, burned electrodes, cracked porcelain, or deposits around electrodes.
4. After analysis, seat spark plug and tighten with spark plug wrench. Reconnect the spark plug wire.
 - Reinstall original spark plug, tighten additional 1/2 turn.
 - Installing new spark plug, adjust spark plug gap to .027-0.031in. and tighten additional 1/8 – 1/4 turn .

NOTE: Loose spark plug may overheat and damage engine. Over tightened spark plug may damage threads in the cylinder head.

Carburetor

Never tamper with factory setting of the carburetor.

To Remove Tines

1. Remove cotter pins from each end of tine shaft.
2. Slide the four tines off the shaft.

To Install Tines

1. Slide the inside tines onto each end of the tine shaft. Stamped with a “B” and the other with a “C”.
2. Slide the outside tine “A” and tine “D” onto each end of the shaft next. The tines should be installed in the correct order so that they are positioned left to right A, B, C, D, as viewed from the user’s position on the cultivator. Make sure that the hub collars on both the right and left pairs of tines face each other so that there is adequate spacing between the tine blades.
3. Insert the cotter pins into the holes at each end of the tine shaft to lock the tines into place.

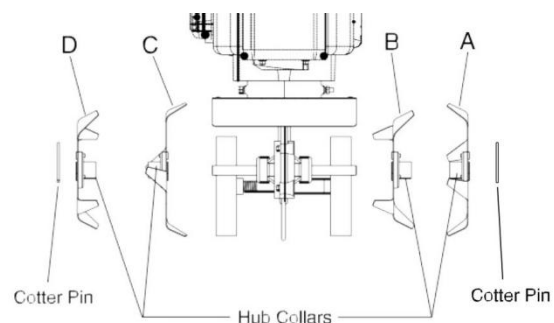

TRANSPORTING YOUR EARTH CULTIVATOR

1. After using the cultivator and before transporting it in a truck bed, screw the gas cap screw and gas cap on (clockwise) tightly. The gas cap will not leak during transporting if gas cap is tight and the screw at the top is tight. Never transport engine inside an enclosed space within a vehicle. Fuel or fuel vapors may ignite causing serious injury or death.
2. If fuel is present in the fuel tank, transport in an open vehicle in an upright position.
3. If an enclosed vehicle must be used, remove gas into an approved red fuel container. **DO NOT siphon by mouth.**
4. Run engine to use up the fuel in the carburetor and fuel tank. Always run engine in a well-ventilated area.
5. Wipe away any spilled fuel from engine and cultivator. Allow to dry.
6. Gas cap and gas cap vent screw should be turned down tightly before transporting cultivator in a vehicle.

LONG TERM STORAGE

If your cultivator will not be used for more than one month, prepare it for long term storage.

Steps for long Term Storage

1. Remove the remainder of the fuel from the gas tank into an approved fuel container.
2. Store cultivator engine in a vertical position.
3. Remove all debris from cultivator tines and engine.

SERVICE INFORMATION

This Cultivator is built with quality for long-lasting durability, but no amount of careful design by us, and careful maintenance by you, can guarantee a repair-free life for your machine. Most repairs will be minor, and easily fixed by following the suggestions in the troubleshooting guide in this section.

The guide will help you pinpoint the causes of common problems and identify remedies.

For more complicated repairs, contact customer service.



CAUTION

TO AVOID INJURY OR DEATH, NEVER SIPHON FUEL BY MOUTH.

NEVER STORE CULTIVATOR WITH FUEL IN THE FUEL TANK INSIDE AN ENCLOSED AREA OR BUILDING.

PRACTICE SAFETY. ENGINE MUST BE TURNED OFF AND ALLOWED TO COOL, AND SPARK PLUG WIRE MUST BE DISCONNECTED BEFORE ATTEMPTING ANY MAINTENANCE OR REPAIR.

TROUBLESHOOTING GUIDE

PROBLEM	POSSIBLE CAUSE	REMEDY/ACTION
Engine will not start	1. Power switch off	1. Flip switch to ON position
	2. Spark plug wire disconnected	2. Connect spark plug wire to spark plug
	3. Out of fuel	3. Refuel
	4. Spark plug wet, faulty or improperly gapped	4. Clean, replace or gap spark plug
	5. Fuel line hose not positioned in bottom of gas tank	5. Push fuel line down into fuel in gas tank
Engine runs rough, floods during operation	1. Dirty air filter	1. Clean or replace air filter
	2. Choke partially engaged	2. Turn off choke
	3. Carburetor out of adjustment	3. Call customer service
Engine is hard to start	1. Stale fuel	1. Drain old fuel and replace with fresh. Use gas stabilizer at end of season
	2. Spark plug wire loose	2. Make sure spark wire is securely attached to spark plug
	3. Dirty carburetor	3. Clean carburetor, use gas stabilizer, new gas can
	4. Throttle control not held open	4. Prime unit 3 more times, then pull recoil handle
Engine misses or lacks power	1. Clogged gas tank	1. Remove and clean gas tank
	2. Clogged air filter	2. Clean or replace air filter
	3. Carburetor out of adjustment or bad	3. Call customer service
	4. Spark plug wet, faulty or improperly gapped	4. Clean, replace or gap spark plug
Engine runs, then quits	1. Gas cap not venting	1. Clean or replace gas cap, check vent
	2. Plugged fuel filter	2. Clean or replace fuel filter
	3. Carburetor out of adjustment or bad	3. Call customer service
Engine revs too high	1. Carburetor out of adjustment	1. Call customer service
Tines turn at idle	1. Idle speed too high	1. Adjust idle speed lower
	2. Broken clutch spring	2. Replace spring

ENGINE PARTS EXPLOSION

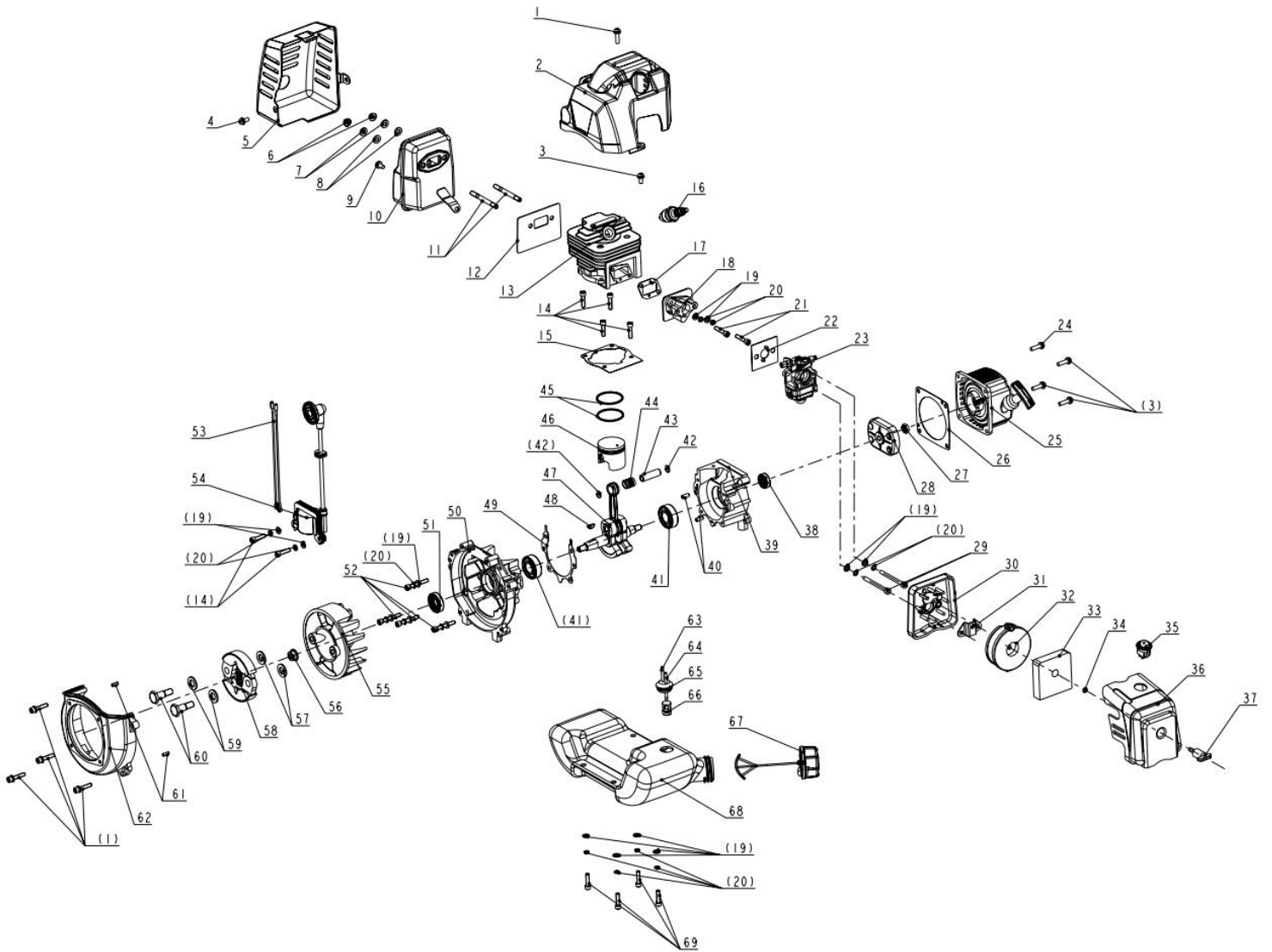

ENGINE PARTS LIST

NO.	PART NO.	DESCRIPTION	QTY
1	B13080502321	Bolt Assy, M5×23	5
2	26020104009009	Engine Shield assy	1
3	B13080501621	Bolt Assy, M5×16	4
4	B13080501221	Bolt Assy, M5×12	1
5	37090104001000	Muffler Cover	1
6	B04280600026	Nut,M6	2
7	B07000006041	Spring Washer, 6	2
8	B07010006041	Washer, 6	2
9	B02210501021	Bolt, M5×10	1
10	27060104011000	Muffler Ass'y	1
11	B03070606381	Stud Bolt,AM6X63	2
12	32050104001000	Gasket, Muffler	1
13	32030104001000	Cylinder	1
14	B02040502061	Bolt,M5×20	6
15	32040104001001	Gasket, Cylinder	1
16	22030404001000	Spark Plug,L6	1
17	32020104001001	Gasket, Cylinder Intake	1
18	22020104001000	Isolator Block, Carburetor	1
19	B07010005041	Washer, 5	14
20	B07000005041	Spring Washer, 5	14
21	B02040502561	Bolt,M5×25	2
22	32010104001001	Gasket, Carburetor	1
23	27030104001000	Carburetor Ass'y	1
24	B13080502021	Bolt Assy, M5×20	1
25	26040104011000	Handle assy,Recoil Starter	1
26	36090104001001	Gasket, Recoil Starter	1
27	36030104001000	Nut	1
28	26030104011000	Starting Jaw Assy	1
29	B02040505561	Bolt, M5×55	2
30	27050104001000	Housing, Air Filter	1
31	27040104001000	Bracket, Air Filter Mounting	1
32	27030104011000	Air Filter and Mounting Plate	1
33	37140104001000	Foam Element, Pre-Filter	1
34	B220100315A0	O-ring,3.15×1.8	1
35	28070104001000	Flameout Switch Ass'y	1

NO.	PART NO.	DESCRIPTION	QTY
36	37130104001000	Cover, Air Filter	1
37	27110104001000	Knob, Assy	1
38	31050101001000	Oil Seal,12×22×7	1
39	31100104001000	Right Crankcase	1
40	B09030501200	Pin,B5×12	2
41	B12016020200	Bearing,6202	2
42	34040104001000	Circlip,Piston Pin	2
43	34020104001000	Piston Pin	1
44	34010104001000	Needle Bearing,K10×13×15	1
45	34030104001000	Piston Ring	2
46	24020104001000	Piston	1
47	24040104001000	Crankshaft Connecting Rod Ass'y	1
48	B11210305013	Key,3×5×13	1
49	31030104001000	Gasket, Crankcase	1
50	31090104001000	Left Crankcase	1
51	31010104001000	Oil Seal,15×30×7	1
52	B02040503561	Bolt,M5×35	4
53	28090104001000	Flameout Line Ass'y	1
54	28080104001000	Ignition Coil	1
55	28050104001000	Rotor Assy	1
56	B04280800025	Nut,M8	1
57	35030104001000	Washer	2
58	25010104001000	Clutch Rotor Assy	1
59	33150132001000	Washer, Spring	2
60	35010104001000	Bolt, Shoulder	2
61	B09030401000	Pin,B4×10	2
62	31070104001000	Magneto Cover	1
63	37110104001001	Fuel Line 1	1
64	37100104001001	Fuel Line 2	1
65	37120104001000	Seal, Fuel Lines	1
66	27100104001000	Fuel Filter	1
67	27090104001000	Fuel Cap	1
68	27080104001000	Fuel Tank	1
69	B02040501861	Bolt , M5×18	4

PARTS DIAGRAM

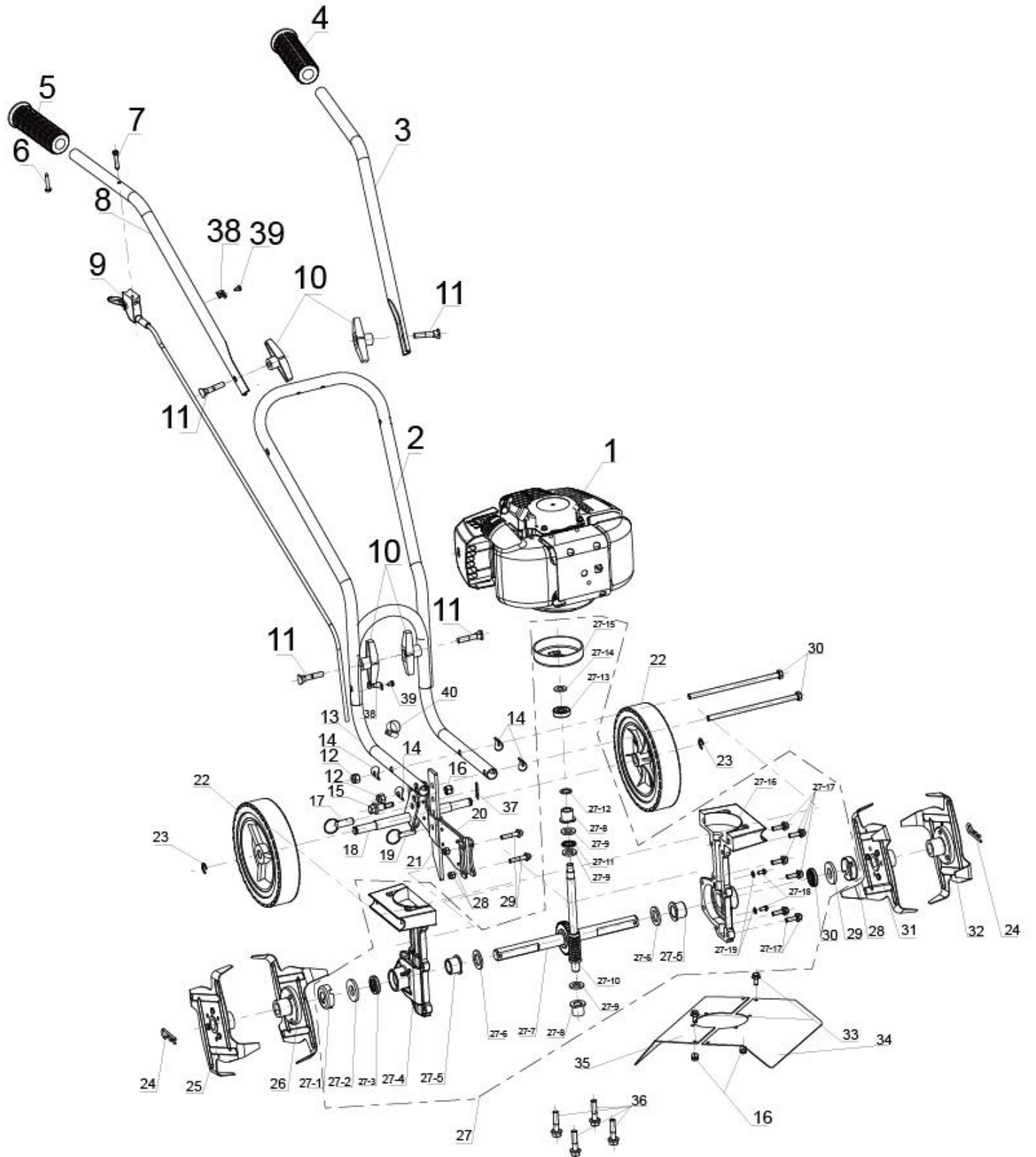

PARTS LIST

NO.	PART NO	DESCRIPTION	QTY
1	101040240001000	Engine	1
2	30050710101090	Middle-handle	1
3	30010710101090	Left-Upper Handle	1
4	30020710101800	Left-Handle Grip	1
5	30030710101800	Right-Handle Grip	1
6	B050142012C5	Tapping Screw	1
7	31690810101030	Tapping Screw	1
8	30040710101090	Right-Lower Handle	1
9	20030711201000	Throttle Assy	1
10	30310820301001	T-Shape Knob	4
11	30080710101020	Tubular Bolt II	4
12	B04340800046	Nylon self-locking nut	2
13	30060710101090	Lower-handle	1
14	30100710101020	Tubular gasket	4
15	3105071010000	Flange Pivot Bolt	1
16	B04340600046	Nylon lock nut	3
17	30880710101020	Safe pins	1
18	20040711201010	Wheel axle assy	1
19	30140710101020	Safe pins	1
20	20010711201020	Bracket Assy	1
21	30120710101090	Stake, Depth	1
22	20050820102000	Wheel	2
23	B08100000911	E-ring	2
24	30160710101020	R-pins	2
25	20120710101000	Right-outer tine Assy	1
26	20110710101000	Right-inside tine Assy	1
27	20090710101045	Gearbox Assembly	1
27-1	30350710101000	Oil seal protection cover	2
27-2	30370710101000	bondacust	2
27-3	30270710101800	Oil sea	2
27-4	30260710101000	Right-Case	1
27-5	30280710101000	Powder metallurgy bearing	2
27-6	30290710101000	Flat washer	2

27-7	20140710101000	Worm-gear axle Assy	1
27-8	30310710101000	Big copper sleeve	2
27-9	30330710101000	Flat washer I	3
27-10	30300710101000	Worm-shaft	1
27-11	30340710101000	needle bearing	1
27-12	30320710101000	Copper gasket	1
27-13	B12016000100	Bearing	1
27-14	3020023N911050	Washer	1
27-15	30360710101000	Cluth Shoes Assy	1
27-16	30250710101000	Left-case	1
27-17	B01330602066	Hexagon flange bolt	6
27-18	B02210500826	Cross Recess Head Screw	2
27-19	B07030005046	Washer	2
28	B04340600046	Nylon self-locking nut	2
29	B01330603066	Hexagon flange bolt	2
30	30090710101020	Bolt	2
31	20100710101000	Left-inside tine Assy	1
32	20090710101000	Left-outer tine Assy	1
33	B01310601266	Hexagon flange bolt	2
34	31000710101750	Front Tine Shielder	1
35	31010710101750	Rear Tine Shielder	1
36	B01330603566	Hexagon flange bolt	4
37	31430890100020	R-pins	1
38	30240710101030	Fastener	2
39	B05034209EC7	Tapping Screw	2
40	20070710101020	Adjustable hoop	1

EMISSION CONTROL SYSTEM WARRANTY

Buffalo Corp.

Your Warranty Rights and Obligations

The California Air Resources Board, The United States Environmental Protection Agency (US EPA) and Buffalo Corp. are pleased to explain the exhaust and evaporative emissions control system warranty on your 2021 model year small off-road engine. In California, new equipment that use small off-road engines must be designed, built, and equipped to meet the State's stringent anti-smog standards. Buffalo Corp. must warrant the emissions control system on your small off-road engine for the periods of time listed below provided there has been no abuse, neglect or improper maintenance of your small off-road engine or equipment leading to the failure of the emissions control system.

Your emissions control system may include parts such as the carburetor or fuel-injection system, the ignition system, catalytic converter, fuel tanks, fuel lines (for liquid fuel and fuel vapors), fuel caps, valves, canisters, filters, clamps and other associated components. Also included may be hoses, belts, connectors, and other emission-related assemblies. Where a warrantable condition exists, Buffalo Corp. will repair your small off-road engine at no cost to you including diagnosis, parts and labor.

Manufacturer's Warranty Coverage:

The exhaust and evaporative emissions control system on your small off-road engine is warranted for two years. If any emissions-related part on your small off-road engine is defective, the part will be repaired or replaced by Buffalo Corp.

Owner's Warranty Responsibility

As the small off-road engine owner, you are responsible for the performance of the required maintenance listed in your owner's manual. Buffalo Corp. recommends that you retain all receipts covering maintenance on your small off-road engine, but Buffalo Corp. cannot deny warranty coverage solely for the lack of receipts or for your failure to ensure the performance of all scheduled maintenance.

As the small off-road engine owner, you should however be aware that Buffalo Corp. may deny you warranty coverage if your small off-road engine or a part has failed due to abuse, neglect, or improper maintenance or unapproved modifications.

You are responsible for presenting your small off-road engine to a Buffalo Corp. distribution center or service center as soon as the problem exists. The warranty repairs shall be completed in a reasonable amount of time, not to exceed 30 days.

If you have any questions regarding your warranty rights and responsibilities, you should contact Buffalo Corp. customer service representative at 1-866-460-9436 or write to info@buffalotools.com.

DEFECTS WARRANTY COVERAGE

Adopted by the Air Resources Board, Buffalo Corp. warrants to the ultimate purchaser and each subsequent purchaser that the small off-road engine (SORE)(1) has been designed, built and equipped so as to conform with all applicable regulations; and (2) is free from defects in materials and workmanship that cause the failure of a warranted part to conform with those regulations as may be applicable to the terms and conditions stated below.

(a) The warranty period begins on the date the engine is delivered to an ultimate purchaser or first placed into service. The warranty period is two years.

(b) Subject to certain conditions and exclusions as stated below, the warranty on emissions related parts is as follows:

(1) Any warranted part that is not scheduled for replacement as required maintenance in your Owner's Manual is warranted for the warranty period stated above. If the part fails during the period of warranty coverage, the part will be repaired or replaced by Buffalo Corp. according to Subsection (4) below. Any such part repaired or replaced under warranty will be warranted for the remainder of the periods.

(2) Any warranted part that is scheduled only for regular inspection in your owner's manual is warranted for the warranty period stated above. Any such part repaired or replaced under warranty will be warranted for the remaining warranty period.

(3) Any warranted part that is scheduled for replacement as required maintenance in your owner's manual is warranted for the period of time before the first scheduled replacement date for that part. If the part fails before the first scheduled replacement, the part will be repaired or replaced by Buffalo Corp. according to Subsection (4) below. Any such part repaired or replaced under warranty will be warranted for the remainder of the period prior to the first scheduled replacement point for the part.

(4) Repair or replacement of any warranted part under the warranty provisions herein must be performed at a warranty station at no charge to the owner.

(5) Notwithstanding the provisions herein, warranty services or repair will be provided at all of our distribution centers that are franchised to service the subject engines.

(6) The engine owner must not be charged for diagnostic labor that leads to the determination that a warranted part is in fact defective, provided that such diagnostic work is performed at a warranty station.

(7) Buffalo Corp. is liable for damages to other engine components proximately caused by a failure under warranty of any warranted part.

(8) Throughout the engine warranty period stated above, Buffalo Corp. will maintain a supply of warranted part sufficient to meet the expected demand for such parts.

(9) Any replacement may be used in the performance of any warranty maintenance or repairs and must be provided without charge to the owner. Such use will not reduce the warranty obligations of Buffalo Corp.

(10) Add-on or modified parts that are not exempted by the Air Resources Board may not be used. The use of any non-exempted add-on or modified parts by the ultimate purchaser will be grounds for disallowing a warranty claims. Buffalo Corp. will not be liable to warrant failures of warranted parts caused by the use of a non-exempted add-on or modified part.

(11) The manufacturer issuing the warranty shall provide any documents that describe that manufacturer's warranty procedures or policies within five working days of request by the Air Resources Board.

EMISSION WARRANTY PARTS LIST

(1) Fuel Metering System:

- (a) Gasoline carburetor assembly and its internal components
- (b) Carburetor gaskets
- (c) fuel lines (for liquid fuel and fuel vapors)
- (d) Clamps
- (e) Fuel tank
- (f) Fuel line fittings
- (g) Pressure regulator(if equipped)
- (h) Mixer assembly and its internal components (if equipped)

(2) Air induction system including:

- (a) Intake pipe/manifold
- (b) Air cleaner

(3) Ignition system including:

- (a) Spark plug
- (b) Ignition coil

(4) Catalytic muffler assembly including:

- (a) Muffler gasket
- (b) Exhaust manifold

(c) Catalytic converter

(5) Crankcase breather assembly including:

- (a) Breather connection tube

(6) Fuel tank evaporative emissions control system including:

(a) Purge valves

(b) Fuel cap

(c) Fuel tank

(d) fuel lines (for liquid fuel and fuel vapors)

(7) Miscellaneous items used in above systems including:

(a) Switches

(b) Hoses, belts connectors and assemblies

(8) Air injection system

(a) Pulse valve

Please Note:

For this warranty, Buffalo Corp. shall warrant the Evaporative and Exhaust combined emission control system on your products.

2021 01