

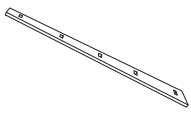







Assembly Instruction

ITEM#CVFZR698

PARTS LIST						HARDWARE LIST			
NO.	DESCRIPTION		QTY	NO.	DESCRIPTION	QTY	NO.	DESCRIPTION	QTY
A	frame		2	C	the 1st shelf 	1	H	provide tool 	1
				D	the 2nd shelf 	1			
				E	the 3rd shelf 	1			
B	card holder		10	F	the 4th shelf 	1			
				G	the 5th shelf 	1			

Step 1

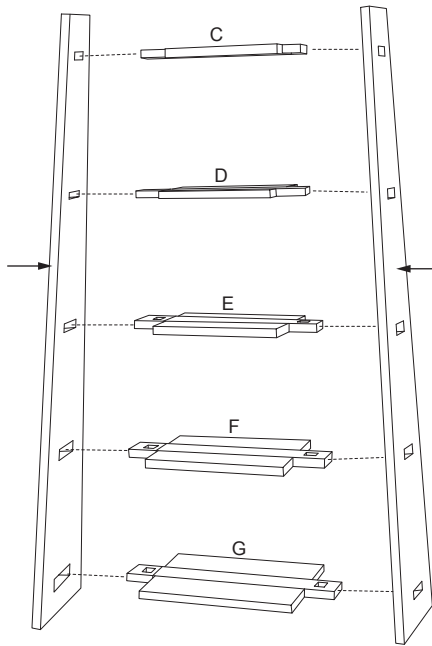

Step 2

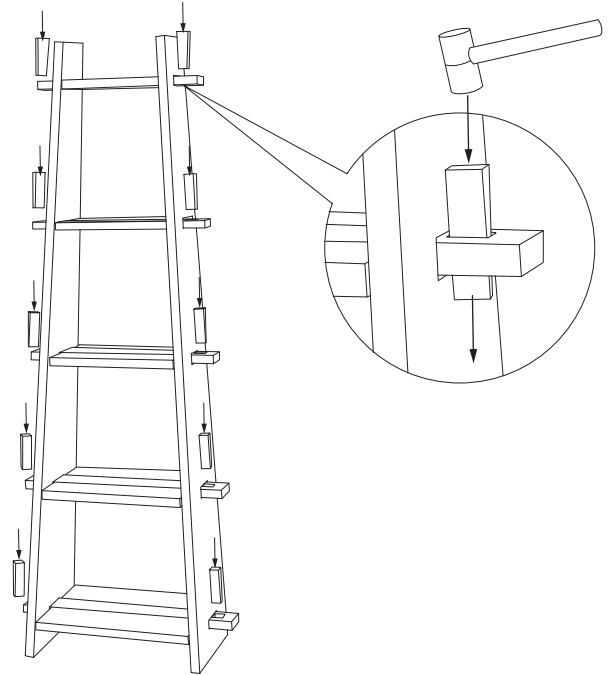

Completion

