

Instruction Manual

2 LIGHT LED WINE RACK

Questions?

E-mail our customer service department at customerservice@alltherages.com

IMPORTANT SAFETY INSTRUCTIONS:

- **TURN OFF ELECTRICITY** at main fuse box (or circuit breaker box) before beginning installation by switching circuit breaker off or removing fuse.
- **If in doubt about electrical installation, consult a licensed electrician.**

PART	QTY
MOUNTING PLATE	1
WIRE NUTS	3
GREEN SCREW	1
OUTLET BOX SCREWS	2
WINE RACK BASE	1
ILLUMINATION HOUSING	1
EXTENSION POLES (8", 12", 16")	12
BRACKET CONNECTORS	4
CANOPY SUPPORT	1
CEILING CANOPY	1
STEEL WASHER	4
RUBBER WASHER	2
WING NUTS	4
DECORATIVE NUTS	2
SCREWS (PRE-ATTACHED)	16
CROSS BEAM SCREWS	4

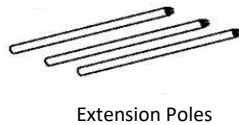
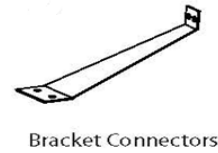
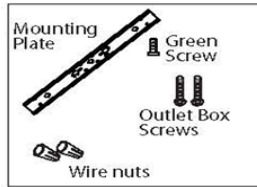

CLEANING & MAINTENANCE:

1. Turn off the fixture before cleaning.
2. Use a clean, dry, soft, lint-free cloth.
3. Do not use water or other chemical cleaning agents.

**THIS WINE RACK COMES WITH PRE-INSTALLED LED BULBS.
THE BULBS ARE NOT REPLACEABLE.
THESE LED BULBS SHOULD LAST FOR 50,000 HOURS.**

INSTRUCTIONS:

Before beginning assembly and installation of product, make sure all parts are present. Compare parts with package contents list and diagram above. If any part is missing or damaged, do not attempt to assemble, install or operate the product. Contact customer service for replacement parts.

Estimated Assembly Time: 60 minutes

Tools Required for Assembly: Phillips screwdriver (not included)

Helpful Tools: Wire cutter (not included)

Step 1: TURN OFF ELECTRICITY at main fuse box (or circuit breaker box) before beginning installation by switching circuit breaker off or removing fuse.

MIN 60° C SUPPLY CONDUCTORS.

CONSULT A QUALIFIED ELECTRICIAN TO ENSURE CORRECT BRANCH CIRCUIT CONDUCTOR.

Step 2: Place wine rack base (13) on clean flat surface. Unscrew eight screws (15) from two metal plates (14) on top of wine rack base edges. Unscrew eight side screws (17) from both sides of illumination housing (16).

Step 3: Attach four bracket connectors (18) to wine rack base (13) and illumination housing (16) as follows. Screw bottom wide end of four bracket connectors (18) to wine rack base (13) with two screws (15) each. Then attach sides of illumination housing (16) to top thin end of four bracket connectors (18) with two side screws (17) each.

Step 4: This wine rack comes with three extension poles. The lengths are 8 inch, 12 inch and 16 inch. Confirm how low you wish the wine rack to hang from the ceiling using one or two or all three of the extension poles. Thread the black, white and ground wires up from the illumination housing (16) through one set of extension poles (21), (22) and (23), and then through the ceiling canopy (24) and canopy support (25).

Step 5: Screw bottom extension pole (21) onto protruding threaded nipple (26) on top of illumination housing (26). Screw middle extension pole (22) onto bottom extension pole (21), and screw upper extension pole (23) onto middle extension pole (22). Repeat this step for all three sets of extension poles. Place all four upper extension poles (23) through four holes in ceiling canopy (24) and through four holes in canopy support (25). Place steel washers (27) onto the four protruding upper extension poles (23) and fasten with wing nuts (28).

Step 6: Screw 1/4 inch diameter screws through mounting plate(7) onto cross beams in ceiling.

IMPORTANT NOTE: THIS WINE RACK WEIGHS APX 50 LBS (22.68 KGS.) AND WILL HAVE ADDITIONAL WEIGHT ADDED TO IT WHEN WINE BOTTLES AND GLASSES ARE PLACED ONTO IT.

TO HANG CEILING MOUNTED FIXTURES WEIGHING 50 LBS. (22.68 KGS.) OR MORE (OR 25 LBS. (11.34 KGS.) OR MORE IN CANADA), THE MOUNTING PLATE (7) MUST BE SUPPORTED INDEPENDENTLY OF THE CEILING OUTLET BOX (8). RECOMMENDED MINIMUM IS TWO SCREWS OR BOLTS 1/4 INCH (6.35 MM) DIAMETER (RATED FOR 200 LBS. (90.72 KG.) OR GREATER) THAT MUST HAVE SUFFICIENT LENGTH TO BE INSTALLED INTO THE CROSS BEAMS OF THE CEILING. USED SUPPLIED CROSS BEAMS SCREWS TO SECURE TO CROSS BEAMS. THIS INSTALLATION WOULD BE ABLE TO SUPPORT AT LEAST FOUR TIMES THE WEIGHT OF THE FIXTURE. IF UNSURE PLEASE CONSULT A QUALIFIED TECHNICIAN.

Step 7: Fasten mounting plate (7) onto the outlet box (8) using two outlet box screws (9). The protruding side lips and mounting screws (6) of mounting plate (7) must face down. Fasten mounting plate (7) against ceiling, independently of the outlet box as described in above note. Secure two to four 4 inch bolts (not included) through the four holes around the middle hole in the mounting plate (7), then through the outlet box holes, and securely into the ceiling structure member or cross brace.

Step 8: Strip 3/4 inch of insulation from wire ends of fixture and of supply circuit wires. Attach ground supply circuit wire (10) and ground fixture wire (11) to the mounting plate (7) with the green screw (12) provided. (Alternatively, if there is no ground supply circuit wire, only attach the ground fixture wire (11) to the mounting plate (7) with the green screw (12)). Never connect ground wire to black or white power supply wires. Twist stripped wire ends of fixture and supply circuit wires together black to black (hot) (3) and white to white (neutral) (4). Twist on wire nuts (5). Tape wire nuts and wires together. Carefully tuck connected wires and wire nuts into outlet box.

Step 9: Place ceiling canopy (24) and canopy support (25) up against mounting plate (7), fitting the two mounting screws (6) through the two holes in the ceiling canopy (24) and canopy support (25). Place rubber washers (29) onto mounting screws (6) and fasten with the decorative nuts (30).

ASSEMBLY AND INSTALLATION INSTRUCTIONS

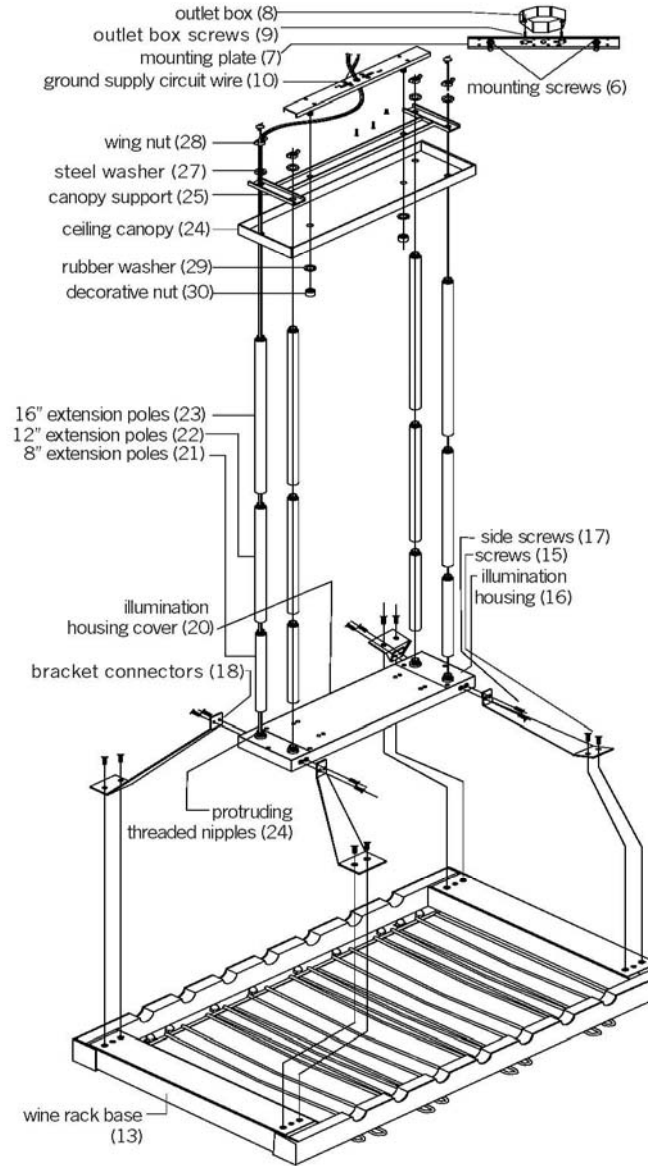
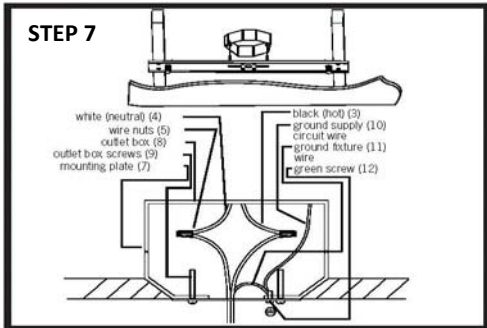
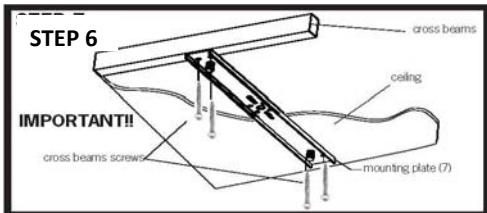
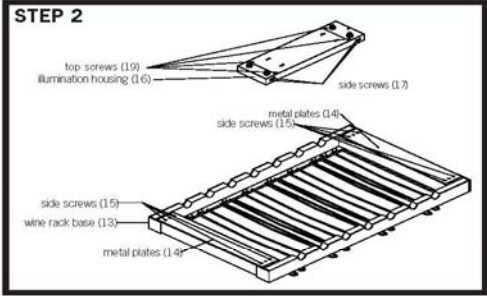

LIMITED WARRANTY

All the Rages Inc, a New Jersey corporation, having its principal place of business at 355 Eisenhower Parkway Livingston, NJ 07039 (All the Rages) warrants its products (the "products") as follows:

1. Limited Warranty.

Manufacturer warrants that the products sold hereunder will be free from defects in material and workmanship for a period of one (1) year from the date of purchase. If the products do not conform to this Limited Warranty during the warranty period (as herein above specified), Buyer shall notify Manufacturer in writing of the claimed defects and demonstrate to Manufacturer's satisfaction that said defects are covered by this Limited Warranty. If the defects and proof of purchase are properly reported to Manufacturer within the warranty period, and the defects are of such type and nature as to be covered by this warranty, Manufacturer shall, as its own expense, furnish replacement products or, at Manufacturer's option, replacement parts for the defective products. Installation of the replacement products or replacement parts shall be at Buyer's expense.

2. Exclusive Obligation:

THIS WARRANTY IS EXCLUSIVE. The sole and exclusive obligation of Manufacturer shall be to repair or replace the defective products in the manner and for the period provided above. Manufacturer shall not have any other obligation with respect to the products or any part thereof, whether based on contract, tort, strict liability or otherwise. Under no circumstances, whether based on this Limited Warranty or otherwise, shall Manufacturer be liable for incidental, special, or consequential damages.

3. Other Statements.

Manufacturer's employees or representatives' oral or other written statements do not constitute warranties, shall not be relied upon by Buyer, and are not part of the contract for sale or this limited warranty.

4. Entire Obligation.

This Limited Warranty states the entire obligation of Manufacturer with respects to the products. If any part of this Limited Warranty is determined to be void or illegal, the remainder shall remain in full force and effect.



ALL THE RAGES INC
355 EISENHOWER PARKWAY
LIVINGSTON, NJ 07039
WWW.ALLTHERAGES.COM
PRINTED IN CHINA