

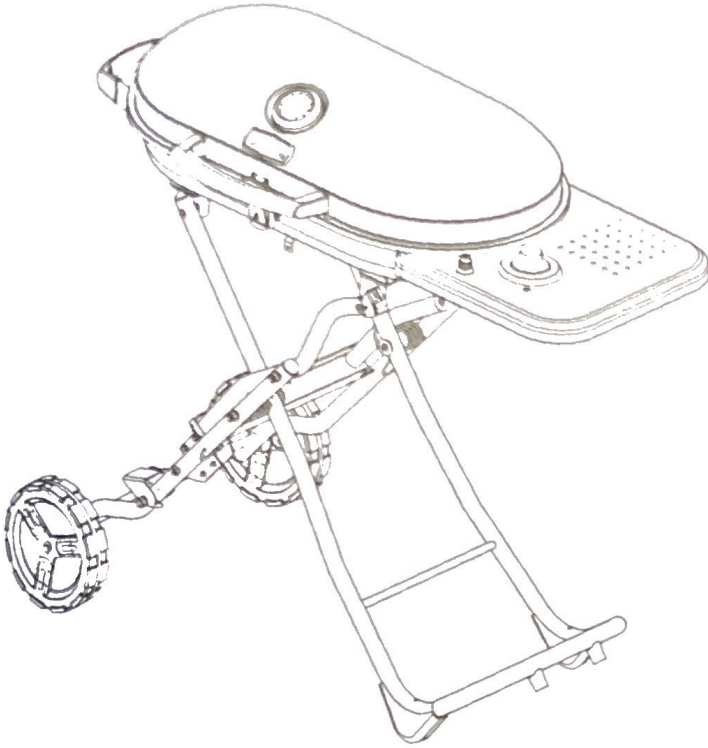

# USER MANUAL

FOLDING GAS GRILL  
STG1150HD/STG1150

FOR OUTDOOR USE ONLY  
LP GAS CYLINDER SOLD SEPERATELY



**NOTE TO INSTALLER/ASSEMBLER:** Give this Operator's Manual to the consumer so the consumer may retain it for future reference.

**⚠ DANGER:**

You WILL be KILLED or SERIOUSLY HURT if you do not follow the instructions in this operator's manual.

**SAVE THIS MANUAL FOR FUTURE REFERENCE**

# TABLE OF CONTENTS

■ Introduction .....	2
■ General Safety Rules .....	3-4
■ Specific Safety Rules .....	4
■ Symbols .....	5
■ Features .....	6
■ Loose Parts .....	7
■ Tools Needed .....	7
■ Assembly .....	8-12
■ Operation .....	13-15
■ Maintenance .....	16-17
■ Troubleshooting .....	18
■ Warranty .....	19
■ Parts Ordering/Service .....	Back Page

## INTRODUCTION

This grill has many features for making its use more pleasant and enjoyable. Safety, performance, and dependability have been given top priority in the design of this product making it easy to maintain and operate. This instruction manual contains important information necessary for the proper assembly and safe use of the appliance. Read and follow all warnings and instructions before assembling and using the appliance. Keep this manual for future reference.

### **DANGER:**

If you smell gas:

- Shut off gas to the appliance
- Extinguish any open flame.
- Open firebox hood.
- If odor continues, keep away from the appliance and immediately call your gas supplier or your fire department.

Failure to follow these instructions could result in fire or explosion which could cause property damage, personal injury or death.

### **DANGER:**

- Never operate this appliance unattended.
- Never operate this appliance within 25 ft. (7.5 m) of any flammable liquid.
- If a fire should occur, keep away from the appliance and immediately call your fire department. Do not attempt to extinguish an oil or a grease fire with water.

Failure to follow these instructions could result in fire, explosion or burn hazard which could cause property damage, personal injury or death.

### **DANGER:**

Always use outdoors. Using the grill indoors or within an enclosed area can lead to carbon monoxide poisoning, resulting in serious injury or death.

### **WARNING:**

- Do not store or use gasoline or other flammable liquids or vapors in the vicinity of this or any other appliance.
- An LP cylinder not connected for use shall not be stored in the vicinity of this or any other appliance.

### **WARNING:**

Improper assembly, adjustment, alteration, service, or maintenance can cause property damage, injury, or death. Read the Assembly, Operation, and Maintenance instructions thoroughly before use, assembly, or servicing of this product.



## GENERAL SAFETY RULES

### **WARNING:**

**Read and understand all instructions.** Failure to follow all instructions listed below, may result in electric shock, fire and/or serious personal injury.

### READ ALL INSTRUCTIONS

- This appliance must be installed in accordance with the latest local codes. In the absence of local codes, use the:
  - **United States:**
    - National Fuel Gas Code, ANSI Z223.1/NFPA 54
    - LP gas Code, NFPA 58
  - **Canada:**
    - Natural Gas and Propane Installation Code, CSA B149.1
    - Propane Storage and Handling Code, CSA B149.2
- If an accessory is used on the grill that requires an external electrical power source, the accessory when installed must be electrically grounded in accordance with local codes. In the absence of local codes, use the:
  - **United States:** National Electrical Code, ANSI/NFPA 70
  - **Canada:** Canadian Electrical Code, CSA C22.1
- This appliance is for outdoor use only, and shall not be used in a building, garage, shed, balcony, or any other enclosed area.
- Do not use or install this appliance in or on boats or recreational vehicles.
- This grill must be located away from combustible surfaces by no less than 36 in. (914 mm) from back of grill and 36 in. (914 mm) from sides of this grill.

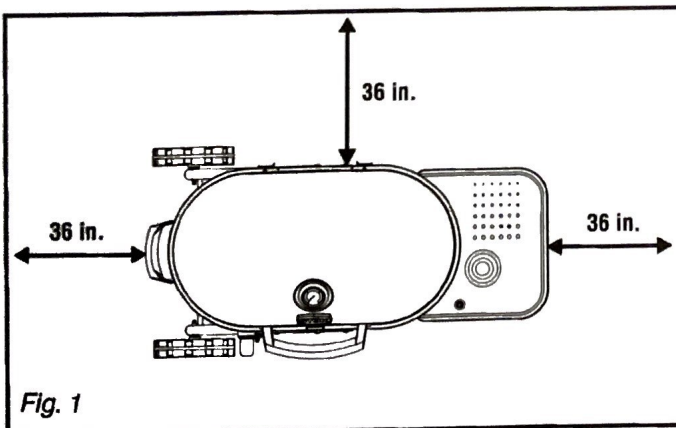

Fig. 1

- The grill shall not be used under overhead combustible construction.
- The grill is not intended for and should never be used as a heater.
- Keep area around this appliance free of combustible materials, gasoline, and all other flammable vapors and liquids.
- Do not restrict the flow of combustion and ventilation air.
- Keep ventilation openings of the cylinder enclosure free and clear from debris.
- This grill is not intended for commercial use.
- Never move grill when using or still hot.
- Never use the grill indoors. Toxic fumes can accumulate.
- Always remove the LP gas cylinder (liquid propane also called liquid petroleum gas) when the appliance is not in use or before storing or lowering the unit.
- Do not alter the grill in any manner.
- Do not use this appliance unless it is fully and properly assembled and all parts are securely fastened.
- Never attempt to light burner with the firebox hood closed. A build up of non-ignited gas inside a closed grill is hazardous.
- When in use, keep children and pets away at all times.
- Do not leave the grill unattended.
- Do not use charcoal, ceramic briquettes, or lava rock in a gas grill.
- In the event of a grease fire, turn off the burner. Do not attempt to extinguish with water. Use type BC dry chemical fire extinguisher or smother with dirt, sand, or baking soda.
- When cooking with oil or grease, have a type BC or ABC fire extinguisher readily available.
- Keep any electrical cord and fuel supply hose away from any heated surfaces.
- Do not store a spare LP gas cylinder under or near the grill. If not followed exactly, a fire causing death or serious injury may occur.

## GENERAL SAFETY RULES

- If a leak is detected at any time, get away from the LP gas cylinder and call the fire department.
- This grill is not intended to be used on a boat, in an RV, camper trailer, or motor home.
- Do not use the grill until leak-tested.
- Periodically check and/or clean the burner/venturi tubes for insects and insect nests. A clogged tube can lead to a fire beneath the grill.
- LP gas cylinders must be stored outdoors out of reach of children and must not be stored in a building, garage, or any other closed in area.
- Do not operate the grill while under the influence of drugs, alcohol, or any medication.
- Stay alert and exercise control. Watch what you are doing and use common sense. Do not operate a grill when you are tired.
- Propane cylinder use (1 lb. disposable):
  - Use only cylinder marked "Propane Fuel".
  - Cylinder must be constructed and marked in accordance with the specifications for LP gas cylinders of the U.S. Department of Transportation (DOT) or the National Standard of Canada, CAN/CSA-B339, Cylinders, Spheres and Tubes for the Transportation of Dangerous Goods.
  - Size should be 4 in. diameter, 8 in. height, or 3 in. diameter, 10 in. height.
  - Save cylinder cap and reinstall when not in use.
  - Cylinder supply system must be arranged for vapor withdrawal. Gas cylinder must be upright in use.



## SPECIFIC SAFETY RULES

- Use grill only with LP gas and the regulator/valve assembly supplied.
- Check for leaks prior to grilling operations. Do this even if this grill was assembled at the store.
- Do not operate the grill if there is a gas leak present.
- Never use a flame to check for gas leaks.
- Should the burner go out while grilling, turn off the gas valve. Open the firebox hood and wait five minutes before attempting to relight.
- Never lean over an open grill or place hands or fingers on hot surfaces.
- Thoroughly clean the grill regularly.
- Do not block the ventilation holes in the sides or back of the grill.
- Never attempt to use the appliance or any components that have been damaged or exposed to an accidental fire.
- Propane gas is not natural gas. Do not try to convert this grill to natural gas as it will void the warranty and is extremely dangerous.
- Place dust cap on cylinder valve outlet whenever the cylinder is not in use. Only install the type of dust cap on the cylinder valve outlet that is provided with the cylinder valve. Other types of caps or plugs may result in leakage of propane.
- Do not store or use gasoline or other flammable liquids or vapors in the vicinity of the grill.
- Use heat-resistant mitts or gloves, and long-handled utensils when operating this grill.
- When cooking, the grill must be on a level, stable noncombustible surface in an area that is free of combustible material. An asphalt surface (blacktop) may not be acceptable for this purpose.
- Apartment Dwellers: Check with management to learn requirements and fire codes of using a LP gas grill in your apartment complex.
- Save these instructions. Refer to them frequently and use them to instruct others who may use this grill. If you loan someone this grill, loan them these instructions also.





## SYMBOLS

The following signal words and meanings are intended to explain the levels of risk associated with this product.

SYMBOL	SIGNAL	MEANING
	<b>DANGER:</b>	Indicates an imminently hazardous situation, which, if not avoided, will result in death or serious injury.
	<b>WARNING:</b>	Indicates a potentially hazardous situation, which, if not avoided, could result in death or serious injury.
	<b>CAUTION:</b>	Indicates a potentially hazardous situation, which, if not avoided, may result in minor or moderate injury.
	<b>NOTICE:</b>	(Without Safety Alert Symbol) Indicates important information not related to an injury hazard, such as a situation that may result in property damage.

Some of the following symbols may be used on this product. Please study them and learn their meaning. Proper interpretation of these symbols will allow you to operate the product better and safer.

SYMBOL	NAME	DESIGNATION/EXPLANATION
	Safety Alert	Indicates a potential personal injury hazard.
	Read Operator's Manual	To reduce the risk of injury, user must read and understand operator's manual before using this product.
	Hot Surface	To reduce the risk of injury or damage, avoid contact with any hot surface.

# FEATURES

## PRODUCT SPECIFICATIONS

BTU rating .....	15,000	Fuel source .....	Propane (not included)
Total grill surface .....	348 sq. in.	Natural gas convertible .....	No
Grilling surface height .....	31 in.		

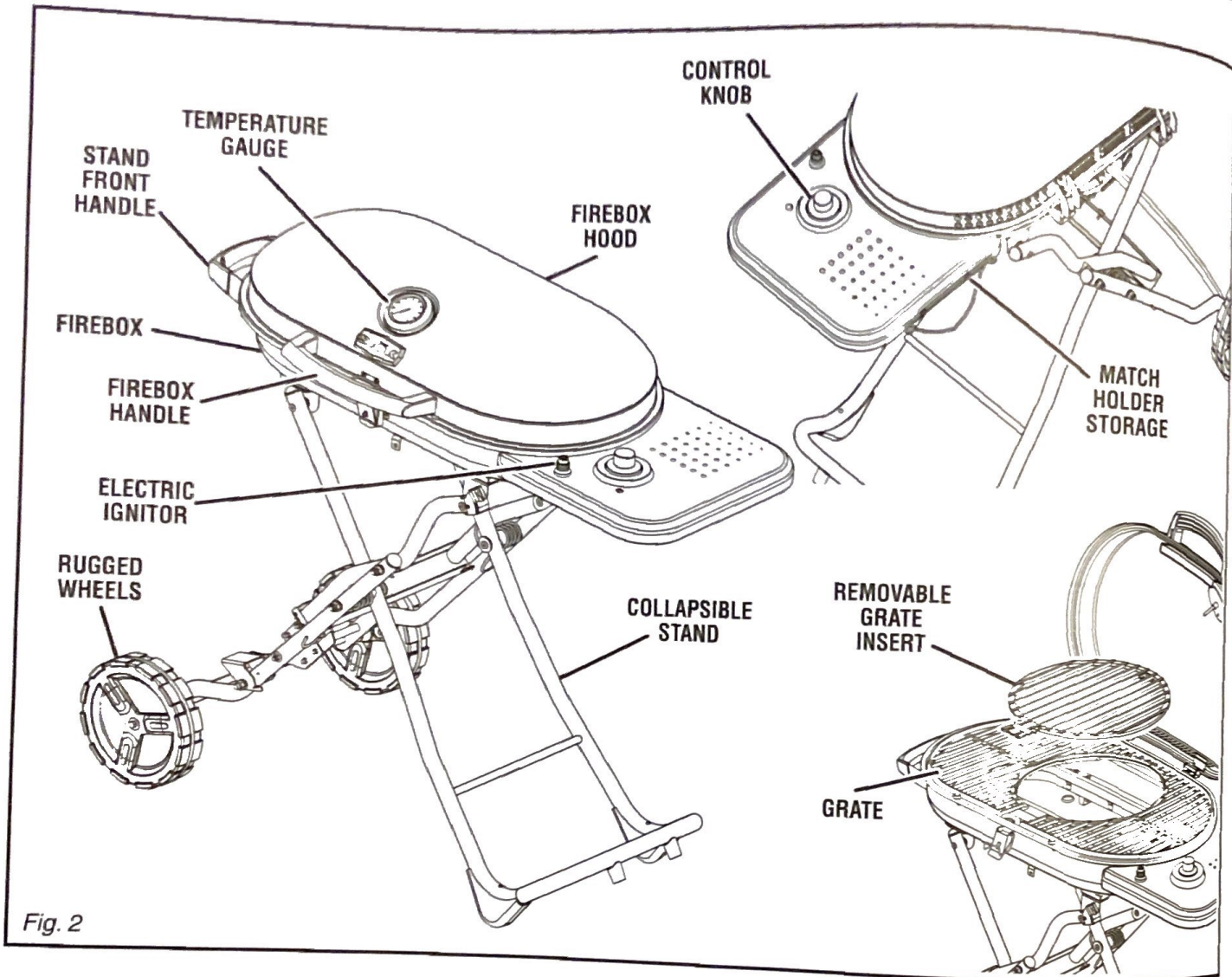

Fig. 2

## KNOW YOUR GRILL

See Figure 2.

The safe use of this grill requires an understanding of the information on the grill and in this operator's manual. Before use of this grill, familiarize yourself with all operating features and safety rules.

**COLLAPSIBLE STAND** - The stand can be collapsed for storing or transporting the grill.

**ELECTRIC IGNITOR** - The electric ignitor uses a AAA battery that lights the gas burner when pushed.

**FIREBOX HOOD** - The firebox hood can be locked for easy transport.

**MATCH HOLDER STORAGE** - Slots in the back of the grill provide convenient storage for the match holder.

**REMOVABLE GRATE INSERT** - Remove the round porcelain-coated, cast-iron grate insert when using the pizza stone or other available inserts (sold separately). When transporting be sure the cast-iron grate is installed.

**RUGGED WHEELS** - The durable plastic wheels allow you to move the grill across smooth and rough surfaces.

**TEMPERATURE GAUGE** - The temperature gauge measures temperatures up to 700°F.



## LOOSE PARTS

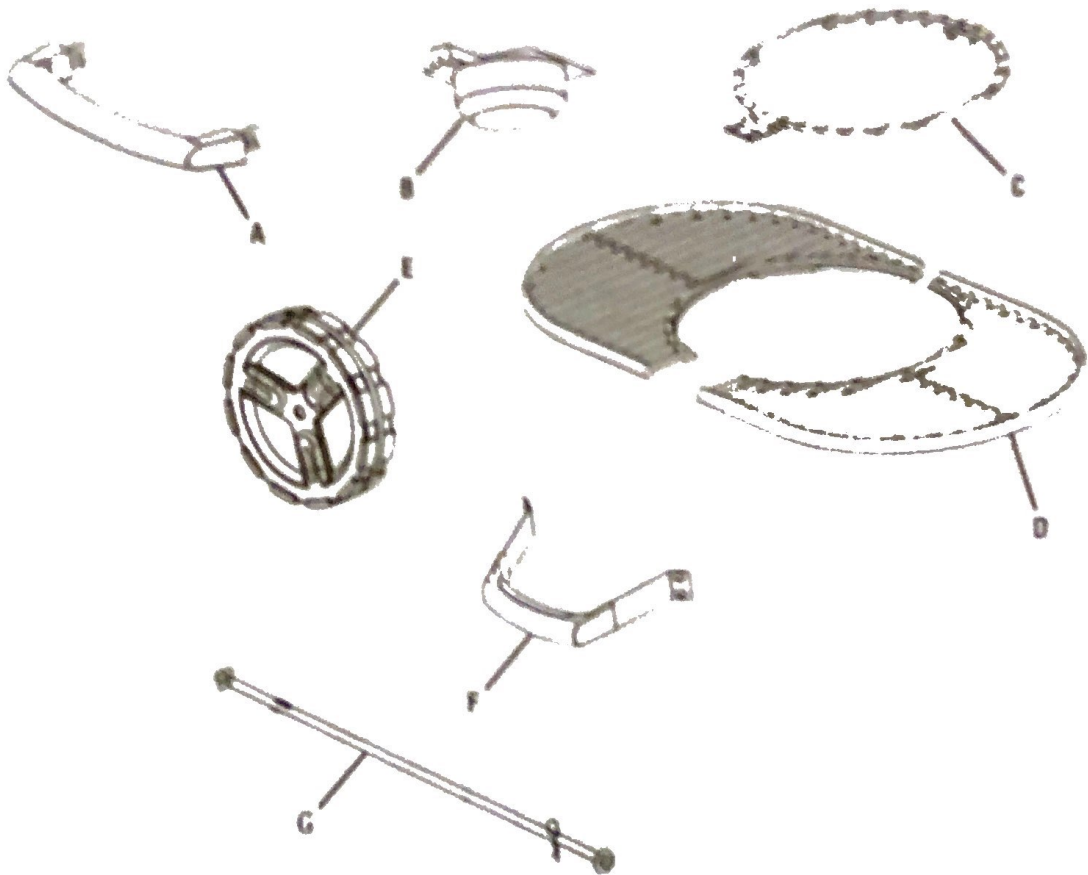

Fig 3

A - Firebox handle .....	1	F - Stand front handle .....	1
B - Grease cup .....	1	G - Axle .....	1
C - Grate insert .....	1	✶ AAA battery----- Please buy the AAA battery by yourself	
D - Grate .....	1		
E - Wheel .....	2		

## TOOLS NEEDED

The following tools (not included or drawn to scale) are needed for assembly and making adjustments:



PHILLIPS  
SCREWDRIVER

Fig 4

# ASSEMBLY

## UNPACKING

This product requires assembly.

- Carefully lift grill from the carton and place it on a level work surface.

### **WARNING:**

Do not use this product if any parts on the Loose Parts List are already assembled to your product when you unpack it. Parts on this list are not assembled to the product by the manufacturer and require customer installation. Use of a product that may have been improperly assembled could result in serious personal injury.

- Inspect the grill carefully to make sure no breakage or damage occurred during shipping.
- Do not discard the packing material until you have carefully inspected the grill, identified all loose parts, and satisfactorily operated the grill.

**NOTE:** Some loose parts are located inside the grill assembly beneath the firebox hood.

### **WARNING:**

If any parts are damaged or missing, do not operate this grill until the parts are replaced. Use of this product with damaged or missing parts could result in serious personal injury.

### **CAUTION:**

Some parts may contain sharp edges that may cause personal injury. Wear protective gloves if necessary.

## STEP 1: ATTACHING THE WHEELS

See Figure 5 - 6.

- With the grill out of the box and packaging removed, place the grill right side up on flat surface.
- Remove the hitch pin, screws, and washers from the axle.
- Locate the holes in the stand legs.
- Slide the axle through the square hole in the left stand leg and then through the round hole in the right stand leg.
- Install the hitch pin into the hole in the axle to secure it in place.
- Lift the grill, slide one washer and wheel onto the axle.
- Using a second washer and screw, secure the wheel to the stand. Securely tighten screw.
- Repeat this process to secure the other wheel.

## STEP 2: ATTACHING THE STAND FRONT HANDLE

See Figure 7.

- Locate the handle mounts on the firebox.
- Remove the screws, lock washers, and washers from the handle mounts.
- Align holes in stand front handle with holes in mounts.
- Install front handle using phillips screws. Securely tighten screws.

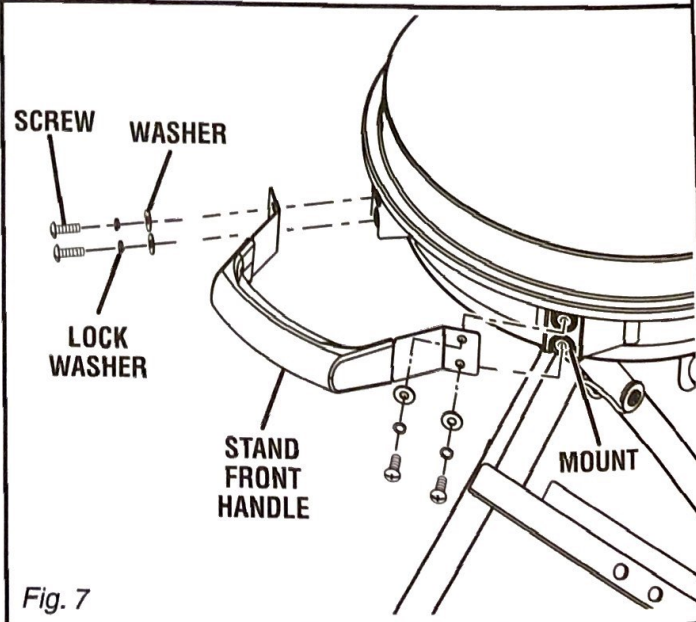
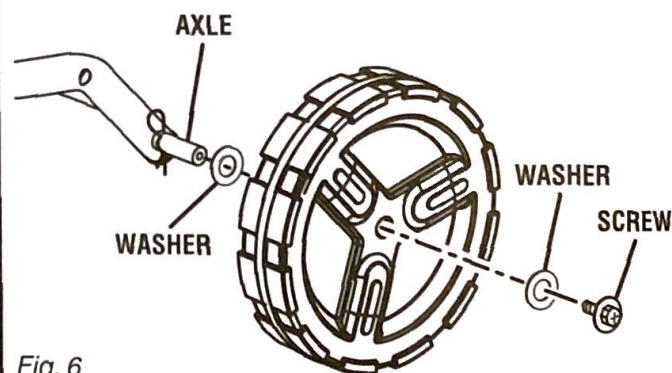
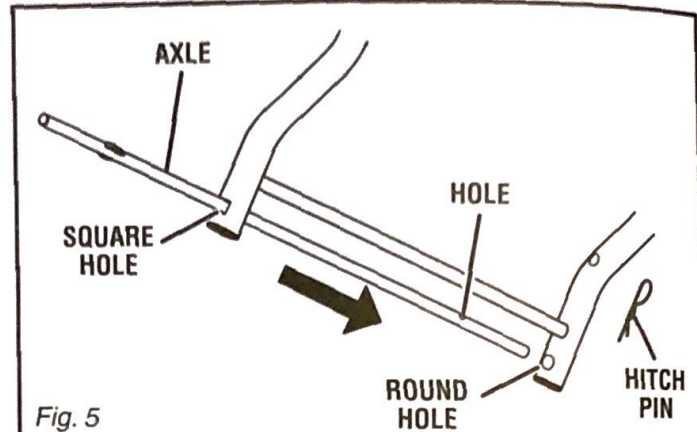



# ASSEMBLY

## STEP 3: OPENING THE STAND

See Figure 8 - 10.

- Grasp the stand front handle and raise the stand until it rests on the wheels and frame support.

### ⚠ WARNING:

Use the stand front handle to raise the stand. Do not raise by any part of the grill that is attached to the stand. Failure to heed this warning can result in possible injury and damage the grill.

- Step on the release lever and pull the stand front handle toward you at the same time.
- Apply slight downward pressure on the stand until the release lever closes over the center brace, locking the unit in place.

### ⚠ WARNING:

Failure to remove the LP gas cylinder or attempting to move the grill while it is hot could result in serious personal injury.

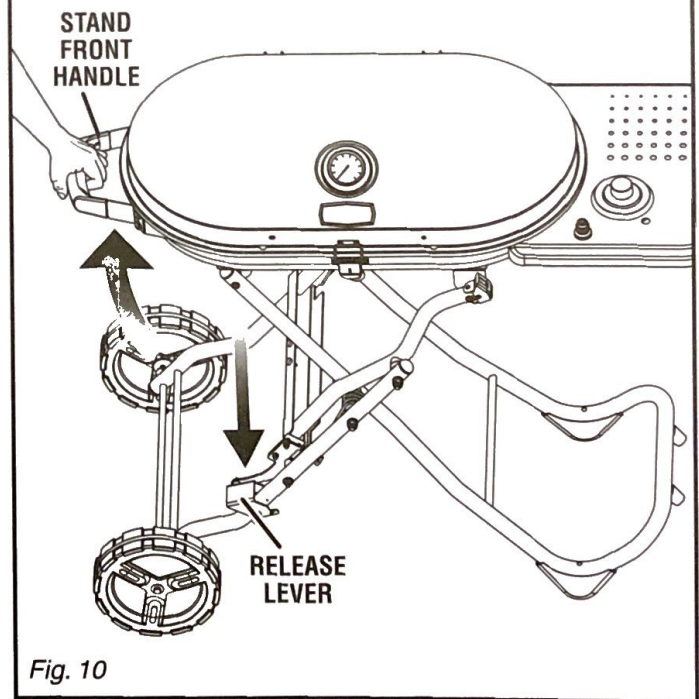
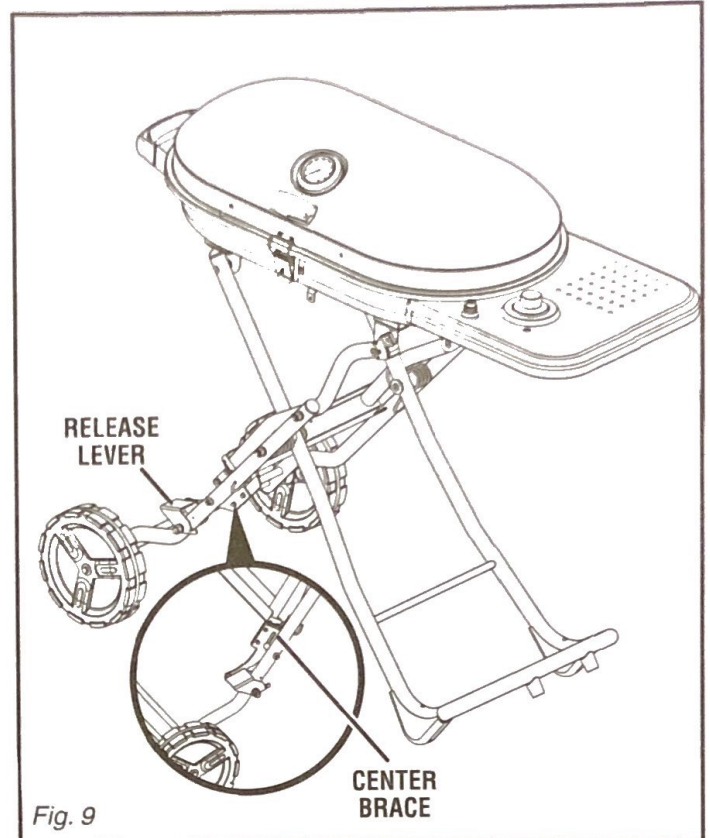
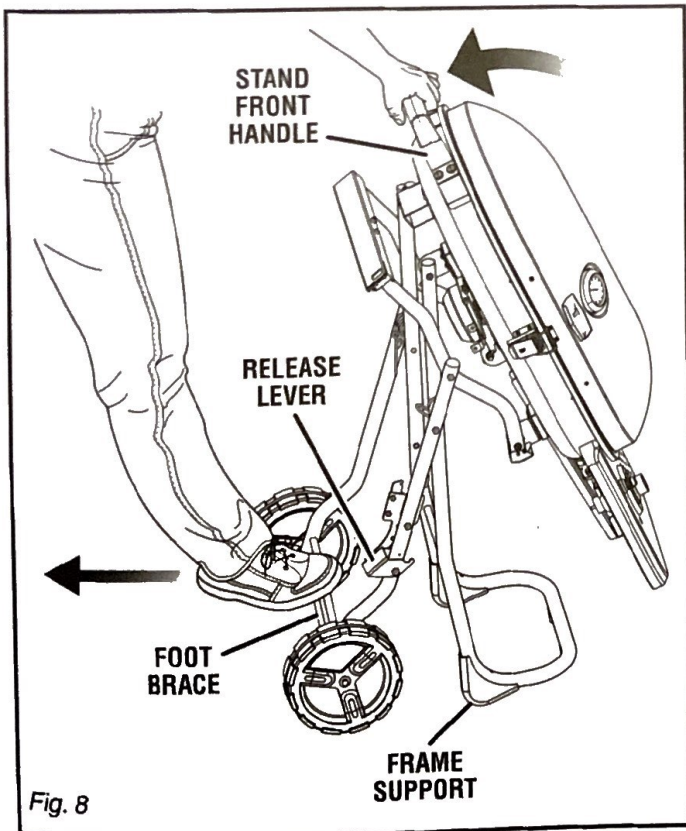

# ASSEMBLY

## STEP 4: ATTACHING FIREBOX HANDLE

See Figures 11 - 12.

- Raise and open the stand.
- Lift the hood latch then raise firebox hood.
- Remove the wing nuts from the studs in the firebox handle.
- Insert studs in firebox handle through holes in firebox hood.
- Install wing nuts and tighten securely.

## STEP 5: INSTALLING THE GREASE CUP

See Figure 13.

- Slide the grease cup into the cup holders on the bottom of the grill.

**NOTE:** Clean the grease cup after each use. Do not remove the grease cup until after the grill has cooled completely. Do not transport the grill with a dirty grease cup.

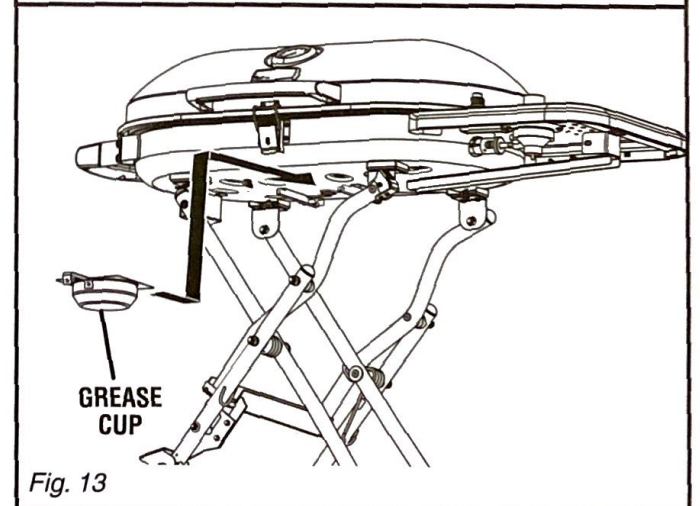
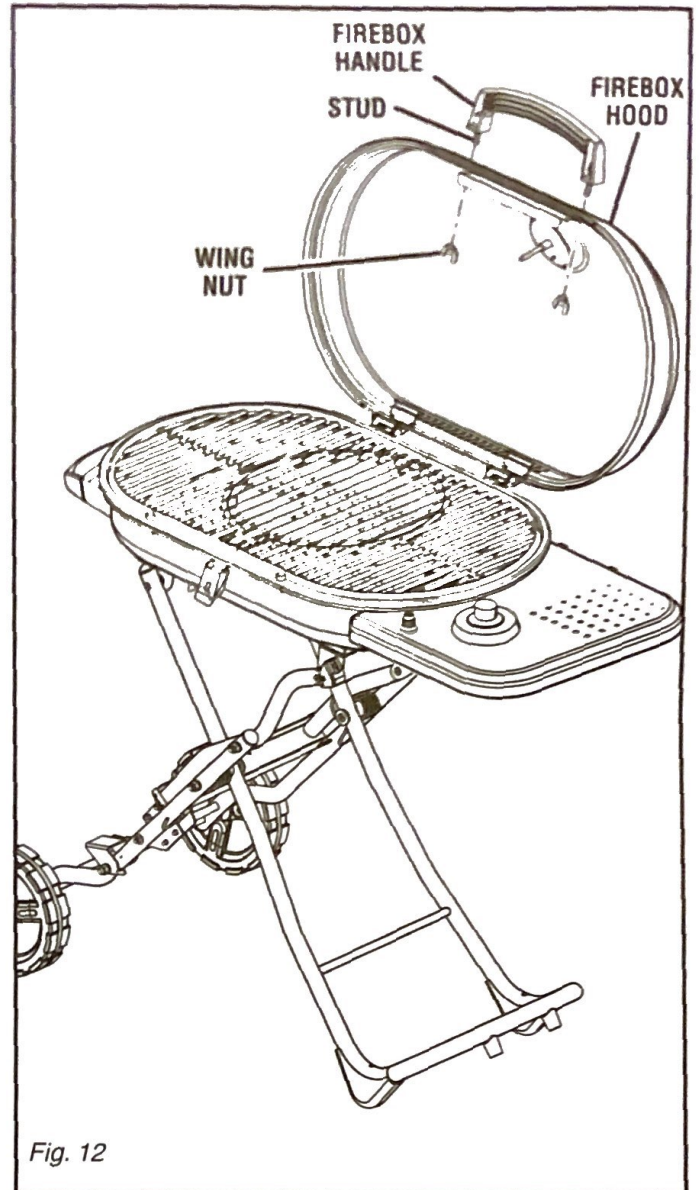
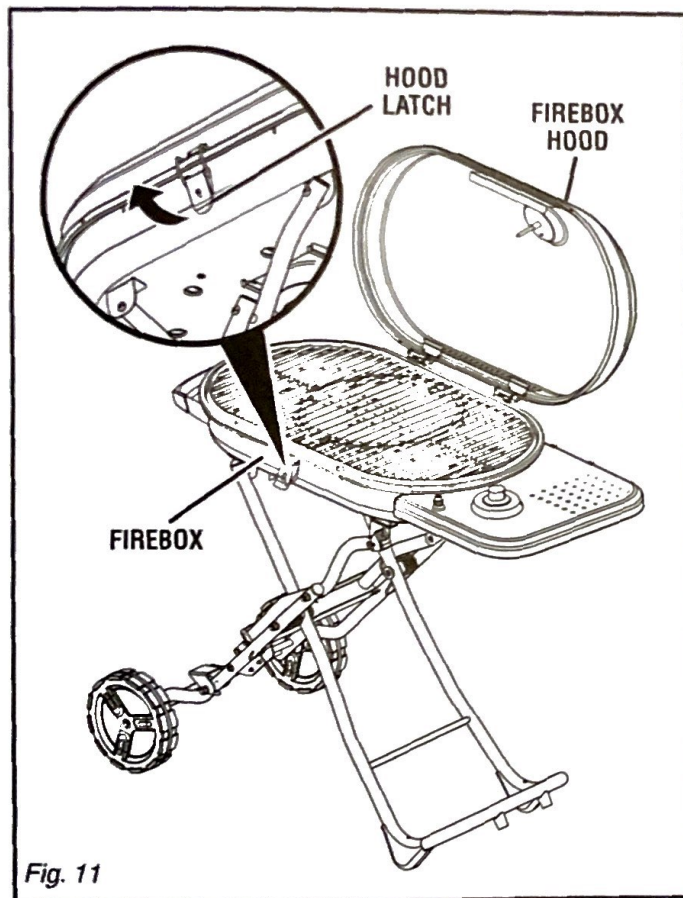



# ASSEMBLY

## STEP 6: INSTALLING BATTERY IN IGNITOR

See Figure 14.

- Turn the ignitor cap counterclockwise and lift cap from the control panel.
- Slide a AAA battery, negative (–) end first, into the ignitor. Be sure spring is still in place inside the ignitor cap.
- Replace ignitor cap

## STEP 7: CONNECTING THE LP GAS CYLINDER TO THE REGULATOR

See Figure 15.

- Remove cap from LP gas cylinder.
- Hold the LP gas cylinder firmly and insert into the regulator.
- Turn the cylinder clockwise taking care not to cross thread the connection. Do not use tools.

**NOTE:** The regulator will seal in the cylinder valve resulting in some resistance. An additional one-half to three-quarters turn is required to complete the connection. If you cannot complete the connection, disconnect and repeat the above two steps. If you still cannot complete the connection, DO NOT use this regulator!

- Inspect valve connections. Look for any damage or debris. Remove any debris. **Never attempt to use damaged or plugged equipment. See your local LP Gas Dealer for repairs.**

## STEP 8: TESTING VALVES AND REGULATOR FOR LEAKS

See Figure 16.

Connections on the valve were tested at the factory to ensure no gas leaks were present. However, shipping and handling could loosen connections. As a safety precaution:

- Turn the control knob off.  
**NOTE:** To lock the control knob in the off position, turn the control knob to LOCK (🔒).
- Make sure the LP cylinder is properly connected to the LP gas cylinder valve.  
If you hear a *rushing* sound, immediately remove the LP gas cylinder. This sound means there is a major leak at the connection. Correct the problem before proceeding.
- Using a clean paint brush and a 50/50 mixture of mild soap and water, brush soapy solution over all the connections and fittings on the grill.
- "Growing" bubbles indicate a leak. Remove the LP gas cylinder and recap the bottle.  
**NOTE:** If leaks cannot be stopped, do not try to repair. Call for replacement parts.

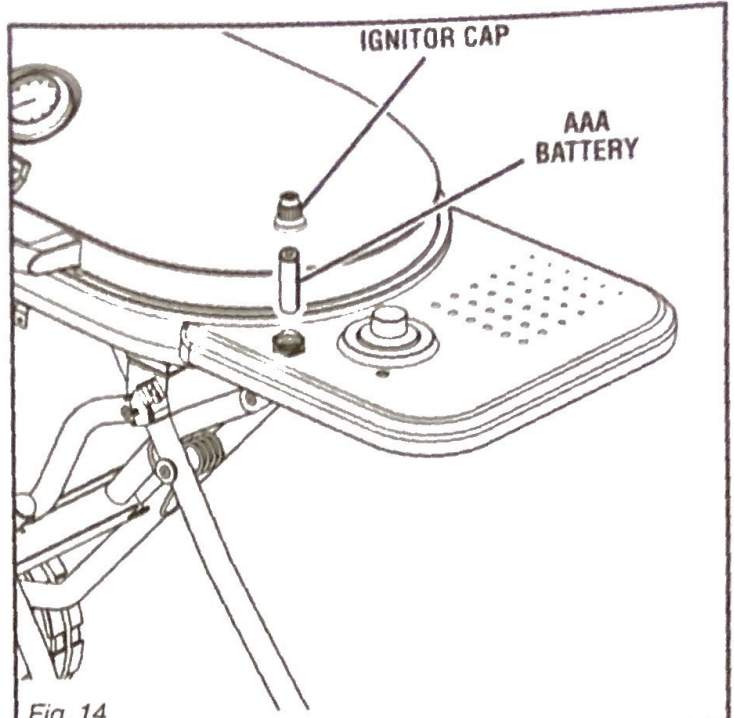

Fig. 14

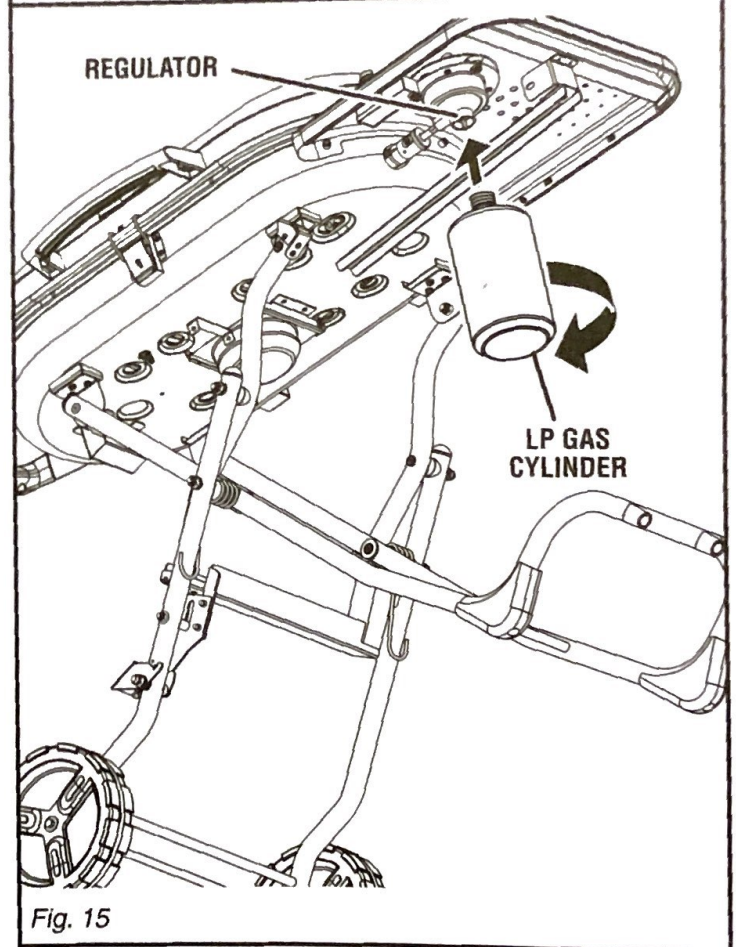

Fig. 15



## ASSEMBLY

### STEP 9: CLOSING STAND AND TRANSPORTING THE GRILL

See Figures 17 - 18.

Never close the stand or attempt to move the grill unless the grill is completely cool, the grease cup is empty, and the LP gas cylinder is removed.

**NOTE:** Make sure the grate and removable insert are in place and hood latch secured prior to closing the stand or transporting the grill. This will help to keep all grates in place.

#### To close the stand:

- Grasp the stand front handle and step on the release lever.
- Lift the stand front handle up and away from you.
- Apply slight forward pressure until the release lever clicks into place and the unit rests on the wheels and frame support.
- From this position, the GridIron™ grill can be moved easily from place to place.

#### To lower a closed stand :

- Stand at the wheel side of the collapsible stand and grasp the stand front handle.
- Tilt the unit toward you and then slowly lower it to the ground.

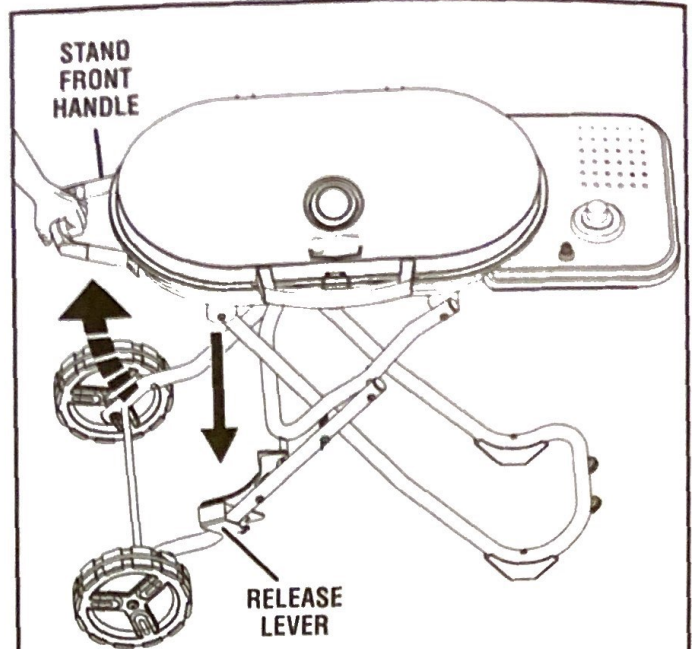
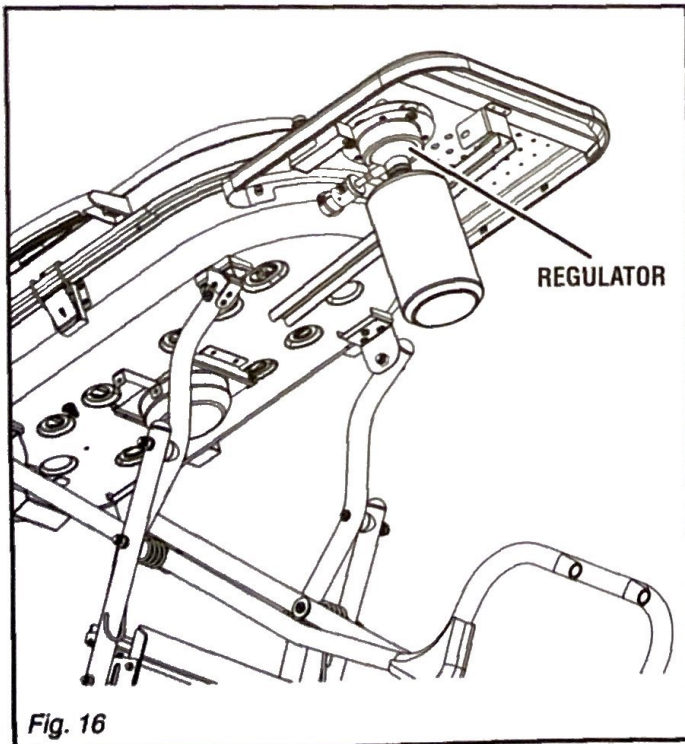

Fig. 17

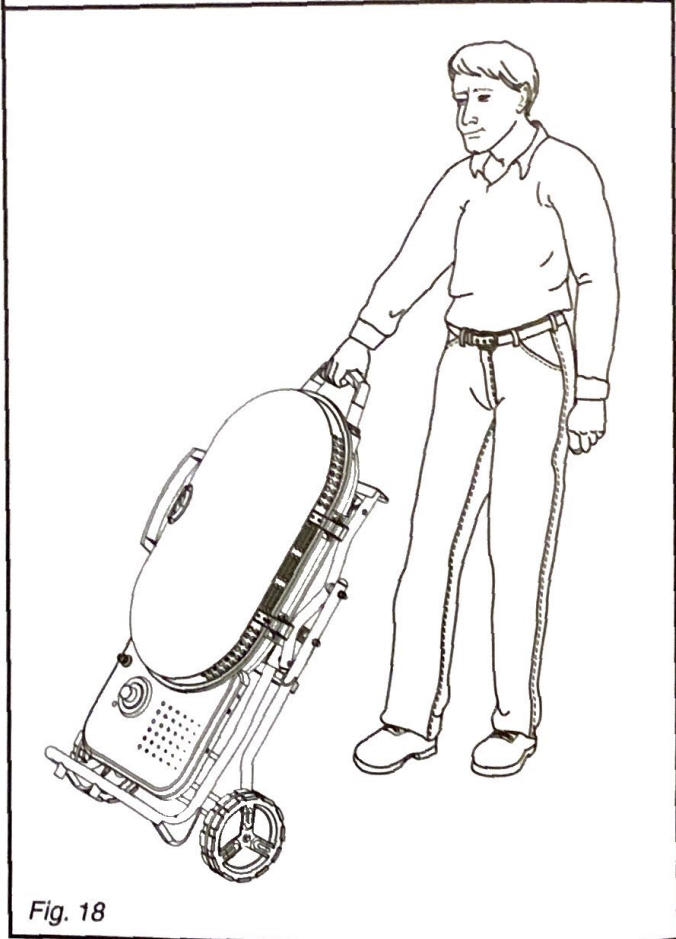

Fig. 18



## OPERATION

### WARNING:

Do not allow familiarity with grill to make you careless. Remember that a careless fraction of a second is sufficient to inflict severe injury.

### WARNING:

Do not use any attachments or accessories not recommended by the manufacturer of this grill. The use of attachments or accessories not recommended can result in serious personal injury.

### SAFETY TIPS FOR USING THE GRILL

- Before turning the control knob on, check the LP gas cylinder for tightness and perform a leak test.
- Trim excess fat from meat to reduce flare ups from drippings.
- When grill is not in use, turn the control knob to LOCK (🔒), and remove the LP gas cylinder.
- Do not move grill while cooking.
- To avoid burns and splatters, use long-handled utensils and oven mitts.
- Do not use the grill if the grease cup is not clean and properly installed.
- Once the grill has cooled, clean promptly.
- Do not let grease or hot material drip from the grill onto the valve, hose, or regulator. Correct the problem before use.
- If the regulator frosts, immediately turn off the grill and cylinder valve. This indicates a problem with the LP gas cylinder and it should not be used. Return the cylinder to the supplier.
- Do not leave the grill unattended while preheating or burning off food residue. If the grill has not been regularly cleaned as instructed, a grease fire can occur.
- Never use water on a grease fire.
- Perform a burner flame check before each use (see the *Maintenance* section).

### GRILLING GUIDE

**High** — for preheating the grill, searing steaks and other cuts of meat, burning off food residue from grate.

**Medium** — for most grilling, baking, and roasting.

**Low** — for cooking fish and other lean foods.

### COOKING/GRILLING TIPS

- The best oils to use when grilling meats are high-temperature oils (i.e., peanut, canola, safflower, and cottonseed oils).
- Dry off meat prior to grilling. Dry meat browns; wet meat steams.
- Grill with the firebox hood down.
- Keep grates clean. A clean grate is less likely to be sticky and will last longer.
- Clean the firebox hood and inside the firebox often. A grease build-up is a fire hazard and adds unwanted flavors to your fresh food.
- Before lighting the burner, spray grates with non-stick spray to prevent food from sticking.
- Always preheat the grill 10 - 15 minutes prior to use.
- Before you start grilling, organize the food by cooking technique, required cooking time, and grilling area required.
- Sauces containing sugars and fats can cause flare-ups and burn your food. Apply these sauces only in the last 10 minutes of cooking.
- Marinades and rubs enhance the flavor of food. A dry rub or liquid marinade can be used prior to cooking.

### FOOD SAFETY

- Wash hands, utensils, and surfaces with hot soapy water before and after handling raw meat.
- Keep raw meat separate from ready-to-eat foods.
- Use a clean platter and utensils when removing cooked food from the grill.
- Cook meat and poultry thoroughly to kill bacteria.
- Use a meat thermometer to ensure proper internal temperature of meat.
- USDA Recommended Safe Minimum Internal Temperatures of Food:
  - 145°F for beef, veal, lamb, steaks, and roast
  - 145°F for fish
  - 160°F for ground pork, beef, veal, and lamb
  - 160°F for pork
  - 160°F for egg dishes
  - 165°F for turkey, chicken, and duck (whole, pieces, and ground)
- Refrigerate prepared and leftover foods promptly.

### WARNING:

If ignition does NOT occur within 5 seconds, turn the control knob to OFF (O) and wait 5 minutes. Repeat lighting procedures. If burner does NOT ignite with the cylinder valve open, gas will continue to flow out of the burner and could accidentally ignite and result in serious personal injury.



# OPERATION

## IGNITING THE BURNER

See Figures 19 - 20.

**NOTE:** Never lean over the grill while lighting burner.

The first time you use your newly purchased grill, it is recommended the grill run on the highest setting for 15 - 20 minutes.

**To ignite burner using the electric ignitor:**

- Open the firebox hood.
- Turn the control knob on the side shelf to OFF (O).  
**NOTE:** To lock the control knob in the off position, turn the control knob to LOCK (🔒).
- Make sure the LP gas cylinder is tightly connected to the regulator and a leak test has been performed.
- To light the burner, push in the control knob and turn to 🔥.
- Press and hold the electric ignitor until the burner lights. When burner is lit, turn the control knob to the desired setting.

If burner fails to light within five (5) seconds, release the electric ignitor. Turn the control knob off and wait five (5) minutes then repeat the step.

**NOTE:** Place burner on high and observe flame height which should be approximately 1/2 in. If the flame is too high or too low, burner adjustment is required. See *Maintenance* section later in this manual.

**NOTE:** If a burner is accidentally extinguished, turn the control knob off, wait five (5) minutes then start the ignition process again.

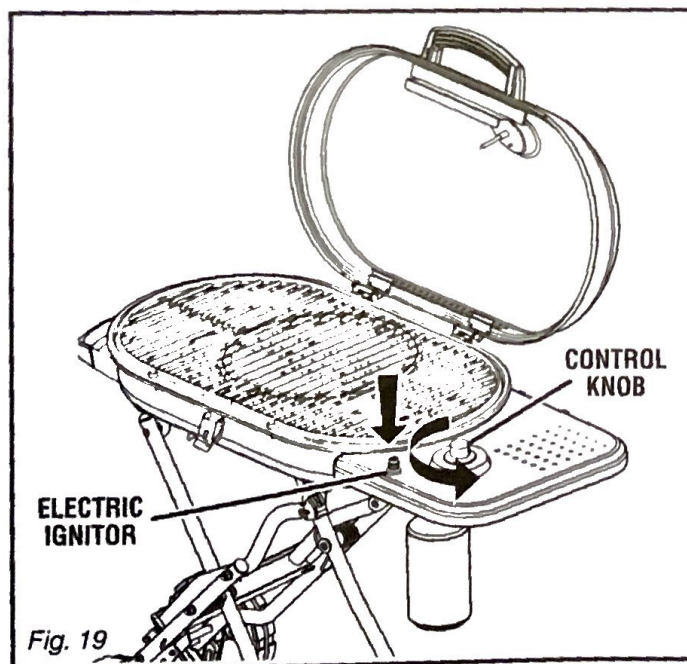

**To ignite burner using match lighting:**

- Open the firebox hood.
- Turn control knob to OFF (O).  
**NOTE:** To lock the control knob in the off position, turn the control knob to LOCK (🔒).
- Make sure the LP gas cylinder is tightly connected to the regulator and a leak test has been performed.
- Using the match holder included with this grill, place a match between the circular wires.
- Light the match and place into lighting hole on the bottom of the firebox.
- Push in the control knob and turn to 🔥.
- When burner is lit, turn the control knob to the desired setting.

If burner fails to light, extinguish the match, turn the control knob off, and wait five (5) minutes then repeat the step.

**NOTE:** Place burner on high and observe flame height which should be approximately 1/2 in. If flame is too high or too low, burner adjustment is required. See the *Maintenance* section later in this manual.

**NOTE:** If a burner is accidentally extinguished, turn the control knob off, wait five (5) minutes then start the ignition process again.

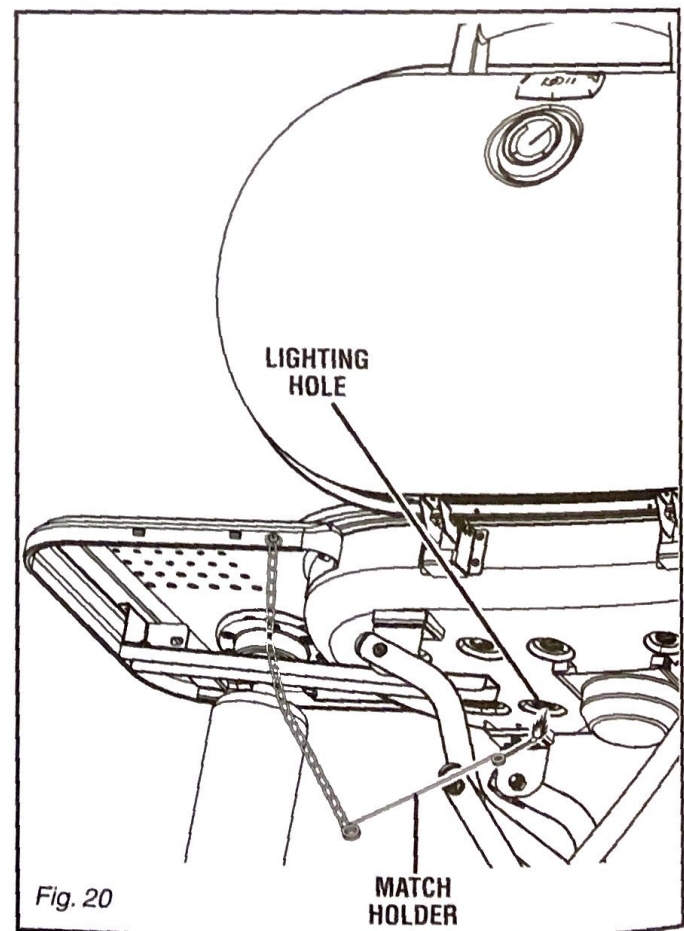



## OPERATION

### USING THE GRILL AND ACCESSORIES



#### WARNING:

Never use an accessory if the porcelain coating is damaged or chipped. Use with a damaged coating could result in serious personal injury if ingested.

#### WARNING:

Remove grate insert from cold grill or use heat-resistant mitts if removing a hot insert. Place insert on a heat resistant surface and keep away from children. Removing a hot insert may result in possible serious injury.

#### To use the grate:

-  Turn on the grill and close the firebox hood. Preheat the grill for 10 - 15 minutes.
-  Open the firebox hood and place the food on clean grates then close the firebox hood. Cooking time will vary depending on personal preference.

**NOTE:** When grilling fish, the meat is typically done when it flakes easily with a fork. If any part of the meat is glossy in appearance, it is not done.

-  When finished cooking, turn the control knob off.

**NOTE:** To lock the control knob in the off position, turn the control knob to LOCK (🔒).

-  After the grill has cooled, clean grates and grease cup.

## MAINTENANCE

### **⚠ WARNING:**

When servicing, use only identical replacement parts. Use of any other parts could create a hazard or cause product damage.

### GENERAL MAINTENANCE

When cleaning the inside of the firebox hood and grill bottom, use a strong solution of detergent and water with a scrub brush to clean. Rinse thoroughly and allow to air dry. NEVER use a caustic grill cleaner on painted or cooking surfaces.

All plastic parts, stainless-steel and painted surfaces, should be cleaned with warm soapy water and wiped dry. Cooking surfaces should be cleaned with a bristle brush only. Check that no loose bristles remain on the cooking grates prior to using.

#### Cooking grates:

- Clean before and after each use with a stiff wire brush.

#### Port shields:

- Scrape any build-up off the port shields using a wire brush.

#### Grease:

- After use, allow the grease in the cup to cool then empty into the garbage.
- Empty after each use to avoid spillage and flare ups.

### CLEANING BURNER ASSEMBLY AND CHECKING VENTURI FOR INSECTS

See Figures 21 - 22.

### **⚠ DANGER:**

Failure to clean the burner assembly and check the venturi as described can result in a fire or explosion resulting in serious injury or death.

Burner should be cleaned when the grill has been idle for some time. In some parts of the country, spiders and other insects can spin webs, build nests, and lay eggs in the venturi blocking gas flow and causing fire in the tubes known as "flashback". Flashback can damage the grill and even cause injury.

- Turn control knob to OFF (O). Allow grill to cool completely.  
**NOTE:** To lock the control knob in the off position, turn the control knob to LOCK (🔒).
- Remove the LP gas cylinder.
- Pull electrode wire from the electronic ignitor.
- Remove the wing nuts securing the burner to the firebox.
- Using work gloves, lift burner up and away from the gas valve openings.

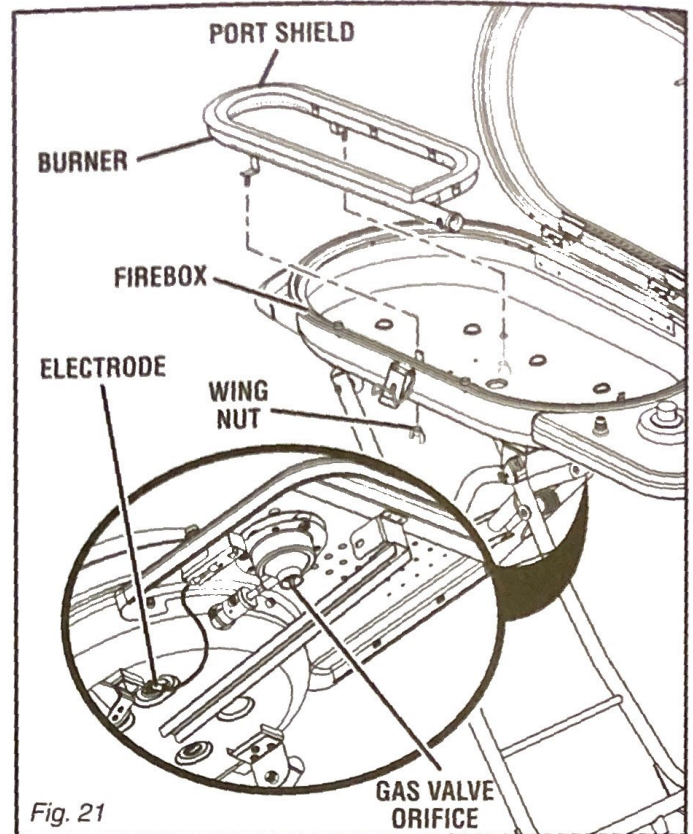

Fig. 21

#### Clean burner tubes using one of the following three ways:

1. Bend a stiff wire into a small hook. Run the hook through the burner tube several times.



2. Use a narrow bottle brush with flexible handle and run through burner tubes several times. DO NOT use a wire brush.
3. Wear eye protection then use an air hose to force air into the burner tube and out through the burner port. Clean any clogged port with an opened paper clip.

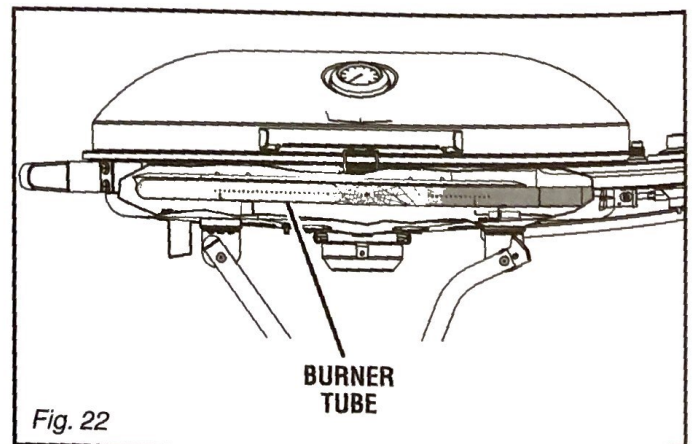

Fig. 22



## MAINTENANCE

- Once burner tube is clear of debris, use a wire brush to remove food and dirt from the outer surface of the tubes.
- Check burner for damage. Normal wear and corrosion may cause some holes to enlarge. Replace burner if this happens.

**NOTE:** Burner tube must reengage valve opening.

- Verify that the gas valve orifice is correctly positioned inside burner inlet.
- Attach the electrode to the burner and carefully replace the burner.
- Slide burner into the grill and secure burner using wing nuts.
- Reattach electrode wires to the electric ignitor.

### BURNER FLAME CHECK

See Figure 23.

- Open the firebox hood and allow grill to cool completely.
- Turn control knob to OFF (O).

**NOTE:** To lock the control knob in the off position, turn the control knob to LOCK (🔒).

- Remove grates.
- Light burner and turn the control knob from high to low. A smaller flame should be seen on low while the high positions flame should be approximately 1/2 in. in height.
- If only a low flame is seen, you may need to replace the LP gas cylinder.

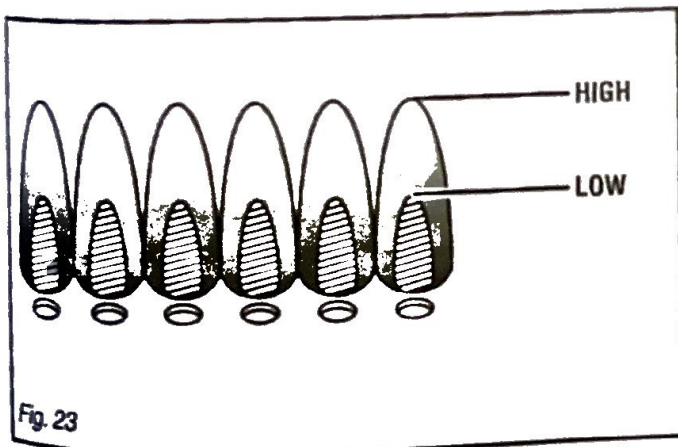

Fig. 23

### IGNITOR CHECK

Remove LP gas cylinder completely. Press and hold the ignitor. "Click" should be heard and a spark seen between the burner and electrode. If no spark, see the *Troubleshooting* section later in this manual.

### VALVE CHECK

Remove LP gas cylinder completely. Control knob locks in place when turned off. To check valves: push in knobs and release. If knobs don't spring back, replace the valve assembly before using grill.

### STORING THE GRILL

See Figure 24.

- Turn the control knob to OFF (O).

**NOTE:** To lock the control knob in the off position, turn the control knob to LOCK (🔒).

- Remove LP gas cylinder.
- Place dust cap on cylinder valve outlet whenever the cylinder is not in use. Only install the type of dust cap on the cylinder valve outlet that is provided with the cylinder valve. Other types of caps or plugs may result in leakage of propane.
- Once cooled, clean grill thoroughly, including grease cup.

## TROUBLESHOOTING

PROBLEM	POSSIBLE CAUSE	SOLUTION
Smell of gas	Regulator, or valve leaking.	Remove LP cylinder immediately and check for damaged regulator or valve. Perform leak test, see <b>Testing Valves and Regulator for Leaks</b> in the <i>Assembly</i> section.
Flame flashback beneath control panel	Fire in burner tube due to blockage.	See <b>Cleaning Burner Assembly and Checking Venturi for Insects</b> in the <i>Maintenance</i> section.
Gas leak detected from cylinder, regulator, or other connection	Improper installation and loose connections.  Mechanical failure due to rusting or mishandling.	Tighten fittings and see <b>Testing Valves and Regulator for Leaks</b> in the <i>Assembly</i> section.  Replace LP gas cylinder.
Grease fire or continuous excessive flames above cooking surface	Grease build up in burner area.	Turn off control knob. Leave firebox hood open allowing flames to extinguish. Once cool, clean grill thoroughly.
Burner will not light	LP gas cylinder is empty. Burner not connected to control knob.  Venturi blocked.  Ignitor wire is loose, dirty, or not connected.  Dead battery in ignitor.	Replace LP gas cylinder. Make sure valves are inside the burner tubes. See <b>Testing Valves and Regulator for Leaks</b> in the <i>Assembly</i> section. Reconnect burner electrode wires or replace the ignitor wire assembly. Clean wires and/or electrode with rubbing alcohol and a clean swab. Tighten all connections. Replace the battery in the ignitor.
Decreasing heat or popping sound	LP gas cylinder is empty. Venturi blocked.	Replace LP gas cylinder. See <b>Cleaning Burner Assembly and Checking Venturi for Insects</b> in the <i>Maintenance</i> section
Hot spots on cooking surface	Venturi blocked.	See <b>Cleaning Burner Assembly and Checking Venturi for Insects</b> in the <i>Maintenance</i> section
Yellow flame	Venturi or burner may be blocked.	See <b>Cleaning Burner Assembly and Checking Venturi for Insects</b> in the <i>Maintenance</i> section
Inside of firebox hood appears to be peeling	This is a build up of grease.	Clean with a soft bristle brush or scraper.



## WARRANTY

Dong Fang Jun Ma Trade Co., Ltd. (hereafter, DFJM) warrants that this Product shall be free from defects in workmanship and materials, for a period of 1 Year from the date of original purchase. Our obligation under this warranty shall be limited to replacement of parts during the warranty period. Our liability shall not extend beyond replacement of parts. This warranty excludes normal wear & tear such as paint loss, discoloration and rust on the product and its parts or components, and any damage arising from any of the following: negligent use or misuse of the Product, use contrary to this User's Manual, or alteration by any one other than DFJM. All warranty coverage is void if this grill is ever used for commercial or rental purposes; this warranty is valid only in the USA. The warranty period of 1 year shall not be extended or renewed by the repair or replacement of parts or compensation for the Product. If your Product is defective or otherwise requires service or parts, please call DFJM Customer Service toll-free at MONDAY TO FRIDAY, between 8:30 a.m. and 4:30 p.m. CST. Consumer is responsible for shipping, handling and processing of warranty claims after 30 days of purchase date. As proof of purchase, a copy of your original purchase receipt must accompany any service request.

## LIMITATION OF REMEDIES AND LIABILITY

We shall not be liable for any incidental or consequential damages for breach of any express or implied warranty on its product. Except to the extent prohibited by applicable law, any implied warranty or merchantability or fitness for a particular purpose on this Product shall be limited to the duration of the above warranty. Neither us nor anyone else who has been involved in the creation, production, or delivery of the product shall be liable for damages of any type, including but not limited to any lost profits, lost savings, loss of anticipated benefits, or other incidental or consequential damages which may arise out of the purchase, use, or inability to use the product, whether arising out of contract, negligence, strict tort, or under any warranty, or otherwise, even if you have been advised of the possibility of such damage or any other claim by any other party. Our liability for any breach of warranty shall be limited to repair or replacement of the defective part or parts as described above. Some states do not allow the exclusion or limitation of incidental or consequential damages, so the above limitation or exclusion may not apply to you. The above warranty gives you specific legal rights, and you may have other rights which vary from state to state.

Thank you for purchasing this product! If you have questions about the assembly or operation of this product, any missing parts, or have defective parts, please e-mail us at:

**customerservice@dongfangjm.com**

Or, call us toll free (M-F 8:30am to 4:30pm Central Time) at:

**1-866-273-2284**

Manufactured by:  
Dong Fang Jun Ma  
**MADE IN CHINA**