

Vespa® Official Product

Children Four-Wheel Battery Operated Car

GUIDE BOOK

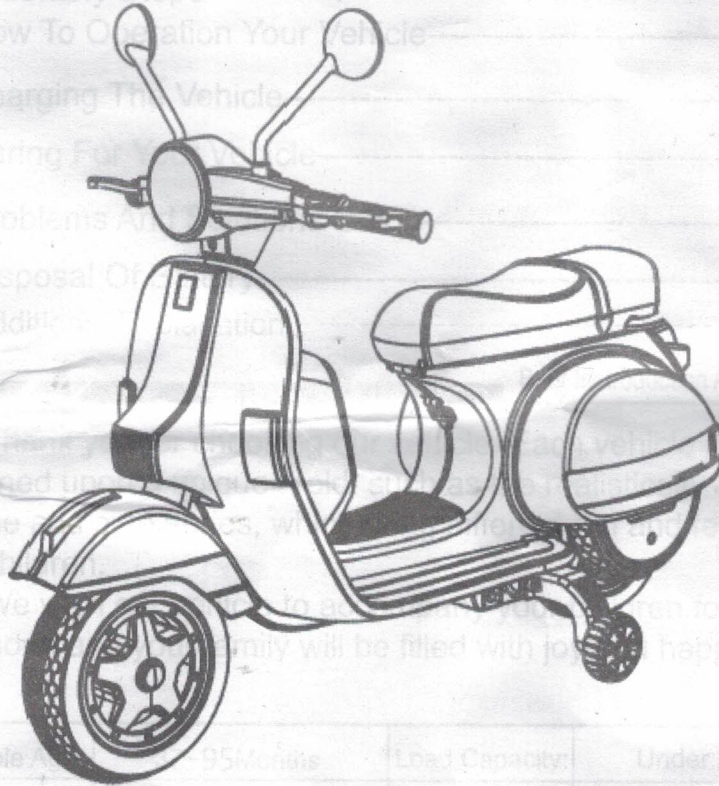

4 Battery Life 06
5 Assembly Steps 06
6 How To Operation Your Vehicle 06
7 Charging The Vehicle 09
8 Caring For The Vehicle 09
9 Problems And Solutions 09
10 Disposal Of The Vehicle 11
11 Additional Information 11

Suitable	95Months	Load Capacity	Under 25KGS
Motor	"Vespa® is a registered trademark owned by Piaggio & C.S.P.A. and used under license by shanghai Happy Children Factory"		
Case	12V-4 Ah		
Average	Approximate		

The car must assembled by adults. Picture only for your reference, products features may vary from the pictures in book, configuration based on your order!

CHOKING HAZARD--Small parts, it is not for children under 3 years!

Please read the operating instuctions carefully before using.

1 Brief Introduction And Models-----	01
2 Important Safety Instructions-----	02
3 Parts List-----	04
4 Battery Line Connector -----	05
5 Assembly Steps-----	06
6 How To Operation Your Vehicle-----	08
7 Charging The Vehicle-----	09
8 Caring For Your Vehicle-----	09
9 Problems And Solutions Guide-----	09
10 Disposal Of Battery-----	11
11 Additional Explanation -----	11

 Brief Introduction And Models

Thank you for choosing our vehicle. Each vehicle pattern is designed upon a unique mold: such as the realistically imitated vehicle and cute series, which bring different fun and feeling for your children.

We wish our vehicle to accompany your children for a happy childhood and your family will be filled with joy and happiness.

Suitable Age:	37~95Months	Load Capacity:	Under 25KGS
Motor	RS390/12V/13000RMP	Size Of Car:	107*51*82CM
Charger:	Input:110 or 220V 50HZ Output: DC12V 700MA	Battery:	12 V-4.5Ah or 12 V-7Ah
Power Way:	Charging Type	Charging Time:	8-12 Hours
Fuse:	7A	Average Battery Life:	Approximately 300 Times

Manual book only for your reference, all configuration based on your order!

Read carefully and follow all the instructions

⚠ WARNING ! CAUTION

Assembly/Used

⚠ Product requires adult assembly.

- ⚠ parts, sharp edges and sharp points in the vehicle's unassembled state.
- ⚠ Care should be taken in unpacking and assembly of the vehicle.
- ⚠ Children should not handle parts, or help in assembly of the vehicle.
- ⚠ Small assembling parts have choking danger, forbidden to children's play.
- ⚠ This product is forbidden to children under 3 years.
- ⚠ Always properly handled the protective material and poly bags before assembly. Forbidden to children's play and have suffocation danger!
- ⚠ Suitable for age 37~95 months; Maximum user weight is 25 Kgs.
- ⚠ **Direct Adult Supervision Required** Never leave child unattended by himself.
- ⚠ Always keep child in view when he is in vehicle. Teach safety rules to your child before allowing operation of this vehicle. These rules should also be reviewed with other playmates who want to drive this vehicle. Make sure children know and follow these rules for safe driving and riding:
 - Always wear shoes.

- Always sit on the seat with safety belt.

- Always wear a helmet when riding. Only one rider at a time.

⚠ Keep children within safe riding areas, these areas must be:

- Warning. Not to be used in traffic. Away from steps/cars/driveways /roads and alleys.
- Away from sloped/inclined surfaces/swimming pools or other wet place.
- Away from other dangerous places.
- Only outdoors. Generally flat ground/playground and other hard surfaces.
- Play in daytime, avoiding in rainy or dark day, or maybe occur danger.

⚠ Warning. This toy has no brake. Before using, adult should check the main components whether the car whether in good condition:

Battery plug should be plugged in, power is switched; battery/charge/wire/plug/car body and other parts whether is damage; whether screw loose; whether have another damage problems.

To avoid using damaged car until it repaired.

! The toy should be used with caution since skill is required to avoid falls or collisions causing injury to the user or third parties.

! To avoid demaging the motors and gears, stop the vehicle before shifting from forward to backward switch.

! Please turn forward/stop/backward switch to "O" in the state of no-driving.

Turn off power switch. (notice: this switch only control the parts of drive.)

- ! Do not let any child touch the wheels or near them when the car is moving.
- ! Do not tow anything behind the vehicle or overload it, do not exceed the maximum weight capacity of 25 kgs.



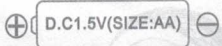
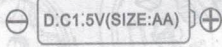

Battery/Charger/Alkaline Batteries

- ! The battery/ charge/ alkaline batteries are not toy, forbidden for children playing.
- ! Non-rechargeable batteries are not to be recharged.
- ! Do not mix old and new batteries or batteries of different types: alkaline, standard (carbon-zinc) or rechargeable (nickel-cadmium).
- ! Battery charging must be done by adults only.
- ! Insert batteries are correct polarity inside the battery compartment. (Like the picture)
- ! Remove exhausted batteries from the product. 
- ! Remove batteries during long periods of non-use. 
- ! Never short-circuit the battery terminals.
- ! Use only with manufacturers prescribed rechargeable battery and charger.
- ! Do not use the battery or charger for any other product. Could cause overheating, fire or explosion.
- ! Do not open the battery and the charger
- ! Do not charge battery upside down.
- ! Always maintain battery dry. Do not let the vehicle contact fresh water or salt water.

Charge

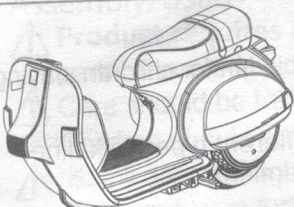
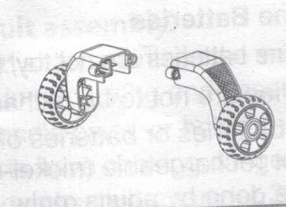
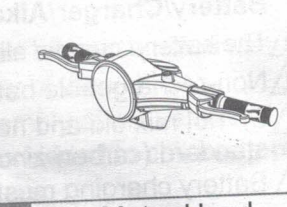
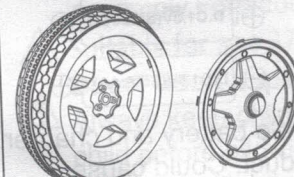
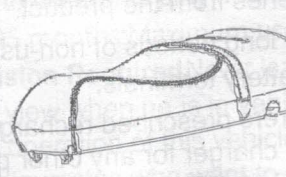
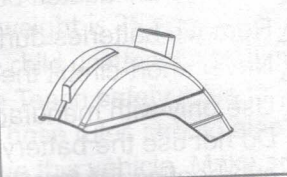
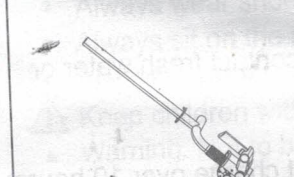
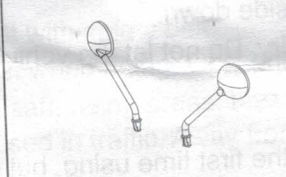
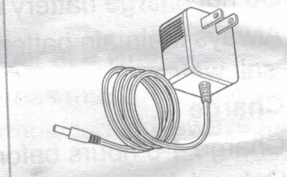
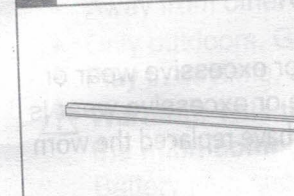
- ! Charge 4-6 hours before the first time using, but not charge over 10 hours.
- ! Only adult can handle or charge the battery. Never allow children to do that. Turn off power switch before charge the battery.
- ! Connecting correct polarity when charging.
- ! Examine the battery, charger and their connectors for excessive wear or damage each time you charge the battery. If damage or excessive wear is detected, do not use the charge or the battery until you have replaced the worn or damaged parts.
- ! When the vehicle's normal speed apparent slow down or after each use, recharge the battery for 8-12 hours, never charge the battery longer than 18 hours.
- ! Charge the battery in a dry area ONLY.
- ! It is normal that charger and battery are tepid while charging.
- ! Charge the battery at least three months one time, even if the vehicle has not been used.
- ! In room temperature below 5 degrees centigrade, charging the actual to lengthen 3-5 hours. Below -5 Celsius please do not use this product.

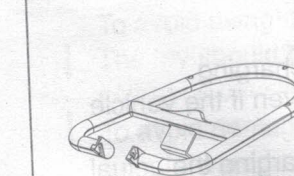
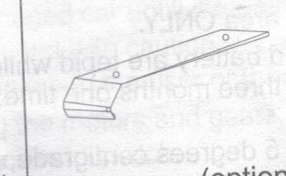
Please identify all parts before assembly and save all packaging materials until assembly is complete.

		
<p>1 Main Body</p>	<p>2 Side Wheels</p>	<p>3 Motor Head</p>
		
<p>4 Front Wheel and Cup</p>	<p>5 Seat</p>	<p>6 Fender</p>
		
<p>7 Steering Shaft Assembly</p>	<p>8 Mirror</p>	<p>9 Charger</p>
		
<p>10 Square Tube</p>	<p>11 Manual Book</p>	
 <p>(optional)</p>	 <p>(optional)</p>	 <p>(optional)</p>
<p>13 Back Support</p>	<p>14 Iron Sheet</p>	<p>15 Tool Box</p>

Connecting and Battery Line

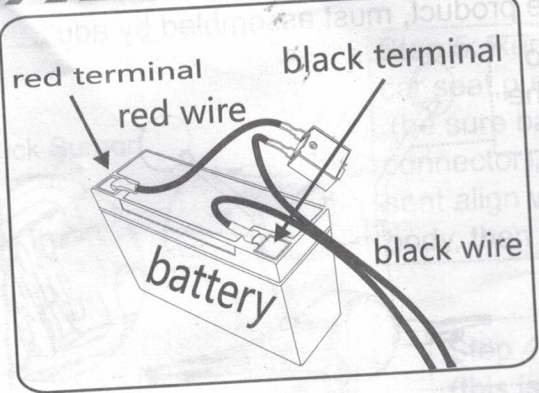

Inserting red wire on the car into red column on the battery.
Inserting black wire on the car into black column on the battery.
(Avoiding inserting into the uncorrect polarity)

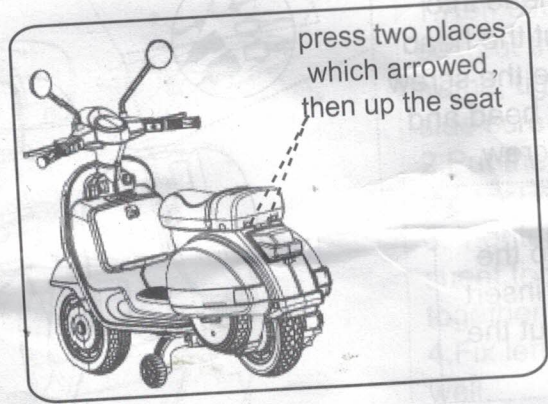

Please note before using the product, must assembled by adult.

Step 6: Press the mirror to the left and right holes in the handlebar.

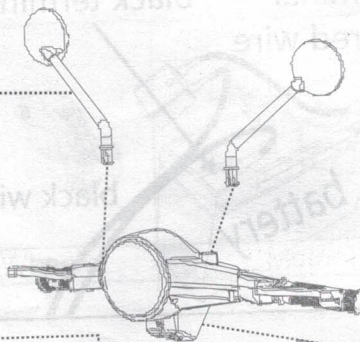

Step 3: Remove the screw out firstly, then insert the line of car head into the line of the car body, put the head in the round pipe and make the screw through the hole of the car head and the pipe hole, tighten the screw.

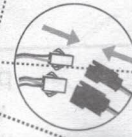

Step 2: Insert the fender into the fork pipe, until the fork pipe insert the car head bottom, then put the car body stability.

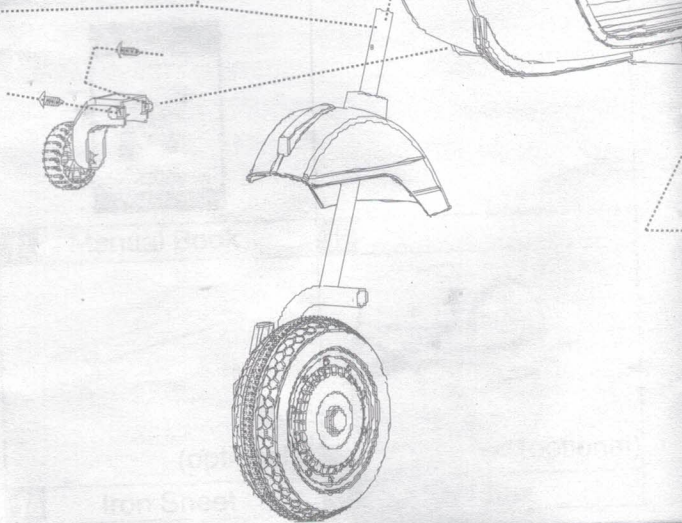

Back Support

Iron Sheet

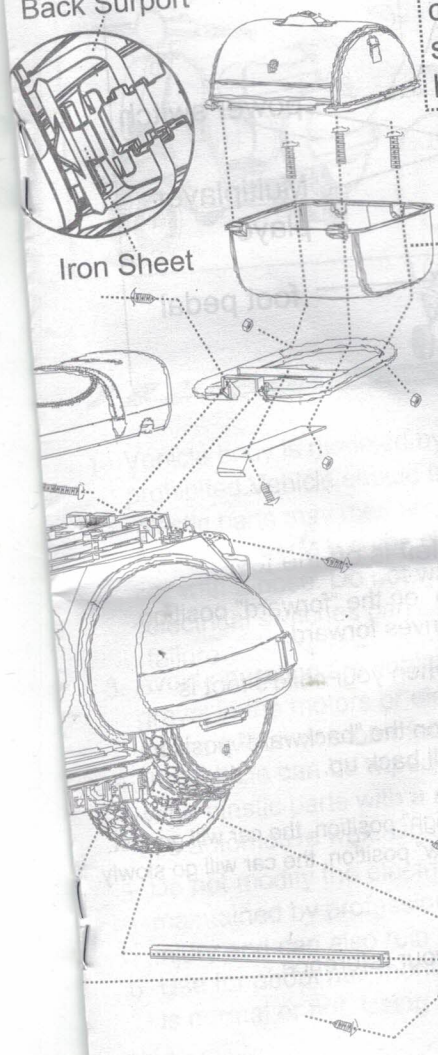

Step 5: Remove the screw from the car seat, put the seat on the car body (be sure battery line already connector), make two holes of the car seat align with two holes of the car body, then tighten the screw.

Step 4: Assemble the car tool box (this is option depend on your order)

1. Remove the screw from the tool box, put the under cover to the tool frame, tighten the left and right side screws.
2. Put the tool box iron sheet under the tool box.
3. Tighten the screw the iron sheet, tool box frame and tool box together.
4. Fix left and right side two screws well.
5. Insert the upper cover to the under cover, align the groove.

Step 1: Pass the square pipe through the body, then two sides put the side wheels and tighten two screws to fix on the side wheels.



Assembly Steps

Please note before using the product, must assembled by adult.

Step 6: Press the mirror to the left and right holes in the handlebar.

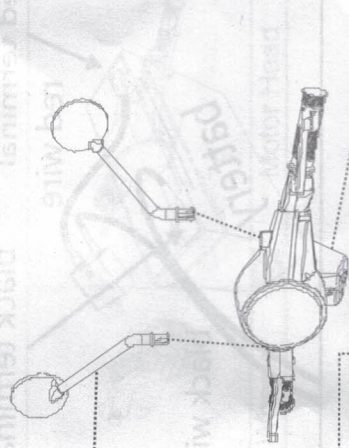

Step 3: Remove the screw out firstly, then insert the line of car head into the line of the car body, put the head in the round pipe and make the screw through the hole of the car head and the pipe hole, tighten the screw.

Step 2: Insert the screw into the fork pipe, until the fork pipe insert the car head bottom, then put the car body stability.

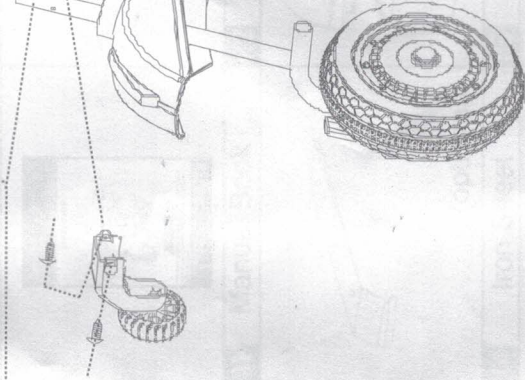

Assembly Steps

Step 5: Remove the screw from the car seat, put the seat on the car body (be sure battery line already connector), make two holes of the car seat align with two holes of the car body, then tighten the screw.

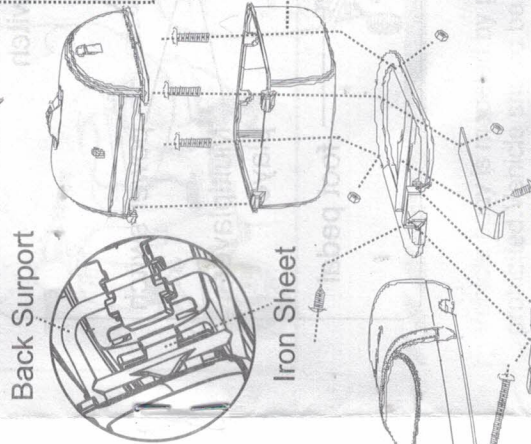

Step 4: Assemble the car tool box (this is option depend on your order)

1. Remove the screw from the tool box, put the under cover to the tool frame, tighten the left and right side screws.
2. Put the tool box iron sheet under the tool box.
3. Tighten the screw the iron sheet, tool box frame and tool box together.
4. Fix left and right side two screws well.
5. Insert the upper cover to the under cover, align the groove.

Step 1: Pass the square pipe through the body. then two sides put the side wheels and tighten two screws to fix on the side wheels.

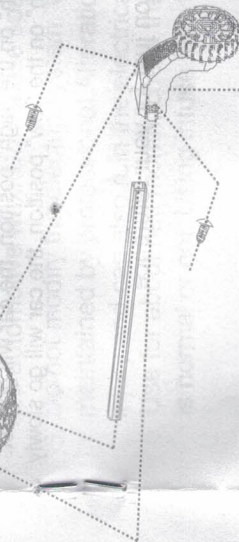

Note! 1.when changing the tap position, please make sure the vehicle hasr. completely stopped, otherwise it will damage the gear box and moto

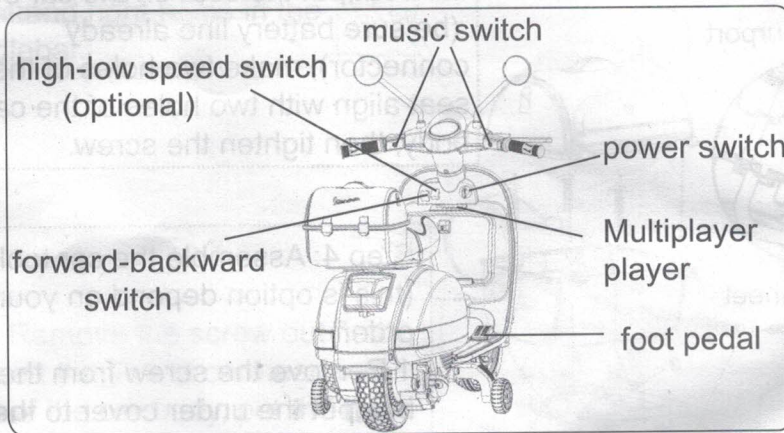

All switches are in the front of the vehicle seat.

Power switch turn right is open the toy, turn left is off the toy.

- **Forward** 1.Press the "forward-backward switch" on the "forward" position.
2.Press the "foot pedal", the vehicle drives forward.
- **Stop** The vehicle will brake automatically, when your child's foot is lifted from the "foot pedal".
- **Back Up** 1.Press the "forward-backward switch" on the "backward" position.
2.Press the "foot pedal", the vehicle will back up..
- **High-low Speed** Press the "high-low speed switch" on the "high" position, the car will go fast.
Press the "high-low speed switch" on the "low" position, the car will go slowly.

Pls note for high-low speed and mp3 fuction just for your reference, all configuration depend on your order!

 **Do not close to the ear, improper use can cause hearing damage.**

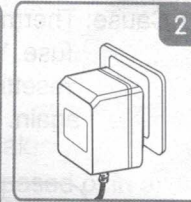
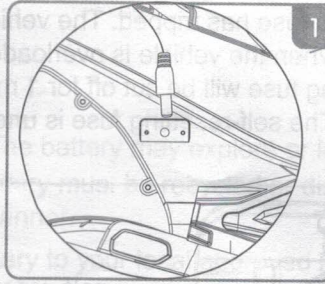
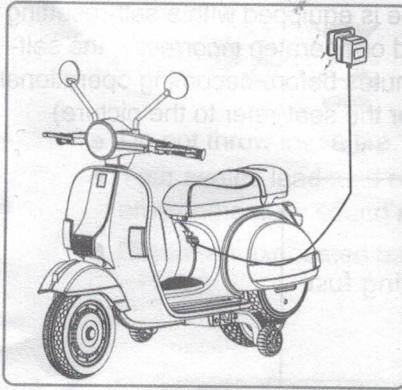

1. Open the charger cover
2. Plug the charger port into the input socket.
3. Plug the charger plug into a wall outlet
The battery will begin charging.

Caring For Your Vehicle

1. Vehicle body is modeled by polypropylene. Solarize or in -15°C use are strictly prohibited. Vehicle should be far away from hot objects, like an oven and heater, plastic parts may melt beside.
2. Avoid operating the vehicle in wet or snowy conditions, and do not spray the car with a hose. Do not wash the vehicle with soap and water. Wet motors or electrical switches can cause them to corrode and can cause switch or motor failure.
3. Avoid operating the vehicle on sand, loose dirt or gravel. Sand, loose dirt or gravel in the motors or electrical switches can cause them to jam, and could cause switch or motor failure.
4. The vehicle can be wiped down with a soft, dry cloth for a shiny finish, you can wipe plastic parts with a non-wax furniture polish applied to a soft-cloth. Do not use automotive wax. Do not use soap or water or spray the vehicle with a hose.
5. Do not modify the electric system. When the fault appears and they must be maintained by professional. Alterations could cause a fire resulting in serious injury and can also ruin the electrical system.
6. Use for about half month, check the wheels turning agilely or not, motor work is normal or not. Using infuse lube to lubricate moving parts.

Problems and Solutions Guide

Problem The vehicle does not run

- Cause: The battery may low on power.
After each use and once a month minimum, charge the battery for 8-12 hour
Do not charge over 18 hour.

- Cause: Thermal fuse has tripped. The vehicle is equipped with a self-resetting fuse. When the vehicle is overloaded or operated incorrectly, the self-resetting fuse will be cut off for 1 minutes before becoming operational again. The self-resetting fuse is under the seat(refer to the picture)

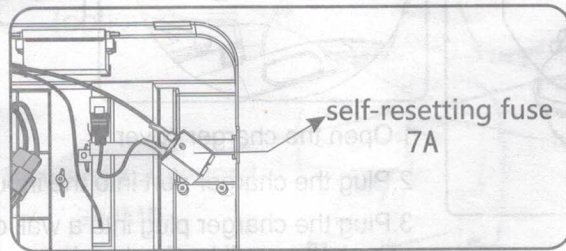

- Cause: battery connector or wires are loose
Make sure the battery connectors are firmly plugged in to each other.
- Cause: battery is dead
Please contact retailer or manufacturer.
- Cause: electric system is damaged
Please contact retailer or manufacturer.
- Cause: motor is damaged
The motor needs professional repair. Please contact retailer or manufacture

Problem: The battery will not recharge

- Cause: battery connector or adapter connector is loose.
Make sure the battery connector and adaptor are firmly plugged together
- Cause: charger is not plugged in.
Make sure the charger is plugged into the wall outlet and the power flow to the outlet is on.
- Cause: charger is not working
Is the charger warm while charging? If not, the charger may be broken and please connect retailer and manufacturer.

Problem: The vehicle does not run very long

- Cause: battery may be undercharged
You may not be charging the battery long enough. After each use, or once a month minimum, charge the battery for 8-12 hour. Do not charge over 18 hour.



- Do not throw into a fire. The battery may explore or leak.
- Your sealed lead-acid battery must be recycled or disposed of in an environmentally sound manner.
- Return an exhausted battery to your local approved lead-acid battery recycle.

 WARNINGS

1. The product is not a transport, do not drive on the street, using the product under adult's guardianship.
2. Do not allow children under 36 months use the product.
3. Overage and overload are forbidden. Maximum load: 25KG.
4. The car should be assembled and checked by adults, guarantee safety before using.
5. Do not wash the product with water, wiping the car using a soft wet cloth only.
6. Battery charging should be handled by adult only, the charging is not toy, do not let children play the charger.
7. Driving on public avenue, street, slope, pool side, stair head and other danger area are strictly forbidden.
8. Do not use this product in high-voltage line, transformer station, gas station, hospital.
9. Must use this product with shoes, with safe-belt.
10. Please read carefully and keep this manual book for your children's safety.
11. In order to prevent a child from suffocation, keep plastic bags away from children.

Operative norm: EN71-1
EN71-3

EN71-2
EN62115

The illustration adopted in the explanation is used for explaining product's operating measures and configuration. When there is little difference between assembly diagram and practicality, according to the real object please.

Improvement in vehicle will be added to the manual of new edition, there is no extra information. The company reserves the right to change the manual of its models at any time.

At least, thank you for purchasing our products. We will provide you with comprehensive services wholeheartedly. May your family live a happy life and your baby grow up happily.