



1691050

# 6 Cubic Feet

## Poly Tub Wheelbarrow INSTRUCTION MANUAL



Max. Carry capacity for light goods: 6 cu. ft./0.17 cu. m.

Max. Carry capacity for loading: 300lbs/136kgs

Max. Carry capacity for liquid: 106qt/ 100l

**CAUTION:** Never inflate tire above 30PSI(206Kpa)

### IMPORTANT INFORMATION:

Read all instructions prior to assembly.

For ease of assembly, it is recommended that 2 people assemble the wheelbarrow.

Prior to assembly, lay out all parts on a flat, non-abrasive surface and verify that there are no pieces missing.



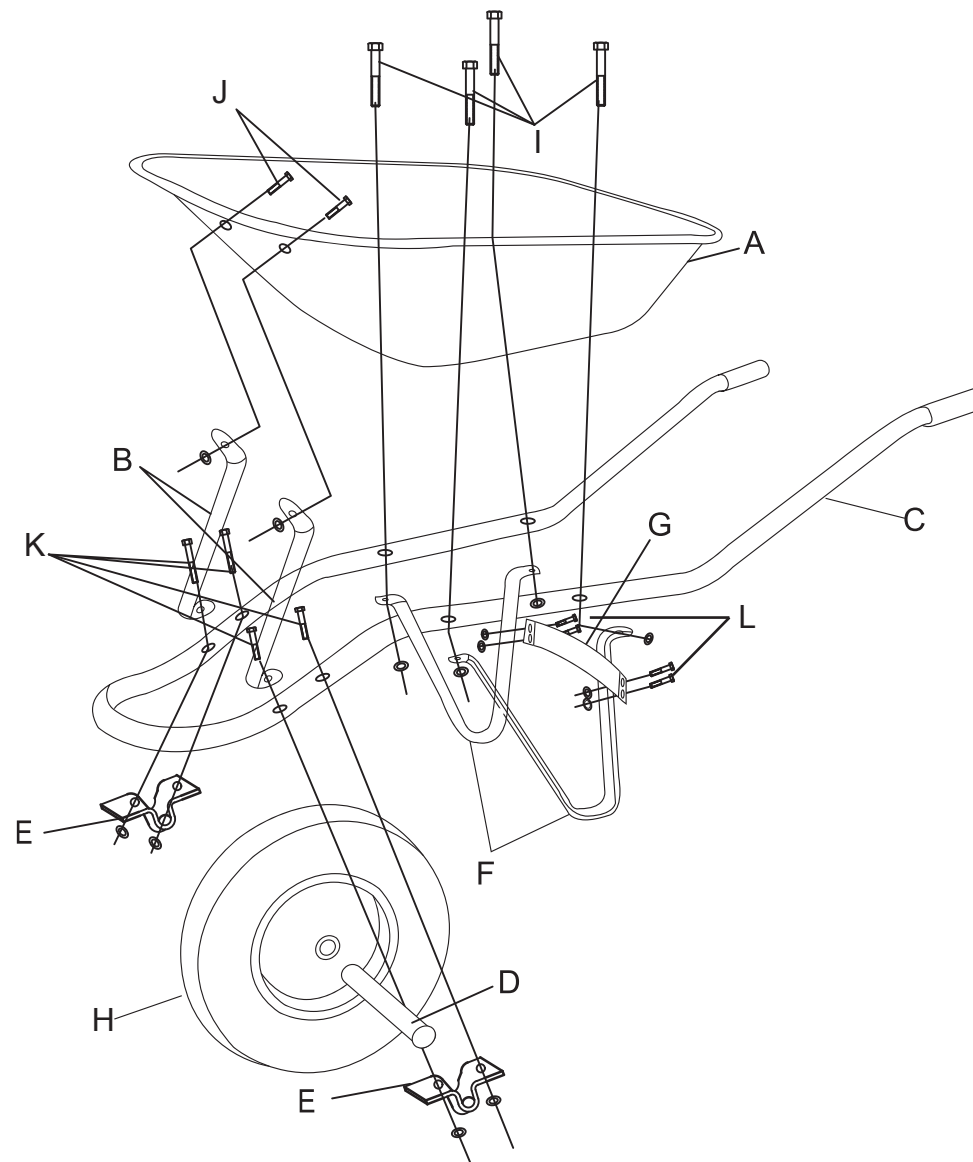



Distributed by:  
TRACTOR SUPPLY COMPANY  
5401 VIRGINIA WAY  
BRENTWOOD, TN 37027  
For customer support,  
Call: 1-888-376-9601  
[www.TractorSupply.com](http://www.TractorSupply.com)  
MADE IN CHINA



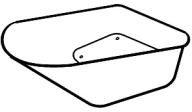

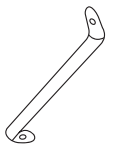

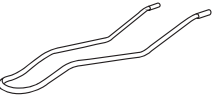
## TOOLS REQUIRED (NOT INCLUDED)

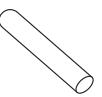
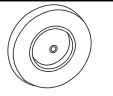

## PART LIST

| KEY | PART   | DESCRIPTION  | QTY. | KEY | PART  | DESCRIPTION  | QTY. |
|-----|--|--------------|------|-----|---|--------------|------|
| A   |   | Tray         | 1    | E   |  | Axle Bracket | 2    |
| B   |   | Tray Brace   | 2    | F   |  | Leg          | 2    |
| C   |   | Steel Handle | 1    | G   |  | Leg Brace    | 1    |
| D   |  | Axle         | 1    | H   |  | Wheel        | 1    |

## HARDWARE LIST

|   |   |              |   |   |   |              |   |
|---|---|--------------|---|---|---|--------------|---|
| I |  | M8X55mm Bolt | 4 | K |  | M8X45mm Bolt | 4 |
| J |  | M8X25mm Bolt | 2 | L |  | M8X20mm Bolt | 4 |

## ASSEMBLY INSTRUCTIONS

**Note:** Do not completely tighten screws until assembly has been completed.

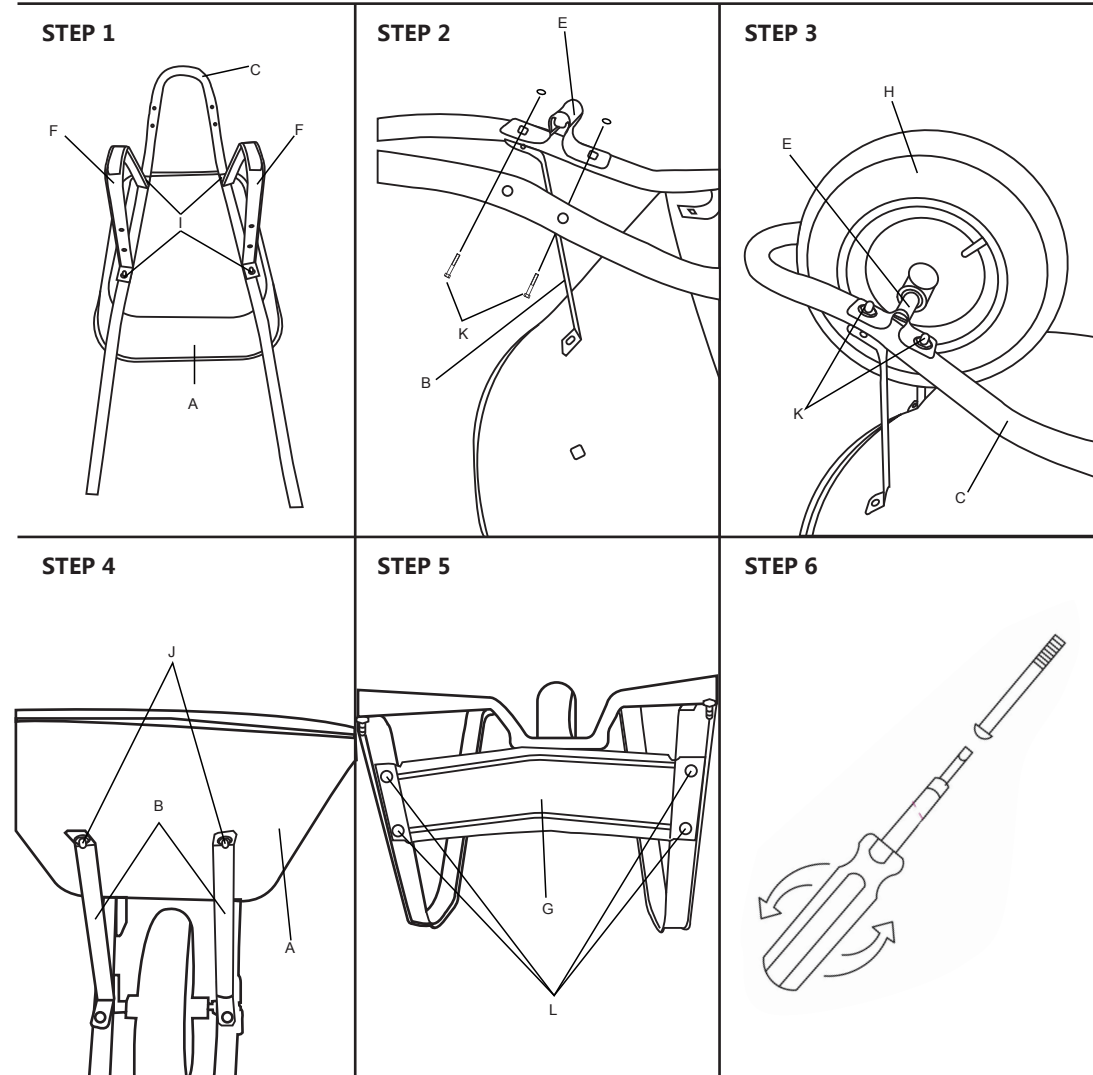

### CARE INSTRUCTIONS:

After use, clean with a wet, soft cloth or sponge. Rinse thoroughly. When not in use, store in a dry or sheltered location. If stored outdoors, place upright, upside down or sideways to ensure water does not collect in the tray to avoid rust formation.