

# TOMAHAWK

TGS30  
GRANULAR SPREADER

Operation Manual

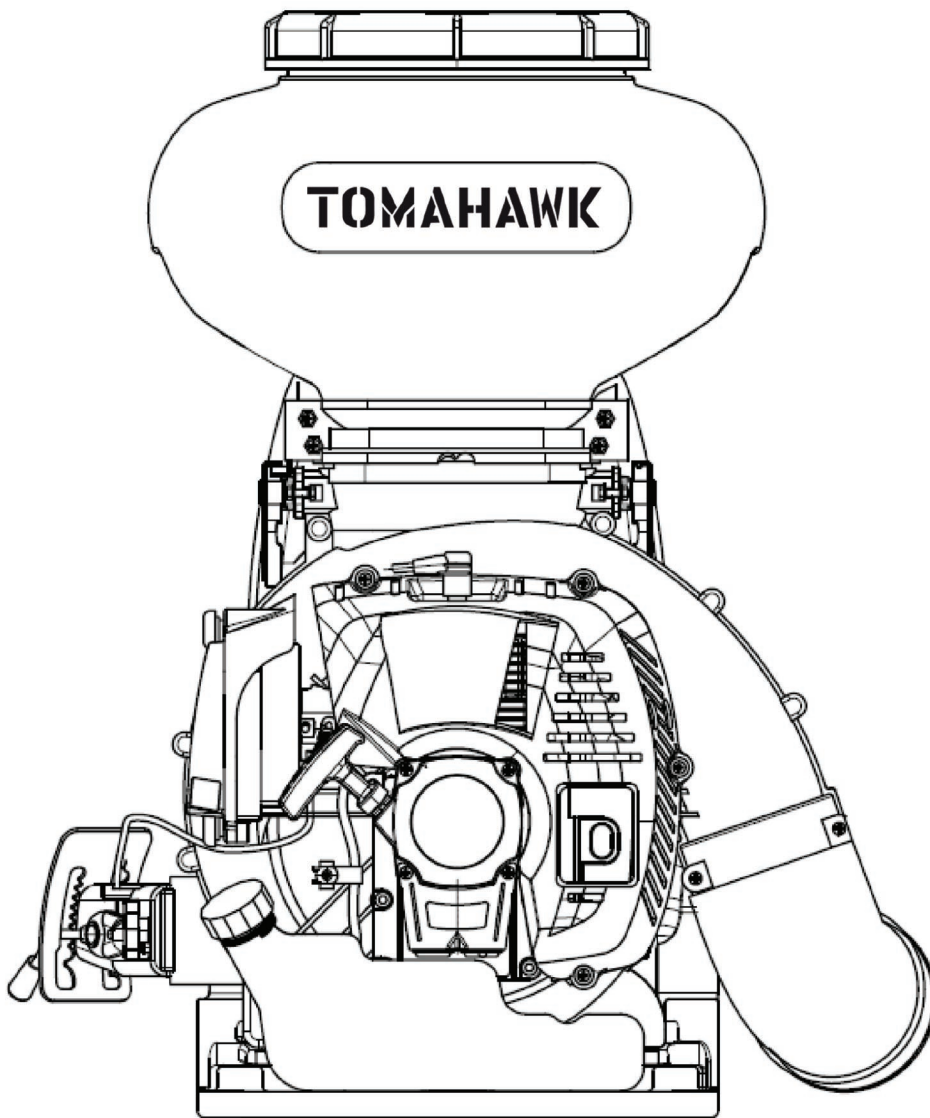

For safe operation follow all safety precautions in the TPS25 Backpack Sprayer Operation Manual. Improper use can cause serious injury.

# ***TABLE OF CONTENTS***

<b>TABLE OF CONTENTS</b>	<b>2</b>
<b>OPERATOR PRECAUTIONS</b>	<b>4</b>
<b>EQUIPMENT WARNINGS</b>	<b>4</b>
<b>CHEMICAL HANDLING</b>	<b>4</b>
<b>PART IDENTIFICATION</b>	<b>5</b>
<b>ACCESSORIES</b>	<b>5</b>
<b>ASSEMBLY GUIDE</b>	<b>6</b>
<b>FUELING</b>	<b>10</b>
<b>ADDING CHEMICALS, FERTILIZERS, AND PESTICIDE</b>	<b>10</b>
<b>START UP GUIDE</b>	<b>11</b>
<b>STARTING AND STOPPING YOUR ENGINE</b>	<b>12</b>
<b>SPREADING AND SPRAYING</b>	<b>13</b>
<b>TECHNICAL SPECIFICATIONS</b>	<b>13</b>
<b>FEATURES AND USES</b>	<b>14</b>
<b>MAINTENANCE AND TROUBLESHOOTING</b>	<b>14</b>
<b>STORAGE</b>	<b>16</b>
<b>EPA WARRANTY</b>	<b>17</b>
<b>PROPOSITION 65</b>	<b>20</b>
<b>TOMAHAWK WARRANTY</b>	<b>20</b>
<b>PRODUCT CATALOG</b>	<b>22</b>
<b>TOMAHAWK COUPON</b>	<b>23</b>



# Warnings

## Operator Precautions

1. This product emits carbon monoxide, an invisible and odorless toxin. Do not run this product indoors at any time.
2. Always turn engine off before adding fuel to the tank.
3. To avoid electrocution, do not touch the cap of the spark plug or wiring while the engine is on.
4. Do not touch the surface of the muffler and cylinder while the engine is running. It is extremely hot.
5. Do not spill pesticide or chemicals when filling or emptying tank.
6. Keep the area clear of people, children, and pets during operation of this machine.

## Equipment Warnings

1. The TGS30 is a 2 stroke engine that runs on a minimum of 50:1 fuel mix. It uses 91 octane gas and two cycle engine oil. Note: 50:1 pre-mix fuel is ideal for this product as it contains fuel stabilizer to ensure longevity of the equipment. Premix fuel can be found at your local hardware store or auto shop.
2. After starting the engine, keep the throttle at a low speed for several minutes before running at full throttle.
3. Gasoline is an extremely flammable fuel. When operating keep away from any flames. Do not smoke while operating.
4. Do not spray in the direction of others.
5. Understand the operation of the machine and understand how to shut off the equipment quickly in case of an emergency.

## Chemical Handling

1. Wear ear protection
2. Wear eye protection
3. Use a mask to protect mouth and face against dust and chemicals
4. Wear closed toed protective shoes
5. Wear pants and long sleeve shirt to protect to avoid chemical contact with arms and legs
6. Wear gloves to avoid contact with chemicals
7. After operating the machine, wash hands and clothing immediately.

# Part Identification

## NAME OF EACH PART

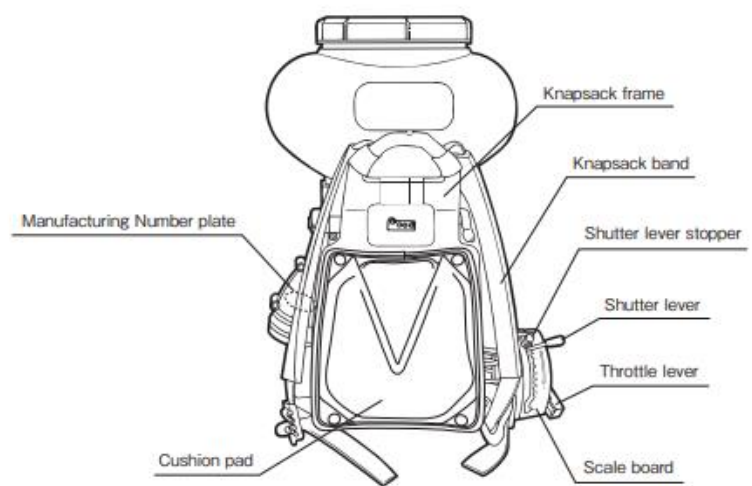
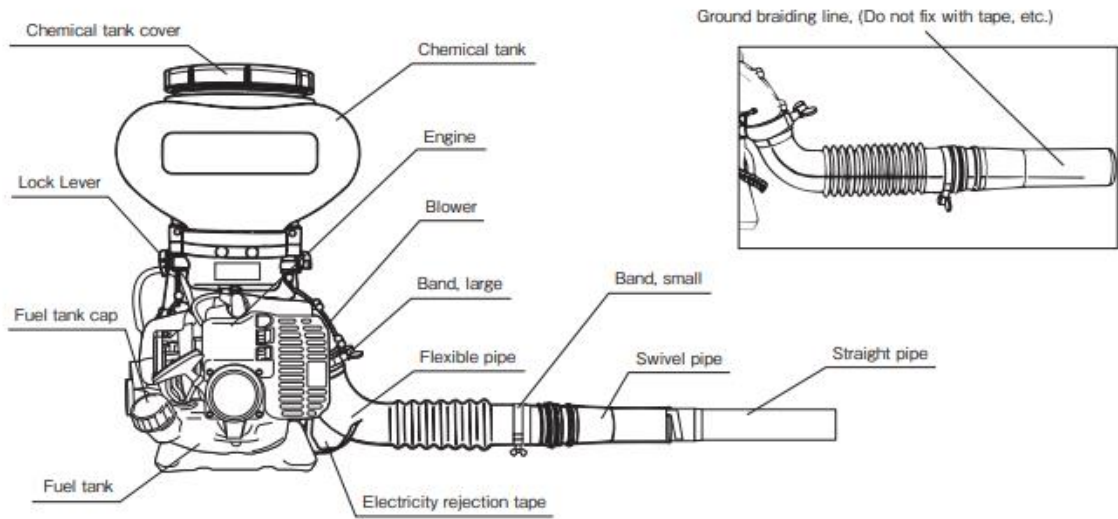

## ACCESSORIES

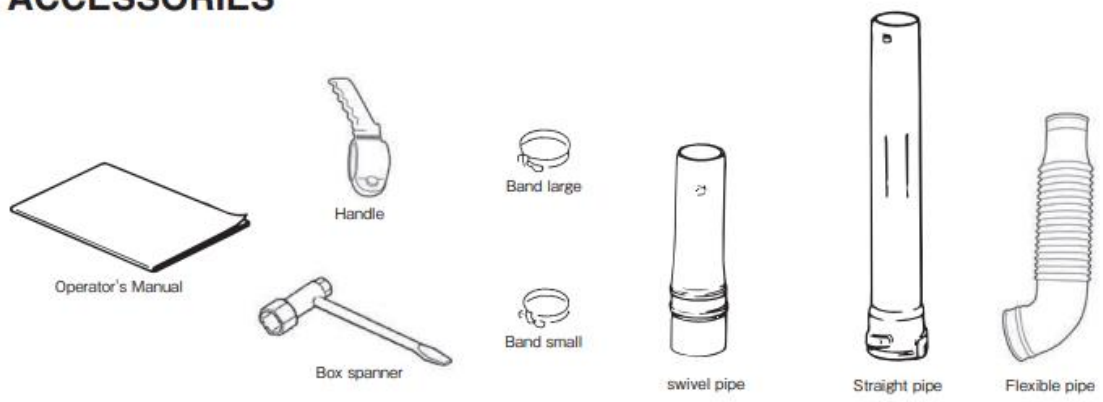

# TOMAHAWK

www.tomahawk-power.com

## TGS30: Assembly Guide Pt. 1



**1** Remove all parts from the TGS30 Granular Spreader Box.

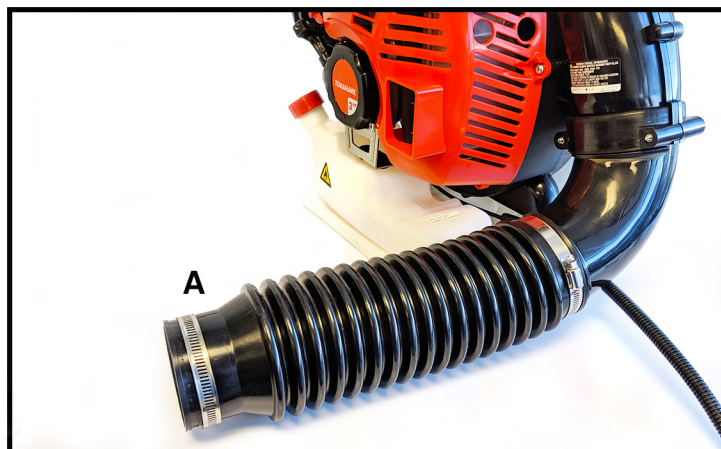

**2** Attach the ribbed tube (A) to the granular spreader's elbow.



**3** Fasten the clamp on the ribbed tube (A) to the elbow with a screwdriver.

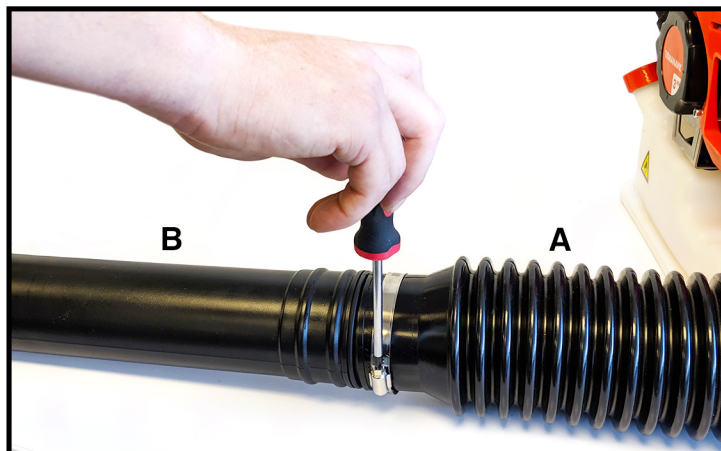

**4** Fasten the second clamp on the ribbed tube (A) to the straight tube (B).

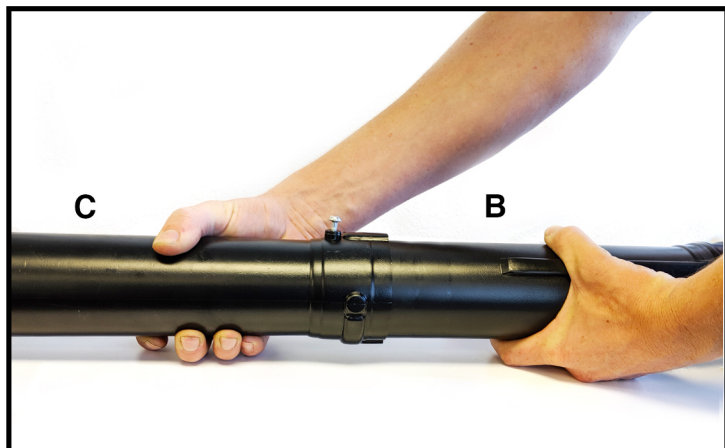

**5** Fasten the straight tube (B) to tube (C). Twist to lock.



**6** Tighten the screw with a screwdriver to fasten both tubes together.

# TOMAHAWK

www.tomahawk-power.com

TGS30: Assembly Guide Pt. 2

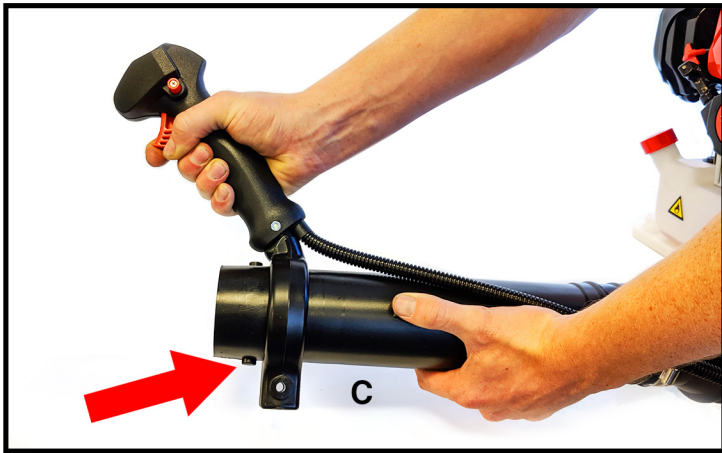

**1** Slide the accelerator handle over the tube (C). Adjust to your ideal position.



**2** Fasten the accelerator handle to the tube (C) with the wingnut washer.

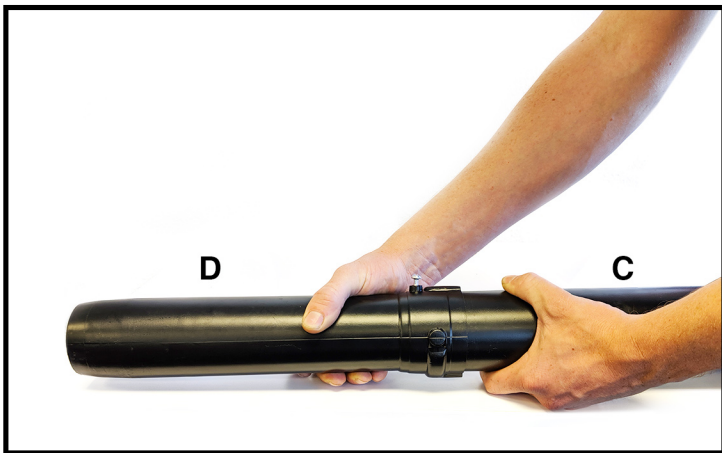

**3** Fasten tube (C) to tube (D) and tighten.

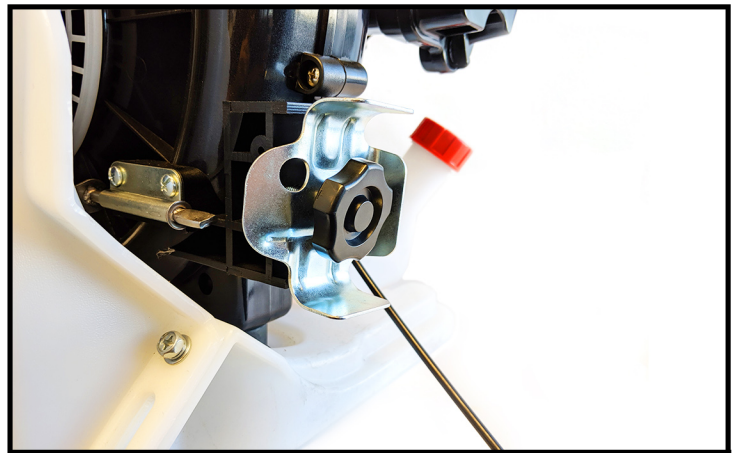

**4** Locate the throttle assembly.

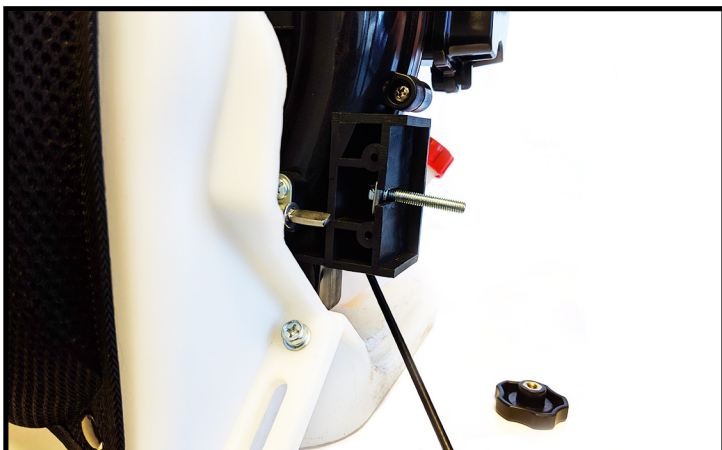

**5** Loosen the screw washer.

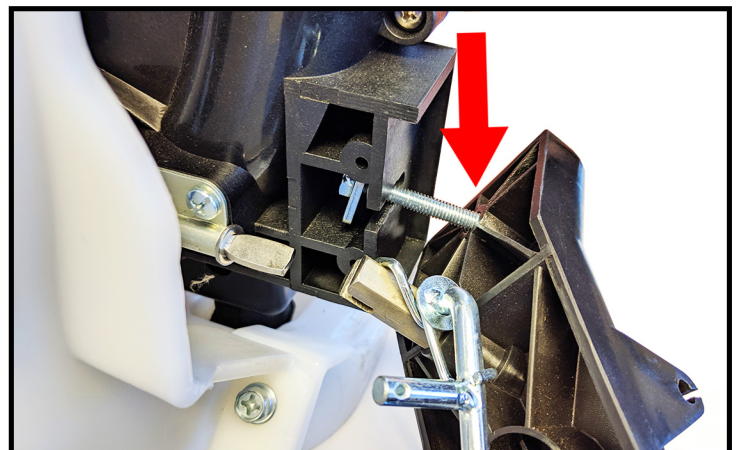

**6** Push the screw through the throttle assembly hole.

# TOMAHAWK

www.tomahawk-power.com

TGS30: Assembly Guide Pt. 3

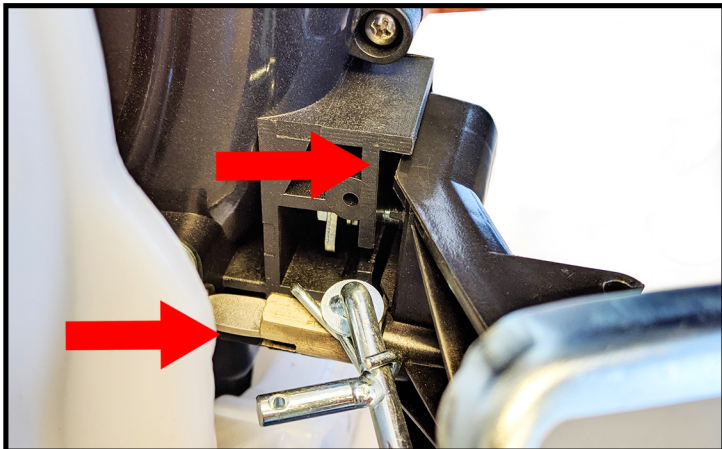

**1** Align the throttle assembly's slot into place and line up the housing.

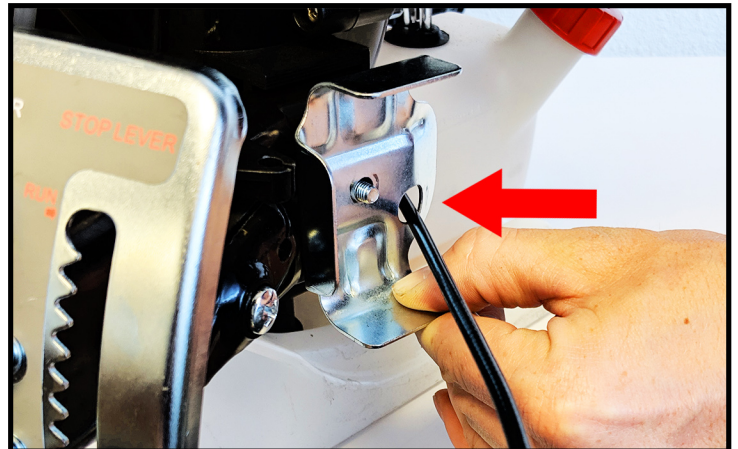

**2** Thread the accelerator cable through the metal hole and fasten the screw washer.

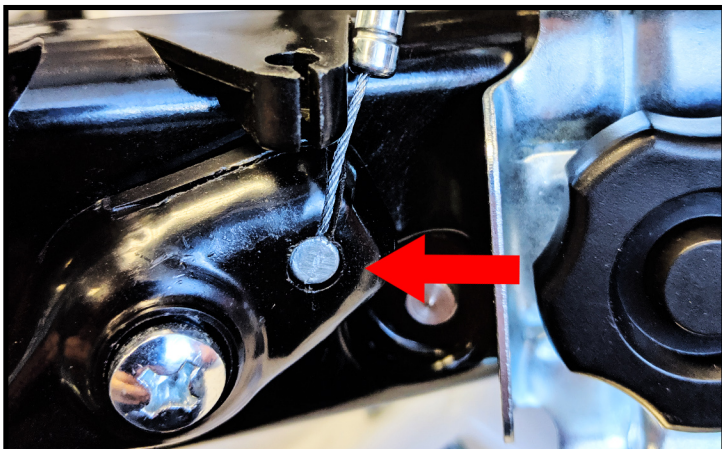

**3** Press the accelerator cable's end into slot above.

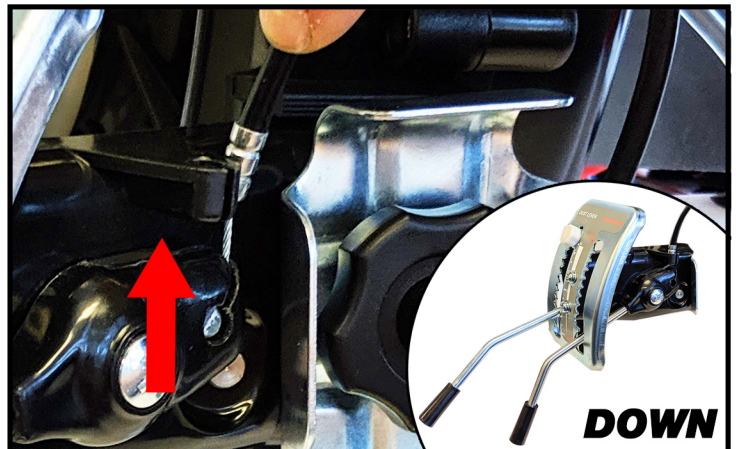

**4** Move the throttle down to lock the accelerator cable into the channel.

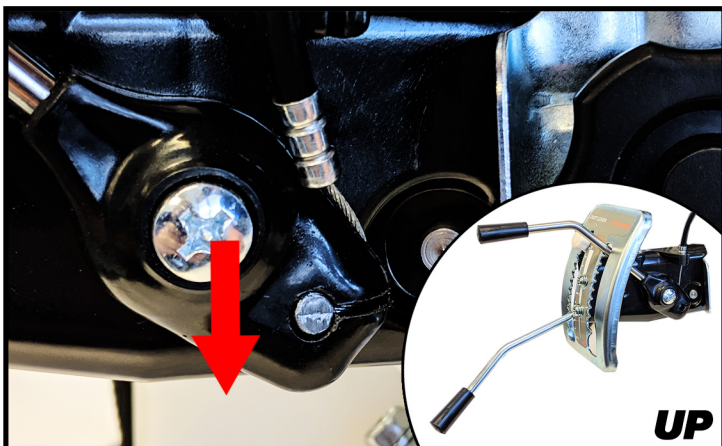

**5** Move the throttle up to tuck the accelerator cable into the upper channel.

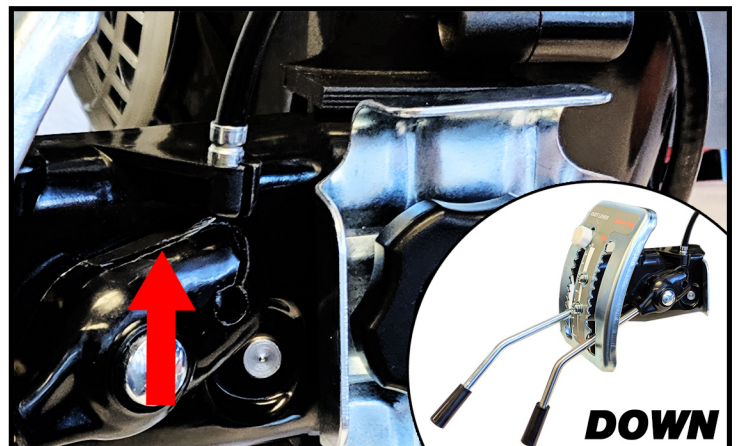

**6** Move the throttle down again to lock the accelerator cable into the last channel.





## Fueling

- This engine is certified to operate on unleaded gasoline and two-stroke engine oil at a mix ratio of 50:1.
- This engine requires a mixture of high-quality gasoline and two- stroke air cooled engine oil.
- Use mid-grade unleaded gasoline with a minimum octane rating of 91 and no more than 10% ethanol content.
- Keep the fuel tank far away from flames or sparks. Do not smoke near fuel.
- When adding pre-mixed fuel to the engine, use a funnel to avoid spillage.
- When the machine is running, do not add more to the fuel tank.
- Open the fuel cap carefully to allow and pressure build-up in the tank to release slowly and avoid fuel spillage.
- At the end of a season, drain all fuel from gas tank and use fuel stabilizer to insure a clear carburetor for your next season.

## Adding Chemicals, Fertilizers, and Pesticide

Align the shutter lever with “0”. 2. Remove the lump and feed in the chemical being careful not to spill it on the outside. When pouring the chemical into the tank, be careful not to spill the chemical on the outside. Only fill the tank with the amount to be sprayed. 3. Check the chemical tank cover packing and securely close the cover. If the cover is loose, it may affect the spraying. In addition, the chemicals might spill out and get on you. Use chemicals that do not contain foreign matter, such as dust, lumps, and that are dried well.

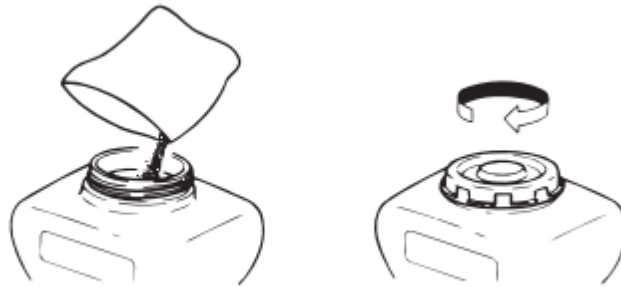

# TOMAHAWK

www.tomahawk-power.com

TGS30: Start Up Guide



**1** This backpack sprayer runs a pre-mix fuel ratio of 50:1.

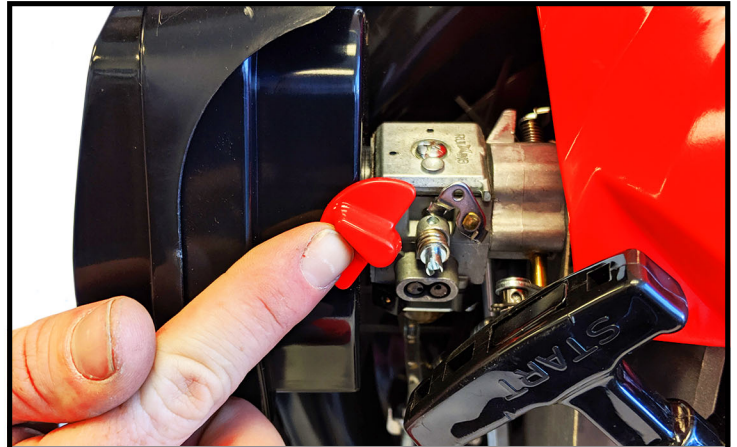

**2** Turn the choke to the UP position.

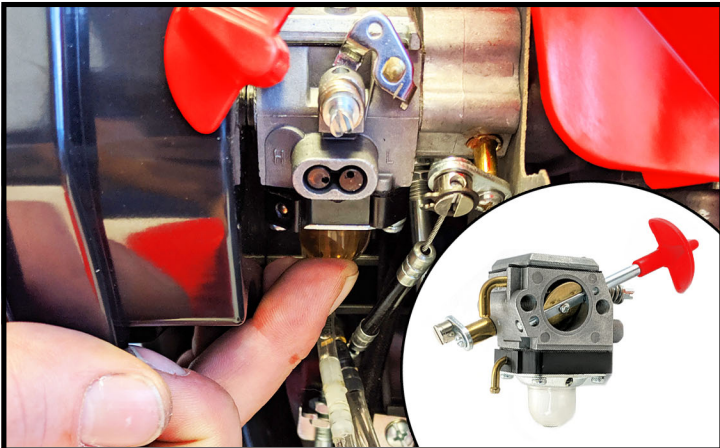

**3** Press the fuel injection bulb 3-5 times or until fuel is seen flowing through.



**4** Move the throttle handle to the UP position and the STOP LEVER halfway UP.

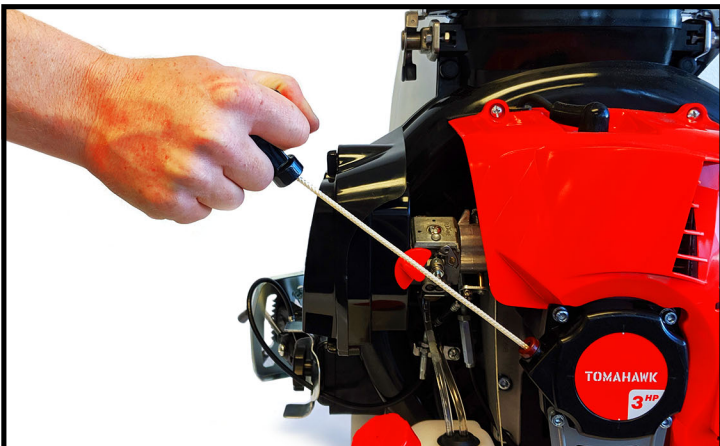

**5** Pull the engine's recoil starter cord until the engine starts.

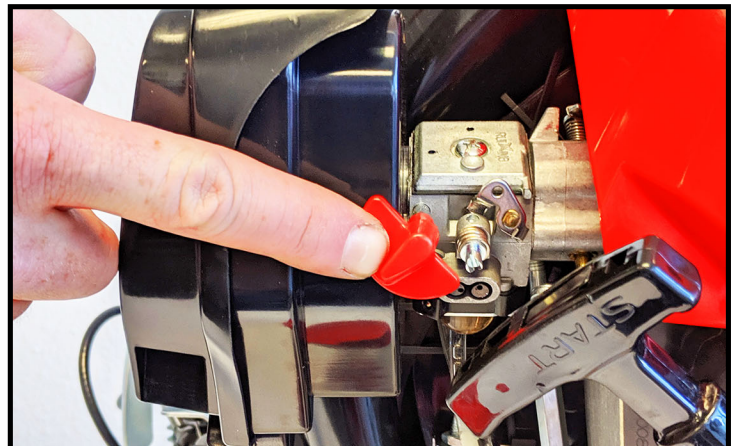

**6** Move the choke back to the DOWN position.

If your backpack sprayer fails to start check the Troubleshooting Guide in this manual or contact Tomahawk Power at [support@tomahawk-power.com](mailto:support@tomahawk-power.com) for Start Up assistance.

## STARTING AND STOPPING YOUR ENGINE

### Starting Your Engine:

*When starting the engine make sure the engine is fueled and the water tank prepped for spraying.*

1. Push the throttle lever to the on position marked (I).
2. Prime the engine 4-5 times, or until fuel is visibly passing through the fuel lines. See Figure 1.
3. Move the choke to the closed position.
4. Pull the recoil starter until the engine fires.
5. After the engine starts, slowly move the choke to the open position.
6. Let the engine idle for several minutes and then begin operation.

### Stopping Your Engine:

1. Move the water valve to the closed position to stop the flow of liquid pesticide.
2. Move the throttle lever to the down position (O) to stop the engine.
3. Move the choke to the closed position.

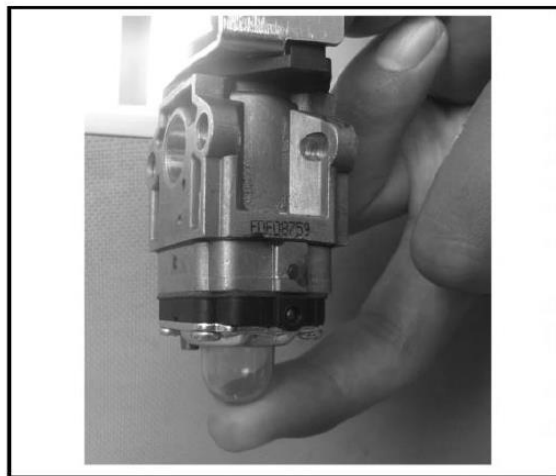

**FIGURE 1**

## Spreading and Spraying

Using the accelerator will control the speed of the engine. This will adjust the distance and spread of the granular and spraying.

Using the Shutter lever adjusts the amount granular chemicals that leave the tank. In the down position no granular chemicals will spread in the up position the maximum amount of granular will enter through the Granular sprayer.

Note: at full throttle the spreader with the lever all the way up the this product will spread up to 38lbs of fertilizer/ small granular per minute.

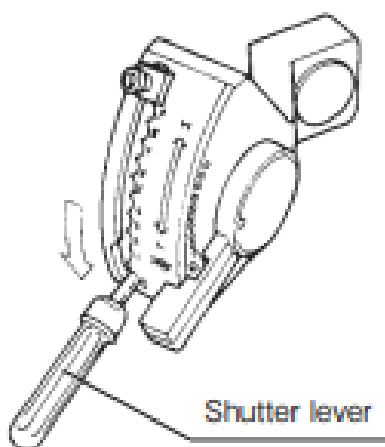

## Technical Specifications

<b>Brand</b>	Tomahawk Power
<b>Model</b>	TGS30
<b>Engine</b>	79 cc
<b>Fuel Type</b>	2 stroke engine 50:1 Premix Fuel
<b>Fuel Tank Capacity</b>	1.05 qts
<b>Ignition System</b>	Electronic
<b>Carburetor</b>	Diaphragm
<b>Tank Size</b>	8 Gallon Granular Tank
<b>Spread distance</b>	40+ ft (Conical Spread)
<b>Standard Attachments</b>	Accordion Elbow, Swivel Pipe, Straight Pipe
<b>Dimensions</b>	15"x17"x 28"
<b>Dry Weight</b>	20 lbs
<b>Warranty</b>	2 Year Commercial Warranty

## Features and Uses

Features	Works Great For
<ul style="list-style-type: none"> <li>• Spreads upwards of 40+ ft</li> <li>• Very powerful engine to get job done quickly</li> <li>• Oversized tank allows less downtime</li> <li>• Professional Engine backed by a 2 Year Warranty</li> <li>• Spray an acre in 20 minutes</li> <li>• Can attach chemical tank for pesticide spraying</li> <li>• Can operate as a leaf blower</li> </ul>	<ul style="list-style-type: none"> <li>• Commercial &amp; Residential Landscapers</li> <li>• Golf Course Maintenance</li> <li>• Parks and Recreation</li> <li>• Greenhouses</li> <li>• Ornamental Plants</li> <li>• Orchards</li> <li>• Sports Fields</li> <li>• Vegetable and Fruit Field Fertilization</li> <li>• De-Icing and Salt Spreading</li> <li>• Turf Care Professionals</li> <li>• Pond and Algae Control</li> <li>• Fish food and farming applications with aquaculture</li> </ul>

## Maintenance and Troubleshooting

### Maintenance

Before fixing your equipment, make sure the engine is turned off and completely cooled down.

### Spark Plug:

PROBLEM		CAUSE	SOLUTION
No Spark	Spark Plug	1. Spark plug is wet	Dry Spark Plug
		2. Spark plug is dirty	Clean
		3. The insulation is damaged	Replace
		4. Spark gap is off	Adjust
	Ignition coil	1. Wrap of wire damaged	Fix or Replace
		2. Insulation of coil bad	Replace
3. The wire of coil broken		Replace	
Normal Spark	Good Compression ratio	1. Too much fuel in the cylinder	Drain
		2. Water or dirt in the fuel	Replace
	Poor Compression Ratio	1. Cylinder and piston ring worn or torn	Replace
		2. The plug is loose	Tighten
	Carburetor Not Fueling	1. No fuel in the tank	Add Fuel
		2. Filter gauge is clogged	Clean
		3. Fuel tank has a hole	Clean

### Engine Lacks Power:

PROBLEM	CAUSE	SOLUTION
Good Compression Ratio	1. Filter is clogged	Clean
	2. Air passes through the connection of carburetor	Tighten
	3. Engine overheats	Stop Engine. Let Cool.
	4. Water in the fuel	Replace Fuel
	5. Dirt clogs the muffler	Clean
Engine Overheats	1. Gas is thin in fuel mix	Replace Fuel
	2. Cylinder is dirty	Clean
	3. Oil is bad	Replace Fuel with New 50:1 Pre Mix Fuel
	4. No connection with hose	Adjust hose connection
Engine is noisy or knocking	1. Fuel bad Replace fuel	Replace Fuel
	2. Dirt in cylinder	Clean
	3. Parts are worn	Fix or Replace

### Engine stops while running:

PROBLEM	CAUSE	SOLUTION
Engine stops suddenly	1. Wire of plug is loose	Replace
	2. Piston is broken	Fix or Replace
	3. Plug is dirty	Clean
	4. Fuel is empty	Add Fuel
The engine stops slowly	1. Carburetor is dirty	Clean
	2. Hoses to tank are clogged	Clean
	3. Water in the fuel	Replace Fuel

### Engine is difficult to stop:

PROBLEM	CAUSE	SOLUTION
The engine still runs with the throttle at its lowest position	1. The throttle cord has short circuited or carburetor piston is blocked.	Fix or Replace Cord

## Difficulties dusting:

PROBLEM	CAUSE	SOLUTION
No dust discharge or discharge is intermittent	1. The dust gate cannot be opened	Adjust
	2. The tank lid not is tight	Tighten
	3. The dust or granule is dirty	Clean
	4. The dust/granule has lumps	Break lumps or replace
	5. The granules are too big	Use smaller granule
The dust gate does not work properly	1. Carburetor is dirty	Clean
	2. Hoses to tank are clogged	Clean
Dust leakage	1. The clamp plate of the chemical tank bottom is loose	Tighten
	2. The sealing gasket of the dusting lid is damaged	Replace
	3. The O ring of the elbow is damaged	Replace
The discharge rate is out of control	1. The dust control lever is not work properly	Adjust the cord or fix the carburetor.

## Difficulties fogging (when using Liquid Tank Conversion Kit):

PROBLEM	CAUSE	SOLUTION
No mist or mist is irregular	1. Nozzle switch or control valve is clogged	Clean
	2. Liquid lead pipe is clogged	Clean
	3. No pressure or low pressure	Tighten the tank lid and screw down the two wing nuts.
Spray mixture leak	1. The lid is placed incorrectly	Tighten correctly
	2. Thread joints are loose	Tighten correctly

## Storage

For long-term storage of the duster, first perform all regular maintenance procedures and needed repairs. Empty the fuel tank. Disconnect the fuel supply line from the carburetor and depress the primer bulb until fuel stops discharging from the fuel-return line. Start the engine and allow it to run until it stops. Pull the starter cord a few times to remove any excess fuel from the engine. Remove the spark plug and insert a small amount of oil into the cylinder. Slowly pull the starter cord and bring the piston to a position closest to the spark plug hole. Re-install the spark plug. Apply a thin coating of oil to all the metal surfaces and store the duster in a dry place.



## **EPA Warranty**

### **CALIFORNIA AND FEDERAL EMISSION CONTROL WARRANTY STATEMENT YOUR WARRANTY RIGHTS AND OBLIGATIONS**

The California Air Resources Board, the United States Environmental Protection Agency and Tomahawk Power, LLC are pleased to explain the emissions control system warranty on your 2018-2019 small engine/equipment (SORE). In the United States and California, new small engine/equipment must be designed, built and equipped to meet the State's stringent anti-smog standards. Tomahawk Power, LLC must warrant the emissions control system on your small engine/equipment for the periods of time listed below provided there has been no abuse, neglect or improper maintenance of your small engine/equipment. Your emission control system may include parts such as the carburetor, fuel-injection system, the ignition system, catalytic convertor, fuel tanks, fuel lines, fuel caps, valves, canisters, filters, vapor hoses, belts, clamps, connectors, and other associated emission related components. For engines less than or equal to 80 cc, only the fuel tank is subject to the evaporative emission control warranty requirements of this section.  
(California only)

Where a warrantable condition exists, Tomahawk Power, LLC will repair your small off-road engine/equipment at no cost to you including diagnosis, parts and labor.

#### **MANUFACTURER'S WARRANTY COVERAGE:**

The emissions control system is warranted for two years. If any emissions-related part on your small engine/equipment is defective, the part will be repaired or replaced by Tomahawk Power, LLC.

#### **OWNER'S WARRANTY RESPONSIBILITIES:**

As the small engine/equipment owner, you are responsible for the performance of the required maintenance listed in your owner's manual. Tomahawk Power, LLC recommends that you retain all receipts covering maintenance on your small engine/ equipment, but Tomahawk Power, LLC cannot deny warranty solely for the lack of receipts or for your failure to ensure the performance of all scheduled maintenance.

As the small engine/equipment owner, you should however be aware that Tomahawk Power, LLC may deny your warranty coverage if your small engine/equipment or a part has failed due to abuse, neglect, improper maintenance or unapproved modifications. You are responsible for presenting your small engine/equipment to distribution center or service center authorized by Tomahawk Power, LLC as soon as the problem exists. The warranty repairs should be completed in a reasonable amount of time, not to exceed 30 days.

If you have any questions regarding your warranty rights and responsibilities, you should contact Tomahawk Power, LLC customer service representative at 1-866-577-4476 or Email: [support@tomahawk-power.com](mailto:support@tomahawk-power.com).

#### **DEFECTS WARRANTY REQUIREMENTS**

(a)The warranty period begins on the date the small engine/equipment is delivered to an ultimate purchaser.

(b)General Emissions Warranty Coverage. Tomahawk Power, LLC warrants to the ultimate purchaser and each subsequent owner that the engine/equipment is:

- (1) Designed, built, and equipped so as to conform with all applicable regulations adopted by the Air Resources Board; and
- (2) Free from defects in materials and workmanship that causes the failure of a warranted part for a period of two years.
- (c) Subject to certain conditions and exclusions as stated below, the warranty on emissions related parts is as follows:
  - (1) Any warranted part that is not scheduled for replacement as required maintenance in your **Owner's Manual** is warranted for the warranty period stated above. If the part fails during the period of warranty coverage, the part will be repaired or replaced by Tomahawk Power, LLC according to Subsection (4) below. Any such part repaired or replaced under warranty will be warranted for the remainder of the period.
  - (2) Any warranted part that is scheduled only for regular inspection in your **Owner's Manual** is warranted for the warranty period stated above. Any such part repaired or replaced under warranty will be warranted for the remaining warranty period.
  - (3) Any warranted part that is scheduled for replacement as required maintenance in your **Owner's Manual** is warranted for the period of time before the first scheduled replacement date for that part. If the part fails before the first scheduled replacement, the part will be repaired or replaced by Tomahawk Power, LLC according to Subsection (4) below. Any such part repaired or replaced under warranty will be warranted for the remainder of the period prior to the first scheduled replacement point for the part.
  - (4) Repair or replacement of any warranted part under the warranty provisions herein must be performed at a warranty station at no charge to the owner.
  - (5) Notwithstanding the provisions herein, warranty services or repair will be provided at all of our distribution centers that are franchised to service the subject small engine/equipment.
  - (6) The small engine/equipment owner must not be charged for diagnostic labor that leads to the determination that a warranted part is in fact defective, provided that such diagnostic work is performed at a warranty station.
  - (7) Tomahawk Power, LLC is liable for damages to other small engine/equipment components proximately caused by a failure under warranty of any warranted part.
  - (8) Throughout the small engine/equipment warranty period stated above, Tomahawk Power, LLC will maintain a supply of warranted parts sufficient to meet the expected demand for such parts.
  - (9) Any replacement part may be used in the performance of any warranty maintenance or repairs and must be provided without charge to the owner. Such use will not reduce the warranty obligations of Tomahawk Power, LLC
  - (10) Add-on or modified parts that are not exempted by the Air Resources Board may not be used. The use of any non-exempted add-on or modified parts by the ultimate purchaser will be grounds for disallowing a warranty claims. Tomahawk Power, LLC will not be liable to warrant failures of warranted parts caused by the use of a non-exempted add-on or modified part.
  - (11) The manufacturer issuing the warranty shall provide any documents that describe that manufacturer's warranty procedures or policies within five working days of request by the Air Resources Board.

#### EMISSION WARRANTY PARTS LIST

The repair or replacement of any warranted part otherwise eligible for warranty coverage may be excluded from such warranty coverage if Tomahawk Power, LLC demonstrates that the small engine/equipment has been abused, neglected, or improperly maintained and that such abuse, neglect, or improper maintenance was the direct cause of the need for repair or replacement of the part. That notwithstanding, any adjustment of a component that has a factory installed, and properly operating, adjustment limiting device is still eligible for warranty coverage. The following emissions warranty parts for each engine family list is covered.

For engine families greater than 80cc:

- (1) Fuel Metering System:
  - (a) Gasoline carburetor assembly and its internal components
  - (b) Carburetor gaskets
  - (c) Fuel tank
  - (d) Fuel Line
  - (e) Fuel Line Fittings
  - (f) Clamps
  - (g) Pressure regulator (if equipped)
  - (h) Mixer assembly and its internal components (if equipped)
- (2) Air Induction System including:
  - (a) Intake pipe/manifold
  - (b) Air cleaner
- (3) Ignition System including:
  - (a) Spark plug
  - (b) Ignition coil
- (4) Catalytic Muffler Assembly including:
  - (a) Muffler gasket
  - (b) Exhaust manifold
  - (c) Catalytic converter
- (5) Crankcase Breather Assembly including:
  - (a) Breather connection tube.
- (6) Fuel tank evaporative emissions control system including:
  - (a) Purge Valves
  - (b) Carbon Canister
  - (c) Canister Mounting Brackets
  - (d) Fuel Cap
  - (e) Fuel Tank
- (7) Miscellaneous items Used in Above Systems including:
  - (a) Switches
  - (b) Hoses, belts, connectors, and assemblies.
- (8) Air injection system
  - (a) Pulse valve

For engine families less than or equal to 80cc:

- (1) Fuel Metering System:
  - (a) Gasoline carburetor assembly and its internal components
  - (b) Fuel filter (if so equipped)
  - (c) Carburetor gaskets
  - (d) Fuel pump (if so equipped)
- (2) Air Induction System including:
  - (a) Intake pipe/manifold
  - (b) Air cleaner
- (3) Ignition System including:
  - (a) Spark plug
  - (b) Ignition module/coil
- (4) Catalytic Muffler Assembly (if so equipped) including:
  - (a) Muffler gasket
  - (b) Exhaust manifold
- (5) Crankcase Breather Assembly including:
  - (a) Breather connection tube.
- (6) Miscellaneous items Used in Above Systems including:
  - (a) Switches

(b) Hoses, belts, connectors, and assemblies.

(7) Fuel tank evaporative emissions control system including:

(a) Fuel Tank

The warranty is provided in accordance with the "California AND FEDERAL Emission Control Warranty Statement".

## Proposition 65

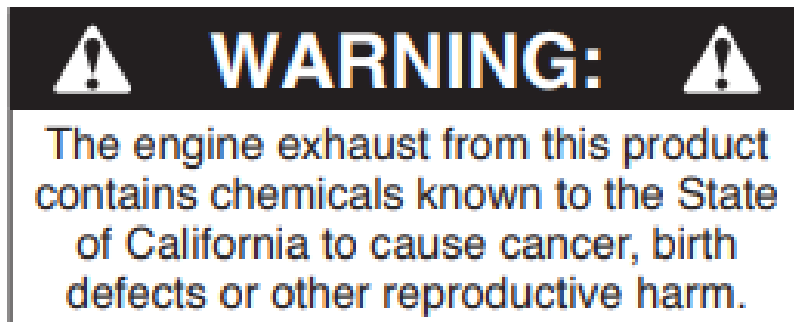

## Tomahawk Limited Warranty Statement

The Tomahawk TGS30 Commercial Granular Sprayer is warranted to the original purchaser to be free from defects in material and workmanship from the date of purchase for the time periods listed as follows:

### **2 years for Commercial Use**

Any part of the TGS30 Granular sprayer found to be defective within the applicable warranty period shall, at Tomahawk Power's option, be repaired or replaced without charge. Warranty consideration is obtained by delivering any Tomahawk Power product to an Authorized Tomahawk Power Dealer / Service Center within the applicable warranty period. Or calling Tomahawk Power.

This warranty does not cover the following:

1. Maintenance items (excluding defects in materials and workmanship) including hoses, spark plugs, starter rope, air and fuel filters, clutch shoes, vibration isolators, throttle cables and all cutting attachments, etc.
2. Extra expenses including shipping and handling, travel, payment for lost time or pay and for any inconvenience and storage.
3. Alterations or modifications including aftermarket parts not authorized by Tomahawk Power, LLC.

4. Wear, accident, abuse, neglect, misuse, negligence, improper fuels, lubricants, fuel mixtures (when applicable), or failure to operate or maintain the product in accordance with instructions approved by Tomahawk. Repair or replacement as provided under this warranty is the exclusive remedy of the consumer. Tomahawk shall not be liable for any incidental or consequential damages for breach of any express or implied warranty on these products except to the extent prohibited by applicable law. Any implied warranty of merchantability or fitness for a particular purpose on these products is limited in duration to the warranty period as defined in the limited warranty statement. Tomahawk reserves the rights to change or improve the design of the product without notice and does not assume obligation to update previously manufactured products. This warranty provides you with specific legal rights, which may vary from state to state. It is the Owner's and Dealer's responsibility to make sure the Warranty Registration is properly filled out online at [www.tomahawk-power.com](http://www.tomahawk-power.com)

# TOMAHAWK

## 2020 PRODUCT CATALOG

### COMPACTION



HONDA  
ENGINES

**3,550 lbs/ft Vibratory Rammer**  
Part#: TR68H

3.6 HP Honda GXR120 Engine  
Easily achieve a 100% compaction rating  
3-in-One Fuel System with carburetor protection  
13" x 11" plate for narrow trenches and corners  
3 Year Engine Warranty & 1 Year Product Warranty



HONDA  
ENGINES

**3,400 lbs/ft Plate Compactor**  
Part#: TPC90H

5.5 HP Honda GX160 Engine  
Easily achieve a 100% compaction rating  
22" x 20" cold, rolled steel beveled base plate  
Includes 3.5 gallon water tank for asphalt compaction  
3 Year Engine Warranty & 1 Year Product Warranty



KOHLER  
ENGINES

**3,000 lbs/ft Plate Compactor**  
Part#: TPC80

6 HP Kohler Command PRO Engine  
Easily achieve a 100% compaction rating  
16.5" x 21.5" plate for narrow trenches and corners  
Optional Honda Engine model: TPC80H  
3 Year Engine Warranty & 1 Year Product Warranty

### FINISHING



**6.5 Gal Backpack Concrete Sprayer**  
Part#: TCS6.5

Maintain constant, adjustable pressure up to 435 PSI  
Achieve superior concrete finishes with even spraying  
Spray 15,000 sq ft in less than 10 minutes  
Compatible with major manufacturer wands  
1 Year Product Warranty



HONDA  
ENGINES

**1.6 HP Vibratory Concrete Screed**  
Part#: TVSA-H

1.6 HP Honda GX35 Engine  
Aluminum Magnesium blades available from 8ft - 14ft  
Finish concrete 4X faster than other screed methods  
360° adjustable handle placement  
3 Year Engine Warranty & 1 Year Product Warranty

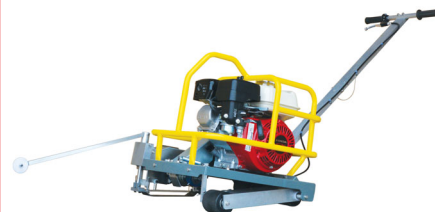

HONDA  
ENGINES

**6" Early Entry Green Concrete Saw**  
Part#: TFS6H

5.5 HP Honda GX160 Engine  
Maximum cutting depth of 1 3/16 inches  
OSHA compliant vacuum port for dust collection  
Includes 6" early entry concrete blade  
3 Year Engine Warranty & 1 Year Product Warranty

### GENERATORS



INVERTER SERIES

**2000 Watt Inverter Generator**  
Part#: TG2000i

2000 Max Watts, 1600 Rated Watts  
Run Time of 8 hours on 1 gallon of gas  
OSHA and GFCI Compliant  
Parallel technology capable for double the power  
2 Year Product Warranty



INVERTER SERIES

**3500 Watt Inverter Generator**  
Part#: TG3500i

3500 Max Watts, 3000 Rated Watts  
Run Time of 20 hours on 3.5 gallon of gas  
OSHA and GFCI Compliant  
Parallel technology capable for double the power  
2 Year Product Warranty



**4000 & 7000 Watt Generators**  
Part#: TG4000 & TG7000

4000 / 7000 Max Watts, 2500 / 5500 Rated Watts  
Run Time of 8 hours at 50% Load  
OSHA and GFCI Compliant  
Wheel kits available for more jobsite portability  
2 Year Product Warranty

HAVE QUESTIONS?

Contact us. *We're here to help!*

Email us at [sales@tomahawk-power.com](mailto:sales@tomahawk-power.com)



USE CODE  
**SAVE10**  
AT CHECKOUT FOR  
**10% OFF**  
YOUR NEXT ORDER\*

**WELDING / POWER**

INVERTER SERIES



**120 Amp Portable Welder Generator**  
Part#: TWG120A

Steady 120 Amp DC welding output  
60% Duty Cycle for extended use  
Suitable for welding rods from 6010 to 6013  
Includes wheel kit for job site portability  
2 Year Product Warranty

INVERTER SERIES



**210 Amp Portable Welder Generator**  
Part#: TWG210A

Steady 50 - 210 Amp DC welding output  
60% Duty Cycle for extended use  
Suitable for welding rods from 6010 to 7024  
Electric Key Start with battery included  
2 Year Product Warranty



**7500 & 9000 Watt Generators**  
Part#: TG7500 & TG9000

7500 / 9000 Max Watts, 6500 / 8500 Rated Watts  
Run Time of 10 hours at 50% Load  
7 gallon fuel tank for extended use  
Electric Key Start with battery included on TG9000  
2 Year Product Warranty

**PEST CONTROL**



**3.7 Gallon 3HP Backpack Fogger**  
Part#: TMD14

Turbo Boosted Pump with 40ft + Horizontal Reach  
Sprays 1 acre in 30 minutes  
10X Faster than Manual Pump Sprayers  
Converts to Leaf Blower with 200 MPH Air Velocity  
1 Year Engine Warranty & 1 Year Product Warranty



**5 Gallon 1.8HP Backpack Sprayer**  
Part#: TPS25

Reach Up to 30ft Horizontal Reach  
Sprays 1 acre in 15 minutes  
10X Faster than Manual Pump Sprayers  
Commercial Grade Pump  
1 Year Engine Warranty & 1 Year Product Warranty



**4 Gallon 3HP Backpack Spreader**  
Part#: TGS30

Reach Up to 30ft Horizontal Reach  
Covers 1 acre in less than 30 minutes  
20X Faster than Manual Broadcast Spreaders  
Converts to Fogger with Liquid Tank Accessory  
1 Year Engine Warranty & 1 Year Product Warranty

**AND MORE**



**8" Gas Powered Concrete Scarifier**  
Part#: TSCAR8H

5.5 HP Honda GX160 Engine  
Remove traffic lines at 800 - 1,000 linear ft/hr  
Tungsten Carbide Blade Kit Available  
OSHA approved dust port for silica vacuum removal  
3 Year Engine Warranty & 1 Year Product Warranty

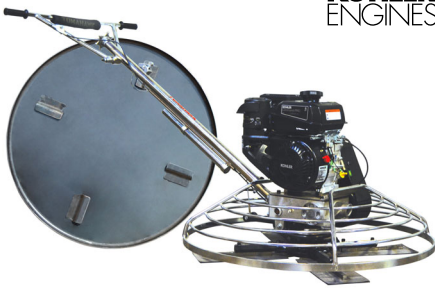

**36" & 46" Concrete Power Trowel**  
Part#: TPT36K & TPT46K

6 HP Kohler CH260 & 9.5 HP Kohler CH395 Engines  
Adjust trowel blade pitch from 0-28°  
60-115 RPM rotor speed for superior concrete finishes  
Includes float pan and trowel blades  
3 Year Engine Warranty & 1 Year Product Warranty



**2" and 3" Trash Water Pumps**  
Part#: TW2 & TW3

Moves liquids at a rate up to 9,240 gallons/hour  
Handle solids up to 0.6"  
Cast iron impeller for smooth performance  
6.5 HP engine protected by rugged all purpose frame  
1 Year Product Warranty

(866) 577-4476

\* Visit [www.tomahawk-power.com](http://www.tomahawk-power.com) for terms and conditions. Coupon must be redeemed at checkout at [www.tomahawk-power.com](http://www.tomahawk-power.com). Coupon may be subject to change and/or expire at any time, without notice.

[www.tomahawk-power.com](http://www.tomahawk-power.com)



## Power Your World

Tomahawk understands to keep a job-site running smoothly the proper equipment and spare parts are needed at the drop of a hat. With same day shipping and faster delivery times, count on Tomahawk to keep you powered throughout the day! With long lasting parts and engines, Tomahawk equipment will be the star of your fleet for years to come. Visit [www.tomahawk-power.com](http://www.tomahawk-power.com) to get started today!

# TOMAHAWK

Tomahawk Power, LLC  
San Diego, CA

**Sales Support**  
(866) 577-4476  
[sales@tomahawk-power.com](mailto:sales@tomahawk-power.com)

[www.tomahawk-power.com](http://www.tomahawk-power.com)

