

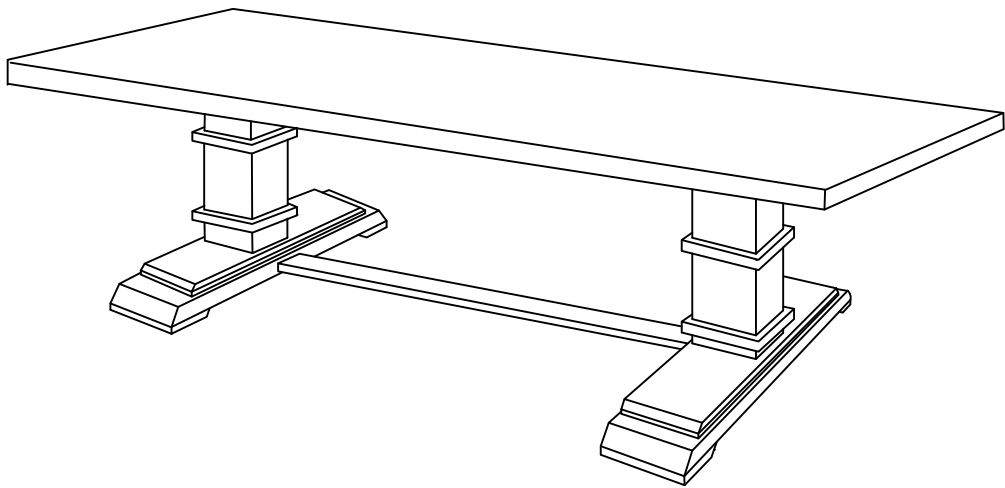







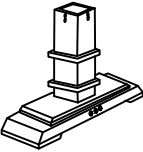

Dining Bench
CF5023



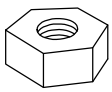
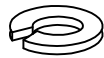

PART LIST

A	B	C	D	E
				
Seat Panel 1 PC	Leg 2 PCS	Leg Support 1 PC	Pedestal Support 1 PC	Bench Support 4 PCS

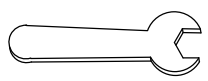
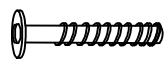
HARDWARE LIST

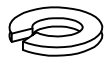
<p>#1</p>  <p>5/16"</p>	<p>#2</p>  <p>5/16"</p>	<p>#3</p>  <p>5/16"x22"</p>	<p>#4</p>  <p>12.8mm</p>	<p>#5</p>  <p>M6 x 50mm</p>
<p>Hex Nut 6 PCS (Extra 1)</p>	<p>Spring Washer 6 PCS (Extra 1)</p>	<p>Flat Washer 6 PCS (Extra 1)</p>	<p>Wrench 1 PC</p>	<p>Bolt 8 PCS (Extra 1)</p>

<p>#6</p>  <p>1/4"</p>	<p>#7</p>  <p>M6 x 13mm</p>	<p>#8</p>  <p>M4</p>
<p>Small Spring Washer 8 PCS (Extra 1)</p>	<p>Small Flat Washer 8 PCS (Extra 1)</p>	<p>Allen Wrench 1 PC</p>

Step 1 . Attach pedestal support (part D) to legs (part B) using flat washers (part #3) , spring washers (part #2), hex nuts (part #1) and wrench (part #4).

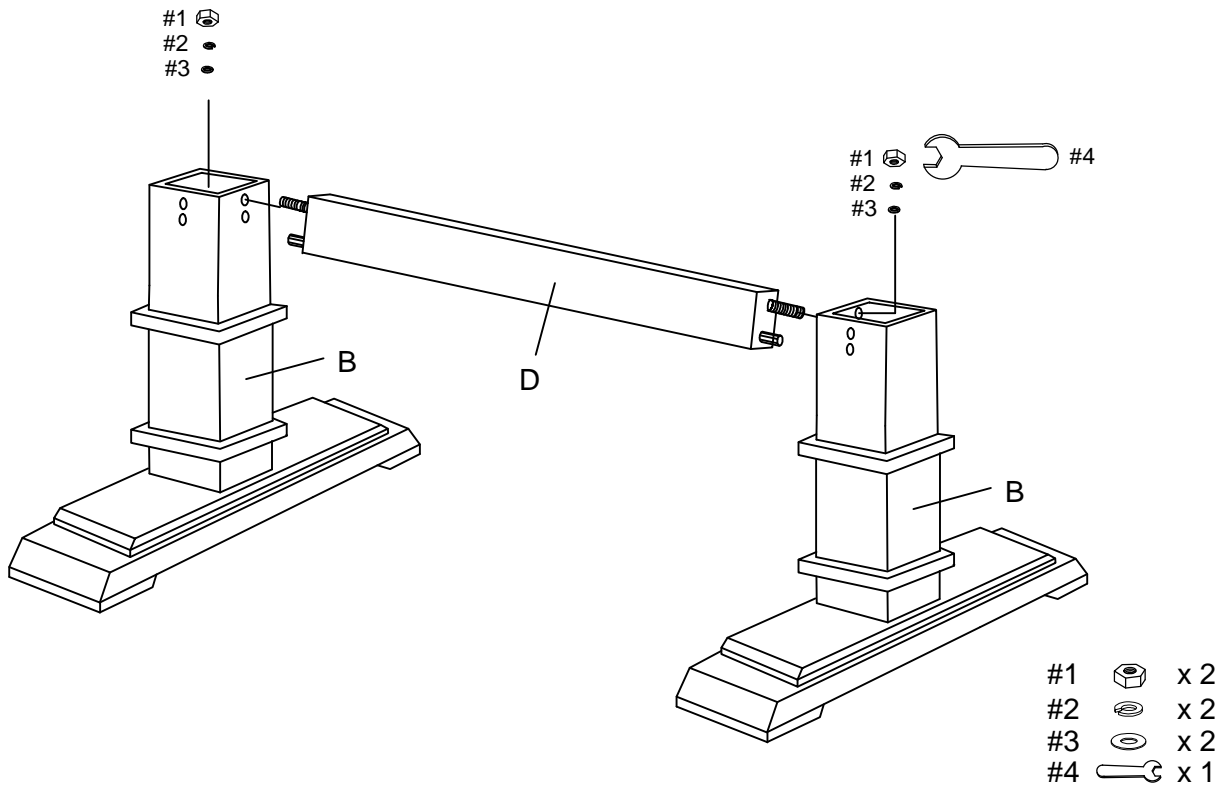

Step 2 . Attach bench supports (part E) to legs (part B) using flat washers (part #3), spring washers (part #2), hex nuts (part #1) and wrench (part #4).

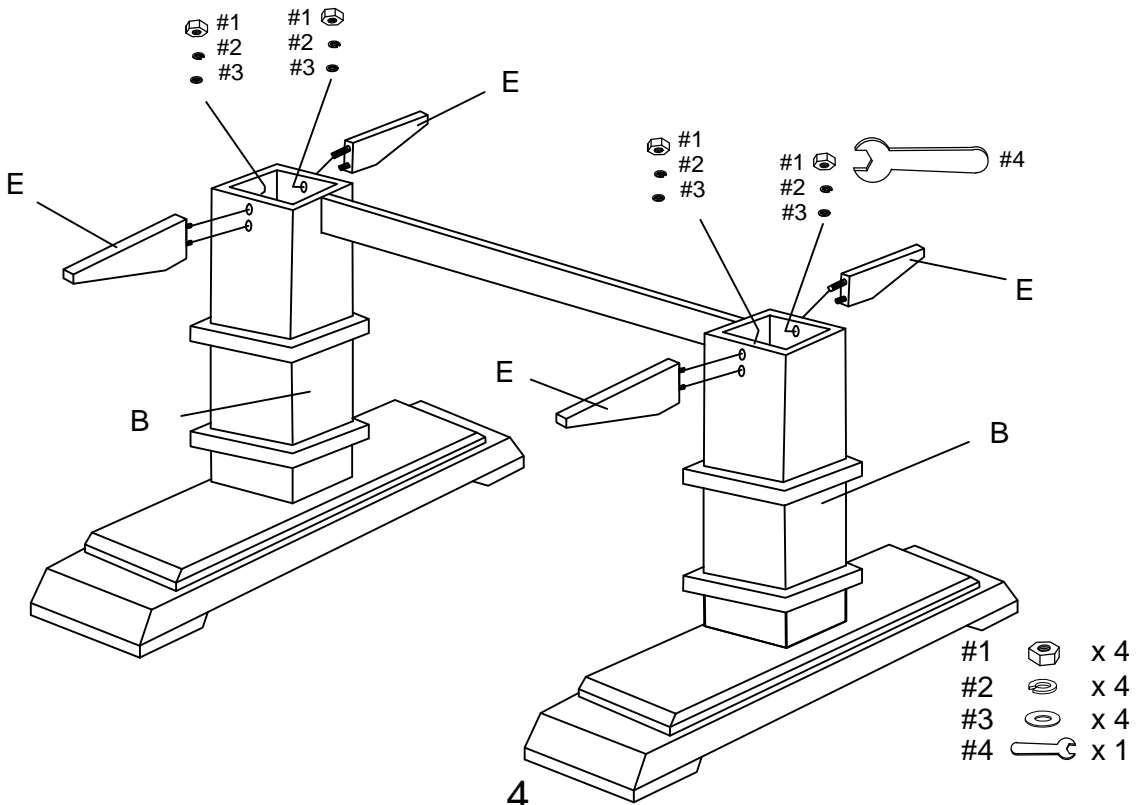

Step 3 . Lay assembled unit (parts B, D & E) upside down on soft surface, such as carpet. Attach leg support (part C) to legs (part B) using small flat washers (part #7), small spring washers (part #6), bolts (part #5) and allen wrench (part #8).

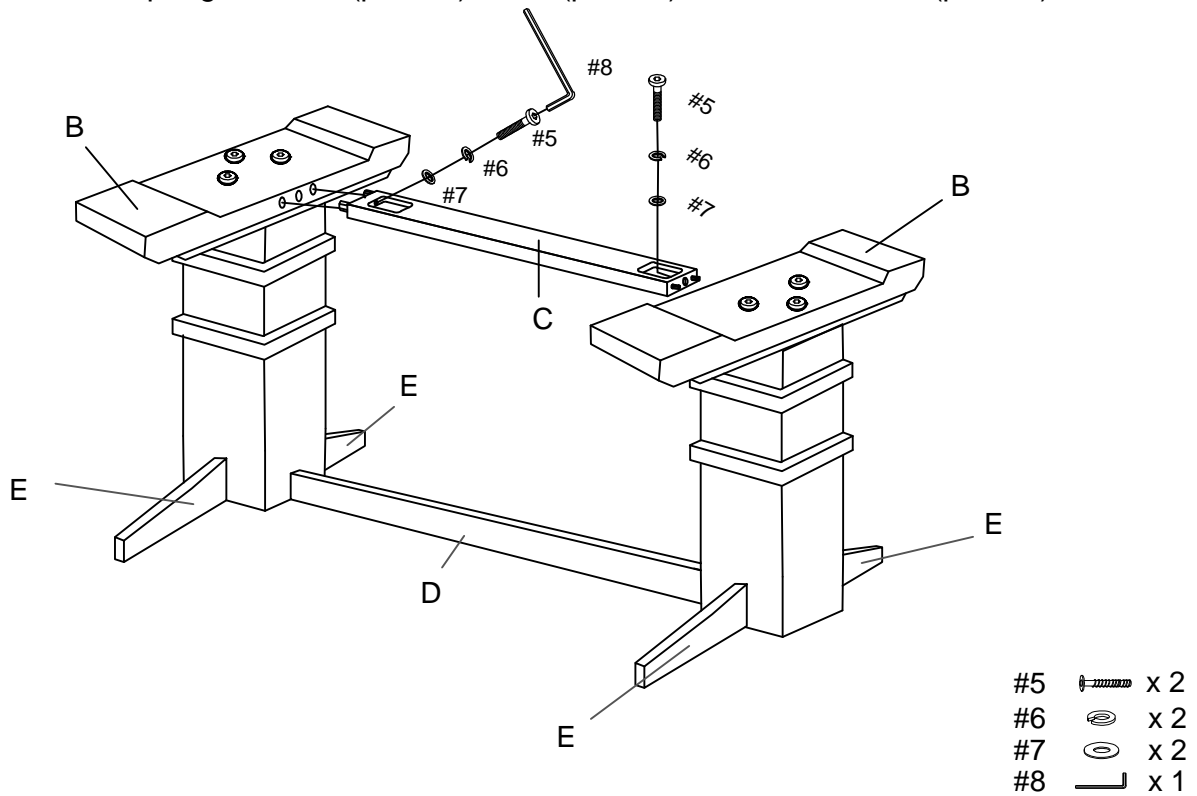

Step 4. Lay seat panel (part A) upside down on soft surface, such as carpet. Attach assembled unit (parts B, D & E) to seat panel (part A) using small flat washers (part #7), small spring washers (part #6), bolts (part #5) and allen wrench (part #8).

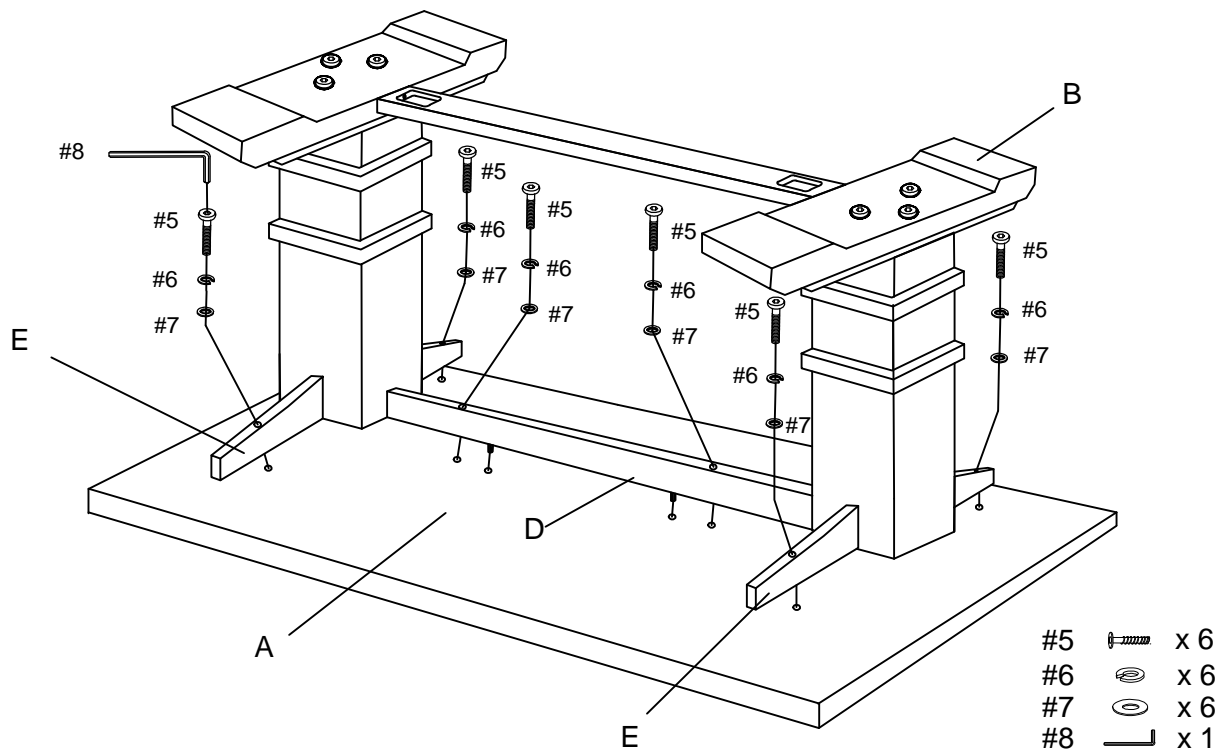

Step 5 . Carefully turn assembled unit upright.

