

[www.swisherinc.com](http://www.swisherinc.com)

# OWNER'S MANUAL

**MODEL NO.**

**22340**

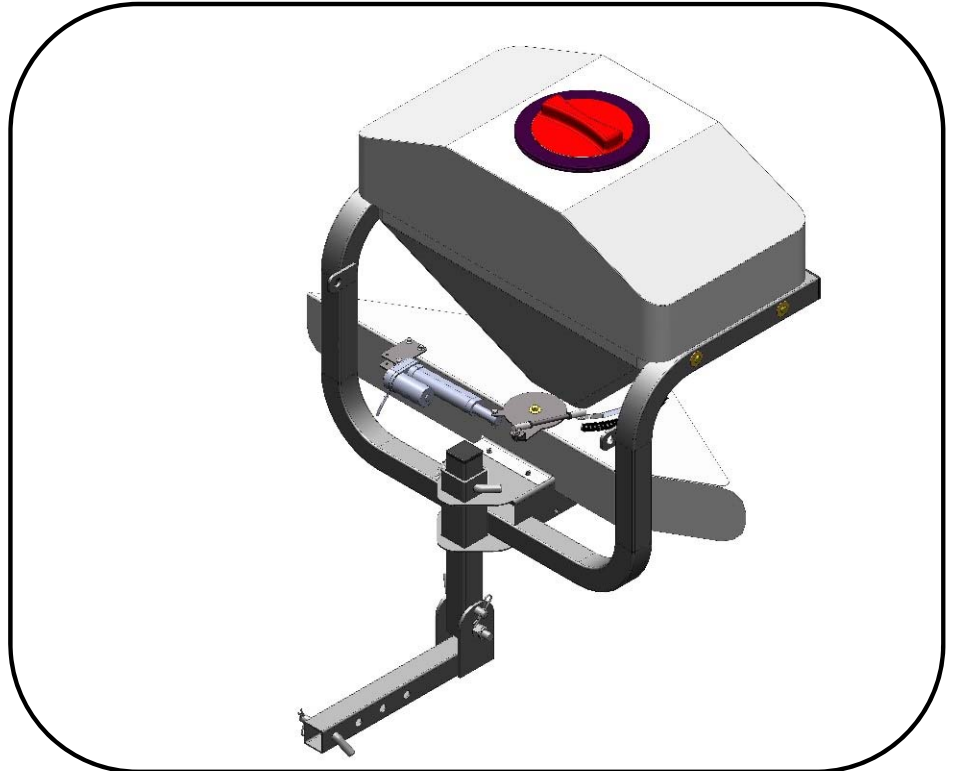
**STARTING SERIAL #:**

**L122-315001**



**IMPORTANT**

**Read and follow all  
Safety Precautions  
and Instructions  
before operating this  
equipment.**



# **COMMERCIAL PRO** **TRUCK** **SPREADER**

- **Uncrating**
- **Assembly**
- **Operation**
- **Service and Adjustment**
- **Repair Parts**

# **SWISHER<sup>®</sup>**

**10/26/2022**

SWISHER ACQUISITION INC.  
1602 CORPORATE DRIVE, WARRENSBURG, MISSOURI 64093  
PHONE (660) 747-8183 FAX (660) 747-8650

*Made In The*

**USA**

*of US and Global Parts*

# LIMITED WARRANTY

---

The manufacturer's warranty to the original consumer purchaser is: This product is free from defects in materials and workmanship for the period's shown below beginning from the date of purchase by the original consumer purchaser. We will repair or replace, at our discretion, parts found to be defective due to materials or workmanship. This warranty is subject to the following limitations and exclusions:

**1) Commercial & Consumer Use**

This product has a 1 year Limited Commercial and Consumer warranty from the date of purchase.

**2) Limitation**

This warranty applies only to products, which have been properly assembled, adjusted, and operated in accordance with the instructions contained within this manual. This warranty does not apply to any product of Swisher that has been subject to alteration, misuse, abuse, improper assembly or installation, shipping damage, or to normal wear of the product.

**3) Exclusions**

Excluded from this warranty are normal wear, normal adjustments, and normal maintenance.

In the event you have a claim under this warranty, you must return the product to an authorized service dealer. All transportation charges, damage, or loss incurred during transportation of parts submitted for replacement or repair under this warranty shall be borne by the purchaser. Should you have any questions concerning this warranty, please contact us toll-free at 1-800-222-8183. The model number, serial number, date of purchase, and the name of the authorized Swisher dealer from whom you purchased the Spreader will be needed before any warranty claim can be processed.

THIS WARRANTY DOES NOT APPLY TO ANY INCIDENTAL OR CONSEQUENTIAL DAMAGES AND ANY IMPLIED WARRANTIES ARE LIMITED TO THE SAME TIME PERIODS STATED HEREIN FOR ALL EXPRESSED WARRANTIES. Some states do not allow the limitation of consequential damages or limitations on how long an implied warranty may last, so the above limitations or exclusions may not apply to you. This warranty gives you specific legal rights and you may have other rights, which vary from state-to-state. This is a limited warranty as defined by the Magnuson-Moss Act of 1975.

# TABLE OF CONTENTS

---

•	<b>SAFETY PRECAUTIONS</b> .....	4
•	<b>SPECIFICATIONS</b> .....	5
•	<b>SAFETY AND OPERATION DECALS</b> .....	6
•	<b>UNPACKING</b> .....	7
•	<b>KNOW YOUR SPREADER</b> .....	8
•	<b>SPREADER &amp; VEHICLE SET UP</b> .....	9-11
•	<b>CONTROLS</b> .....	12
•	<b>GETTING STARTED</b> .....	13
•	<b>GENERAL OPERATIONS</b> .....	14-16
	- GENERAL RECOMMENDATIONS	
	- GETTING STARTED	
	- FILLING THE HOPPER	
	- SPREADING RECOMMENDATIONS	
	- SPREAD PATTERN ADJUSTMENT	
	- BEFORE YOU START SPREADING	
	- GENERAL SPREADING	
	- SPREAD ZONE COVERAGE	
•	<b>SPREADER MAINTENANCE</b> .....	17
	- GENERAL RECOMMENDATIONS	
	- BEFORE EACH SEASON	
	- BEFORE EACH USE	
	- AFTER EACH USE	
•	<b>CLEANING GUIDELINES</b> .....	18
•	<b>TROUBLESHOOTING</b> .....	19
•	<b>WIRING DIAGRAM</b> .....	20-22
•	<b>PARTS DIAGRAMS</b> .....	23-29
	- SPINNER DISC ASSEMBLY	
	- RECEIVER ASSEMBLY	
	- CONTROL BOX ASSEMBLY	
	- ACTUATOR ASSEMBLY	
	- HOPPER ASSEMBLY	
	- MAIN FRAME ASSEMBLY	
	- AGITATOR & HOPPER MOUNTING	
•	<b>CALCULATING MATERIAL FLOW</b> .....	30-31
•	<b>SPREADER LOG NOTES</b> .....	32-34
•	<b>TORQUE SPECIFICATIONS REFERENCE GUIDE</b> .....	35

# SAFETY PRECAUTIONS

Thank you for choosing Swisher's Commercial Pro Truck Spreader. Before operating your Spreader, please read, understand and follow all of the safety precautions and other instructions explained in this manual. As with all power equipment Spreaders can be potentially dangerous if improperly used.



**This Safety Alert Symbol indicates important messages in this manual. When you see this symbol, carefully read the message that follows and be alert to the possibility of personal injury.**

**Read this manual completely. This machine can injure hands and legs, and throw objects. Failure to observe the following safety instructions could result in serious injury or death.**

- Read the manual. Learn to operate this machine safely.
- Keep all shields and guards in place.
- Know the operations of all controls before you operate this machine. Check all of the controls in a safe area before starting to work with this machine.
- Allow only responsible adults who are familiar with these instructions to operate this machine. **Never allow children to operate this machine.**
- Be sure the area is clear of other people before spreading. **Stop the machine** if anyone enters the spreading area. Children are often attracted to the machine and the spreading activity. **Never assume that children will remain where you last saw them.** Keep children under the watchful care of another responsible adult.
- **No riders!**
- Do not put hands or feet near or under rotating parts.
- **Watch for traffic** when operating near or crossing roadways.
- Do not operate the Spreader if it has been dropped or damaged in any manner or if the Spreader vibrates excessively. **Excessive vibration is an indication of damage.** Repair Spreader as necessary.
- Use proper handling procedures for the material you are using. Obey all safety precautions advised by the material manufacturer.
- Dress properly. Protect skin and body parts from flying material and dust.
- Do not operate the machine while under the influence of alcohol or drugs.
- Volume of material and weight of material vary by the material's density. Always pay attention to the **amount of weight** you are putting into the Hopper. **Do not exceed the 300 lb. capacity.** Some materials will reach 300 lbs before the Hopper is full.

# SPECIFICATIONS

	<b>Description</b>
<b>Spreader Motor</b>	1/3 HP 12 VDC Commercial Electric Gearbox
<b>Overall Dimesions</b>	41"H X 40"W X 21.5"L
<b>Unit Dry Weight</b>	89 lbs.
<b>Spreading Width</b>	Up to 35ft
<b>Hopper Capacity by Weight</b>	300 lbs
<b>Hopper Capacity by Volume</b>	3.3 cu. ft. / 25 gal.
<b>Hitch Class</b>	Class III
<b>Quick Reference - Maintenance Parts</b>	
<b>Description</b>	<b>Part Number</b>
<b>Washer - Plastic, 5/8" ID</b>	22225
<b>Fin - Spinner Disc</b>	22202GV
<b>Agitator Head</b>	22230GV
<b>Cotter Pin - Agitator Shaft</b>	19036
<b>Agitator Spring</b>	22260

**Note:**

- For other part numbers, refer to the Parts Diagrams on pages 20-26.

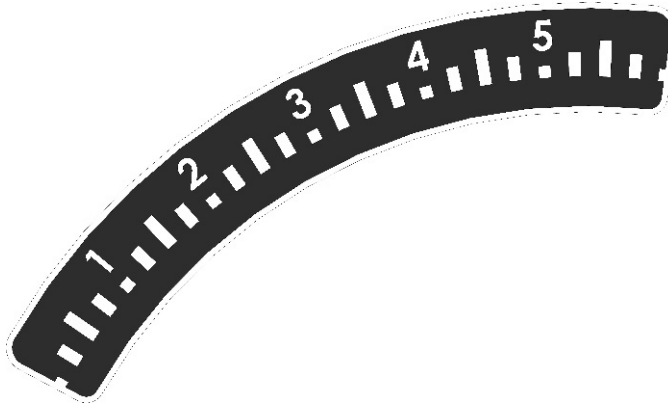


# SAFETY AND OPERATION DECALS

Replace decal immediately if damaged.



12284- DRY MATERIAL DECAL



22411- OPENING INDICATOR DECAL



OD55 DANGER KEEP AWAY



21977- FLYING DEBRIS DECAL

# UNPACKING/CONTENTS



**Use care  
when  
unpacking.**

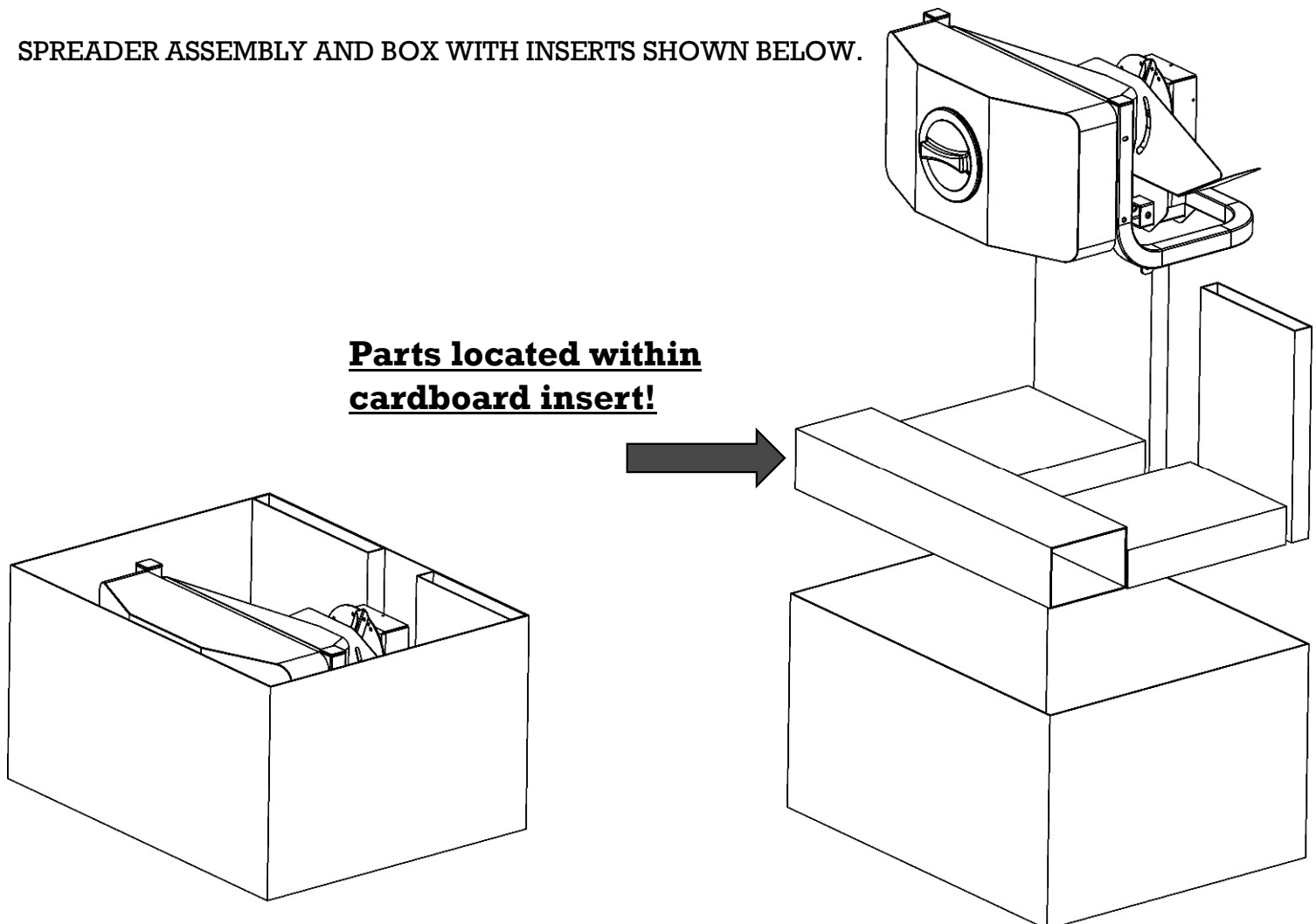
## **BOX CONTENTS:**

- Main Spreader Assembly including Harness.
- Parts located within the Main Spreader Hopper:
  - (2) Securing Straps.
  - User's Manual.
  - Quick Ties for mounting Wiring Harness
- Parts located within cardboard insert:
  - Receiver Assembly with hardware (shown on page 24).

## **UNPACKING:**

- Remove the Main Spreader Assembly from the packaging by carefully lifting up out of the box or cutting the box down from around it.
- Remove all contents from within the Hopper.
- Verify all components are accounted for that are listed in the Contents List shown above.

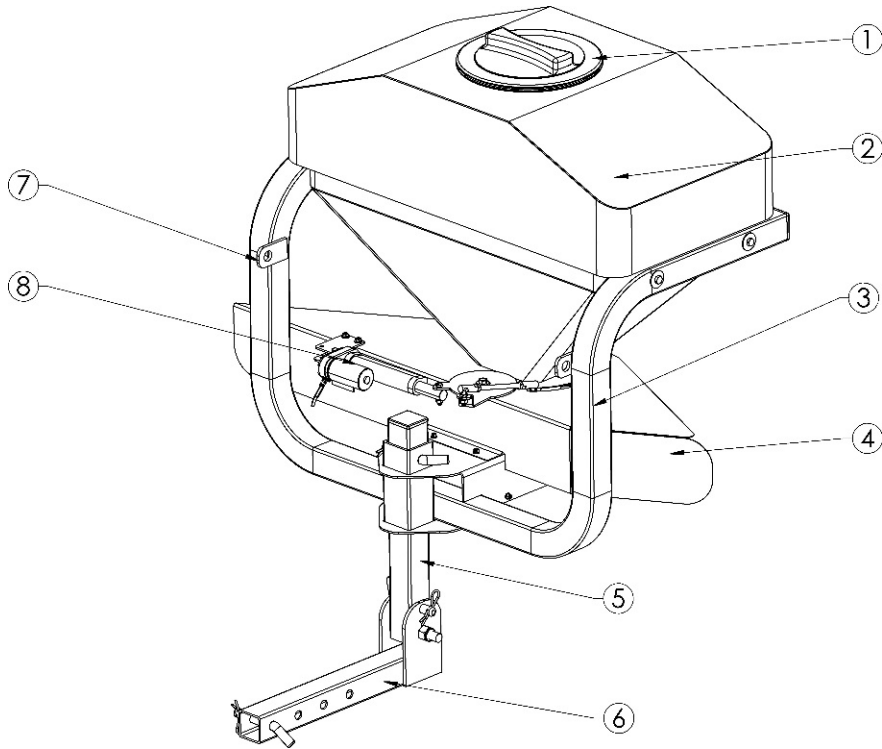
SPREADER ASSEMBLY AND BOX WITH INSERTS SHOWN BELOW.



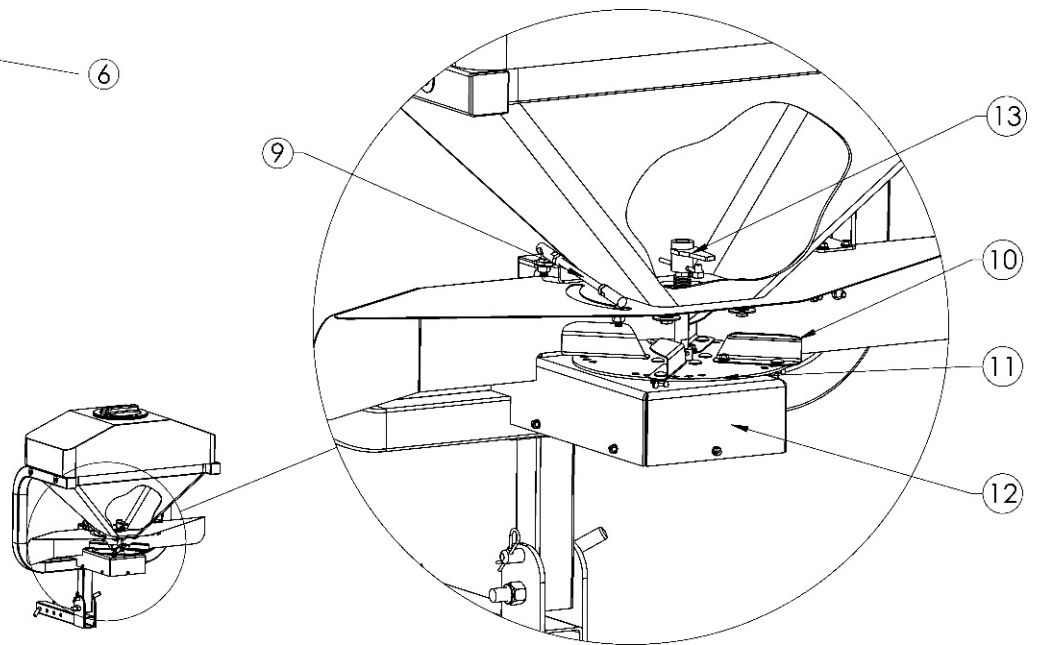
# KNOW YOUR SPREADER



It is important to know the features of the Spreader. Please review the entire manual for detailed operational and safety information.



- ① Vented Lid
- ② Poly Material Hopper
- ③ Powder Coated Main Frame
- ④ Galvanized Steel Material Shield
- ⑤ Adjustable Height Frame Tube
- ⑥ 2" Adjustable Hitch Bar
- ⑦ Strap Mount
- ⑧ Electric Flow Gate Actuator



- ⑨ Adjustable Gate Linkage
- ⑩ Adjustable Galvanized Steel Material Fin
- ⑪ Galvanized Steel Spinner Disc
- ⑫ Motor Enclosure
- ⑬ Galvanized Steel Agitator



# SPREADER & VEHICLE SET UP



**WARNING:** ALWAYS SET THE PARKING BRAKE ON THE VEHICLE BEFORE INSTALLING OR GETTING OUT OF VEHICLE TO WORK WITH SPREADER.

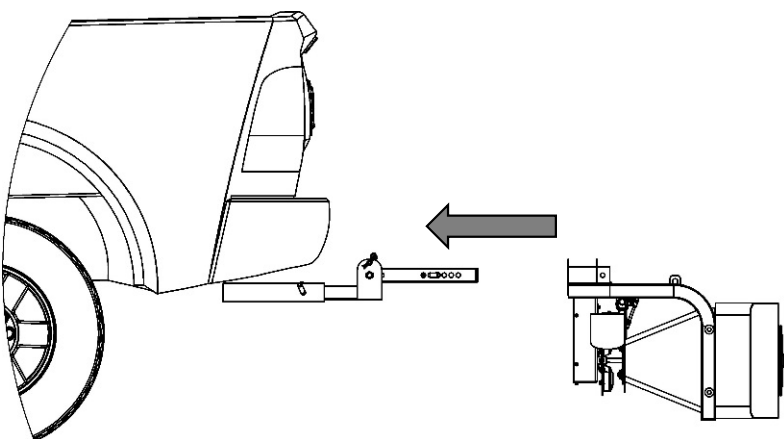
## VEHICLE HITCH REQUIREMENTS:

- 2", MINIMUM CLASS III RECEIVER

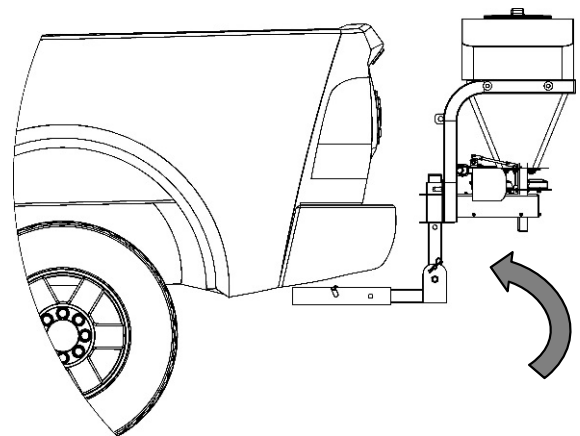
## MOUNTING THE SPREADER TO YOUR VEHICLE

1. Place the Receiver Assembly into your vehicle's Receiver Tube in the orientation shown below in **FIGURE 9.1**. There are multiple pin locations in the Receiver Tube to accommodate most types of vehicles in regard to clearance between the spreader and vehicle. Ensure the Receiver Assembly is properly pinned/secured once in the desired location using the supplied 5/8" Pin (NB702) provided.
2. With the hopper facing Spinner Disc side down, slide the Spreader Assembly onto the Receiver Assembly as shown in **FIGURE 9.1**, and pin with supplied 5/8" Pin (NB702) at the desired location. Multiple holes are provided for Height Adjustment on the Height Adjust Frame Tube to accommodate most vehicle heights.
3. Once the desired placement of the hopper is set, rotate the Spreader Assembly upward towards the vehicle and secure by pinning the assembly at the pivot point with the supplied 5/8" Pin (NB702). **FIGURE 9.2**.

CONTINUED ON NEXT PAGE.



**FIGURE 9.1**



**FIGURE 9.2**

# SPREADER & VEHICLE SET UP



**WARNING:** ALWAYS SET THE PARKING BRAKE ON THE VEHICLE BEFORE INSTALLING OR GETTING OUT OF VEHICLE TO WORK WITH SPREADER.

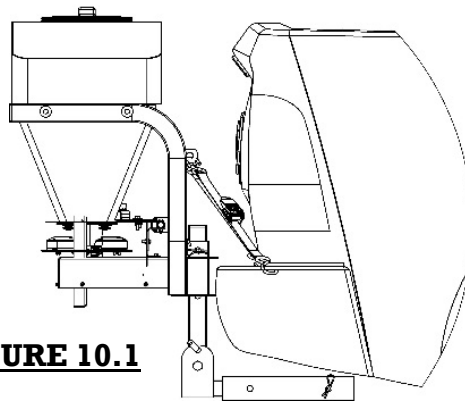
4. After the Spreader is mounted vertically, finish securing the Spreader by attaching the (2) Adjustable Straps provided. Tighten the straps until the Spreader is rigid with the vehicle. This will help fix the Spreader rigid to the vehicle. Suggestions on mounting locations shown in **FIGURE 10.1**, **FIGURE 10.2** & **FIGURE 10.3**.

**NOTE:**

- Most vehicles come with tie down locations within the bed.
- Strapping to factory tie down locations (**FIGURE 10.1**) or rigid parts of the vehicles bumper (**FIGURE 10.2**) are recommended.
- For best results, strap down the Spreader Assembly prior to filling hopper with any media.

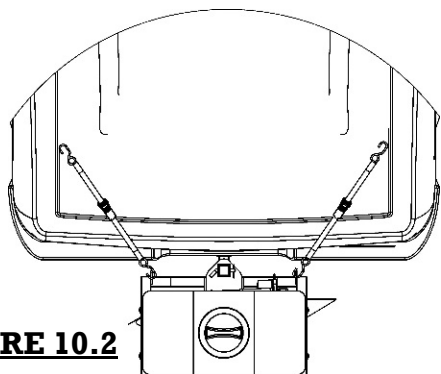
**NOTE: DO NOT OVER TIGHTEN STRAPS AND BE AWARE OF WHAT PART OF THE VEHICLE YOU ARE CONNECTING TO, SO NOT TO CAUSE DAMAGE TO THE VEHICLE.**

## SIDE VIEW OF TRUCK BED

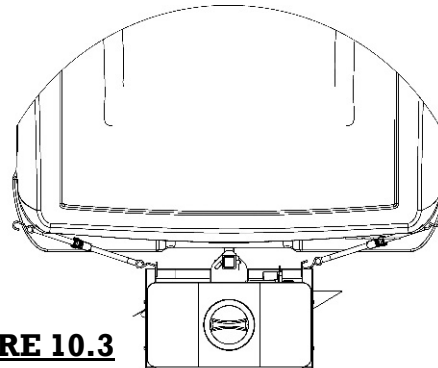


**FIGURE 10.1**

## TOP VIEW OF TRUCK BED



**FIGURE 10.2**



**FIGURE 10.3**

# SPREADER & VEHICLE SET UP CONT.



**WARNING:** ALWAYS SET THE PARKING BRAKE ON THE VEHICLE BEING USED BEFORE WORKING WITH THE EQUIPMENT TO PREVENT ACCIDENTAL MOVEMENT.

## WIRING HARNESS

The wiring harness consists of three parts. The main harness , control harness and spreader harness (shown on pages 20-22). The control harness can connect to the main harness when using in normal operation and can also connect directly to the spreader harness at the spreader when needed for programming settings or flow calculations.

## INSTALLING WIRING HARNESS

1. Lay the entire main harness out the length of the vehicle and determine where best to route and fasten the harness to the vehicle. The harness can be mounted on the under carriage of the vehicle or along the side of the vehicle.  
**NOTE: KEEP THE HARNESS CLEAR OF ALL MOVING PARTS AND EXHAUST.**  
**NOTE: IT IS NOT RECOMENDED TO DRILL HOLES IN ANY PART OF THE VEHICLE BUT IF DESIRED, SHOULD BE DONE BY A PROFESSIONAL INSTALLER**
2. Next, determine where the wire harness for the control box can enter the cab area. Use existing access through vehicle firewall, panel, window, access panel, etc. Once placement of the harness has been decided , use the quick ties provided to securely fasten the main harness to the vehicle. **Never fasten the harness to any moving components, exhaust components or parts that will effect the normal operation of the vehicle.**
3. Next, identify the positive and negative terminals on the vehicle's battery. (Some vehicles will have auxiliary positive posts that can be utilized.) Not all batteries are the same and widely vary so adapters or add-on terminals may be required to adapt to a **3/8" diameter stud or smaller.** With the vehicle turned off, engine cool, parking brake engaged and on level ground, install the red wires to the positive terminals first and then the black wires to the negative terminals. Verify the spreader motor works properly by turning on the spreader motor and verifying the spinner is turning clockwise looking from above the spinner disc. Using the gate controls, verify the actuator runs in and out and the gate fully opens and closes. (SEE CONTROLS ON NEXT PAGE.)

## STORAGE

When the spreader is not in use, the control harness and spreader harness can be unplugged from the main harness and the spreader may be removed until the next use.

**NOTE :** It is recommended to cover the receptacles on the main harness if possible to protect from debris getting in them while when the spreader is not installed. Dielectric grease should be applied if possible to the connectors to help against possible corrosion.

# CONTROLS

## CONTROL PROGRAMMING AND USE

The control for the Hopper Gate is located on the Main Control Box. It opens and closes the Gate and has up to 3 programmable presets.

### OPERATIONS / PROGRAMMING:

To turn the Spreader Disc on and off flip the toggle switch located on the Control Box up or down as seen in **FIGURE 12.1**.

#### **To open and close Hopper Gate:**

1. Press and hold buttons 2 & 3 at the same time to close the Gate. Releasing the buttons will stop the Gate.

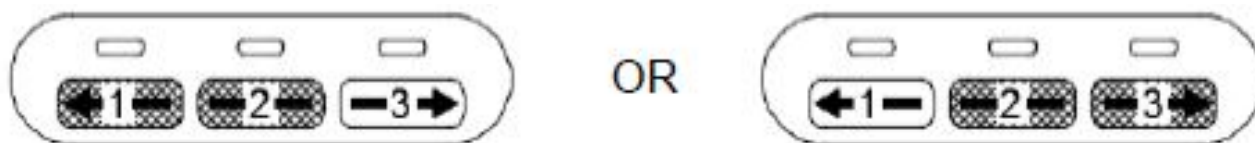


2. Press and hold buttons 1 & 2 at the same time to open the gate. Releasing the buttons will stop the Gate.

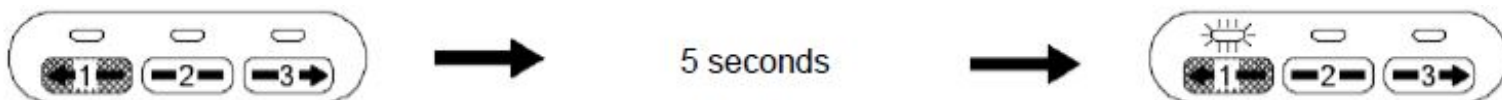


#### **To program preset positions 1, 2, and 3:**

1. Position the Hopper Gate where you would like Preset #1 to be located by opening or closing the Gate as shown in previous steps.



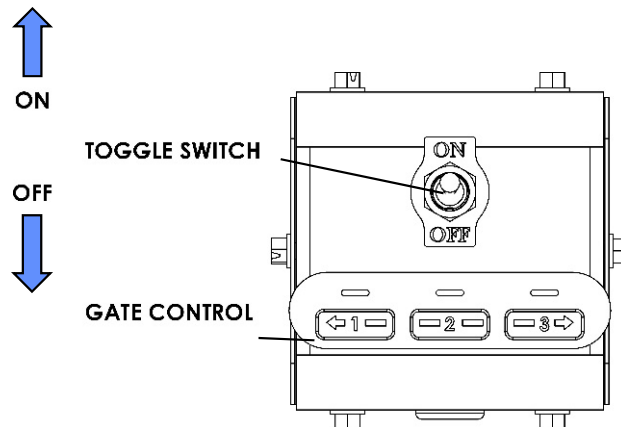
2. Press and hold the number 1 button for 5 seconds.
  1. The LED will flash to indicate the setting has been learned and stored.



Repeat steps 1 & 2 to program Presets #2 & #3.

### OPERATION NOTES:

- The control unit will remember the preset positions after its power is removed.
- Programming a new preset position will overwrite any previous preset position stored for that button number.
- The presets can be in any position throughout the stroke of the actuator. They do not need to be in order along the travel of the actuator stroke. They do not need to be programmed in any certain order.



**FIGURE 12.1**

# GETTING STARTED



The operation of any spreader can produce foreign objects that can be thrown into the eyes, resulting in severe eye damage. Always wear certified safety glasses or wide-vision safety goggles over spectacles when standing near a spinning spreader disc.



**CAUTION!** Tragic accidents can occur if the operator is not alert to the presence of children. Children are often attracted to the machine. ***Never assume that children will remain where you last saw them.***



Always inspect the Spreader before each use. Ensure all hardware is tight and all moving parts are in proper working order. Machine damage and/or injury can occur if Spreader operates with defective parts.



The Spreader has high speed components and throws debris a long distance. Always make sure no one is within 100 feet of the spreader when in use. Stop use if someone approaches spreader.

## **BASIC SPREADER CONCEPTS**

Your truck spreader uses the centrifugal force from a spinning disc to “spread” material. The spinner disc is connected to a gearbox that is powered by a 12 volt source from the vehicle. Heavier coverage of material will be obtained when traveling slower speeds as lighter coverage will be obtained by traveling at faster speeds. In addition to traveling speed the material flow can be regulated by the gate opening which will determine volume of coverage as well.

## **INTENDED USE**

Your Truck Spreader should be mounted to a truck or similar vehicle’s 2” Class III Hitch.

## **MANUAL TERMINOLOGY**

- Refer to the “KNOW YOUR SPREADER” section for a brief overview of the spreader components.
- “Material” refers to the product that is being spread (e.g. grass seed, sand, salt etc...)
- **FIGURE** references used throughout reflect the page number as the first number( e.g. **FIGURE 20.1** is on page 20, **FIGURE 15.2** is on page 15, etc...).

# GENERAL OPERATIONS



*Always inspect the Spreader before each use. Ensure all hardware is tight and all moving parts are in proper working order. Machine damage and/or injury can occur if Spreader operates with defective parts.*



## **GENERAL RECOMMENDATIONS**

- Learn and refer to all safety warnings in this manual before operating the Spreader.
- If Spreader is being used on or near a roadway always follow local laws and regulations.

## **GETTING STARTED**

- Is it important to learn all the operations discussed in this manual before starting.
- Decide whether or not the Agitator Head is to be used before filling the Hopper. The Agitator can cause damage to some coated and/or delicate seeds. **Calculate the flow rate of the material to be spread for the most accurate results.**
- Ensure the Flow Gate is closed prior to filling.



**300 LB**  
**HOPPER CAPACITY**



## **FILLING THE HOPPER**



- **Make sure the Spreader is securely connected to the Vehicle.**



- **Always fill the Hopper at the site where the material is to be spread. Traveling with a full Hopper will cause the material to compact and can result in poor spreading.**
- The recommended method of filling the Spreader is to place the **unopened** bag of material on the top ledge of the Hopper with the Hopper in the vertical position. Place the end of the bag to be opened into the opening of the Hopper. Open the bag and let the material fall into the Hopper by lifting the opposite end of the bag. Repeat this step until the desired amount of material is in the Hopper and then replace the Hopper Lid.

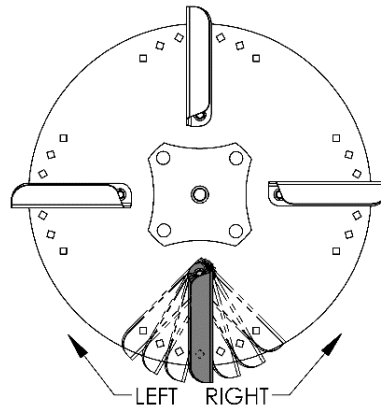
## **SPREADING RECOMMENDATIONS**

- When spreading the first pass, take note of the distribution pattern.
- Pay close attention to your speed, as this will directly impact the spread volume on the coverage area. The faster you go, the thinner the coverage will become. The slower you go, the thicker the coverage area will become. It is important to maintain a consistent speed for even coverage.
- If the pattern seems to be uneven or applies material heavier in one direction then follow the instructions for FINE TUNING THE SPREAD PATTERN on page 14.

# SPREAD PATTERN ADJUSTMENT

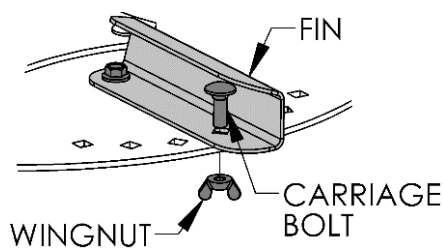
## FINE TUNNING SPREAD PATTERN

- The adjustable Fins will let you fine tune the spread pattern. Move the Fins in the direction that you want more material to be applied (e.g. If the material is spreading too heavy to the left then move the Fins to the right for the spread to become heavy on the right). See **FIGURE 15.1**.
- **Note: When you move fins to the left this will lessen the distance the material is thrown. When the fins are set towards the Right this will increase the distance the material is thrown.**



**FIGURE 15.1**

- To adjust the fins, remove the Wing Nut and Carriage Bolt that connected the Fin to the Spinner Disc. The Fin should now be free to pivot around the rear bolt.



**FIGURE 15.2**

- Adjust the Fin in the desired direction and replace the Carriage Bolt and Wing Nut.

# GENERAL OPERATIONS

## BEFORE YOU START

- *It is strongly recommended to calculate the spread pattern and flow rates of the material you will be spreading. If you do not do this, the spreader may not produce desired results. See pages 30-31 for flow rate calculation procedures.*

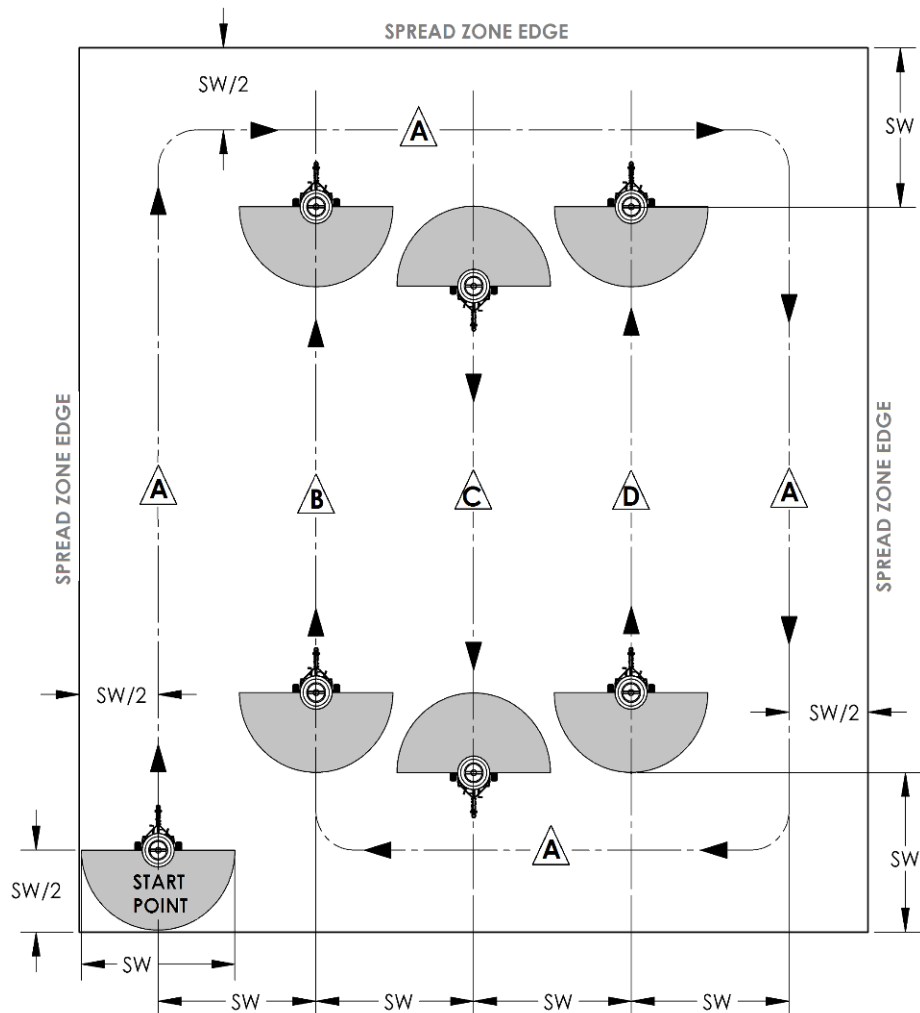
## SPREADING

- There are many effective ways to use the spreader. The following guideline is a suggested way to ensure even coverage.
- For best results, it is recommended to set the flow rate at half of the desired coverage and cover the area twice. The second coverage route should be perpendicular to the first coverage route. This is the best method to achieve even coverage with lower chances of thin or missed spots.

## SPREAD ZONE COVERAGE

See **FIGURE 16.1**

1. Position the Spreader in the corner of the area to be covered as indicated by the "START POINT" at half the spread width from both edges of the spread area.
2. Open gates to the desired flow rate setting and begin moving forward at the required speed along route "A". Route "A" will continue around the perimeter at a Half Spread Width distance from the edge of area.
3. Once you are a distance of  $SW/2$  from the "Start Point", turn to continue along route "B". Route "B" and route "A" should be a Spread Width apart. Make sure to not leave a gap between route "A" and "B".
4. When you reach route "A" close the gate and turn the unit to go in the opposite direction along route "C".
5. Once you are aligned with route "C" and are a distant of one spread width from the edge, reopen the gate and travel straight along Route "C". Again, ensure there is no gap between route "B" & "C".
6. Repeat Steps 4 & 5 until you have covered the entire area.



**FIGURE 16.1**

"SW" = Spread Width  
"SW/2" = Half Spread Width



# SPREADER MAINTENANCE

---

## **GENERAL RECOMMENDATIONS**

The warranty on this Spreader does **not** cover items that have been subjected to operator abuse or negligence. To receive full value from the warranty, operator must maintain the spreader as instructed in this manual. Some adjustments will need to be made periodically to maintain your unit properly.

## **BEFORE EACH SEASON**

- Check the UHMW Washer (Part Number 22225) for wear, replace if needed. See **Page 29**
- Check The Operation of The Controls.
- Replace The Agitator Cotter Pin (Part Number 19036). See **Page 29**

## **BEFORE EACH USE**

- Check all Hardware for Looseness or Damage.
- Inspect Wiring Harness for any damage.

## **AFTER EACH USE**

- Check all Hardware for Looseness or Damage.
- **Clean Thoroughly.** Clean inside of Hopper and all exterior components. Refer to **Page 18** for cleaning

NOTE: NEVER USE HIGH PRESSURE WATER ON MOTOR ENCLOSURE.

**Important: Replace parts that have been damaged.**

**Important: Check Disc and Hopper mounting hardware on a regular basis to make sure it is tight.**



**CAUTION: CARELESS OR IMPROPER HANDLING MAY RESULT IN SERIOUS INJURY.**

# CLEANING GUIDELINES



**WARNING:** PROPER CLEANING IS ONE OF THE MOST IMPORTANT STEPS IN CARING FOR YOUR SPREADER. SOME MATERIALS CAN BE HIGHLY CORROSIVE AND **WILL** CAUSE DAMAGE TO SPREADER COMPONENTS IF NOT CLEANED!



**WARNING:** NEVER SPRAY WATER INSIDE SPREADER MOTOR ENCLOSURE! ONLY SPRAY WATER ON PARTS THAT ARE EXPOSED TO MEDIA. SPRAYING WATER WITHIN THE COMPARTMENT CAN DAMAGE ELECTRICAL COMPONENTS.

## **GENERAL RECOMMENDATIONS**

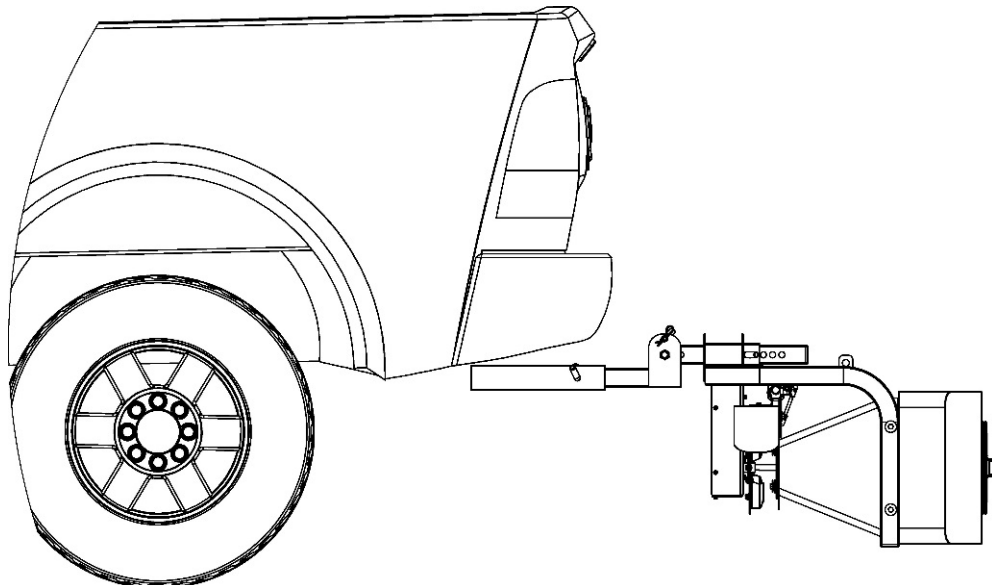
- Always thoroughly clean the spreader after every use.
- Use fresh clean water to clean.
- Allow to completely dry before using.

## **CLEANING THE HOPPER**

- Empty all material left in the Hopper.
- Unlatch both secure straps and **CAREFULLY** unpin and lower Spreader Assembly as shown in **FIGURE 18.1.** for ease of cleaning hopper.

**NOTE: NEVER ATTEMPT TO LOWER SPREADER ASSEMBLY WHEN NOT COMPLETELY EMPTY.**

- Using clean water and a rag. Thoroughly clean the inside of the Hopper and all Components. It may be necessary to remove the agitator to clean particles that may be trapped underneath.
- Also thoroughly clean the spinner disc and gearbox shaft.
- Check the internal plastic sealing Washer (Part # 22225) for damage and clean all debris that may have gotten under the Washer. See page 29 for Washer detail.
- Once the Hopper is clean, if cleaned with water, make sure it is completely dry before adding material. Wet material can result in poor function and corrosion.



**FIGURE 18.1**

# TROUBLESHOOTING

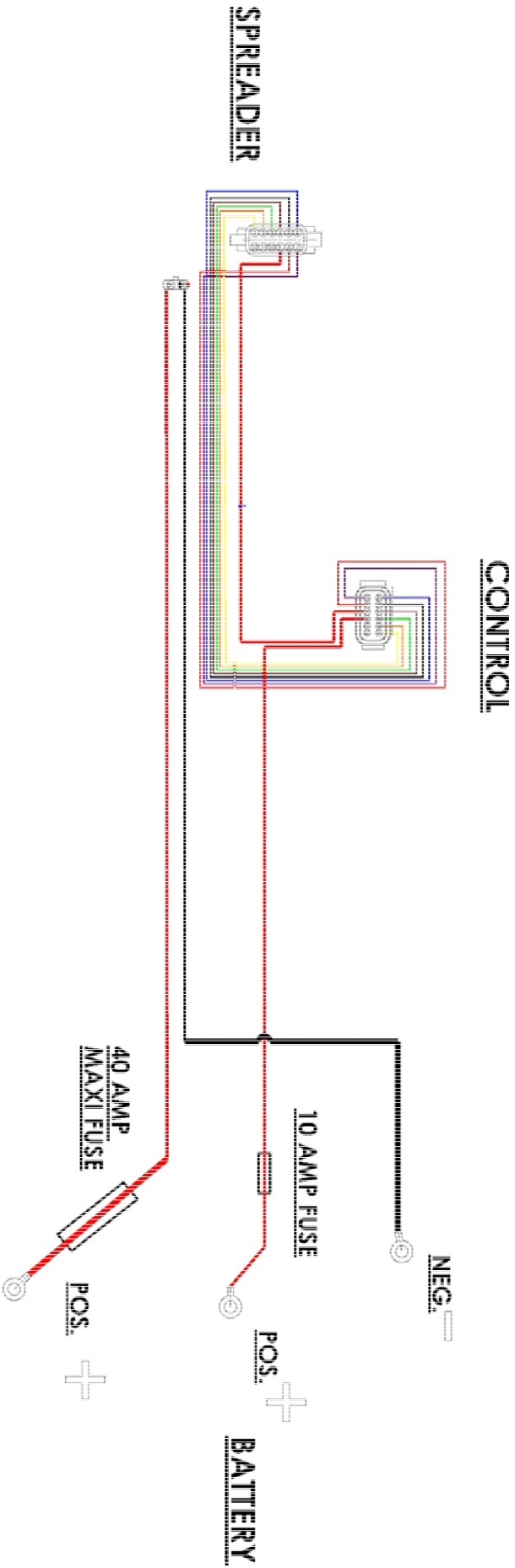
ISSUE	SOLUTION
<b>Disc Will Not Spin</b>	Check that the Harness is installed to the battery properly and supplying power.
	Ensure Pin is in the Spinner Disc Hub.
	Check Gear Box Motor For Damage.
	Check for Material Jamming the internal Agitator.
<b>Material Will Not Flow</b>	Check that the Flow Gate is Open to the desired Opening.
	Check Linkage between Actuator and Flow Gate is Connected.
<b>Spreader Motor Will Not Turn On</b>	Check that the Harness is installed to the battery properly and supplying power
	Check that the Main Wiring Harness Fuses are not Blown.
	Check all wiring connection between Control Box and Spreader.
<b>Agitator Will Not Spin</b>	Check that the Cotter Pin is in place and not damaged.
	Ensure Motor shaft is not damaged or broken.
<b>Material Gate Will Not Move</b>	Check that the Fuse located in the Spreader motor Compartment is not Blown.
	Check Gate Plates for damage/blockages.
	Check Connection at control switch at the Control Box.



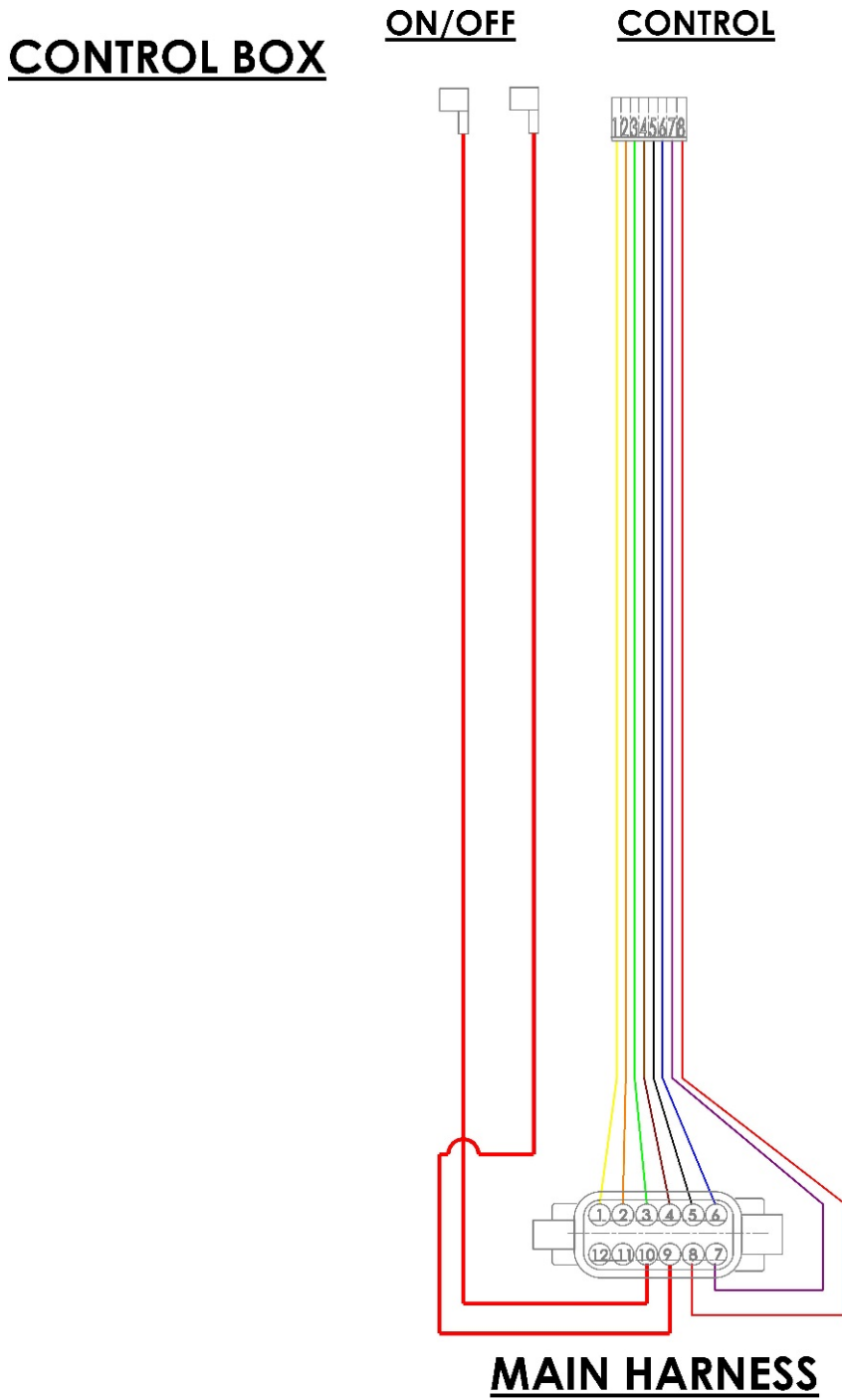
**IF PROBLEMS PERSIST HAVE A QUALIFIED MECHANIC SERVICE THE SPREADER. NEVER ATTEMPT TO MAKE AN ADJUSTMENT THAT YOU ARE NOT SURE IS CORRECT. DOING SO CAN CAUSE OTHER PROBLEMS.**

# WIRING DIAGRAM

## 22415 MAIN HARNESS



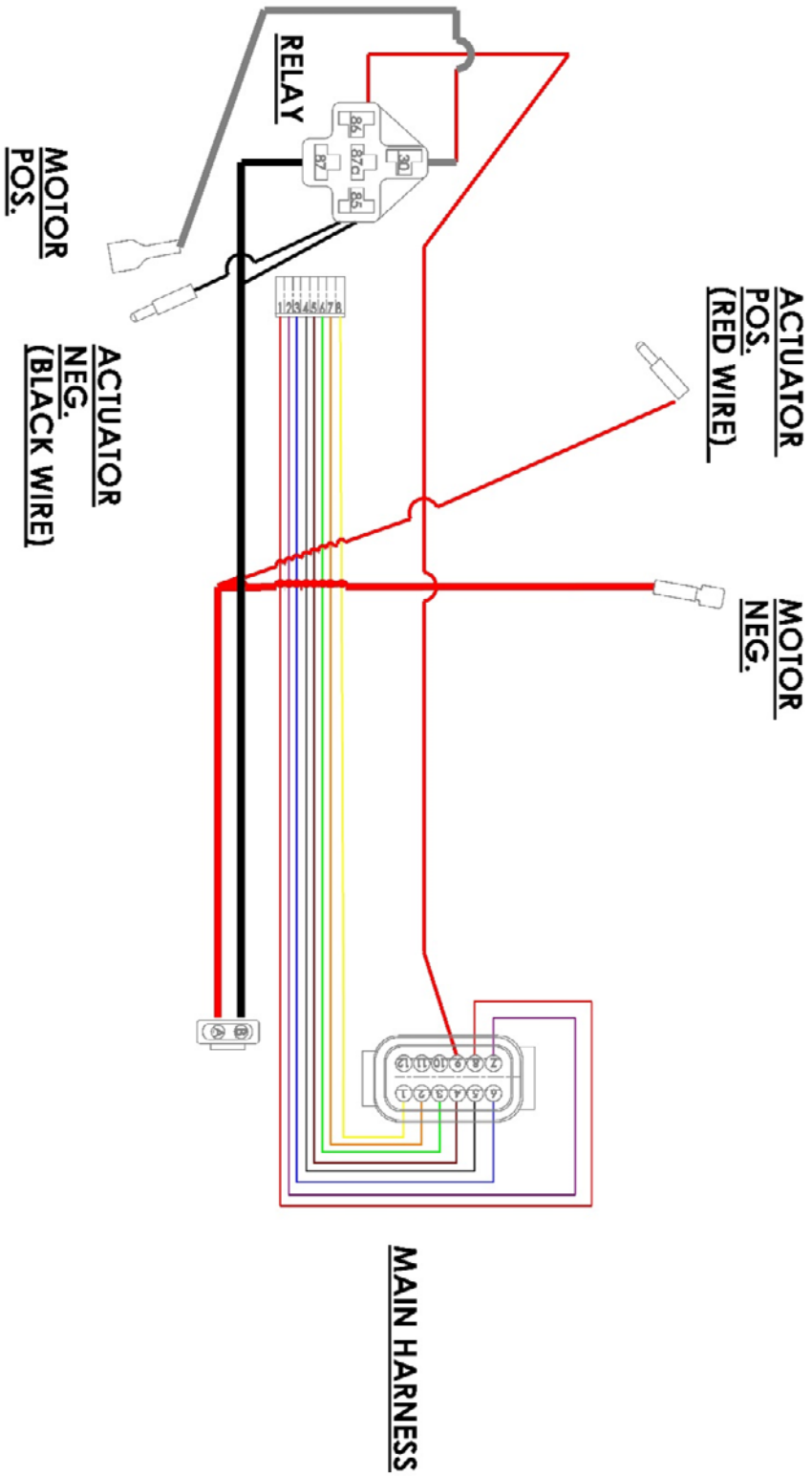
# WIRING DIAGRAM



## 22414 CONTROL HARNESS

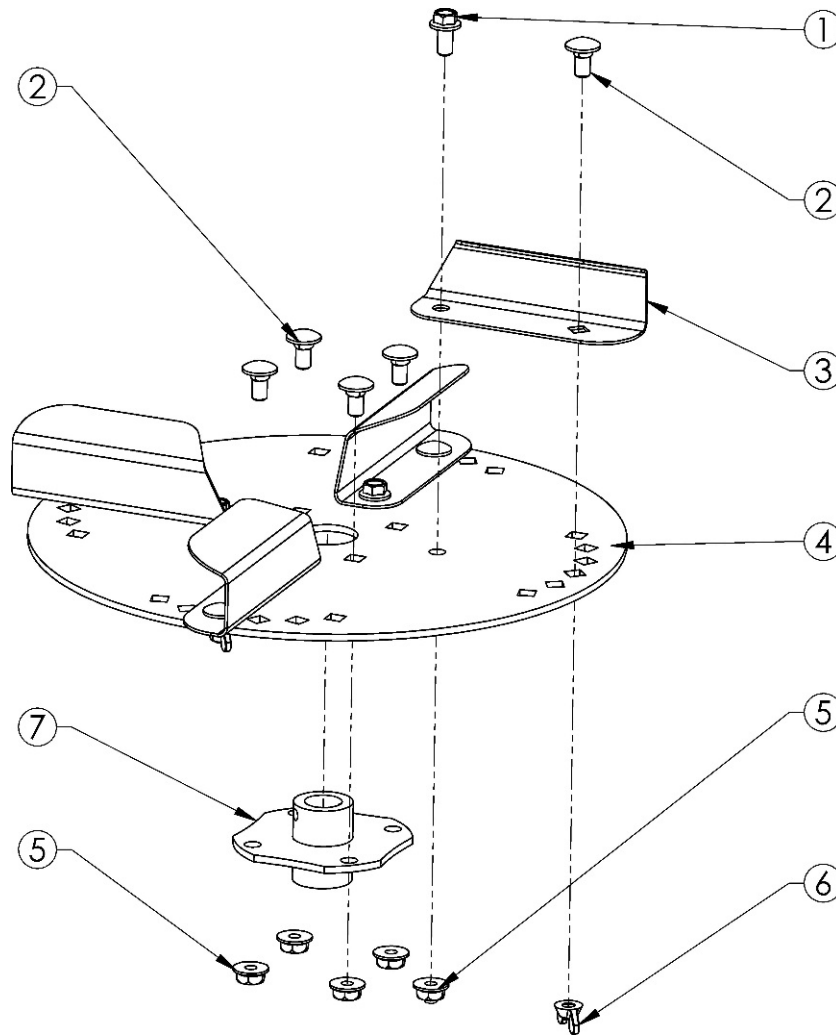
# WIRING DIAGRAM

## 22413 SPREADER HARNESS



# PARTS DIAGRAMS

## SPINNER DISC ASSEMBLY

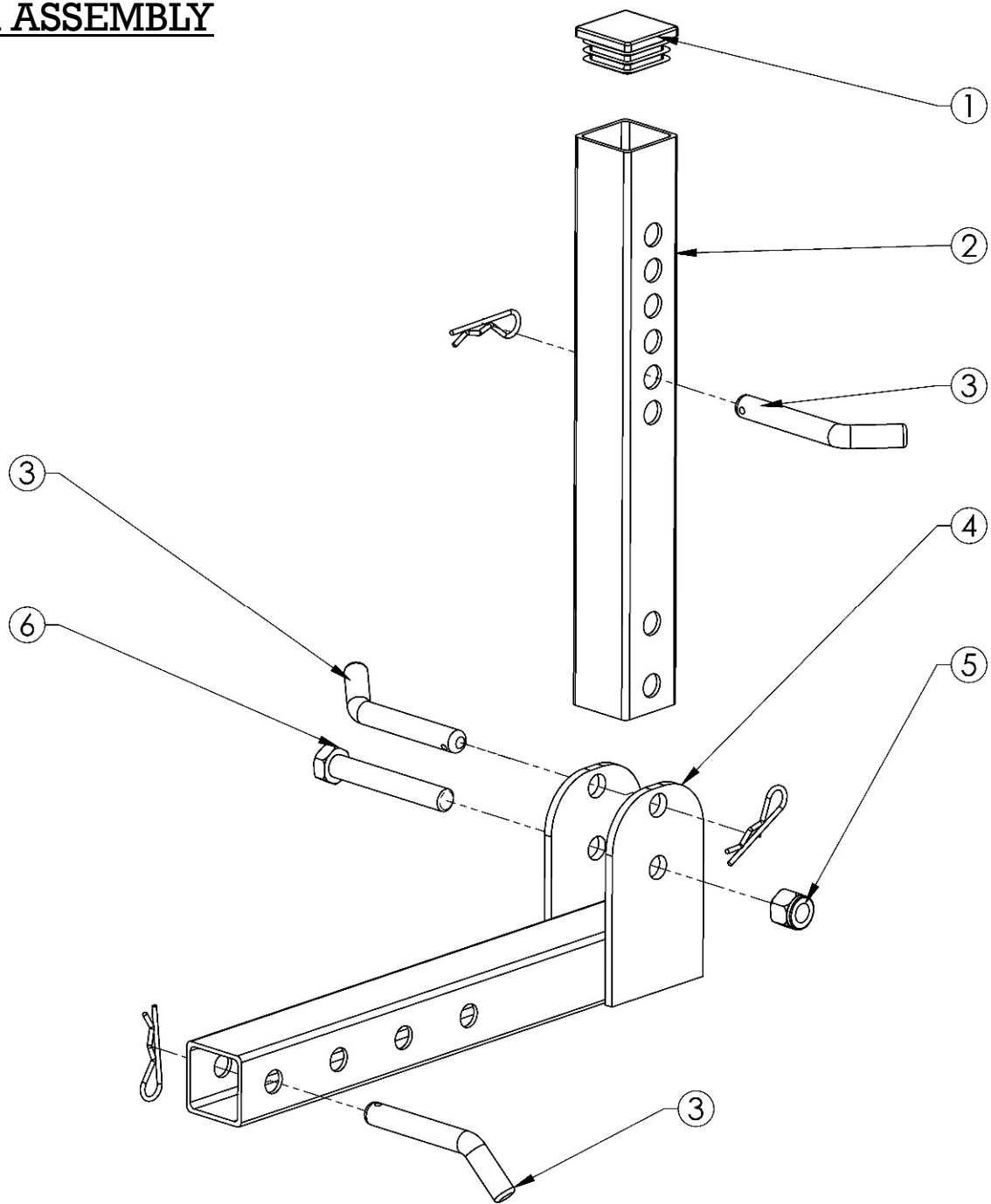


Note: Some parts not shown for clarity.

ITEM #	DESCRIPTION	PART #
1	Bolt - Serr Flange, 1/4-20 X 1/2 GR5	22615
2	Bolt - Carriage 1/4-20 X 1/2	22616
3	Plate - Fin, Spreader; Galv	22202GV
4	Plate - Spinner, Spreader; Galv	22201GV
5	Nut - Serr Flange, 1/4-20 Grade 5	22617
6	Nut - Wing 1/4-20	22614
7	Weldment - Spinner Disc Mount; Galv	22223GV

# PARTS DIAGRAMS

## RECEIVER ASSEMBLY



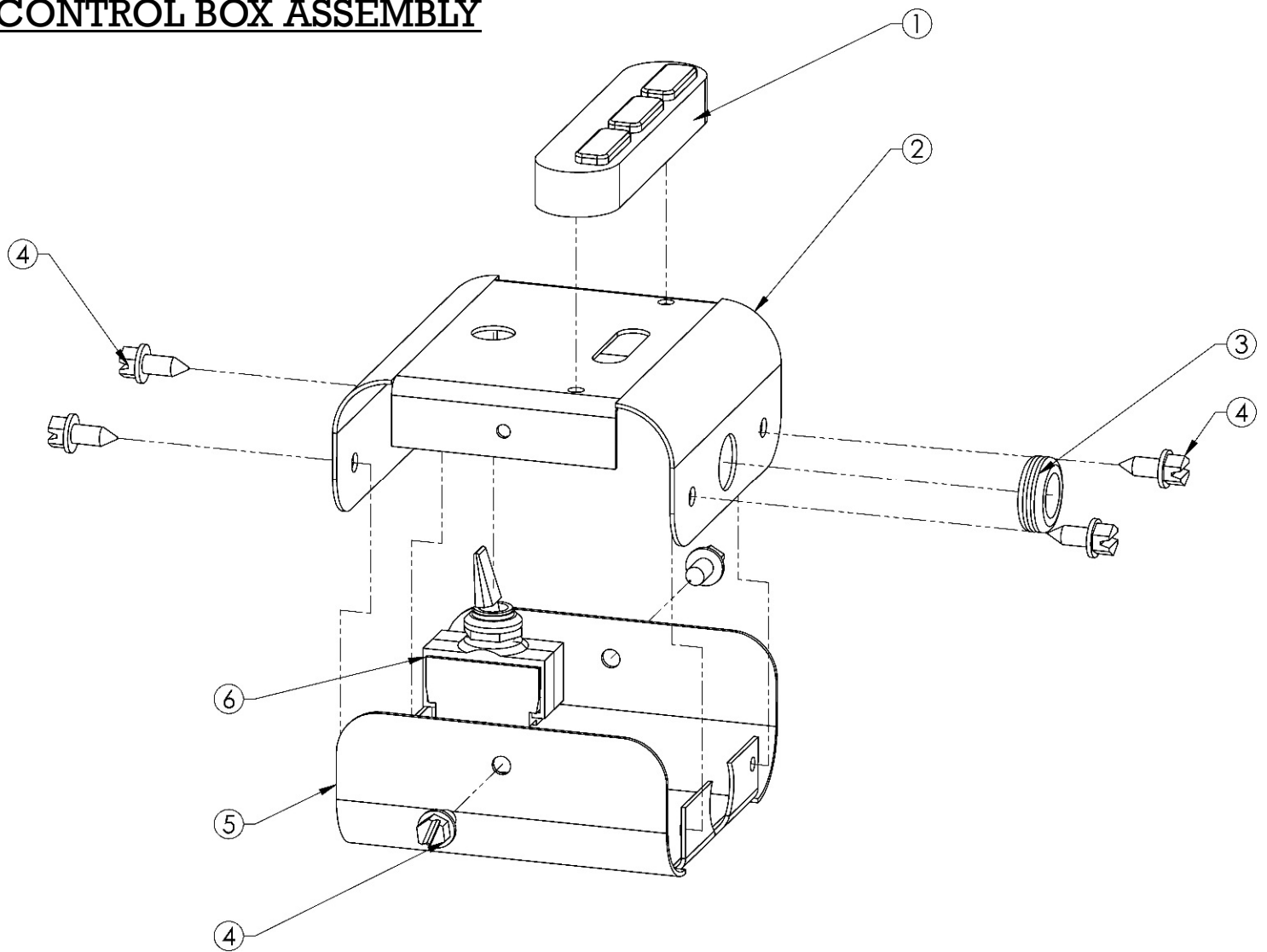
Note: Some parts not shown for clarity.

ITEM #	DESCRIPTION	PART #
1	Tubing Plug - 2" X 2"	50062009
2	Tube - Frame, H/A; Spreader	22205*
3	Pin - Bent w/Hair Pin, 5/8 X 3 ZP	NB702
4	Weldment - Receiver; Spreader	22210*
5	Nut - Nyloc 5/8-11 ZY Grade 2	NB561
6	Bolt - 5/8-11 X 4 GR5 ZY	NB581



# PARTS DIAGRAMS

## CONTROL BOX ASSEMBLY

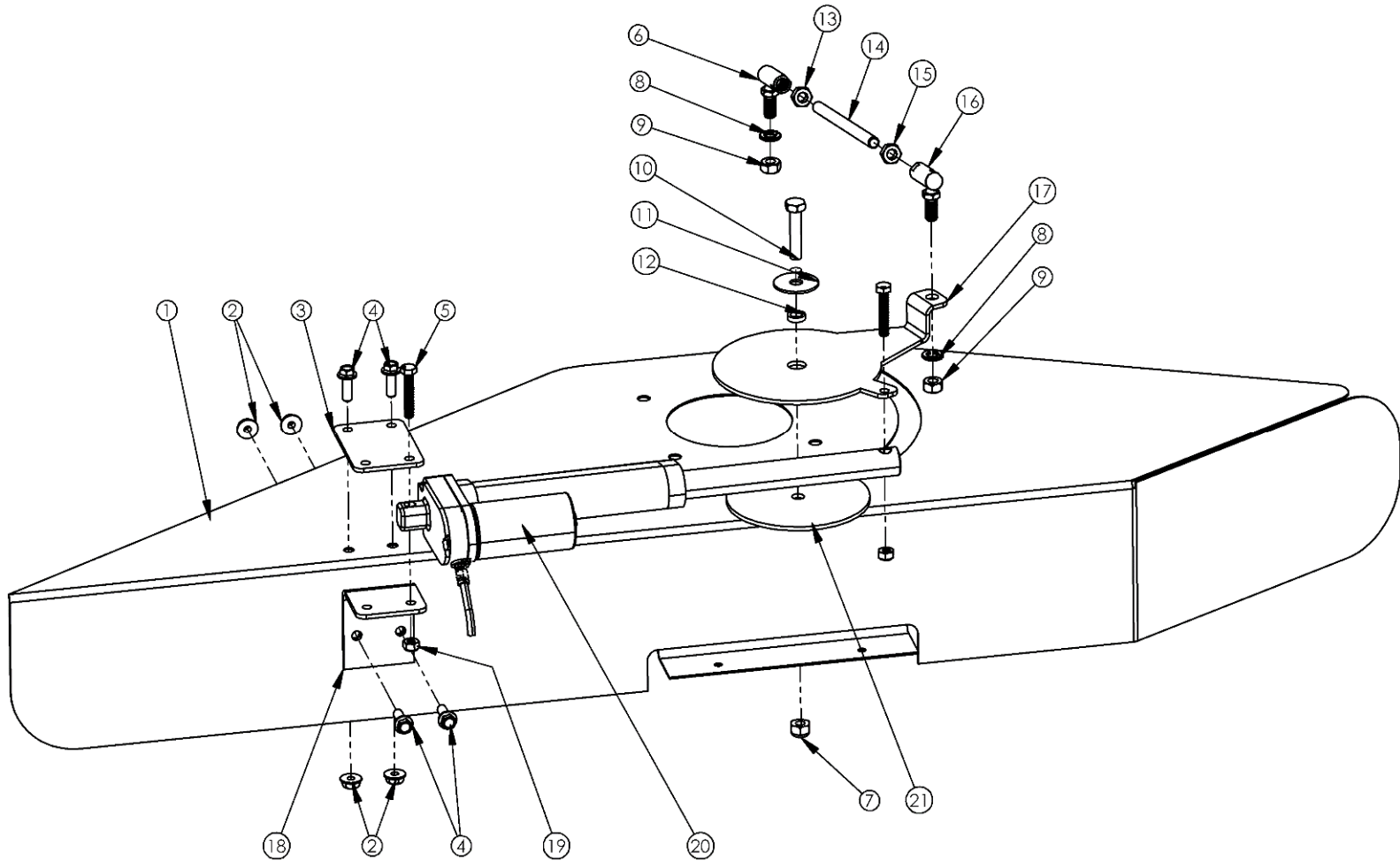


**Note:** Some parts not shown for clarity.

ITEM #	DESCRIPTION	PART #
1	Control - Actuator; Switch	22235
2	Plate - Console, Top; Spreader	22219*
3	Grommet - Wiring; 1/2" ID X .047 Panel	22228
4	Screw - 12 X 1/2 Hex Self Tap	024206
5	Plate - Console, Bottom; Spreader	22220*
6	Switch - Toggle On/Off SPST, 2 Term	19912

# PARTS DIAGRAMS

## ACTUATOR ASSEMBLY

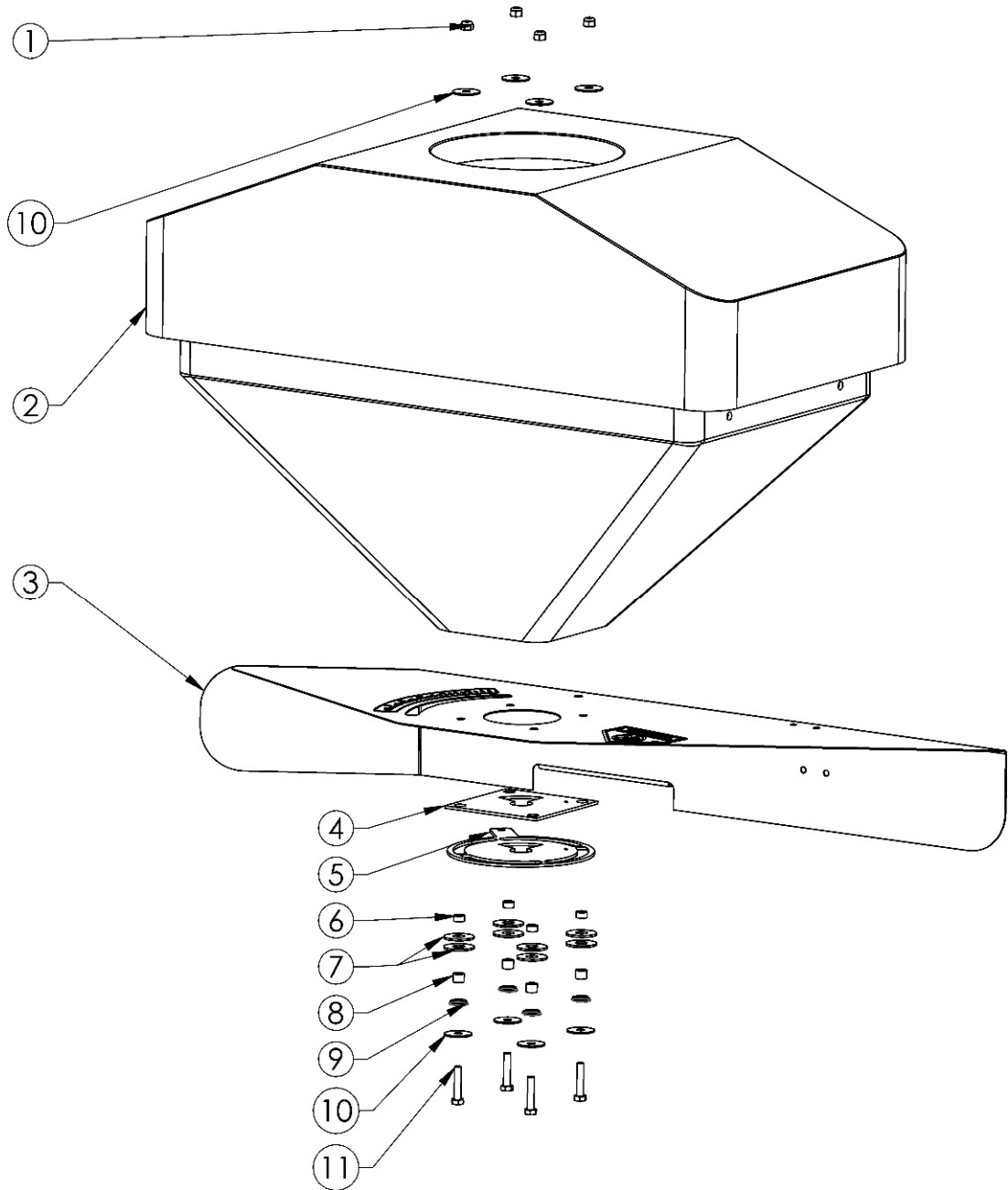


**Note:** Some parts not shown for clarity.

ITEM NO.	PART NUMBE	DESCRIPTION	QTY.	ITEM NO.	PART NUMBE	DESCRIPTION	QTY.
1	22211	Plate - Spreader ;Deflector	1	12	23320	Bushing - .33 ID x .493 OD x .135	1
2	22617	1/4-20 Flange Nut SS	4	13	NB265	NUT - JAM, 5/16"-24 ZY GRD 2	1
3	22236	Plate - Actuator ; Support	1	14	22233	LINKAGE - 5/16-24 LHT & RHT, 5"	1
4	22612	1/4-20 X 3/4 Serrated Flange SS	4	15	NB190	NUT - JAM, 5/16"-24 ZY GRD 2	1
5	22238	Bolt - M6-1.00 X 35 Grade 8	2	16	NB263	BALL JOINT - 5/16-24, RIGHT, ZP	1
6	NB264	BALL JOINT - 5/16-24, LEFT, ZP	1	17	22234	Plate - Actuator Arm	1
7	22609	5/16-18 NYLOC NUT SS	1	18	22227	Plate - Actuator Mount	1
8	NB159	Washer - Split Lock 5/16 ZY	2	19	22239	Nut - M6-1.00 ; Nylock	2
9	NB215	NUT - HEX 5/16-24 GR2 ZY	2	20	22221	Actuator - 4" Stroke	1
10	22608	5/16-18 X 1.50 BOLT SS	1	21	22240	Plate - Support ; Actuator Arm	1
11	22606	WASHER - 5/16 X 1 1/4" OD SS	1				

# PARTS DIAGRAMS

## HOPPER ASSEMBLY

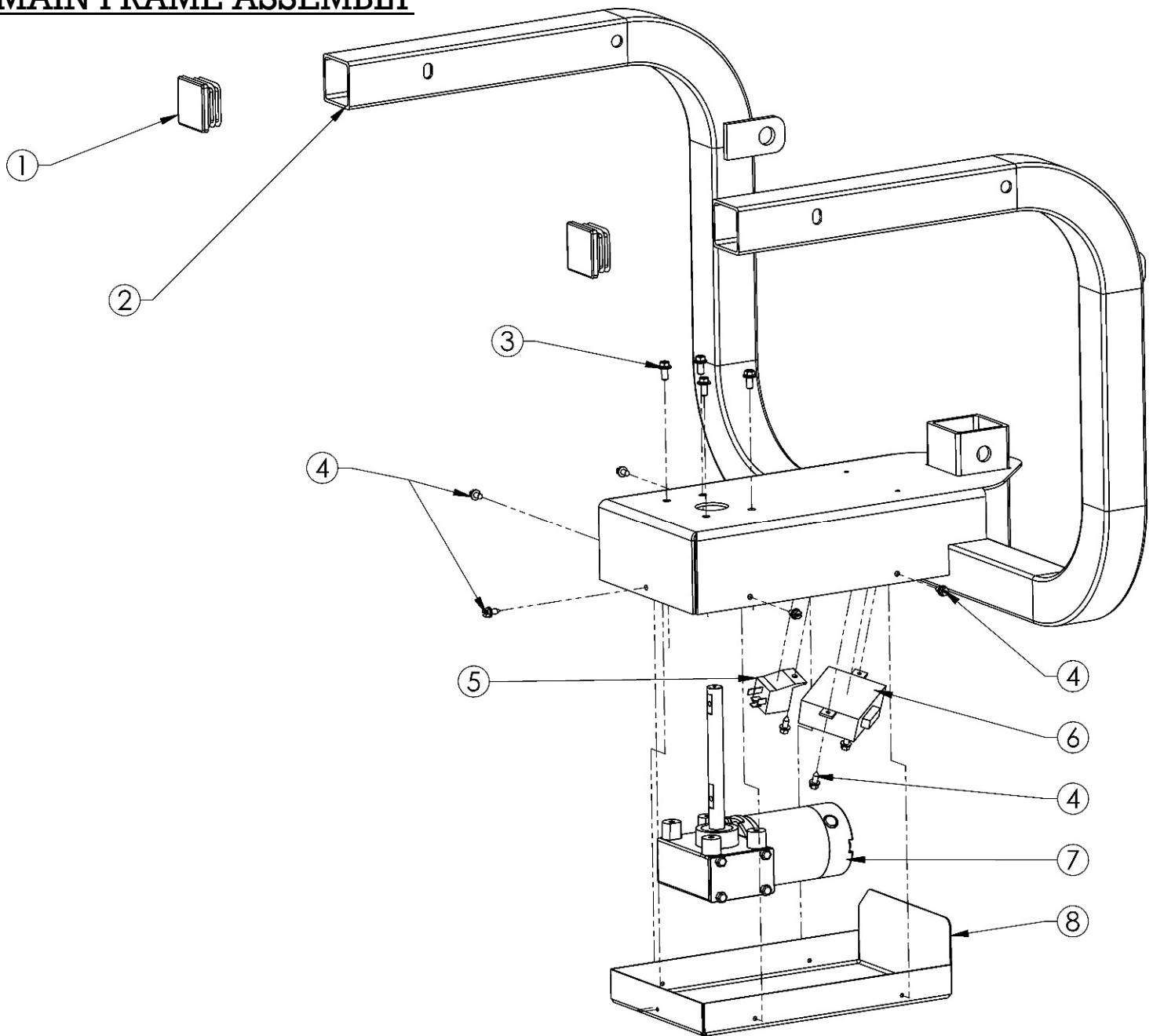


ITEM #	DESCRIPTION	PART #
1	Nut - Nyloc 5/16-18	22609
2	Tank - Truck Spreader	10975
3	Weldment - Spreader Plate Deflector Galv	22211GV
4	Plate - Hopper, Base; Galv	22212GV
5	Plate - Hopper, Gate; Galv	22213GV
6	Bushing - Latch Pin	7839Z
7	Washer - USS Flat, 1/2	22605
8	Bushing - Lift Bar	7825Z
9	Spring - Gate, Spreader	22610
10	Washer - Fender, 5/16 X 1 1/4 OD GR2	22606
11	Bolt - 5/16-18 X 1 1/2 HCC GR5	22608

Note: Some parts not shown for clarity.

# PARTS DIAGRAMS

## MAIN FRAME ASSEMBLY



Note: Some parts not shown for clarity.

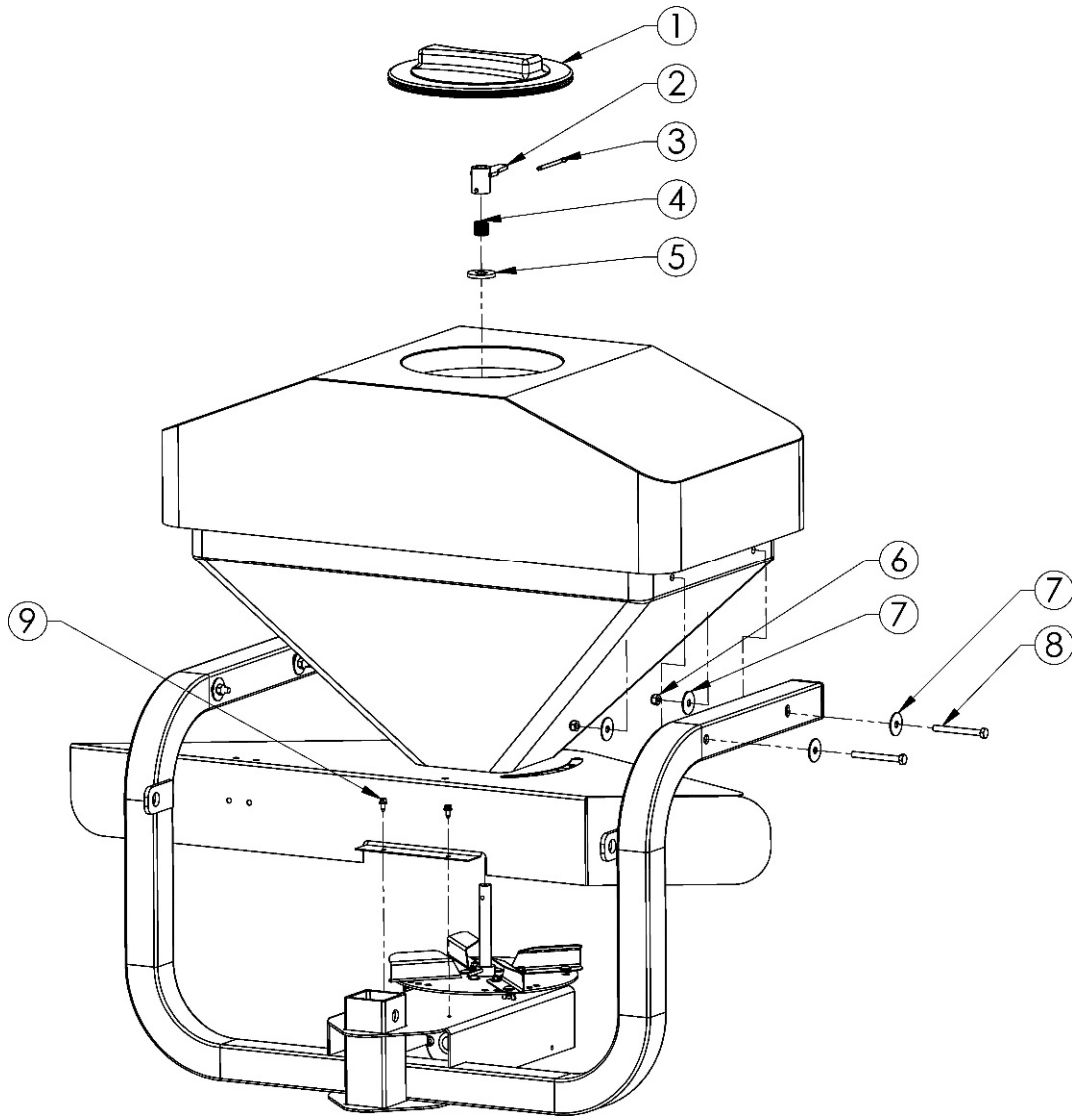
ITEM #	DESCRIPTION	PART #
1	Tubing Plug - 2" X 2"	50062009
2	Weldment - Main Frame; Spreader	22207*
3	Bolt - Serr Flange, 1/4-20 X 1/2 GR5	22615
4	Screw - 12 X 1/2 Hex Self Tap	024206
5	Electrical - Relay; 40A/50A	22231
6	Control - Actuator	22235
7	Motor - 12V DC, 781 RPM, 5/8"	22215
8	Plate - Motor Cover	22226*

When ordering replacement parts

\* = USE PAINT CODE: TK=BLACK

# PARTS DIAGRAMS

## AGITATOR & HOPPER MOUNTING



ITEM #	DESCRIPTION	PART #
1	Lid - Tank, Truck Spreader	10176
2	Weldment - Agitator; Galv	22230GV
3	Pin - Cotter, 3/16 X 2.25; ZP	19036
4	Spring - Compression; .625" ID	22260
5	Washer - Plastic, 3/16" THK, 5/8" ID	22225
6	Nut - Nyloc 5/16-18	22609
7	Washer - Fender, 5/16 X 1 1/4 OD GR2	22606
8	Bolt - 5/16-18 X 3 GR2	22618
9	Screw - 12 X 1/2 Hex Self Tap	024206

Note: Some parts not shown for clarity.

# CALCULATING MATERIAL FLOW

## GENERAL RECOMMENDATIONS

- The chart in **figure 30.2** only represents general guidelines for certain material flow rates. Many factors affect how a material will spread including, but not limited to, moisture content, ambient temperature, humidity, weather conditions, brand of medium and many more.
- For the most accurate distribution of material, always calculate the flow rates of the material being spread.

## Calculating Material Flow

- Fill the Hopper with a known weight of the desired material. (ex. 20 lbs of seed)
- Place a tarp under the spreader base to catch the dropped material for re-use.
- Open the control gate to any desired opening and time (seconds) how long it takes for all the material to leave the hopper. This will give you how many pounds/second at that particular opening.
- Next it is recommended to refill the same amount of material into the Spreader. Find an area to spread this material where you can see the spread width. Once you have determined your desired speed, and material flow rate you can calculate the pounds per acre for accurate coverage. Use the work sheet and notes on **pages 31-32** to log and record flow rates for future use.

VOLUME CONVERSION	
BUSHELL	CUBIC FEET
0.43	0.53
0.64	0.80
0.86	1.07
1.29	1.60
1.72	2.14
2.15	2.67
2.58	3.21
3.01	3.74
3.44	4.28
3.87	4.81
4.30	5.35
4.73	5.88
4.94	6.15
5.16	6.42
5.59	6.95

**FIGURE 30.1**

GENERAL MATERIAL FLOW RATES				
MATERIAL	SPEED (MPH)	WIDTH (FT)	POUNDS / ACRE @	
			FULLY OPEN GATE	HALF-WAY OPEN GATE
SAND	3	35	220	109
	5		132	65
ROCK SALT (1/4" min)	3	35	87	42
	5		29	15
RED CLOVER	3	25	178	89
	5		106	53
FESCUE	3	15	108	54
	5		62	33
RYE	3	15	107	54
	5		65	32

**FIGURE 30.2**



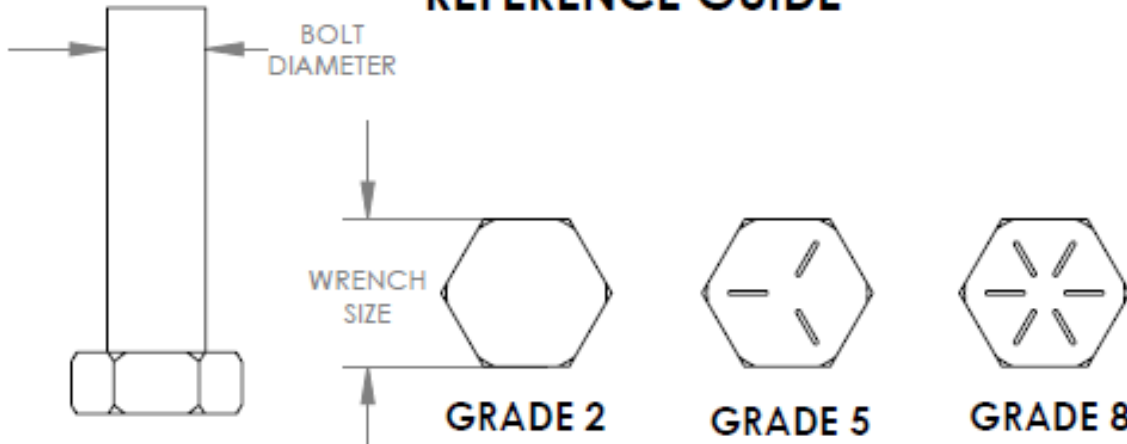








## TORQUE SPECIFICATIONS REFERENCE GUIDE



Bolt Diameter (INCH)	Wrench Size	SAE GRADE 2		SAE GRADE 5		SAE GRADE 8	
		lb-ft	(Nm)	lb-ft	(Nm)	lb-ft	(Nm)
1/4	7/16	5.5	(7)	9	(12)	12.5	(17)
5/16	1/2	11	(15)	18	(24)	26	(35)
3/8	9/16	20	(27)	33	(45)	46	(62)
7/16	5/8	32	(43)	52	(70)	75	(102)
1/2	3/4	50	(68)	80	(108)	115	(156)
9/16	7/8	70	(95)	115	(156)	160	(217)
5/8	15/16	100	(136)	160	(217)	225	(305)
3/4	1-1/8	175	(237)	280	(380)	400	(542)
7/8	1-5/16	175	(237)	450	(610)	500	(678)
1	1-1/2	270	(366)	540	(732)	750	(1017)
1-1/8	1-11/16	300	(407)	675	(915)	1075	(1457)
1-1/4	1-7/8	425	(576)	950	(1288)	1500	(2034)

Torque values are for reference. 10% variance is allowable. Use these values unless specific torque values are given for a specific application.

Fasteners should be replaced with the same grade. Make sure fasteners threads are clean and that you properly start thread engagement. This will prevent them from failing when tightening.

Tighten toothed or serrated-type lock nuts to the full torque value.

[www.swisherinc.com](http://www.swisherinc.com)

# OWNER'S MANUAL

**MODEL NO.  
22340**



## IMPORTANT

Read and follow all  
Safety Precautions  
and Instructions  
before operating this  
equipment.

# Commercial Pro Truck Spreader

Each Spreader has its own model number. The model number for the Spreader will be found on the lower section of the main frame facing towards the vehicle. All Spreader parts listed herein may be ordered directly from Swisher or your nearest Swisher dealer.

WHEN ORDERING PARTS, PLEASE HAVE THE  
FOLLOWING INFORMATION AVAILABLE:

- \* PRODUCT – COMMERCIAL PRO TRUCK SPREADER
- \* SERIAL NUMBER - \_\_\_\_\_
- \* MODEL NUMBER - \_\_\_\_\_
- \* PART NUMBER
- \* PART DESCRIPTION

TELEPHONE - 1-800-222-8183  
FAX - 1-660-747-8650

**SWISHER ACQUISITION INC.**  
1602 CORPORATE DRIVE  
WARRENSBURG, MO 64093  
[www.swisherinc.com](http://www.swisherinc.com)

# **SWISHER**®

**CHANGING YOUR LANDSCAPE SINCE 1945**