

Verify that your ground system is working (cont.)

You are now ready to test the energizer ground system. Connect one lead of the digital volt meter to a 12 inch metal stake driven into the ground 3 feet away from the last fence energizer ground rod. Connect the second lead to the ground rod furthest from the energizer. The voltage reading should ideally be zero or no more than 200V.

If the digital volt meter reading is under 200V, your ground system is adequate and you will get a near maximum performance from your electric fence energizer.

If the reading is above 200V, then your ground system needs improvement. You must: a. Add more ground rods connected in series, 3 feet apart and/or b. Move your ground system to moist soil until the voltage is below 200V.

Check your ground system condition with a volt meter once during the driest period and once during the wet season each year to insure adequate grounding of your electric fence.

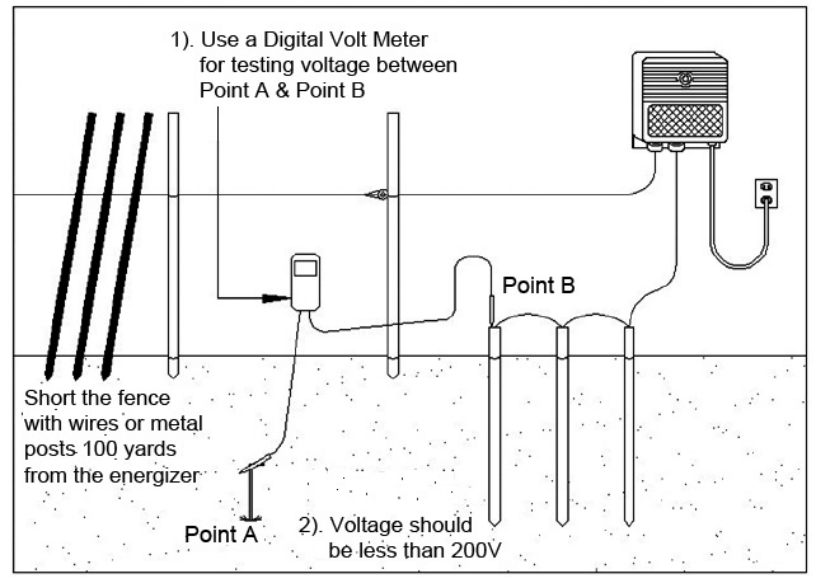

Diagram 2 - Testing Ground System

Installation STEP 5: Connect the fence hot (red knob)terminal

Note: Ensure the energizer is OFF before making this connection or you will be shocked.

- 1. Refer to the red fence terminal knob on the front/bottom of the energizer. The red knob is under small lightning bolt on the front label.
2. Unscrew the fence terminal knob without fully removing it. Make a "J" shape in a bare end of hook-up wire, wrap this bare end of wire around the fence terminal bolt "between" the two washers, and "hand tighten" the red knob. Do not use pliers or other tool to over tighten the knob or you may damage the knob. 10 to 14 gauge insulated lead-out wire (rated at 20,000V) is commonly used for this.
3. Properly connect the other end of the wire to your fence. A split bolt line tap is a common means of connection. Refer to Diagram 2 (WIRE SPLICING AND CONNECTIONS) for other connection means.

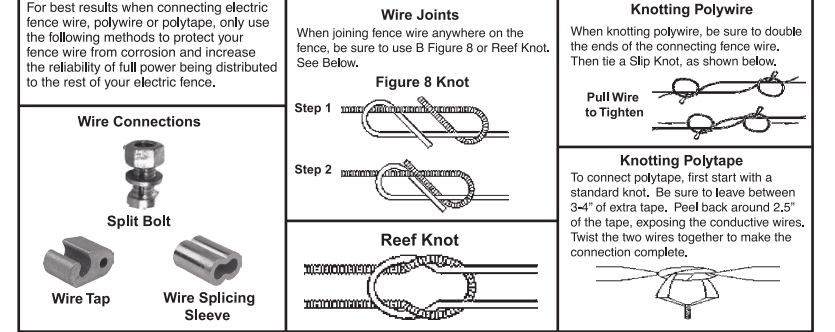
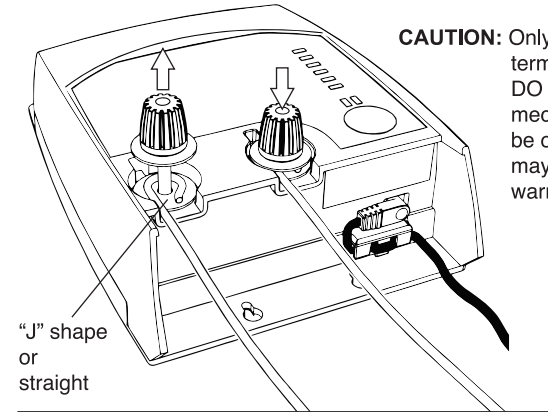

Diagram 3 - Wire Splicing and Connections

Installation STEP 6: Turn on and Test

Turn ON

With the desired power cable (110V Adapter or 12V battery) connected to your energizer, and the energizer off, press and release the energizer pushbutton one time. You will be in full-power mode and the full-power LED will be lit.

Immediately after power-on, for an approximate duration of 5 seconds, the front panel LEDs (lights) will be flashing in a sequence as it's performing a self-check. After the self-check has completed the energizer will produce the high voltage pulse about every 1.5 seconds.

Press and release the energizer pushbutton again and you will switch from full power mode to half-power mode and the half-power LED will be lit.

Press and release the energizer pushbutton again and the energizer will switch off.

Test (fence condition)

Turn the energizer back on. You want to look for one of two conditions on the front panel LEDs (lights) to know the condition of your fence. Either green LEDs or the single red LED will flash with each fence pulse.

Green LEDs - From 1 to 5 green LEDs will light up with each high voltage pulse of the energizer. Your fence is in good condition if you even get 1 green LED. The more LEDs that light, the higher the voltage at the energizer terminals, and the better condition your electric fence.

See the 'Output Voltage / Battery Voltage Chart' right for voltages

Note: Your energizer may light more green LEDs in full-power mode than it will in half-power mode.

Red LED - If only the red LED lights, with each fence pulse, then the voltage at the energizer fence terminals is less than 2000V.

You should check all electric fence wire connections and look for fence-line shorts. An easy way to locate bad fence connections is to walk the fence and "listen" for arcs. You should not hear this snapping sound at the fence connections. The sound is similar to a static electricity sound when touching a door knob after walking on carpet. If you do hear the arc sound, then the connection is not sufficient.

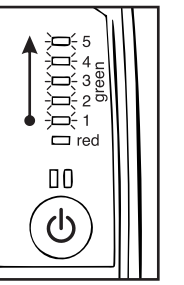
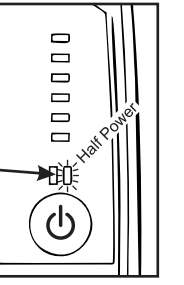
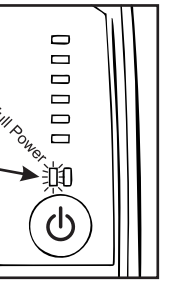

Test (battery voltage)

Note: If you are plugged into 110V mains, via the AC adapter, then the battery test has no meaning to you. Battery voltage test only has a meaning when connected to the external 12V battery, via the battery clamp wire assembly.

- When the unit is on and pulsing in normal operation, in either the full-power or half- power mode, then press and "HOLD" the pushbutton to display battery voltage on the front LEDS.
After about 2 seconds the energizer stops pulsing and displays either 1-5 green LEDs, or 1 red LED. These LEDs are continuously on and remain on until you release the pushbutton. The more green LEDs that are displayed, the more energy that is remaining in your battery.
If the one red LED remains on, then your battery is depleted and you need to swap it out and recharge it now.
When you are done testing your battery voltage then release the pushbutton and your energizer returns to the full or half-power mode it was originally in, and resumes normal pulsing.

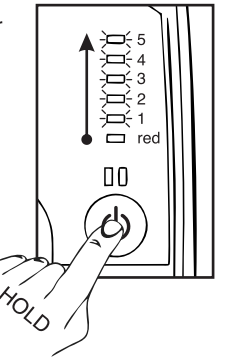

Table with 2 columns: Fence Indicator Approx Output Voltage (kV) and Battery Indicator Approx Battery Charge (%). Rows show voltage ranges from 8000 to <2000 and corresponding LED counts (green or red).

Battery Test

This energizer gives you many options for what rechargeable battery amp hour (Ah) capacity to use. Refer to the below chart, as an example, when selecting a lead acid or marine type rechargeable battery to know how many days this battery will run your energizer until you have to replace it with another battery. These are approximate and are only valid for healthy batteries. The older the battery, and the more times it's been charged and discharged, the less capacity (and battery life) it will have.

Table: Days of Life with a given battery capacity. Columns: AC/DC Model, Full Power, Half Power for 100Ah, 170Ah, and 280Ah capacities.

Note: If you want to extend the battery life, then swap batteries when only one green battery LED is lit (during the battery test mode). This will prevent you from over-discharging the battery and help extend its life. Also, after replacing batteries immediately charge the discharged battery to extend its life and sustain its rated capacity.

Battery too low, the energizer will not produce a high voltage pulse

- If the battery voltage is too low, less than 11V, then the energizer will not produce a high voltage pulse. By stopping at 11V this will help protect your battery life. If less than 11V, even though a very small amount of energy is remaining in your battery, it has consumed it's full rated amp hour capacity.
If the battery is below 11V, then the green mode LED (either full or half-power) flashes and the red LED will flash too. These two LEDs will alternate flashing at a fast pace to identify the battery is less than 11V.

WARNING! Do not attempt to recharge a non-rechargeable battery. When charging a battery, ensure there is sufficient ventilation so gasses can safely disperse.

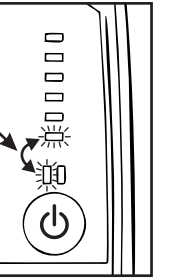

PRODUCT GUARANTEE AND WARRANTY

30 DAY SATISFACTION GUARANTEE We guarantee your complete satisfaction with this fence energizer. If you are not satisfied with this product, you may return the energizer to the original place of purchase within 30 days of purchase for a full refund. Proof of purchase is required for a refund.

LIMITED WARRANTY This product is warranted to the original purchaser only, with proof of purchase, for a period of thirty-six (36) months from the date of purchase, when installed and used in accordance with enclosed installation instructions. The one exception is the AC power adapter which is under warranty for 12 months. Proof of purchase is required for warranty consideration. This warranty covers defects in materials and workmanship to the fence energizer. The warranty also covers damage to the energizer caused by lightning.

TERMS THAT APPLY TO BOTH THE GUARANTEE AND WARRANTY Improper installation, misuse, neglect, tampering, or any other reason not related to material or workmanship are NOT covered under the 30-Day Guarantee or the Limited Warranty. No warranty other than the above is expressed or implied. Implied warranties of merchantability and fitness for a particular application are hereby disclaimed unless the law specifically precludes this disclaimer. The manufacturer and seller shall have no liability for damages, incidental or consequential, resulting from or caused by any failure, malfunction or defect of any product.

Our sole obligation shall be limited to repair or replacement, at its option, of the defective fence energizer or part.

TO MAKE A WARRANTY CLAIM

- 1. First disconnect energizer from fence and confirm that voltage output at the energizer terminals is not normal.
2. Before returning product under warranty, you must call us (refer to front label for phone number) to obtain a Return Goods Authorization number and a shipping address for the service center that will process the return. The RGA number must accompany the returned product.
3. Attach a note showing your name, phone number, return address and brief description of the problem.
4. Pack product carefully in oversized carton with crushed newspaper for cushioning.
5. Your product should be shipped prepaid and insured against shipping loss or damage.

AC/DC Dual Power Electric Fence Energizer

Installation, Operating and Warranty Instructions

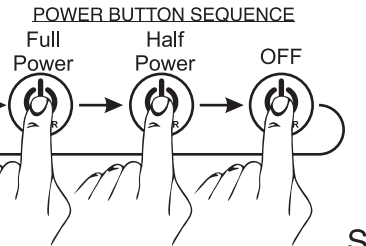
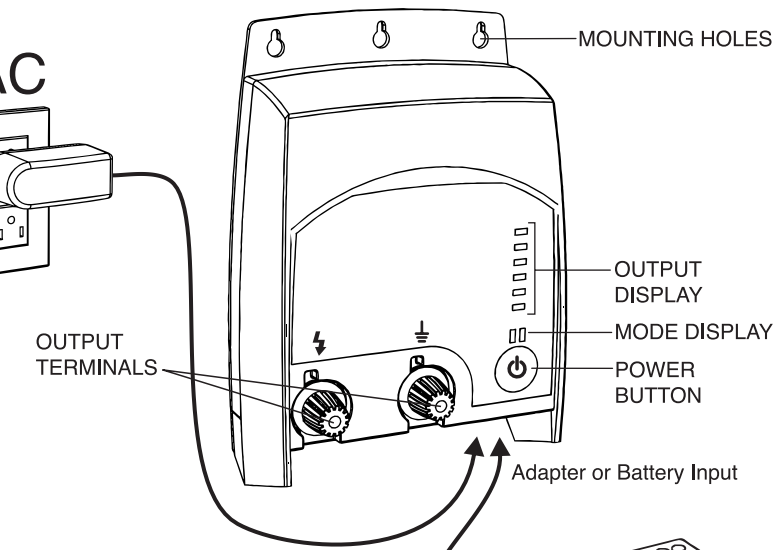

WARNING: READ ALL INSTRUCTIONS BEFORE INSTALLATION.
 Only use electric fence controller for the purpose indicated in this manual.
CAUTION: To reduce the risk of electric shock do not remove cover. Refer to service personnel. Always turn off energizer before handling.
WARNING: Do not connect simultaneously to a fence and any other device such as a cattle trainer or a poultry trainer. Otherwise, lightning striking your fence will be conducted to all other devices.
WARNING: NEVER put more than one energizer on a fence. Doing so can be hazardous, and may also damage the energizer.
WARNING: In areas prone to brushfires turn off the fence controller on very dry days.
WARNING: During lightning storms do not disconnect wires or approach the electric fence.
WARNING: NEVER electrify barbed wire or similar fence types were humans or animals can become entangled in the fence or caught against the fence.
WARNING: Do not operate electric fence controllers near any combustible materials including gasoline, cleaning fluids and kerosene.
CAUTION: RISK OF ELECTRIC SHOCK. Do not install where small children, the elderly or unhealthy persons may come in contact with the live portions of electric fencing. Use electric fence warning signs where humans may come in contact with the fence.
WARNING: Follow all national, state and local codes and regulations that apply to installation of electric fence in your area.
REFER TO AUTHORIZED REPAIR CENTER FOR SERVICE. Never alter the design of the energizer. Doing so is hazardous and will void the warranty.

WARNING: DO NOT run fence wire above ground near high voltage power lines. If too close, the electric fence may pick up dangerous levels of power from high voltage lines. Do not cross under a high voltage line with electric fence.
WARNING: Electric fences are very effective psychological barriers when properly installed and when animals are trained to the fence. Electric fences are NOT complete physical barriers. Erratic animal behavior cannot be predicted and occasional fence penetration can occur. Therefore, Power Wizard assumes no liability for animal containment, injury or the consequences for the misuse of the equipment.

Note: The fence hot terminal is either indicated by a red knob or a lightning bolt symbol (⚡) and the ground is indicated by a black knob or an arrow symbol (↓).

SPECIFICATIONS, FEATURES, AND APPLICATIONS

- 110V AC with AC power adapter.
- External 12VDC rechargeable battery (NOT INCLUDED)
- Full-Power and Half-Power modes – User selectable full or half power mode.
- Fence Voltage Indicators – LED indicators let you know the terminal voltage, and if your fence has too many shorts.
- Battery Voltage Indicators – LED indicators let you know when to swap you current battery with a fully charged battery.
- 1J or 3J output depending on the model (not stored energy, but output onto the fence).
- Easy mounting with 3 optional mounting holes on the top of the unit and 2 at bottom.

- Take care of the 5 following details to prevent many hours of extra work.**
1. Grounding - Carefully install a complete ground system. Most electric fence failures are caused by an improper ground system (see Diagram 1).
 2. Connections – Carefully connect lead out wire, ground wire and fence line splices. This is the second most common cause of electric fence failure. Use clamps, split bolts and taps for securing wire connections. Make sure all connection surfaces are of bare, shiny metal (see Diagram 2, Wire Splice and Connections).
 3. Use adequately insulated hook-up wire (rated for at least 20,000V) where the hot wire must travel underground. Never use standard household insulated wire, which is typically rated for only 600 volts or less.
 4. Maintain at least 75 feet from buried and above ground utility company ground rods, water pipes, metal siding, telephone wire and stock watering tanks.
 5. Finally, it is very important that an animal's first experience with an electric fence shock is one of respect. Some animals require more than one shock experience for lasting respect of the fence line. Always train the animal to the fence prior to unsupervised entry into pastures by insuring that the animal's first approach to the fence is slow, without stress and that an effective repelling shock is experienced.

- Tools Needed**
1. Hammer or Screwdriver – for mounting energizer
 2. Wire cutters – to cut and strip insulation
 3. Post driver – to install ground rods and posts
 4. Digital volt meter – for electric fence testing and troubleshooting.

- Accessories Needed**
1. 1 to 3 galvanized ground rods – minimum 4-6 feet long by 1/2" (minimum) diameter
 2. 1-3 ground rod clamps
 3. Insulated underground hook-up wire – 25 feet (20,000V rating)
 4. Line clamps
 5. Highly Recommended: One lightning choke and one lightning diverter or a combination choke and diverter. Lightning is the number one cause of failure in electric fence energizers. Use these to extend the life of your energizer.
 6. Nails or screws for mounting

Installation Instructions (Steps 1-5)
Installation STEP 1: Mount The Energizer
 Using the energizer's 3 upper mounting keyholes and the 2 lower mounting keyholes, drive either screws or nails into a stable wooden surface to mount the energizer. Not all energizer mounting holes are needed, but use as many as possible to ensure the energizer is stable and will not move if the fence or power wires are pulled.

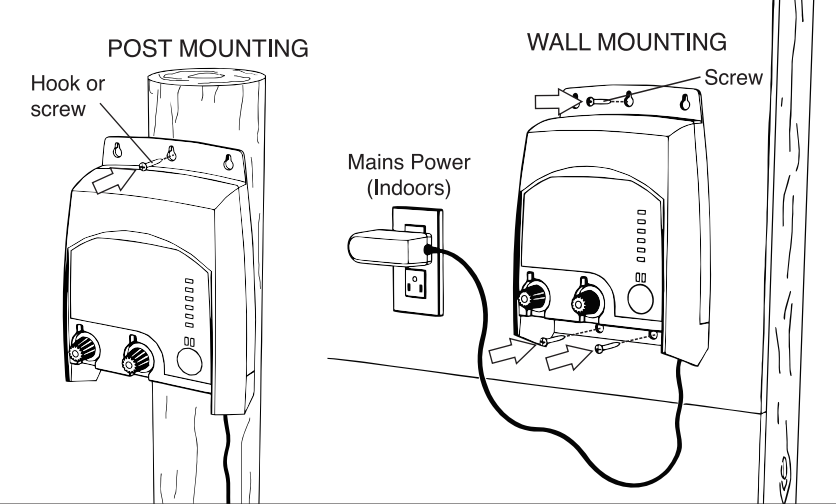

Installation STEP 2: Connect Power and Test Energizer
Connect Power
 There are two power options for your dual power AC/DC energizer: 110V mains or 12V battery.

- **110VAC mains**
 If you have access to a 110V mains power socket, then use your AC adapter to power your energizer. Recommended to use only indoors, in dry locations.
- **12VDC battery**
 If you don't have access to 110V mains then use the battery clamp wire assembly to connect to a 12V rechargeable battery to power your energizer. This is suitable for outdoor or indoor use.

Connect Power (cont.)

- Connect the desired power source to the energizer at the base of the unit. Both power sources use the same socket. Tuck the power cable up into the cable strain relief to avoid accidental disconnection.

Test Energizer

- With the energizer off, and disconnected from the fence, press and release the energizer pushbutton.
- The energizer will go through a power-on self test for about 5 seconds as represented by the LEDs sequence.
- After power-on self test completes, the unit will start putting a high voltage pulse onto the energizer terminals.
- The vertical row of green LEDs will light. The more that light, the higher the energizer pulse voltage and the better condition you fence is in.

Full or Half-Power selection

Start with the energizer OFF.

- Press and release the push button one time. You should now be in full power mode and the full power green led will be on continuously to identify full-power mode.
- Press and release the push button another time (while in full-power mode). You should now be in half-power mode and the half-power green LED will be on continuously to identify half-power mode.
- While in half-power mode press and release the push button another time and the unit will turn off.
- Thus, the unit cycles from (off) to (full power) to (half-power) and to (off) as you press and release the push button.

WARNING
 Use only 12V rechargeable lead acid battery if powered by an external battery

Test Energizer (cont.)
Power Button Sequence

Note:
 Full-power is the normal operating mode. Half-power mode is mainly used to train young animals to the fence, train new animals to the fence, or if you want to extend the number of days before swapping batteries, or if you are not concerned about predator animals.

Installation STEP 3: Connect energizer ground terminal (black) to ground rod/s

The "ground system" consists of 1 or more highly conductive ground rods driven into the soil and then connected by wire to the ground terminal of your fence energizer. The ground system allows current to flow through the soil to complete the circuit needed for delivering an effective shock.

1. Locate an area of soil for placing ground rods that contains good conductive earth (not sandy or rocky). Soil that is moist throughout the year is best. The ground system should be located within 75 feet of your fence energizer and at least 25 feet from buildings.
2. Locate ground system a minimum of 75 feet away from: Utility company (electric, gas, water) ground system, underground water pipe, metal water tanks, and metal siding on building (minimum 25 ft. away).
3. Drive one 4-6 foot (6 foot preferred) by 1/2" (minimum) galvanized ground rod into the ground. Leave 6 inches above the ground for securing ground clamps. Mark the area as a hazard.
4. If more than 1 ground rod is used connect the ground rods, in a series, 10 feet apart, with one piece of continuous 10 to 14 gauge galvanized wire. Use clamps to secure the wire to the ground rod. The ground hook-up wire should be equal to or larger than the diameter of the fence line wire.

IMPORTANT
 Avoid pounding your ground rods into SANDY, DRY and ROCKY soil.

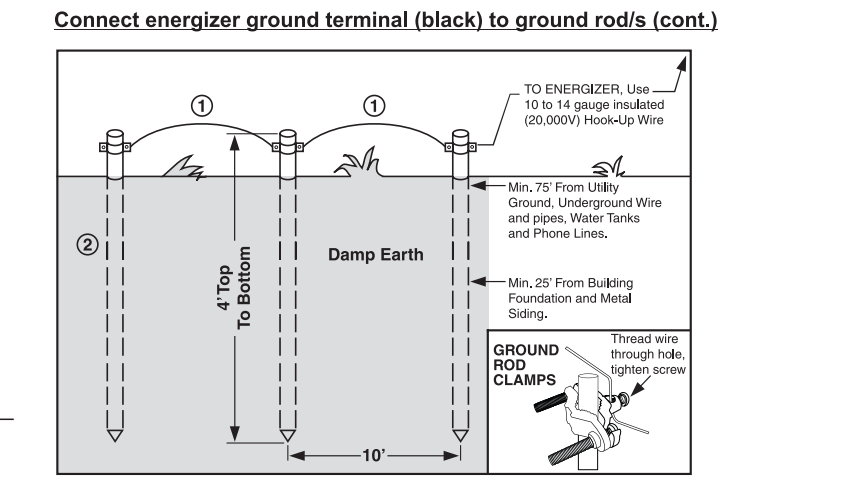

- Diagram 1: Ground System Installation**
1. 12-14 gauge galvanized fence wire.
 2. Ground rods – 4-6 feet (6 feet preferred) long by 1/2" (or more) in diameter, galvanized steel rods.

Installation STEP 4: Verify that your ground system is working.

The quality of your ground system is vital to maximizing the performance of your fence energizer. During dry seasons or during seasons when there is excessive growth of vegetation on the fence line, it may be necessary to upgrade your ground system with extra ground rods.

To test the quality of your ground system:

1. Unplug your fence energizer.
2. Place the fence under heavy load by "shorting" the fence as follows: At a location on the fence at least 100 yards from the energizer, lean 3 or 4 steel stakes or T-posts against the "hot" wire of the fence. Alternatively, you may push several pieces of fence wire into the earth and wrap the opposite end around the hot wire.
3. Plug the energizer in and turn it on to High and check the fence line voltage with a volt meter. You want to see that the voltage has dropped below 2,000V due to shorting the fence. Continue to short the fence by leaning steel posts or by making wire connections to ground at 100 yards distance or more from the energizer until the fence line voltage drops below 2,000V.

continued on next page....