



POWERSPORTS

## CAUTION

THIS ATV WAS SHIPPED WITHOUT ENGINE OIL. ALWAYS FILL WITH THE CORRECT AMOUNT AND GRADE OF ENGINE OIL AS LISTED IN THE OWNER'S MANUAL

# ASSEMBLY/PRE-RIDE INSPECTION INSTRUCTIONS

## AT200-B

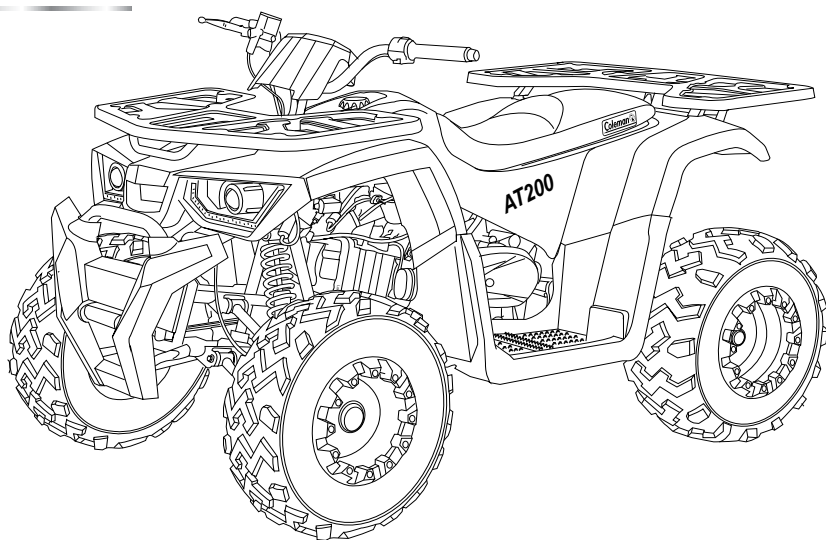

FOR QUESTIONS ABOUT THESE ASSEMBLY INSTRUCTIONS, CALL COLEMAN POWERSPORTS 888-405-8725

## **⚠** WARNING

NEVER ATTEMPT TO START THIS ATV WITHOUT READING AND UNDERSTANDING THE OWNER'S/ OPERATOR'S MANUAL. THE OWNER'S OPERATOR'S MANUAL PROVIDES INFORMATION ON SAFETY, PARTS, FUNCTIONS, PRE-RIDE INSPECTION, STARTING AND MAINTENANCE

# PARTS

## OWNER'S MANUAL



## TOOL KIT

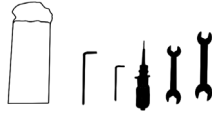

## FUEL VENT TUBE



## HANDLEBAR BRACKET CLAMPS

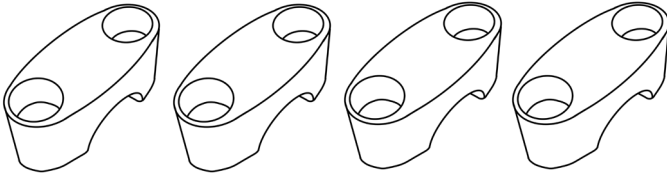

## FRONT BUMPER

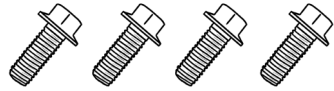
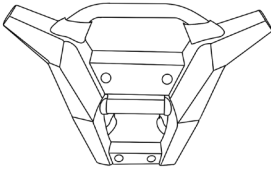

M8 x 20 Bolts

## REAR CARRIER ASSEMBLY

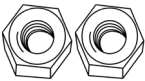

M8 Lock Nuts

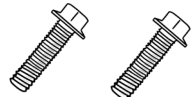

M8 x 30 Bolts

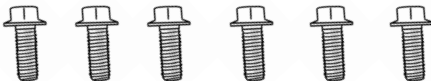

M8 x 16 Bolts



Rear Carrier Support

# PARTS (continued)

## TIRE ASSEMBLY

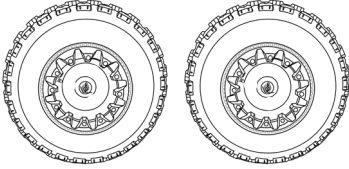

Front Tires

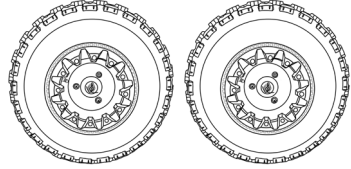

Rear Tires

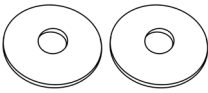

M20 Washers

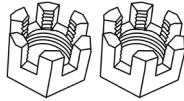

M20 Castle Nuts

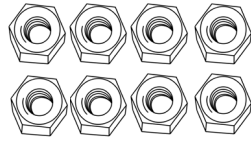

M10 Lock Nuts

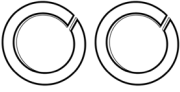

M20 Lock Washers



Cotter Pins



M10 Washers



Hub Caps



Hub Caps

## DISPLAY CONSOLE ASSEMBLY

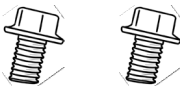

M6 X 16 Bolts

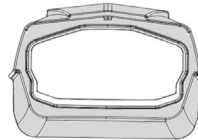

## BATTERY



# HANDLEBAR INSTALLATION

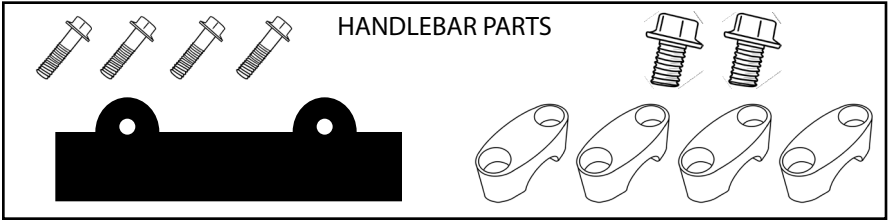

**1. Attach bottom clamp brackets to steering assembly bracket using M10 x 30 bolts, M10 Lock Washers and M10 Lock Nuts**

Handlebar Clamp Bracket  
Steering Assembly Bracket

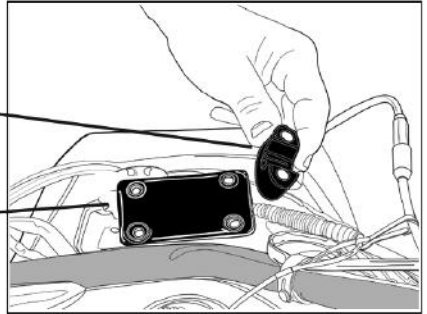

Display Console Bracket

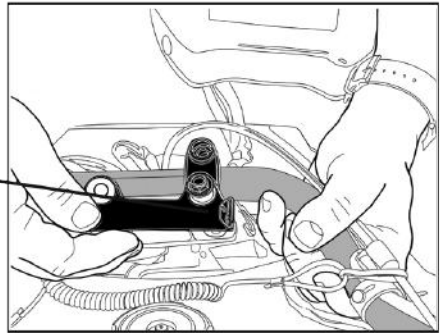

Handlebar

Display Console Bracket

M10 x 30 Bolts

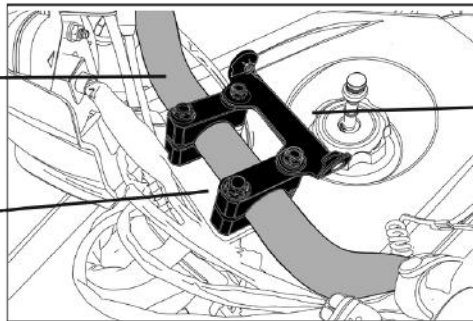

# DISPLAY CONSOLE INSTALLATION

## HANDLEBAR PARTS

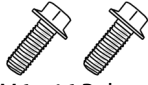

M6 x 16 Bolts

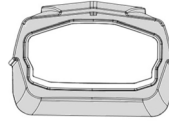

**1. Attach bottom side of display console to the display console bracket using 2 - M6 x 16 bolts**

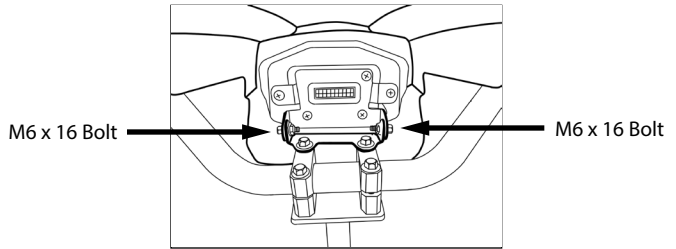
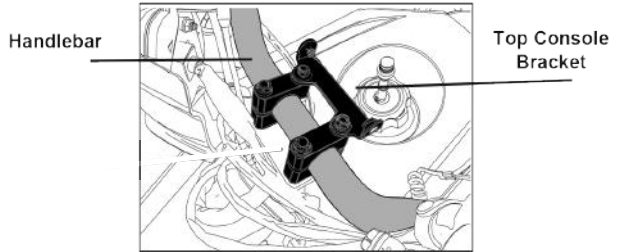

# REAR WHEEL INSTALLATION

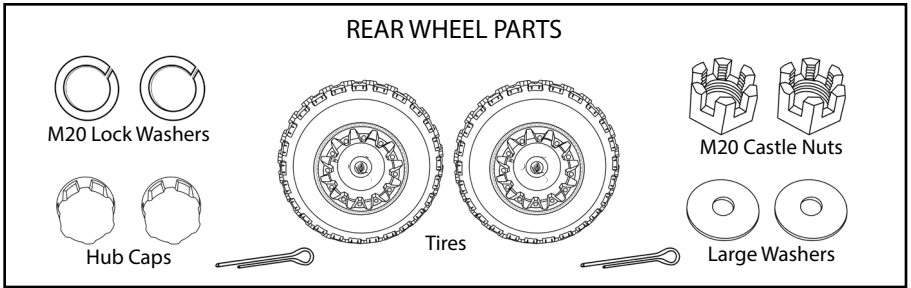

1. Fill tires with 10 PSI of air before assembly.
2. Install each wheel - ensure the tread faces forward and valve stems face out.
3. Attach each wheel using large M20 Washer, M20 Lock Washer, and M20 Castle Nut
4. Install Cotter Pin through axle end and bend over the ends.
5. Install Hub Caps

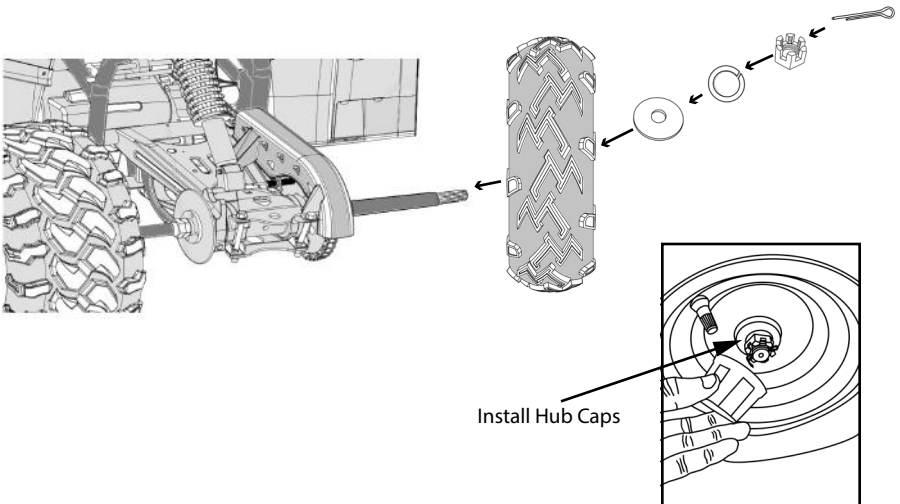

# FRONT WHEEL INSTALLATION

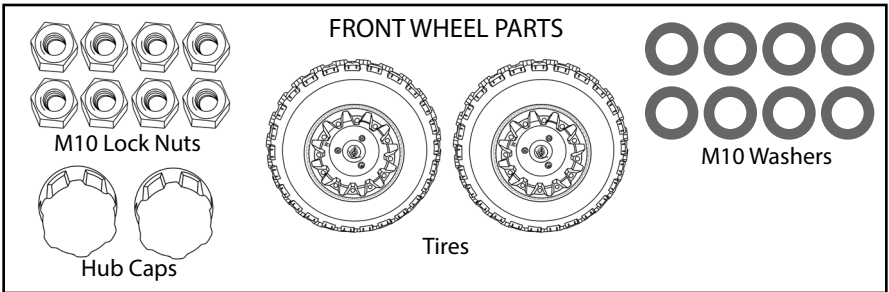

1. Fill tires with 10 PSI of air before assembly.
2. Install each wheel - ensure the tread faces forward and valve stems face out.
3. Attach each wheel with M10 Washer followed by M10 Lock Nut. Repeat for each wheel stud (Torque nuts 25ft. lbs)
4. Install Hub Caps

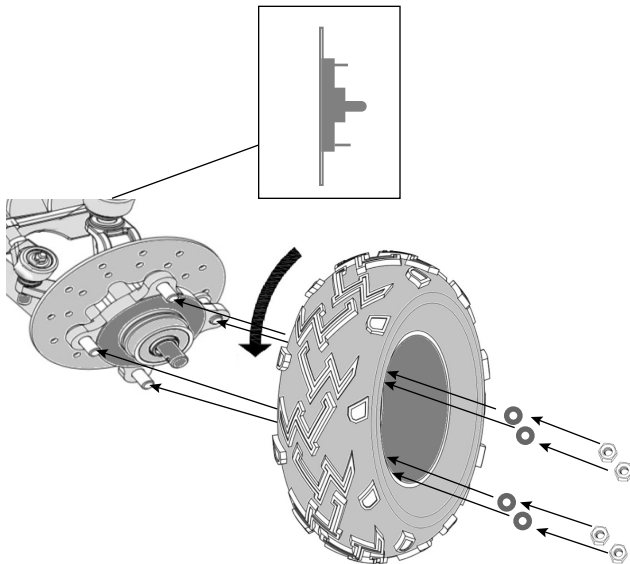

# FRONT BUMPER INSTALLATION

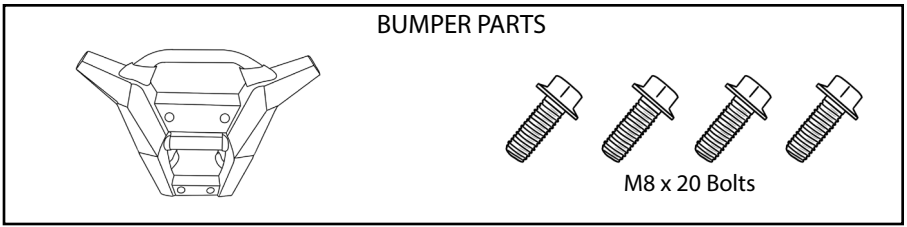

- 1. Install front bumper to front frame with M8 x 20 Bolts**

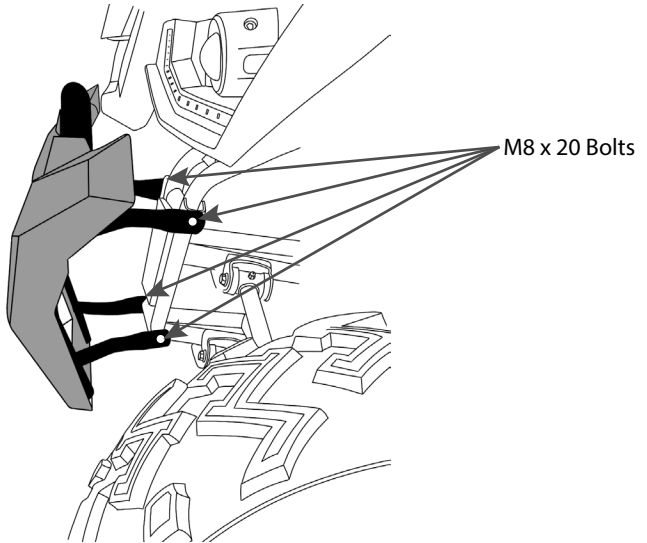



# REAR CARRIER INSTALLATION

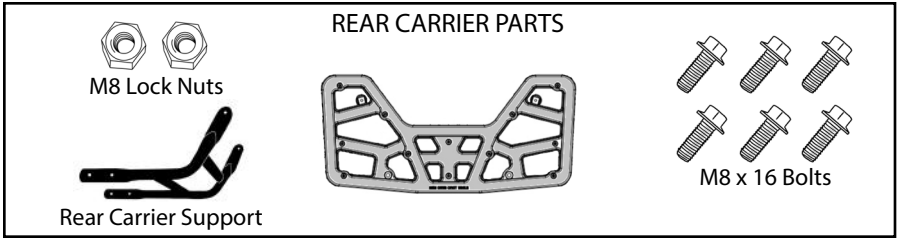

1. Install Rear Carrier Support with 4 - M8 x 16 bolts to the rear frame.
2. Attach Rear Carrier to Rear Carrier Support with 2 - M8 x 16 bolts and 2 - M8 x 30 bolts.

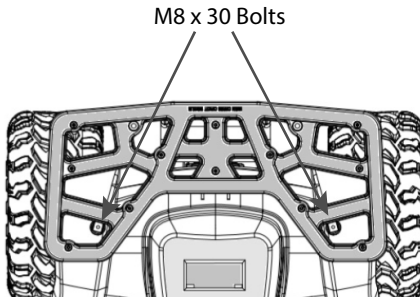
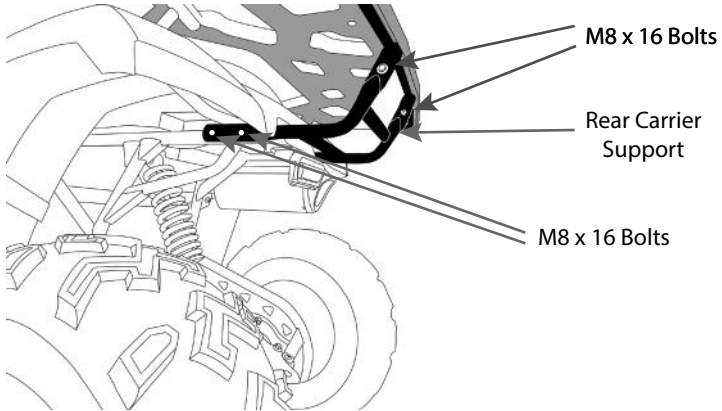

# BATTERY INSTALLATION

## BATTERY INSTALLATION

1. Insert battery into battery tray with the battery terminal nuts and bolts already installed on the battery.
2. Attach both battery straps.
3. Remove battery terminal nuts and bolts from battery.
4. Connect positive cable to positive battery terminal and re-screw battery terminal bolt.
5. Connect negative cable to negative battery terminal and re-screw battery terminal bolt.
6. Reinstall seat.

## NOTICE

Positive (+) cable is red in color.  
Negative (-) cable is black in color.

## TIP

This Coleman Powersports AT200 ATV has two positive (+) cables red in color. Both attach to the positive terminal on battery.

## WARNING

Battery electrolyte is poisonous and dangerous, contains sulfuric acid, which can cause severe burns. Avoid contact with skin, eyes or clothing. Always shield your eyes when working near batteries.

KEEP OUT OF REACH OF CHILDREN.  
DO NOT OPEN BATTERY.

Ventilate when charging or using in an enclosed space.

KEEP AWAY FROM SPARKS, FLAMES,  
CIGARETTES OR OTHER SOURCES OF  
IGNITION.

Battery

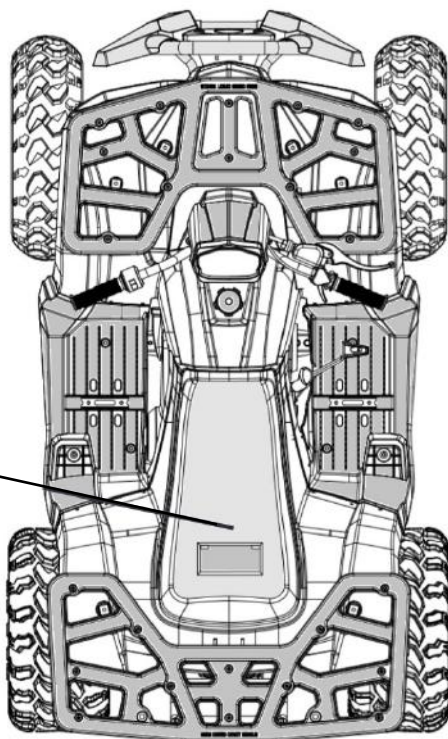

# PRE-RIDE INSPECTION

Inspecting and checking the condition of the ATV before each ride is important. Following the pre-ride checklist will help ensure that you do not have mechanical issues which could result in severe injury or becoming stranded. Make sure the ATV is in good operating condition before each ride.

## **WARNING**

Failing to inspect and maintain your ATV could be hazardous.

Not following the pre-ride inspection procedures could result in an accident or damage to the ATV.

**ALWAYS PERFORM A PRE-RIDE INSPECTION BEFORE EACH RIDE.**

## **WARNING**

Performing maintenance and inspection checks while the engine is running could be hazardous.

You could be severely injured by moving parts or hot surfaces.

**NEVER** perform maintenance or check procedures while the engine is running with the exception of checking the ignition switch or throttle.

WHAT TO CHECK	CHECK FOR
Steering	<ul style="list-style-type: none"> <li>• Smoothness</li> <li>• No restriction of movement</li> </ul>
Brakes	<ul style="list-style-type: none"> <li>• Correct fluid level</li> <li>• Inspect hoses for leaks</li> <li>• Inspect brake pads for wear</li> </ul>
Tires	<ul style="list-style-type: none"> <li>• Proper tire pressure</li> <li>• Proper tread depth</li> <li>• Rubber has no cracks</li> </ul>
Fuel Tank	<ul style="list-style-type: none"> <li>• Sufficient fuel for the ride</li> <li>• Fuel cap is secure</li> <li>• Hoses have no signs of cracks or leaks</li> </ul>
Throttle	<ul style="list-style-type: none"> <li>• Thumb throttle snaps back to idle when released</li> <li>• Operates freely</li> </ul>
Kill Switch	<ul style="list-style-type: none"> <li>• Switch shuts off engine when activated</li> </ul>
Engine Oil	<ul style="list-style-type: none"> <li>• Correct oil level</li> <li>• Dipstick is tight/secure</li> </ul>
Drive Chain	<ul style="list-style-type: none"> <li>• Proper tension</li> <li>• Lubricated</li> <li>• No excessive wear or damage</li> </ul>
General Condition	<ul style="list-style-type: none"> <li>• All nuts and bolts are tight</li> <li>• No rattles from engine or frame while running</li> </ul>

 **WARNING**

NEVER ATTEMPT TO START THIS ATV WITHOUT READING AND UNDERSTANDING THE OWNER'S/ OPERATOR'S MANUAL. THE OWNER'S/ OPERATOR'S MANUAL PROVIDES INFORMATION ON SAFETY, PARTS, FUNCTIONS, PRE-RIDE INSPECTION, STARTING AND MAINTENANCE



**POWERSPORTS**

**(888) 405-8725**

**1775 E. University Dr., Tempe, AZ 85281**  
**[www.colemanpowersportsusa.com](http://www.colemanpowersportsusa.com)**

---

**[www.facebook.com/colemanpowersportusa.com](https://www.facebook.com/colemanpowersportusa.com)**  
**[www.instagram.com/colemanpowersports\\_usa](https://www.instagram.com/colemanpowersports_usa)**

