

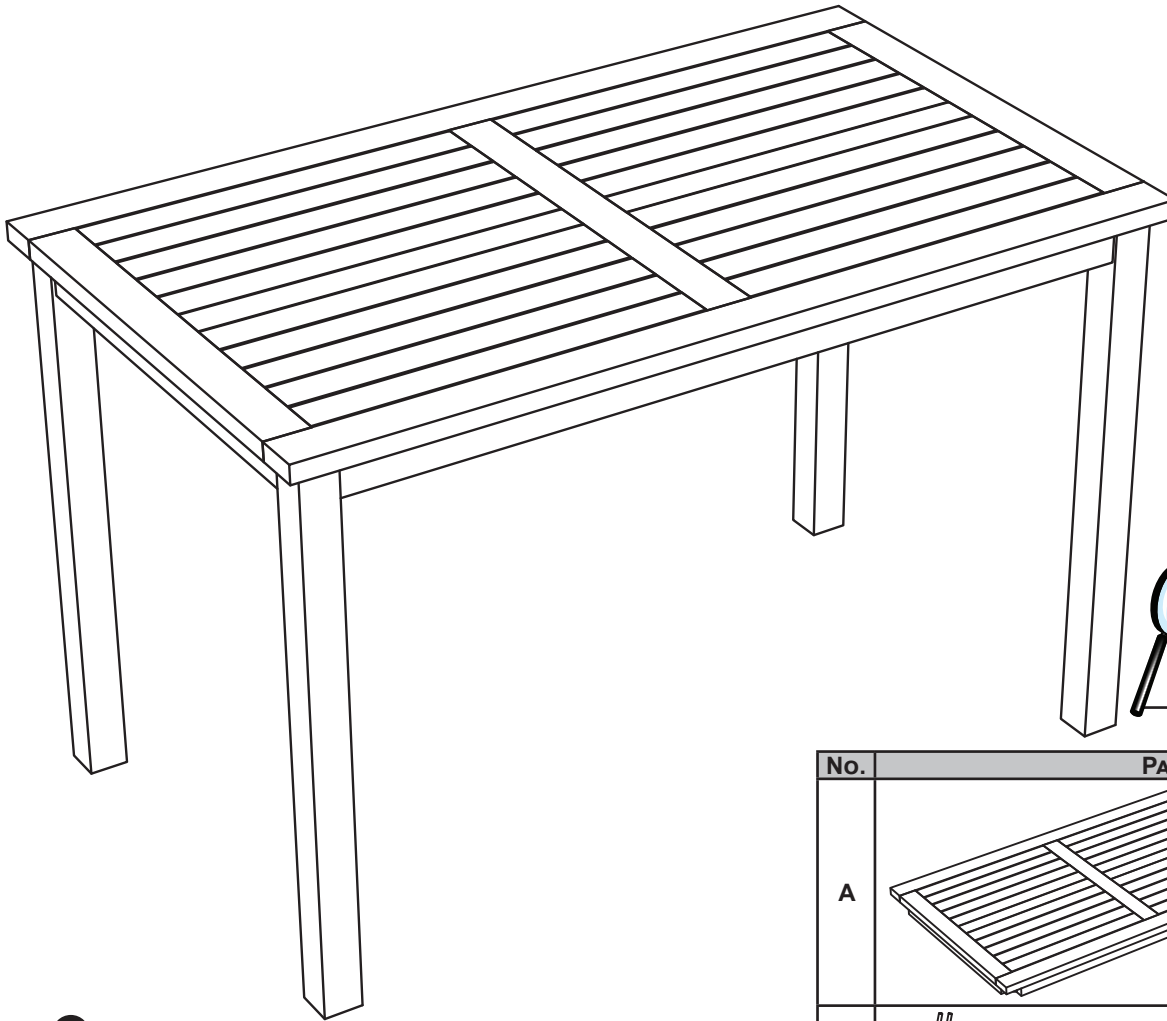

TEAK PATIO TABLE





JVA-360

Review all assembly and care information before using this product. Save this manual for future reference.
Assemble components on a soft, clean surface to avoid damaging the finish.

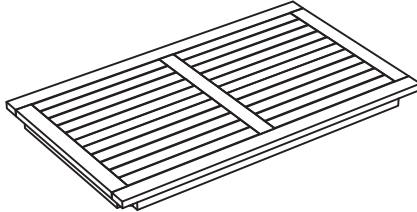
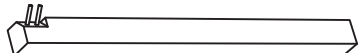

 Inspect packaging to ensure all parts are accounted for before disposing of packing materials.
 Save the packing slip.

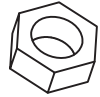
200
pounds
91 kg
Weight Capacity

No.	PARTS	QTY.
A	 Tabletop	1
B	 Leg	4
C	 Washer	8
D	 Nut	8
E	 Spanner	1

! WARNING !

CHOKING HAZARD — This item contains small parts that can be swallowed by children. Keep children away during assembly.

! WARNING:

Manufacturer and seller expressly disclaim any and all liability from personal injury, property damage or loss, whether direct or indirect, or incidental, resulting from the incorrect attachment, improper use, inadequate maintenance, or neglect of this product.

ASSEMBLY

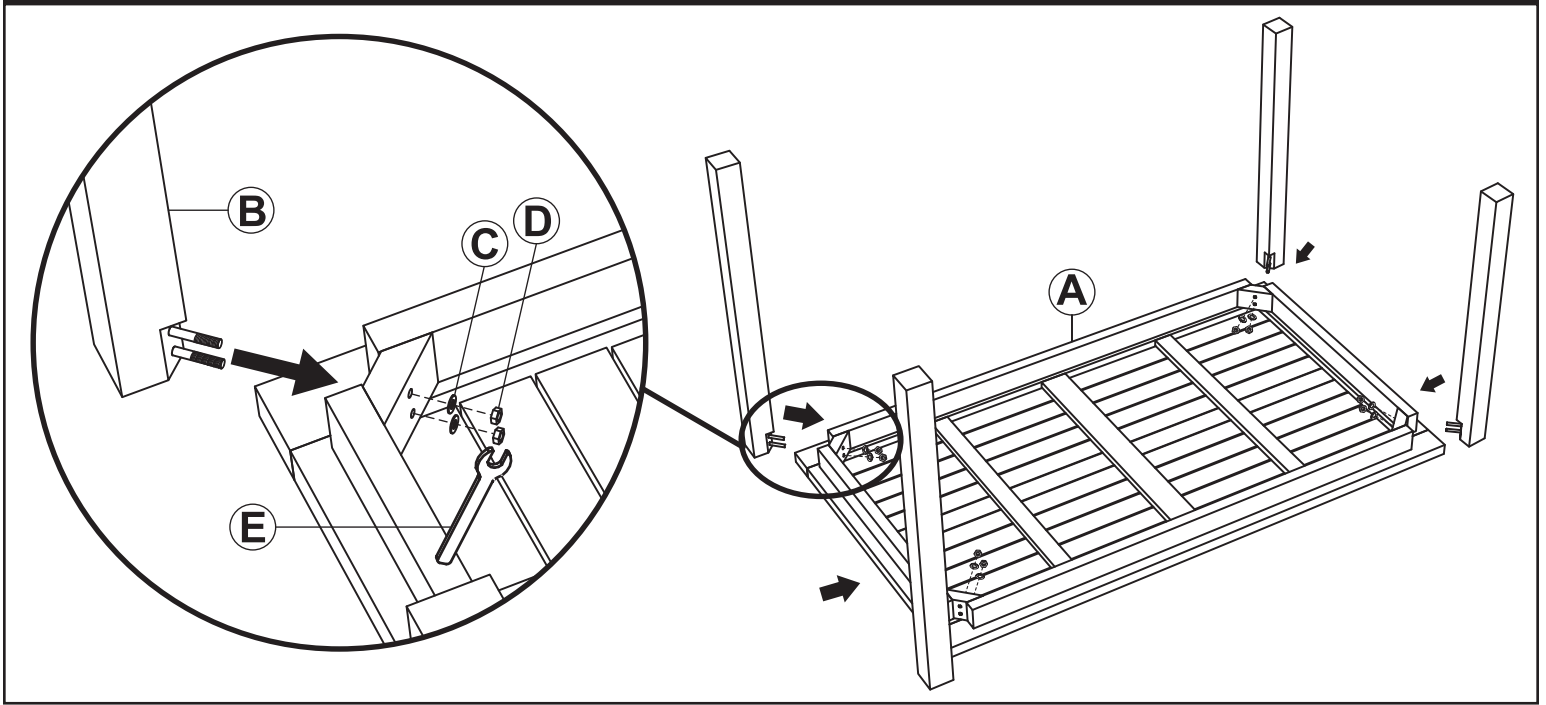

Care & Maintenance

Use this guide to help easily maintain and care for your teak furniture. Teak wood has a natural resistance to mold and rot; however, unsightly mildew can still form on the surface of the wood if not cared for. Regular cleanings will help prevent discoloration on both treated and untreated wood.

SAFE USE: Do not stand or sit on the table. Only use on a flat, level surface.

COVER: When not in use, cover the furniture with a breathable cover to help protect it from dust build-up, collecting debris, and the effects of long-term sun exposure.

WINTER CARE & STORAGE: Protect wooden furniture from inclement weather, especially ice and snow. Move to a cool, dry indoor location. Covering while in storage is recommended to help prevent dust build-up.

CLEANING: Regular cleaning of your teak will help prevent mildew build-up and potential discoloration.

Wet down the furniture with clean water. Mix 1 cup of vinegar with 1 gallon of water and use a soft plastic brush to scrub the furniture. Do not use metal brushes as they can scratch and damage the wood's surface.

Rinse thoroughly with clean water. Place the furniture in a shaded area to dry; do not allow it to dry in direct sunlight. Allow at least 24 hours of dry-time before using or attempting to clean it again. Some harder to clean stains may require a store-bought teak cleaner. When cleaning your teak, always start with the mildest cleaning solution. Follow store-bought cleaner instructions carefully.

MAINTENANCE: Left untreated, the wood may weather. A suitable wood oil may need to be applied at least once per year or when the wood looks particularly dry. Follow application instructions, as noted with the suitable wood oil (not included).

WARNING: THE ONE-YEAR WARRANTY DOES NOT COVER DAMAGES OR DEFECTS CAUSED BY THE APPLICATION OF CHEMICAL TREATMENTS, PROTECTIVE COATINGS, OR CLEANING PRODUCTS.

! SAFETY STATEMENTS & WARNINGS !

- For residential use only.
- Do not exceed the weight capacity of the furniture.
- Do not put hot items on or near furniture.
- Keep furniture a safe distance from heat sources such as fire pits, patio heaters, and grills.
- Do not allow children to use this product without adult supervision.
- Do not use harsh chemicals or abrasive materials to clean the furniture.

Any modification to the product or failure to follow recommended care will void the product warranty.

If you experience issues with assembly or the product was damaged during shipping, please contact our customer service team through one of the methods mentioned at the top of page 1. Please have the item number and order information ready to expedite response time.