

16698



Call Us First!
DO NOT RETURN TO STORE.

For immediate help with assembly or product information

call our toll free number:

1-888-827-9056

or email:

customerservice@backyardproductsllc.com

Our staff is ready to provide assistance

March through November

M-F 8:00 AM to 9:00 PM EST / 6:00 PM PST

Saturday 8:30 AM to 5:00 PM EST / 2:00 PM PST

December through February

M - F 8:00 AM to 8:00 PM EST / 5:00 PM PST

Saturday 8:30 AM to 5:00 PM EST / 2:00 PM PST

(This page intentionally left blank.)

8' x 12' Gable (243,8 x 365,8 cm)

KEEP THIS MANUAL FOR FUTURE REFERENCE

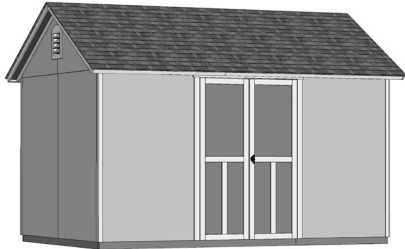

OPTIONAL:
DOOR CENTERED
ON EAVE WALL

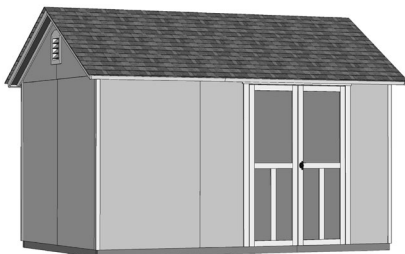

OPTIONAL:
DOOR OFFSET
ON EAVE WALL

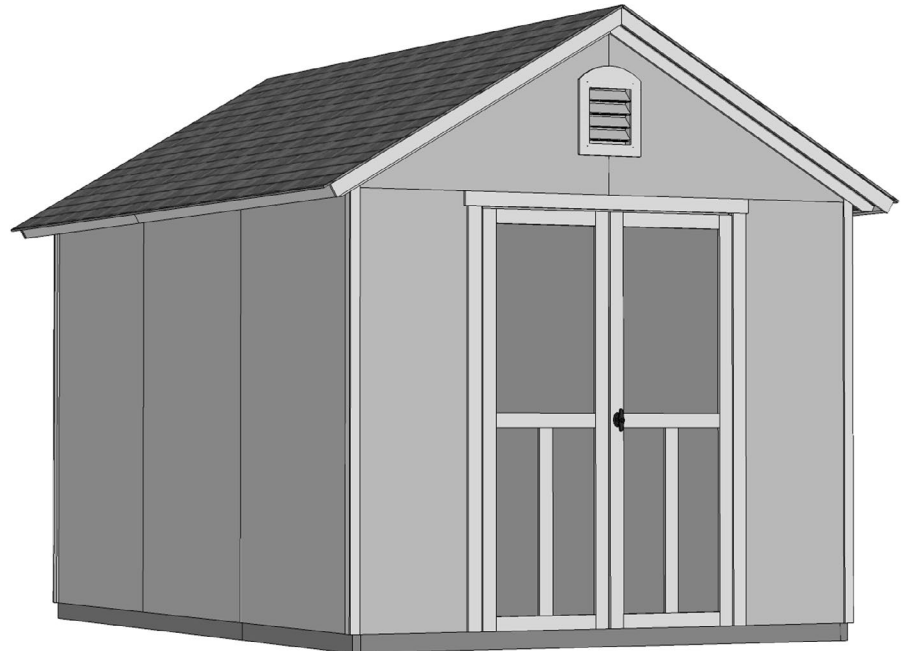

Building 12' x 8'
(365,8 x 243,8 cm)

⚠ IMPORTANT! ⚠

READ INSTRUCTIONS THOROUGHLY PRIOR TO BEGINNING ASSEMBLY.

BEFORE YOU BEGIN

• **BUILDING RESTRICTIONS AND APPROVALS**

Be sure to check local building department and homeowners association for specific restrictions and/ or requirements before building.

• **ENGINEERED DRAWINGS**

Contact our Customer Service Team if engineered drawings are needed to pull local permits.

• **SURFACE PREPARATION**

To ensure proper assembly you must build your shed on a level surface. Recommended methods and materials to level your shed are listed on page 7.

• **CHECK ALL PARTS**

Inventory all parts listed on pages 4-6.

• **ADDITIONAL MATERIALS**

You will need additional materials to complete your shed. See page 3 for required and optional materials and quantities.

*****CONTACT OUR CUSTOMER SERVICE TEAM
IF ANY PARTS ARE MISSING OR DAMAGED*****

- Order form and warranty at back of manual -

Call: 1-888-827-9056 email: customerservice@backyardproductsllc.com



TOOLS

Required

Phillips Screwdriver 

Drill / Driver
 3/8" Drill Bit
 #2 Phillips Drive Bit

Hammer 

Pencil 

Tape Measure 

Square 

Level 

Chalk Line 

Utility Knife
 Shingle Blades 

Caulk Gun 

Ladder 

Paint Tools 

Optional

Tool Belt/
Nail Pouch 

Safety Glasses 

Nail Gun
• Gun Nails 

Gloves 

Clamps 

Safety! Always use approved safety glasses during assembly.

HELPFUL REMINDER SYMBOLS

Look for these symbols for helpful reminders throughout this manual.

 = Assistance Required; or more people.

 = Ensure squareness.

 = Important required step or operation.

 = Helpful assembly hint.

 = Mark part with pencil.

 **BEGIN** = Beginning of steps for assembly or installation.

 **FINISH** = You have finished the assembly or installation.

 = Level

ORIENT LUMBER AND TRIM FOR BEST APPEARANCE

Framing lumber is graded for structural strength and not appearance. Exterior trim is graded for one good side.

Always install the material leaving the best edge and best surface visible. Please remember that these blemishes in no way negatively affect the strength or integrity of our product. (See Fig. A, B, C.)

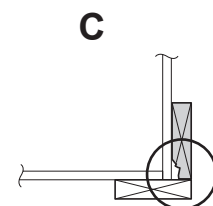
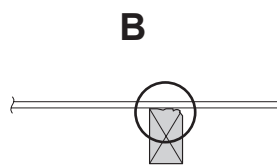
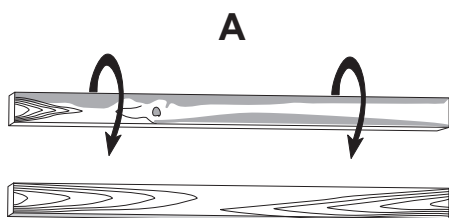

ADDITIONAL MATERIALS

FOUNDATION OR FLOOR MATERIALS

- If your shed was purchased with a floor, see floor kit hardware bag for assembly instructions.
- See the FLOOR LEVELING section on page 7 for recommended methods and suggested materials to properly level your floor, as this will vary depending on your specific site.

REINFORCED WOOD FLOOR FRAME (OPTIONAL)

IMPORTANT! Depending on your specific use, you may want to construct a heavy duty floor frame by adding additional floor joists (shown below as shaded). Below is a list of additional materials (not included).

- x3** 2 x 4 x 8' (5,1 x 10,2 x 243,8 cm) Treated Lumber
Cut lumber to 2 x 4 x 93" (5,1 x 10,2 x 236,2 cm)
Treated Lumber
- x12** ea. 3" (7,6 cm) hot-dipped galvanized nails

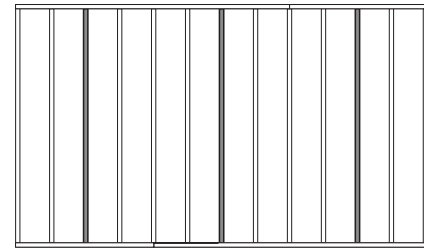

→ | ← Optional 12" (30,5 cm) spacing

COMPLETING YOUR SHED

You will need these additional materials:

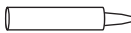
- | | |
|---|--|
| <input type="checkbox"/> 3-TAB SHINGLES6 Bundles | <input type="checkbox"/> 1" GALVANIZED ROOFING NAILS 3 Lbs
For shingles. |
| <input type="checkbox"/> PAINT FOR SIDING2 Gallons
Use 100% acrylic latex exterior paint. (2) coats recommended. | <input type="checkbox"/> PAINT FOR TRIM 1 Quart
Use 100% acrylic latex exterior paint. |
| <input type="checkbox"/> CAULK3 Tubes
Use acrylic latex exterior caulk that is paintable.  | <input type="checkbox"/> 1" GALVANIZED ROOFING NAILS ... 1/4 Lb
For roofing felt. |
| <input type="checkbox"/> DRIP EDGE 50 Feet | <input type="checkbox"/> #15 ROOFING FELT
To cover 159 Sq. Ft. of roof area. |



TO VALIDATE YOUR WARRANTY YOU MUST USE THE FOLLOWING:



- CAULK** 1 Tube
For windows use acrylic latex exterior caulk that is paintable.

REFER TO THE BACK OF THIS MANUAL AND THE MANUFACTURER'S INSTRUCTIONS FOR INSTALLATION OF SHINGLES, DRIP EDGE AND FELT.

PARTS IDENTIFICATION AND SIZES

Part identification is stamped on some parts.

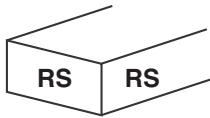

• Check these locations for Part stamps

WOOD SIZE CONVERSION CHART

Nominal Board Size	Actual Size
2 x 41-1/2" x 3-1/2" (3,8 x 8,9 cm)
1 x 43/4" x 3-1/2" (1,9 x 8,9 cm)
2 x 31-1/2" x 2-1/2" (3,8 x 6,3 cm)
1 x 33/4" x 2-1/2" (1,9 x 6,3 cm)

PARTS LIST



INVENTORY YOUR PARTS before you begin.

We suggest sorting parts by the category they are listed in.

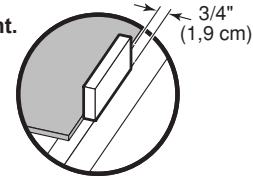

WALLS

- x1 **GAA** 1 x 3 x 5" (2,5 x 7,6 x 12,7 cm) **GAUGE BLOCK for 3/4" (1,9 cm) measurement.**
- x4 **AL** 2 x 4 x 7" (5,1 x 10,2 x 17,8 cm)
- x2 **SP** 2 x 4 x 48" (5,1 x 10,2 x 121,9 cm)
- x1 7/16 x 3-1/4 x 50-3/4" (1,1 x 8,3 x 128,9 cm) **OSB**
- x2 **TCA** 2 x 4 x 51" (5,1 x 10,2 x 129,5 cm)
- x2 **YFA** 2 x 4 x 68-1/2" (5,1 x 10,2 x 174 cm)
- x25 **TM** 2 x 4 x 72" (5,1 x 10,2 x 182,9 cm)
- x4 **SZ** 2 x 4 x 89" (5,1 x 10,2 x 226,1 cm)
- x2 **TP** 2 x 4 x 96" (5,1 x 10,2 x 243,8 cm)

ROOF

- x12
- x14 **TZA** 2 x 4 x 55-9/16" (5,1 x 10,2 x 141,1 cm)
- x4 **NXC** 2 x 4 x 62-3/16" (5,1 x 10,2 x 158 cm)
- x2 **JF** 1 x 4 x 60 (2,5 x 10,2 x 152,4 cm)

TRIM

- x2 **HUL** 19/32" x 3-1/2 x 62-3/16" (1,5 x 8,9 x 158 cm)
- x2 **HUR** 19/32" x 3-1/2 x 62-3/16" (1,5 x 8,9 x 158 cm)
- x2 **YOR** 19/32" x 2-1/2 x 63-1/16" (1,5 x 6,3 x 160,2 cm)
- x2 **YOL** 19/32" x 2-1/2 x 63-1/16" (1,5 x 6,3 x 160,2 cm)
- x2 **AS** 2 x 6 x 49-1/2" (5,1 x 15,2 x 125,7 cm)
- x2 **VX** 2 x 6 x 96" (5,1 x 15,2 x 243,8 cm)
- x2 **JUB** 19/32" x 2-1/2 x 62-3/4" (1,5 x 6,3 x 159,4 cm)
- x2 **BSA** 19/32" x 2-1/2 x 91" (1,5 x 6,3 x 231,1 cm)
- x8 3/8 x 1-3/4 x 75-3/4" (1 x 4,4 x 192,4 cm)

DOOR

- x2 **EGB** 19/32" x 2-1/2 x 18-5/8" (1,5 x 6,3 x 47,3 cm)
- x2 **UWA** 19/32" x 2-1/2 x 32" (1,5 x 6,3 x 81,3 cm)
- x2 **OO** 69" (75,3 cm) Door Stiffener
- x1 **ZB** 19/32" x 2-1/2 x 55" (1,5 x 6,3 x 139,7 cm)

WALL PANEL & DOOR PARTS LIST

NOTE: Panel parts are not stamped with part identification.



x1
 $3/8 \times 3-7/8 \times 48"$
 (1 x 9,8 x 121,9 cm)

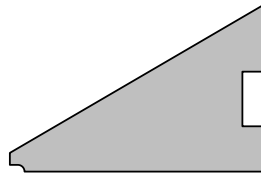

x2

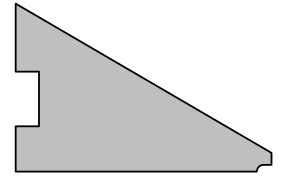

x2



x2
 $3/8 \times 23-7/8 \times 76"$
 (1 x 60,6 x 193 cm)

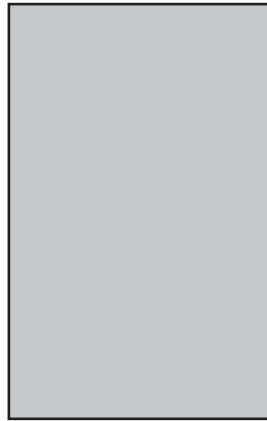

x8
 $3/8 \times 48 \times 76"$
 (1 x 121,9 x 193 cm)

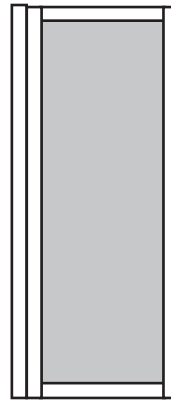

x1
LEFT DOOR

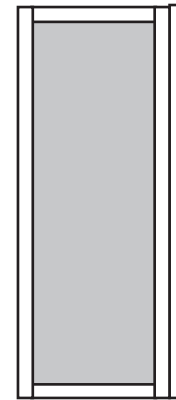

x1
RIGHT DOOR

ROOF PANELS

NOTE: Roof Panels are 7/16" (1,1 cm) thick

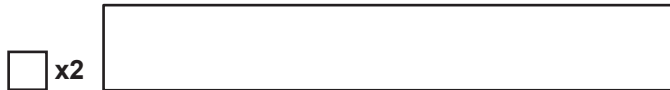

$13-7/8 \times 96"$
 (35,2 x 243,8 cm)



$48 \times 96"$
 (121,9 x 243,8 cm)

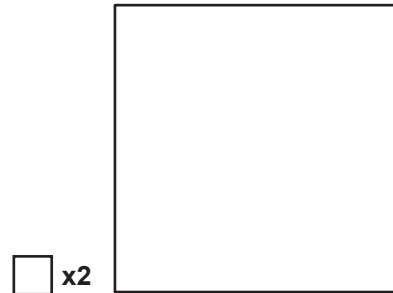







$47-7/8 \times 48"$
 (121,6 x 121,9 cm)

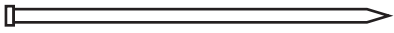

$13-7/8 \times 48"$
 (35,2 x 121,9 cm)

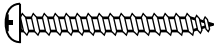
FASTENER / HARDWARE BAG

- x 160  1-1/2" (3,8 cm)
- x 120  2" (5,0 cm)
- x 65  3" (7,6 cm)
- x 55  2" (5,0 cm)
- x 88  1-1/4" (3,2)
- x 8  1" (2,5 cm)
- x 48  3/4" (1,9 cm)

NOTE:
If you are using a nail gun, nails may be used where screws are shown for quicker assembly. Length of nail must match screw length.

NAIL BOXES

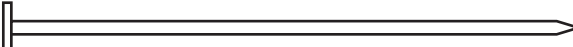
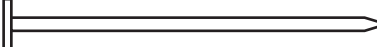
- x3 BOXES  3" (7,6 cm)
- x4 BOXES  2" (5,1 cm)

ACCESSORIES & DOOR HARDWARE

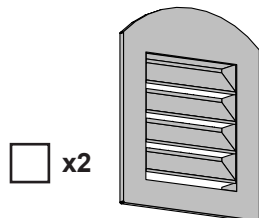
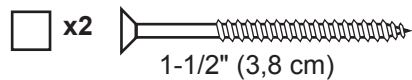
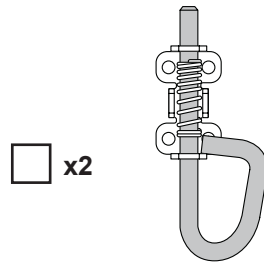
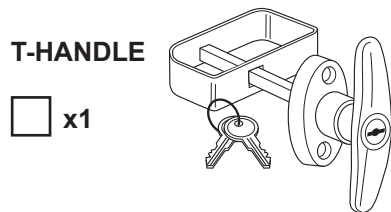

There are multiple ways to level your floor frame. Our recommended leveling method is shown below.
Leveling materials are not included in this kit.

PREFERRED METHOD - 4x4 TREATED RUNNERS

- 3" Screws angled into 4x4.
- (2) at each point frame and 4x4 touch.

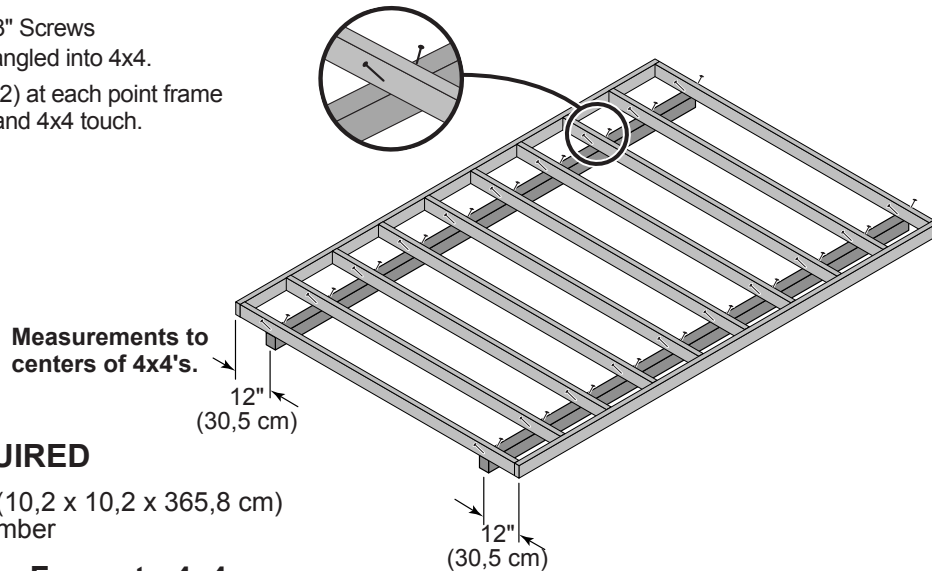

MATERIAL REQUIRED

x2 4 x 4 x 12' (10,2 x 10,2 x 365,8 cm)
Treated Lumber

Fasteners for Frame to 4x4.
(3" screws shown as one option.) Minimum (40) 3" screws / exterior grade.

⚠ Use only wood treated for ground contact and fasteners approved for use with treated wood.

⚠ Always support frame seams.

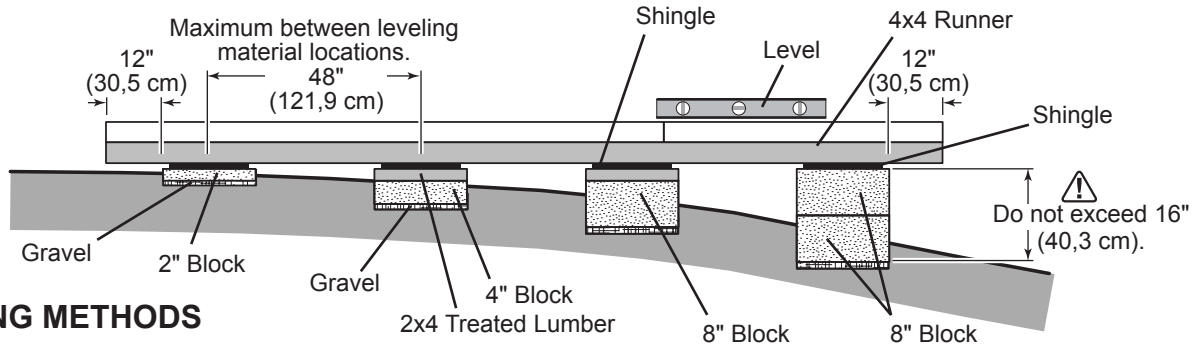

LEVELING METHODS

- Level under 4x4 runners only.
- Locate leveling material 12" (30,5 cm) from ends of runners and no more than 48" (121,9 cm) apart.
- Asphalt shingles should be used between 4x4 runners and blocks or treated lumber. Never use shingles in direct contact with ground.
- For best results and aiding in water drainage use gravel under each concrete block.

LEVELING MATERIALS

- Gravel
- Solid Masonry Blocks in 1", 2", 4" or 8" thickness
- 2x4 Treated Lumber
- Asphalt Shingles

⚠ Leveling higher than 16" (40,3 cm) not recommended.

CONCRETE

- If you are building your shed on a concrete foundation see the following page.

CONCRETE FOUNDATION

Your kit contains all materials to construct a wooden floor.
If you choose to install your kit on a concrete slab refer to the diagram below.

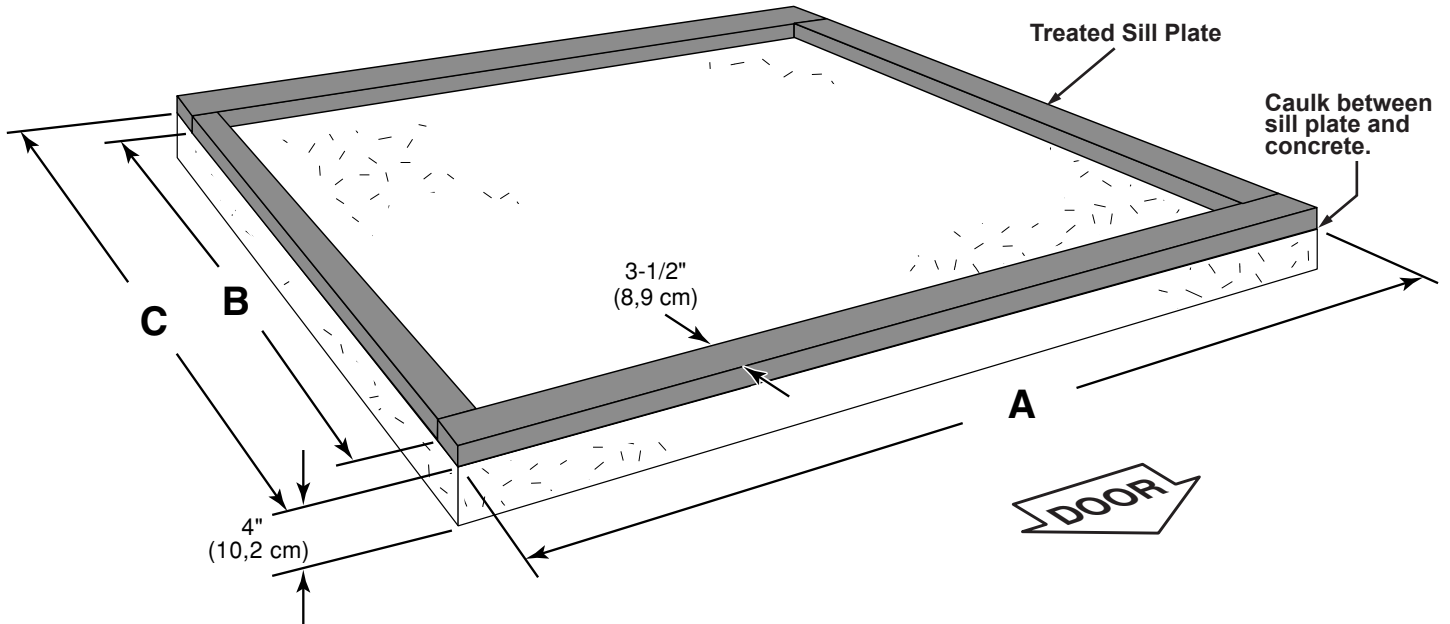

Building Size	Actual Size	A	B	C
8' x 12' (365,8 x 243,8 cm)	96" x 144" (243,8 x 365,8 cm)	96" (243,8 cm)	137" (348 cm)	144" (365,8 cm)

Requires:

- x2 2 x 4 x 12' (5,1 x 10,2 x 365,8 cm) **MUST be treated lumber.**
- x2 2 x 4 x 8' (5,1 x 10,2 x 243,8 cm) **MUST be treated lumber.**
- x1 Caulk

Allow new concrete slabs to cure for at least seven (7) days.

- A treated 2 x 4 (5,1 x 10,2 cm) sill plate is required when installing your shed on concrete.
Hint: Purchase full length treated lumber.
- Use a high quality exterior grade caulk beneath all sill plates.
- Fasten 2 x 4 (5,1 x 10,2 cm) sill plates to slab using approved concrete anchors (**fasteners not included**).
- Check local code for concrete foundation requirements.

NOTES

FLOOR FRAME

STOP!



LEVEL AND SQUARE FLOOR FRAME



Before attaching floor decking, it is important to level and square the floor frame. A level and square floor frame is required to correctly construct your shed.

STOP!



✓ **BEGIN**

- 1** See page 7 for the preferred floor leveling method.
- 2** Use level and check the frame is level before applying floor panels.
- 3** Check for frame squareness by measuring diagonally across corners. If the measurements are the same, the frame is square. The diagonal measurement will be approximately 173-1/16" (439,6 cm).
- 4** When the frame is level and square secure one side of frame to the 4x4 runners using one fastener at ends of each runner. Move to the opposite end of the frame. Secure the frame to 4x4 runners using one fastener at ends of each runner making sure the frame remains square (**Fig. A**).

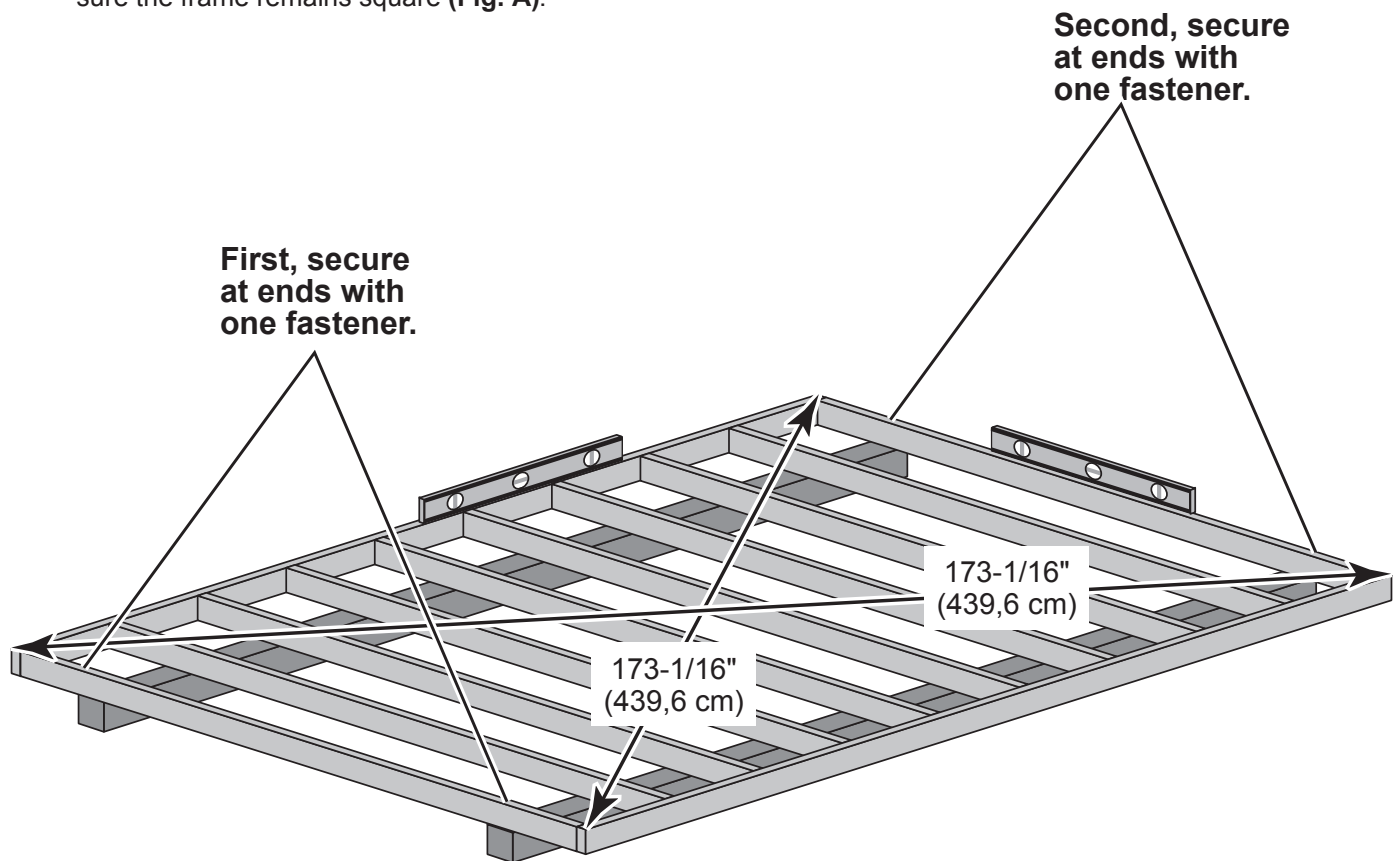

Fig. A



Once the floor frame is level and square, fasten the frame at each point where the frame contacts the 4x4 runners.

IMPORTANT!

STOP!

Check that the floor frame is level after installing floor panels.
Re-level if needed.

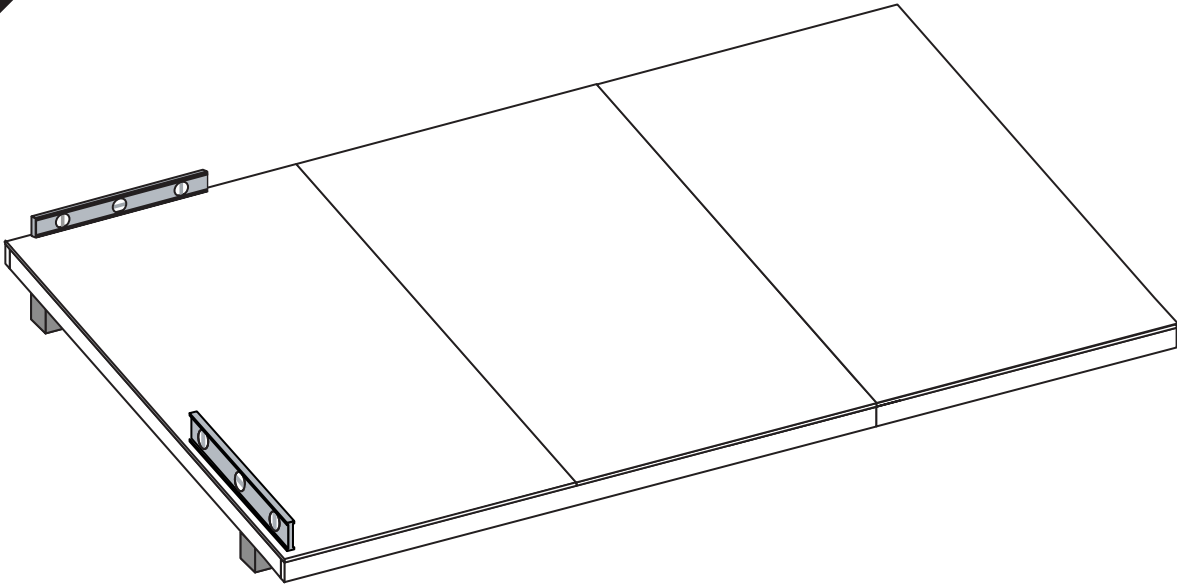

HINT:

- The floor should be used as a level work surface for wall construction.
- Organize your wall sections during sub-assembly to avoid over-handling of the walls.

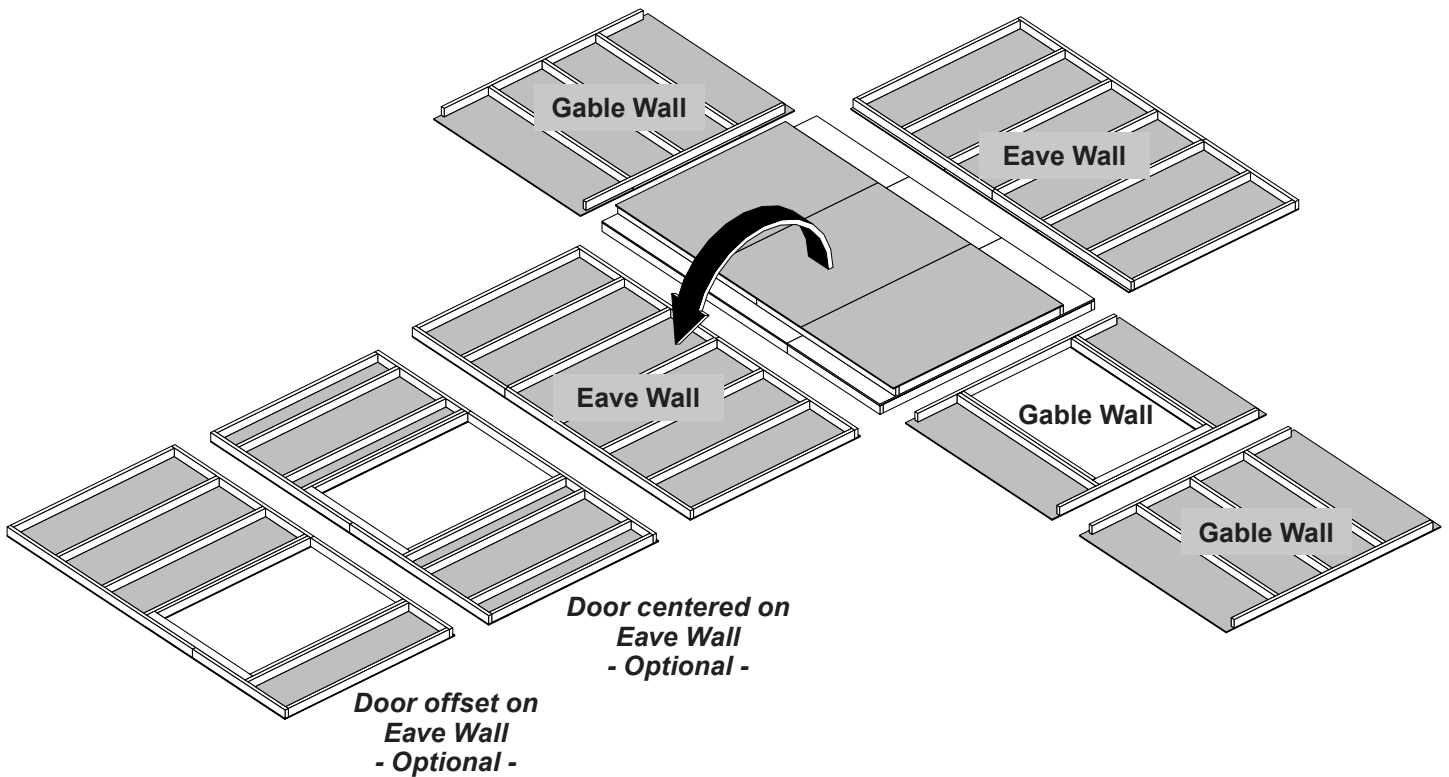

DOOR HEADER

PARTS REQUIRED:

x2 **TCA**
2 x 4 x 51" (5,1 x 10,2 x 128,9 cm)

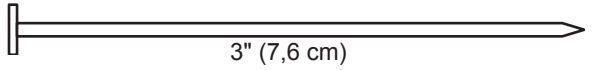
x18  3" (7,6 cm)

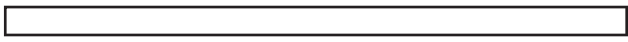
x1  **OSB**
7/16 x 3-1/4 x 50-3/4" (1,1 x 8,3 x 170,2 cm)



✓ BEGIN

- 1 Stack **TCA** and **OSB** as shown.
Nail with 3" nails in the pattern shown.

- 2 Flip header assembly over and nail as shown on the other side.

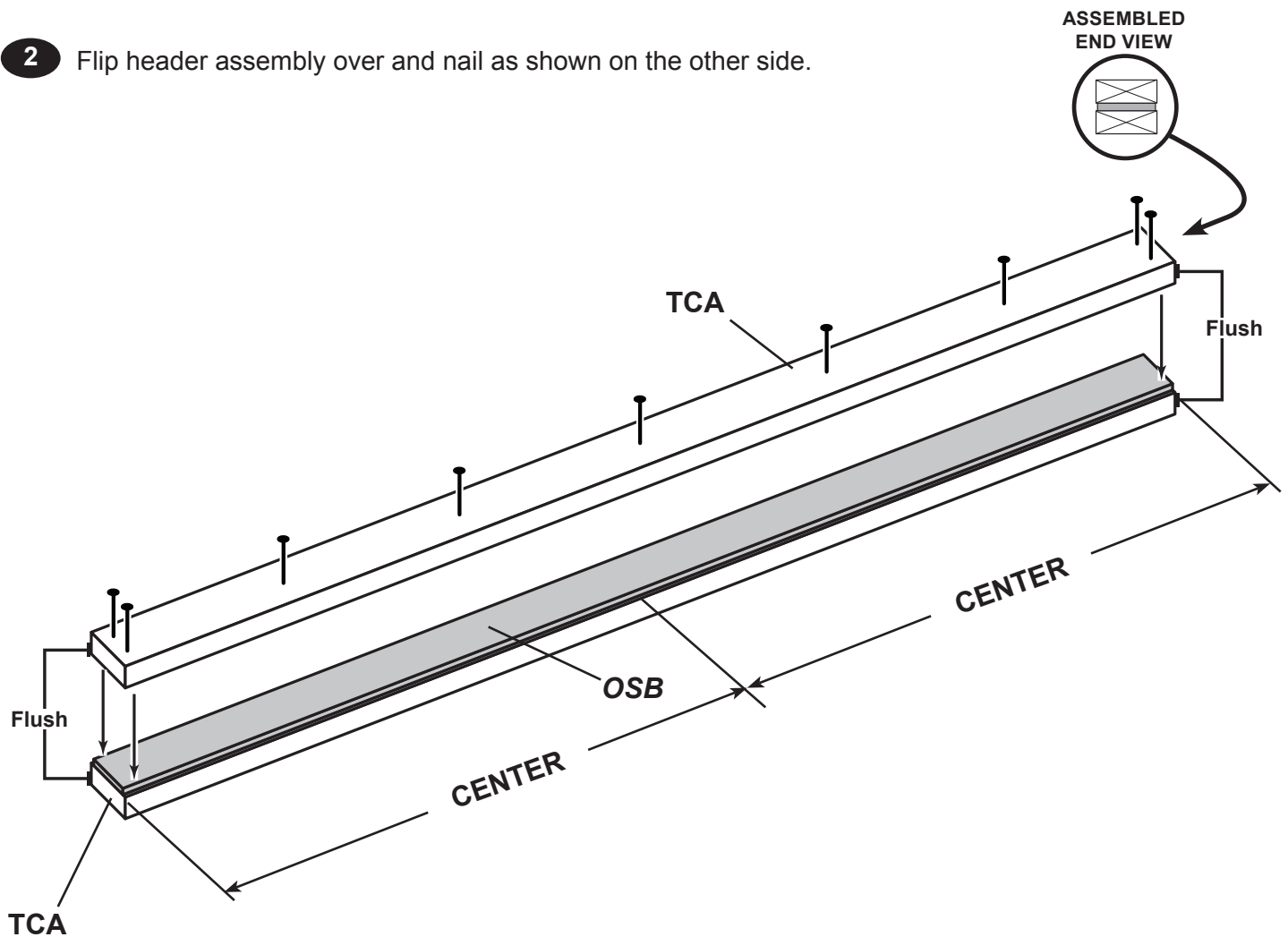

Your door header is now assembled.

**CHOOSE YOUR DOOR LOCATION AT THIS TIME
AS YOU WILL ASSEMBLE YOUR DOOR WALL FIRST.**

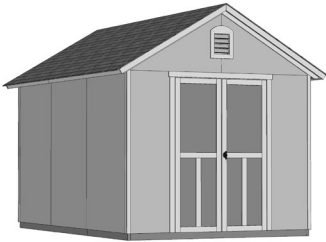

STANDARD:
DOOR LOCATED
ON 8' GABLE WALL

8' GABLE WALL WITH DOOR:



**IF YOU CHOOSE THE GABLE WALL FOR DOOR LOCATION
GO TO Page 13 TO BEGIN BUILDING YOUR WALLS.**

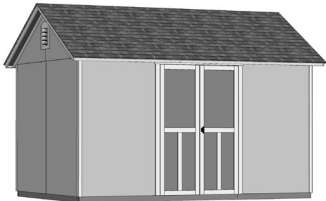

OPTIONAL:
DOOR CENTERED
ON 12' EAVE WALL

12' EAVE WALL WITH DOOR:



**IF YOU CHOOSE THE EAVE WALL WITH DOOR CENTERED
GO TO Page 15 TO BEGIN BUILDING YOUR WALLS.**



OPTIONAL:
DOOR OFFSET
ON 12' EAVE WALL

12' EAVE WALL WITH DOOR:



**IF YOU CHOOSE THE EAVE WALL WITH DOOR OFFSET
GO TO Page 17 TO BEGIN BUILDING YOUR WALLS.**

8' WALL WITH DOOR

PARTS REQUIRED:

x2 **YFA**
2 x 4 x 68-1/2" (5,1 x 10,2 x 174 cm)

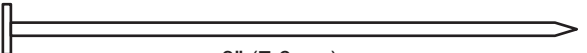
x42  3" (7,6 cm)

x2 **TM**
2 x 4 x 72" (5,1 x 10,2 x 182,9 cm)



x2 **SZ**
2 x 4 x 89" (5 x 10,2 x 226,1 cm)

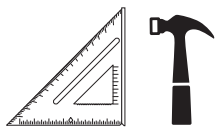

x1 **Pre Assembled Header**

✓ BEGIN

1 Orient parts on edge on floor. Measure and mark.

Maintain a 48" (121,9 cm) measurement in door opening (between YFA).

Secure with (2) 3" nails at each mark.



HINT:
For easier nailing
stand on frame.

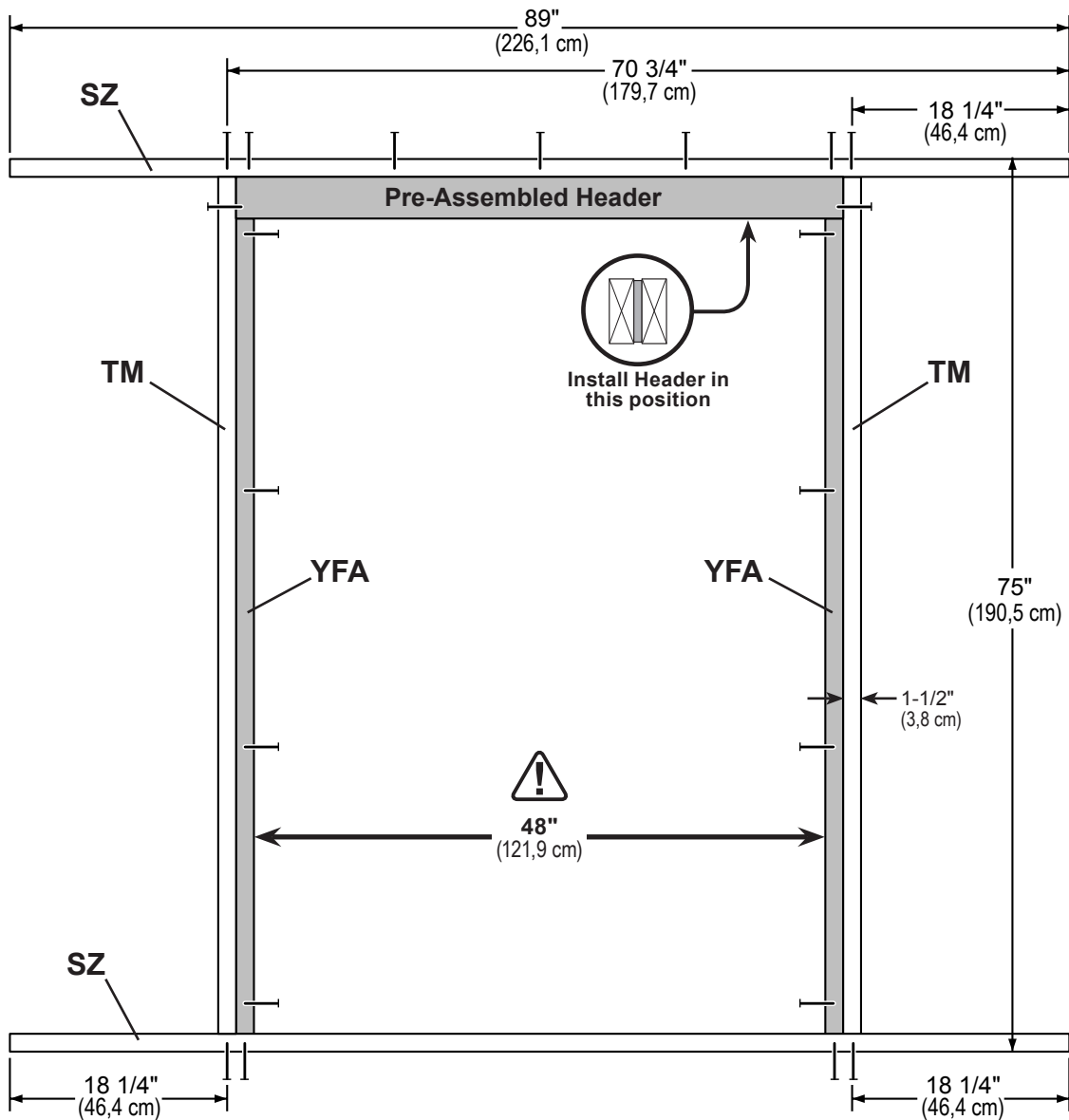
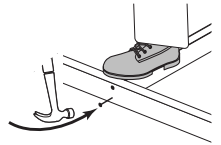

8' WALL WITH DOOR

PARTS REQUIRED:

x1 
 3/8 x 3-7/8 x 48"
 (1 x 9,8 x 121,9 cm)

x2

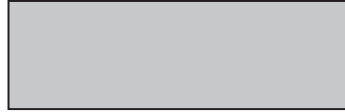

3/8 x 23-7/8 x 76"
 (1 x 60,6 x 193 cm)

x54

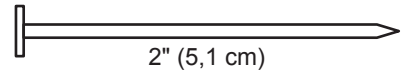

Install all panels with the primed side facing up.

- 2** Place (2) 23-7/8" x 76" panels and 3-7/8" x 48" panel on wall frame as shown. Flush all panels to top plate and flush the 23-7/8" x 76" panels along edge of door frame. Panels will overlap the frame approximately 3-1/2" (8.9 cm) at each side. Secure panels with 2" nails spaced 6" apart.

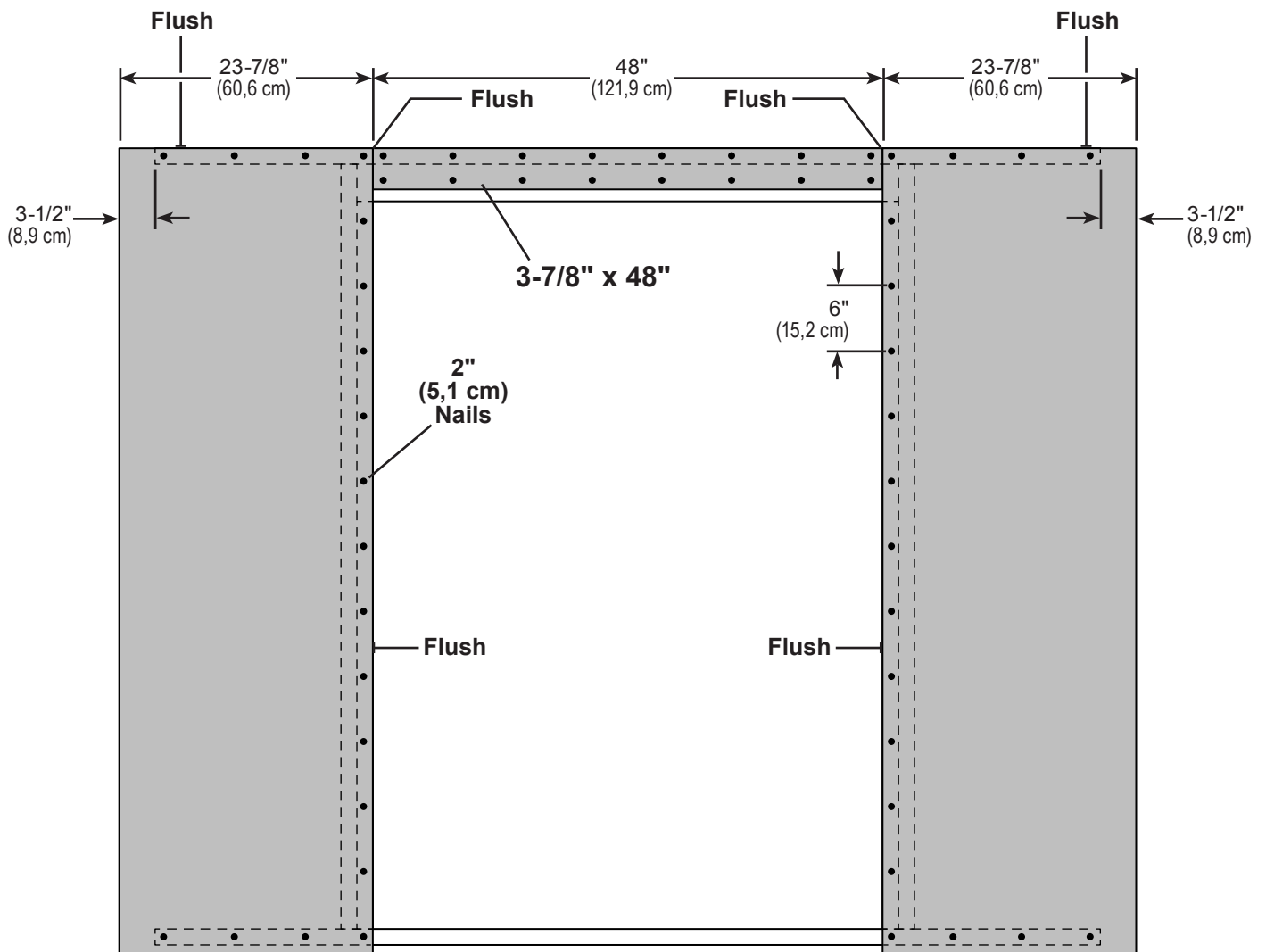

Carefully flip the front wall over.



Your 8' wall with door is now assembled.

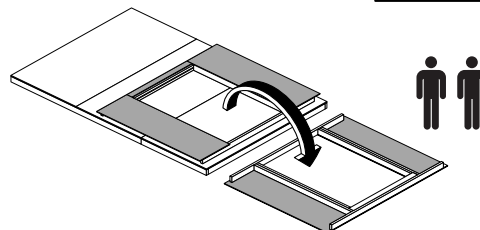

If your door is on the 8' wall, go to page 19 to continue assembly.

12' WALL WITH DOOR CENTERED

PARTS REQUIRED:

- x1 **SP**
2 x 4 x 48" (5,1 x 10,2 x 121,9 cm)
- x10 **TM**
2 x 4 x 72" (5,1 x 10,2 x 182,9 cm)
- x2 **YFA**
2 x 4 x 68-1/2" (5,1 x 10,2 x 174 cm)
- x1 **TP**
2 x 4 x 96" (5,1 x 10,2 x 243,8 cm)

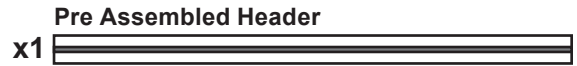
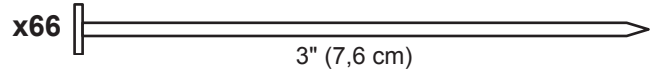

✓ BEGIN

- 1** Orient parts on edge on floor as shown. Measure and mark.
Secure parts with (2) 3" nails at each mark and (4) 3" nails at seams.



HINT:
For easier nailing
stand on frame.

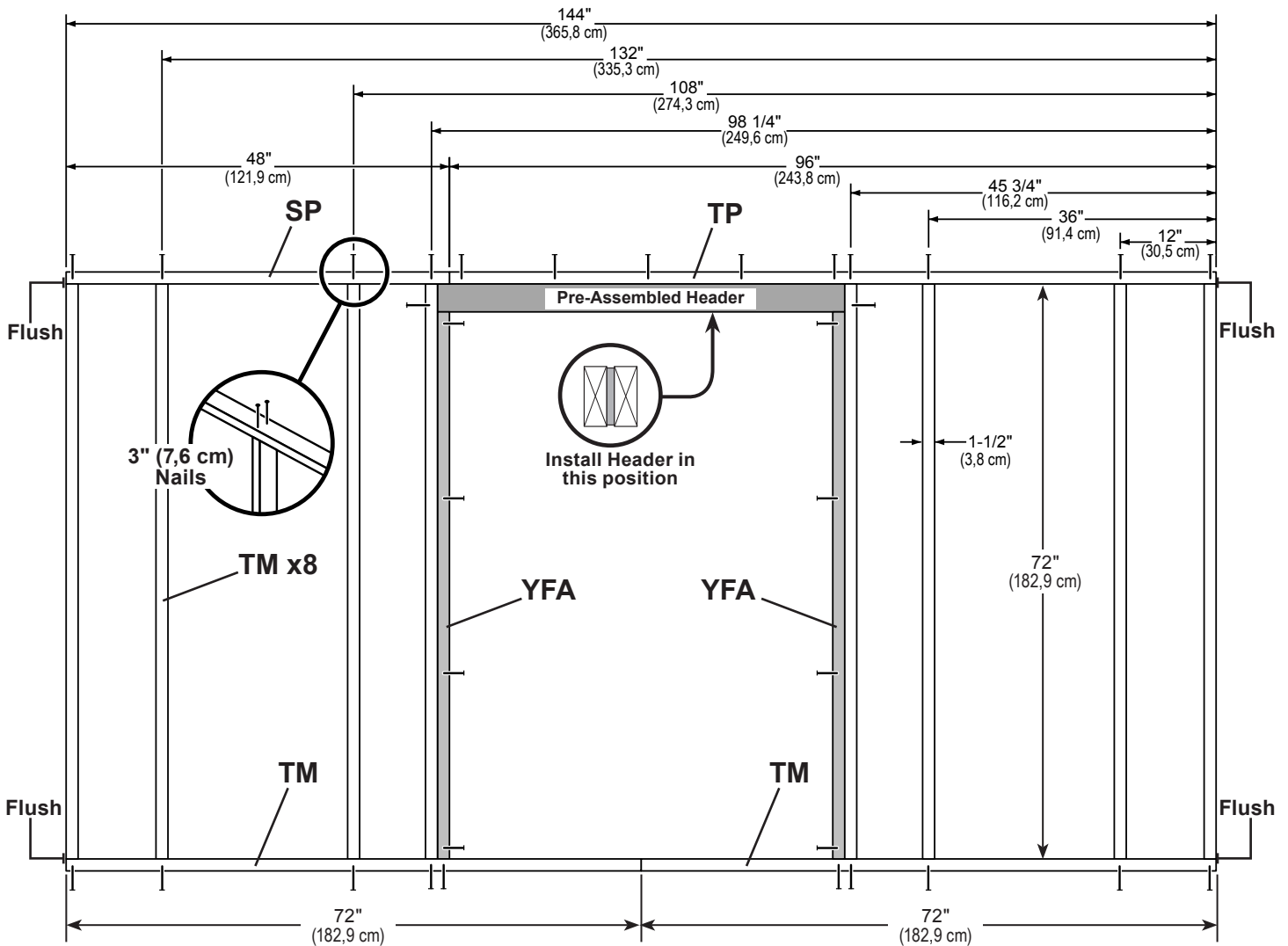
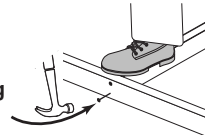



12' WALL WITH DOOR CENTERED

PARTS REQUIRED:

x1 **OO** Temporary Brace
69" (75,3 cm) Door Stiffener

x1 
3/8 x 3-7/8 x 48"
(1 x 9,8 x 121,9 cm)

x2 
3/8 x 48 x 76"
(1 x 121,9 x 193 cm)

x2 
3" (7,6 cm)

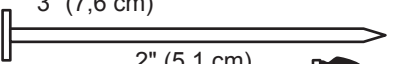
x120 
2" (5,1 cm)



Install all panels with the primed side facing up.

- 2** Place (2) 48" x 76" panels and 3-7/8" x 48" panel on wall frame as shown. Flush all panels to top plate and flush the 48" x 76" panels along edge of door frame.
- 3** Maintain a 48" (121,9 cm) door opening using **OO** as a temporary brace. Secure panels with 2" nails spaced 6" apart on edges and 12" inside panels. Secure **OO** with (2) 3" screws.

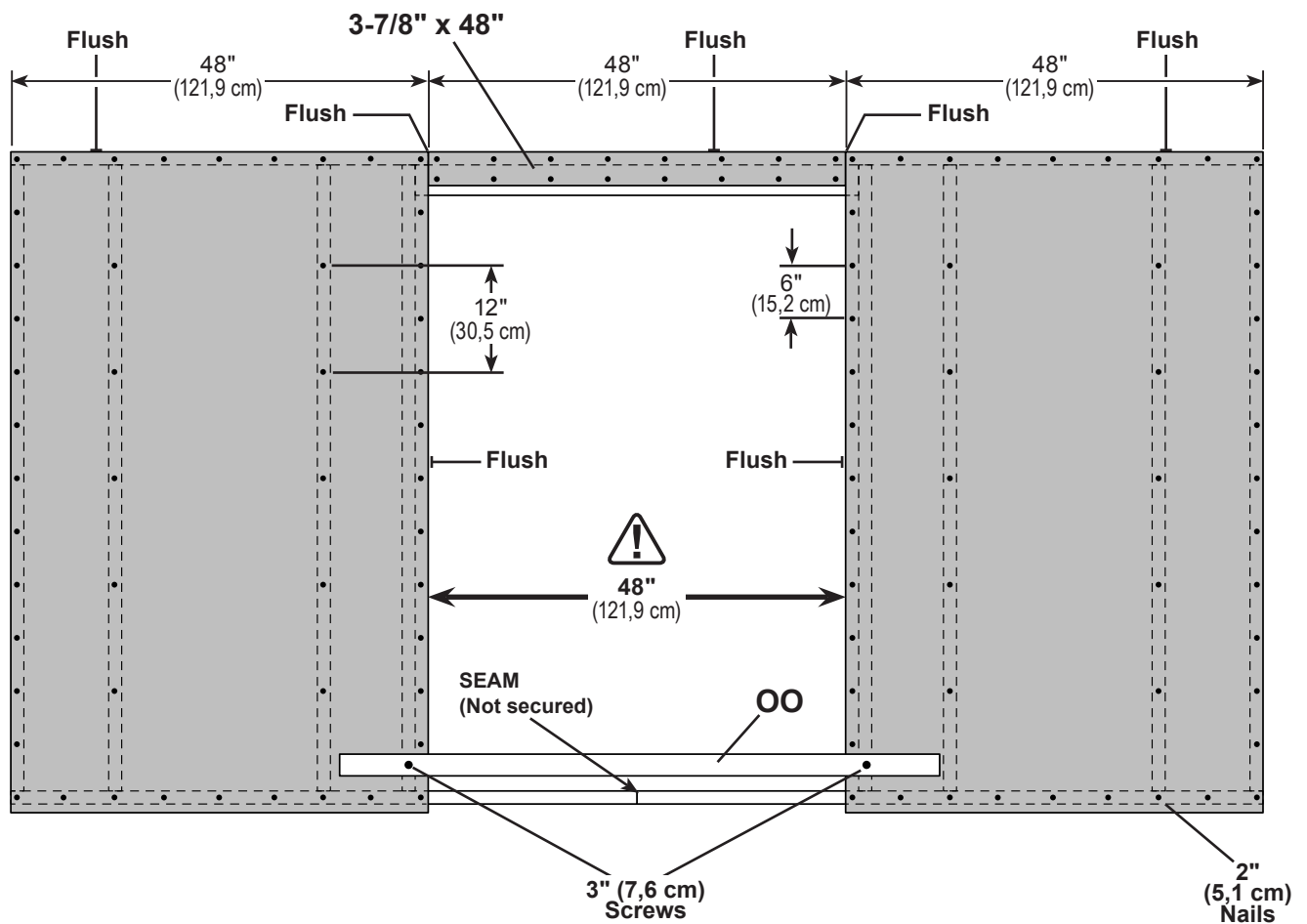

Carefully flip the 12' wall over.



FINISH

Your 12' wall with door is now assembled.

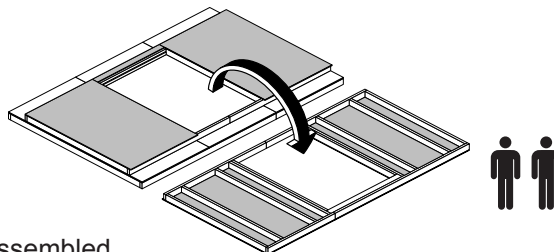

If your door is on the 12' wall, go to page 19 to continue assembly.

12' WALL WITH DOOR OFFSET

PARTS REQUIRED:

- x1 **SP**
2 x 4 x 48" (5,1 x 10,2 x 121,9 cm)
- x8 **TM**
2 x 4 x 72" (5,1 x 10,2 x 182,9 cm)
- x2 **YFA**
2 x 4 x 68-1/2" (5,1 x 10,2 x 174 cm)
- x1 **TP**
2 x 4 x 96" (5,1 x 10,2 x 243,8 cm)

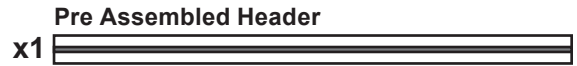
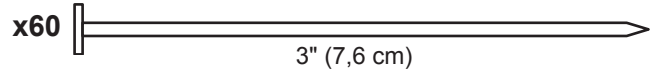

✓ BEGIN

- 1 Orient parts on edge on floor as shown. Measure and mark.
Secure parts with (2) 3" nails at each mark.



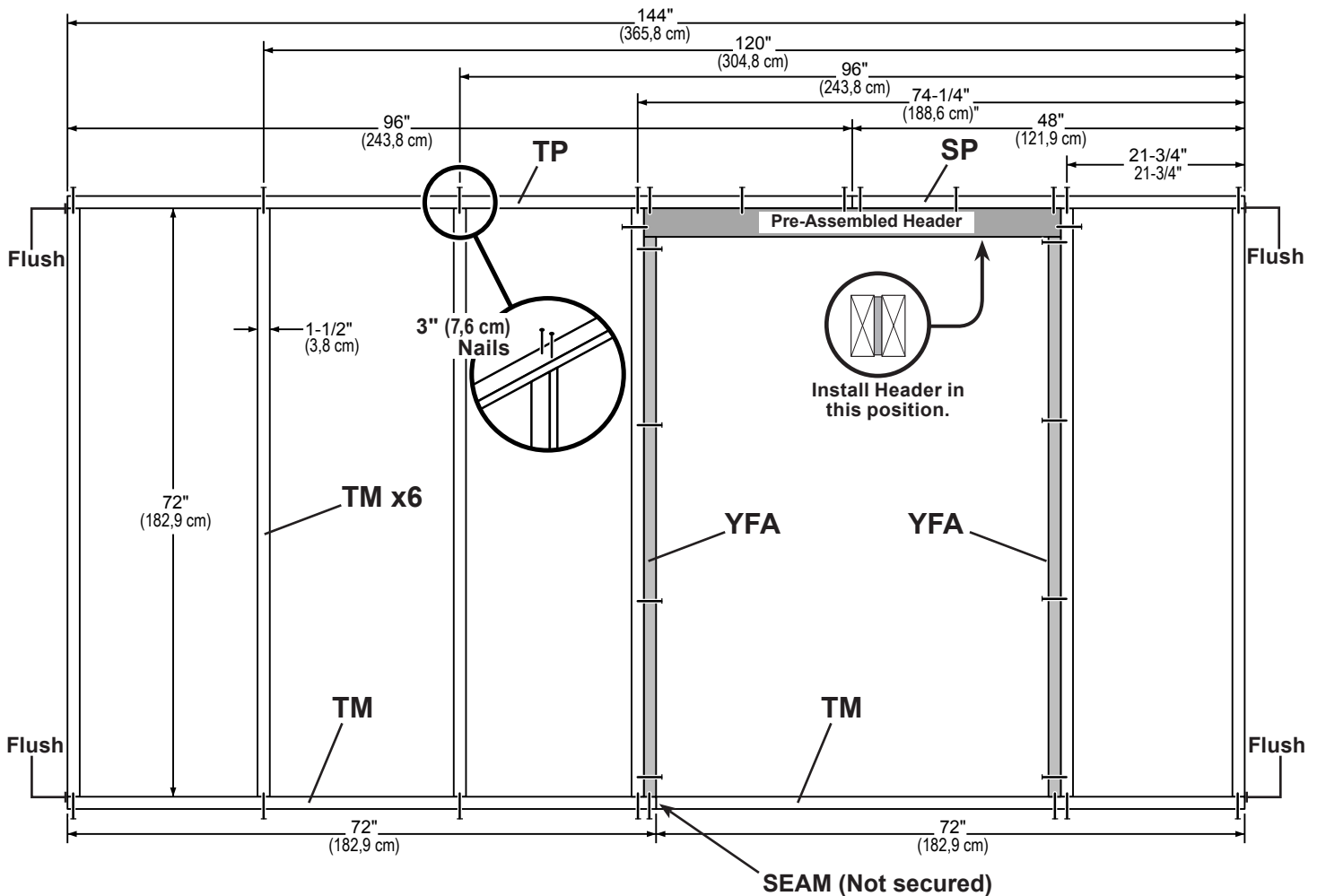
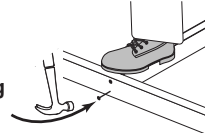

HINT:
For easier nailing
stand on frame.



You may choose to have the door offset to the left side of the 12' wall.

12' WALL WITH DOOR OFFSET

PARTS REQUIRED:

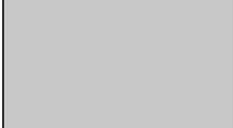
- x1  3/8 x 3-7/8 x 48"
(1 x 9,8 x 121,9 cm)
- x1  **OO** Temporary Brace
69" (75,3 cm) Door Stiffener
- x2  3/8 x 23-7/8 x 76"
(1 x 60,6 x 193 cm)
- x1  3/8 x 48 x 76"
(1 x 121,9 x 193 cm)

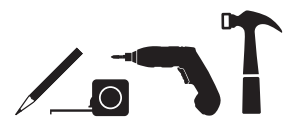
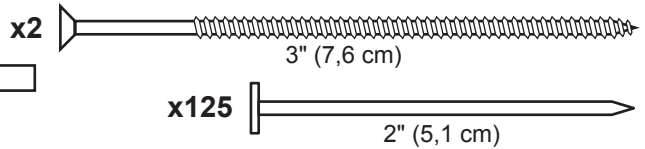

Install all panels with the primed side facing up.

- 2** Place (2) 23-7/8" x 76" panels and 3-7/8" x 48" panel on wall frame as shown. Flush all panels to top plate and flush the 23-7/8" x 76" panels along edge of door frame.
- 3** Maintain a 48" (121,9 cm) door opening using **OO** as a temporary brace. Secure panels using 2" nails 6" apart. Secure **OO** with (2) 3" screws.
- 4** Install 48 x 76" panel flush to installed panel. Secure panel with 2" nails spaced 6" apart on edges and 12" inside panel

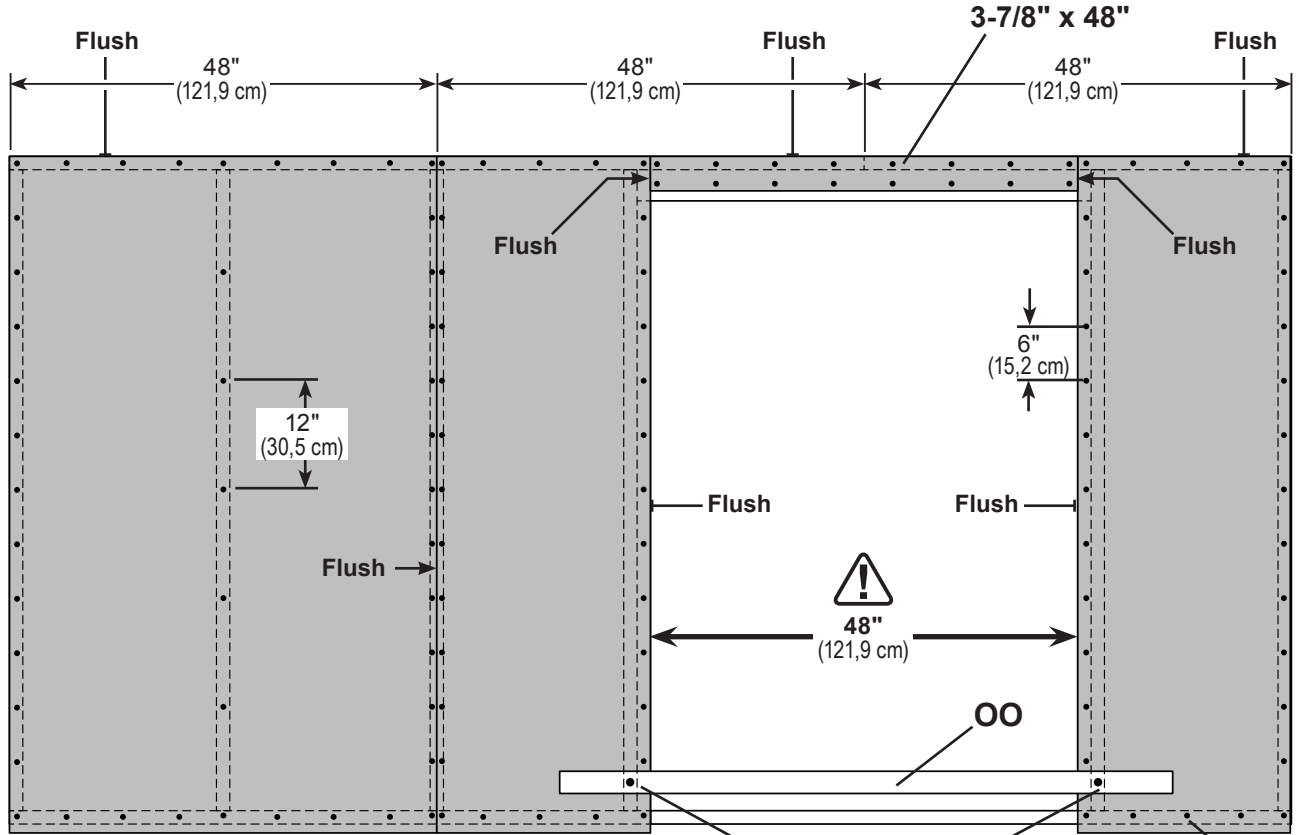

Carefully flip the 12' wall over.



Your 12' wall with door is now assembled.

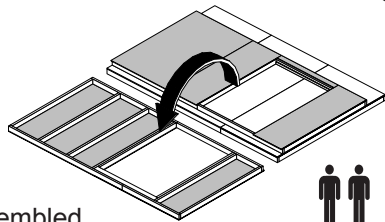

If your door is on the 12' wall, go to page 19 to continue assembly.

12' WALL - NO DOOR

PARTS REQUIRED:

x1 **SP**
2 x 4 x 48" (5,1 x 10,2 x 121,9 cm)

x7 **TM**
2 x 4 x 72" (5,1 x 10,2 x 182,9 cm)

x2 **TP**
2 x 4 x 96" (5,1 x 10,2 x 243,8 cm)

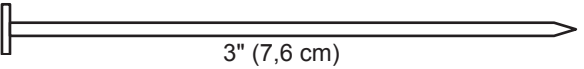
x32  3" (7,6 cm)

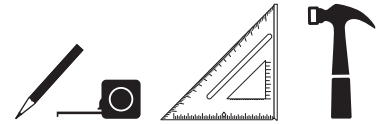

If your door is on the gable wall you will build (2) identical 12' walls.

If your door is on the 12' wall you will build (1) 12' wall.

✓ BEGIN

- 1 Orient parts on edge on floor as shown. Measure and mark.
Secure parts with (2) 3" nails at each mark and (4) 3" nails at seams.



HINT:
For easier nailing
stand on frame.

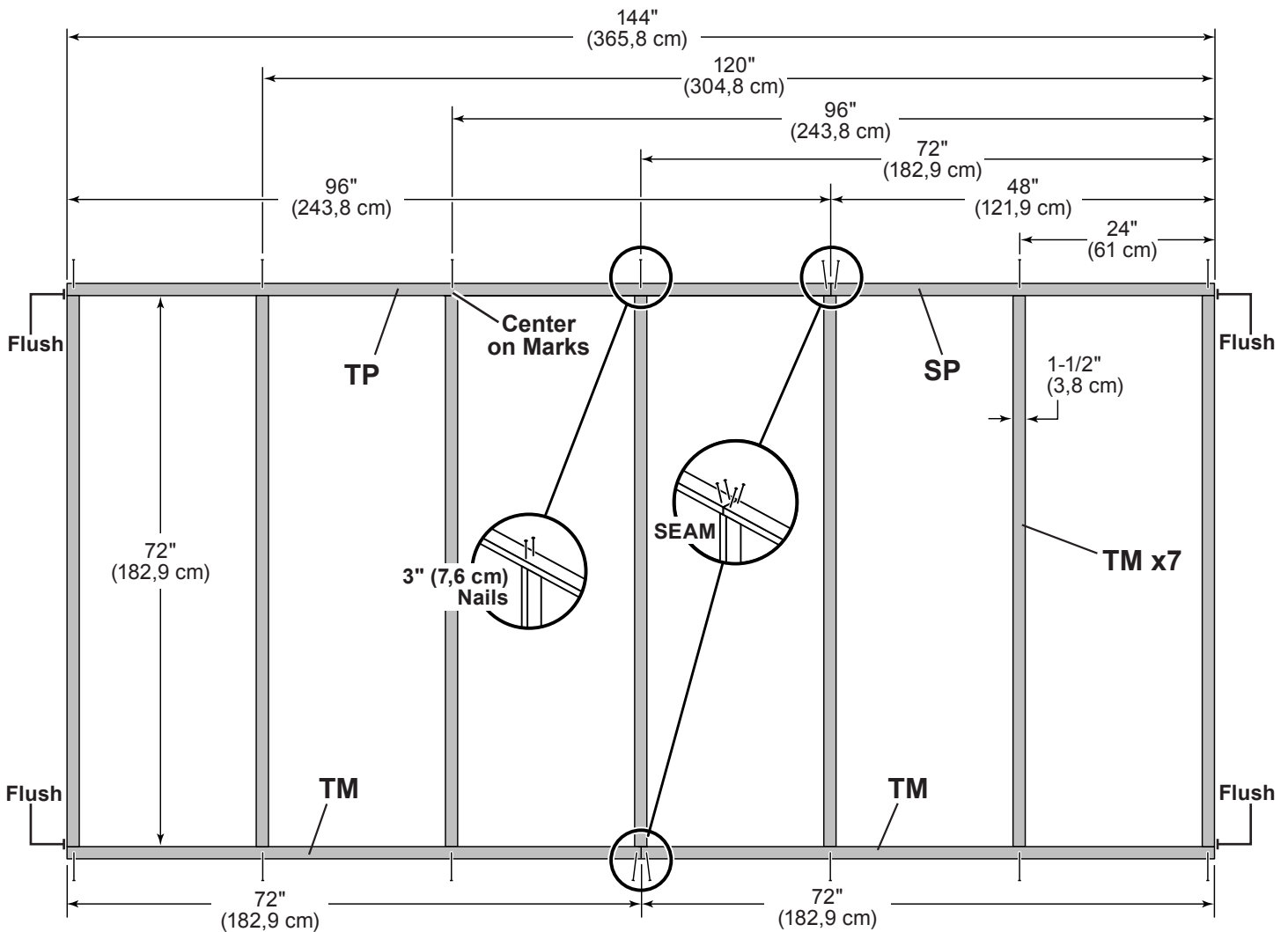
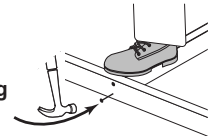

12' WALL - NO DOOR

PARTS REQUIRED:

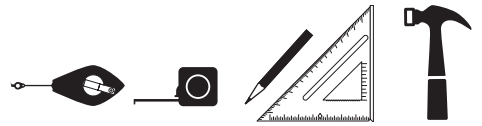
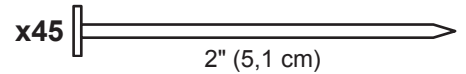
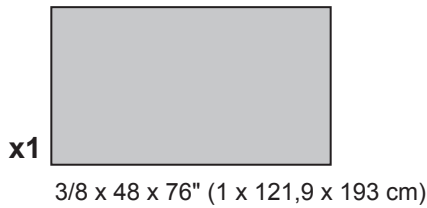

Install all panels with the primed side facing up.



Ensure your wall frame is square by installing one panel and squaring frame.

2

Place (1) 48" x 76" panel on wall frame as shown. Use the **GAA** gauge block to mark the 3/4" measurement on the wall stud. Secure panel with (2) 2" nails in the corners (**Fig. A**).

3

Move to the opposite end. Using the long edge of the panel as a lever move the panel side-to-side until you have a 3/4" measurement on the wall stud. Secure corners with (2) 2" nails (**Fig. B**).

Secure the panel with 2" nails spaced 6" apart on edges and 12" apart inside panel.

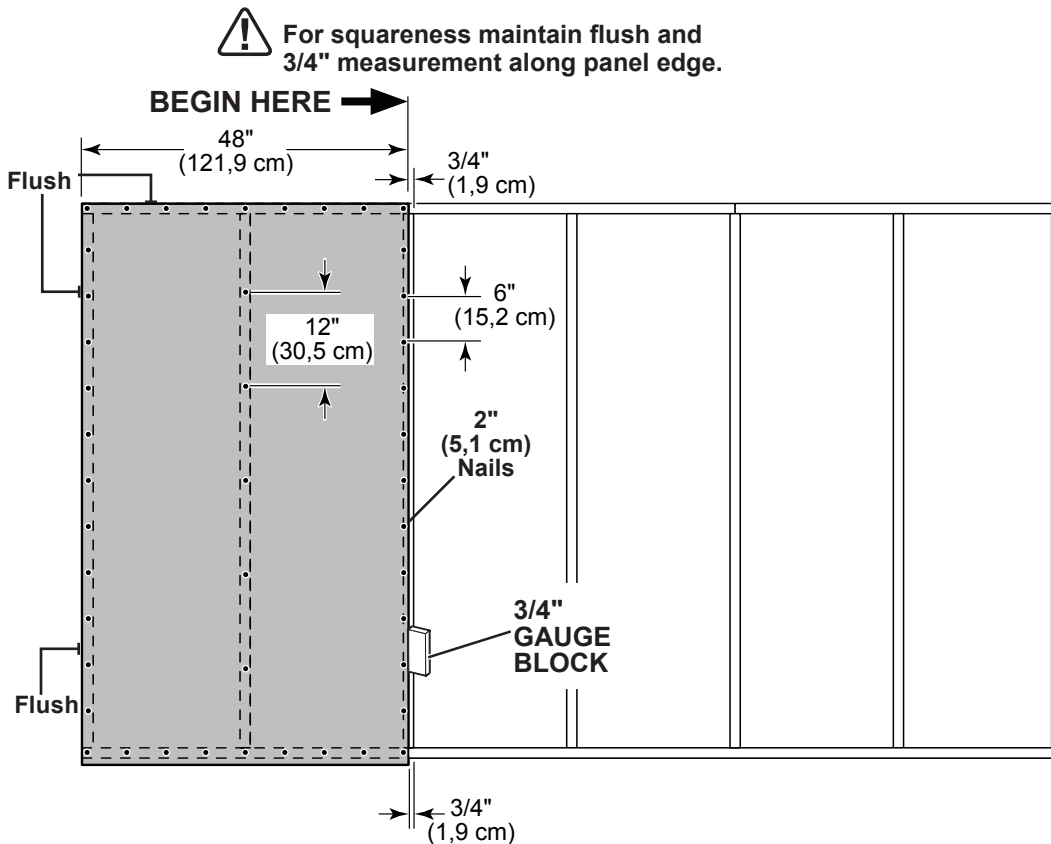

2 Nails

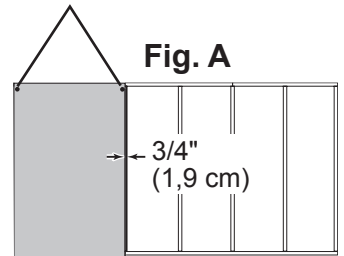
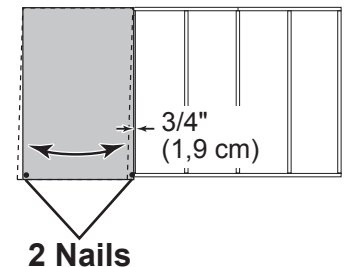
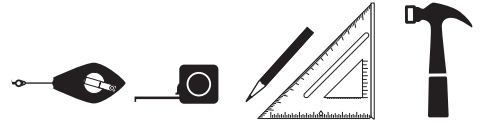
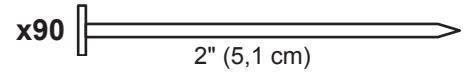
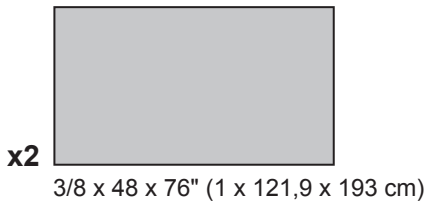

Fig. B



12' WALL - NO DOOR

PARTS REQUIRED:



- 4** Install (2) **48" x 76"** panels flush to installed panels and flush to top of frame.
Secure the panels with 2" nails spaced 6" apart on edges and 12" apart inside panel.

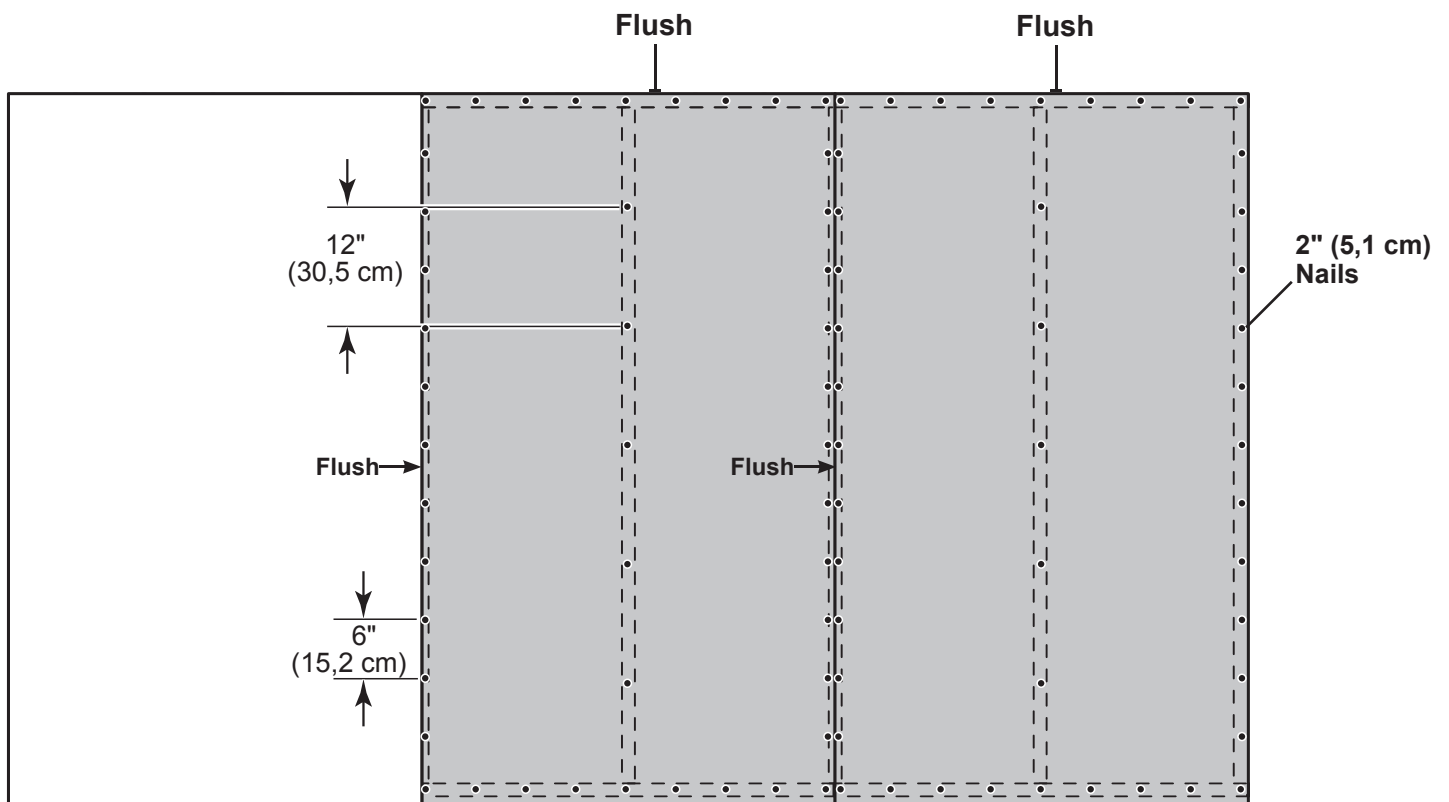

Carefully flip your eave wall over.

Repeat STEPS 1 - 4 to build a second 12' wall if your door is on the 8' gable side.

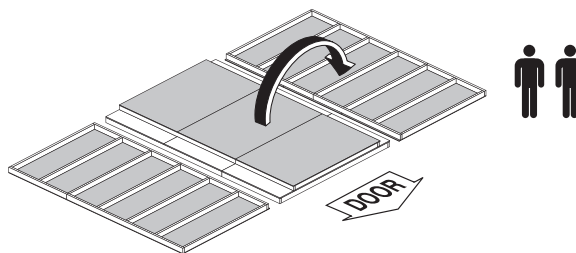

You have finished building your eave wall(s).

"A" GABLE WALL

PARTS REQUIRED:

x3 **TM**
2 x 4 x 72" (5,1 x 10,2 x 182,9 cm)

x2 **SZ**
2 x 4 x 89" (5,1 x 10,2 x 226,1 cm)

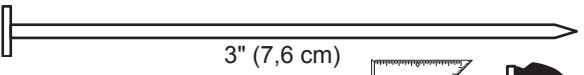
x12  3" (7,6 cm)

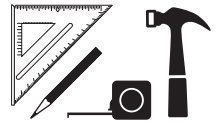

IF YOUR DOOR IS ON THE GABLE WALL YOU WILL BUILD 1 "A" GABLE WALL.

IF YOUR DOOR IS CENTERED ON THE 12' EAVE WALL YOU WILL BUILD 1 "A" and 1 "B" GABLE WALL (P. 24).

IF YOUR DOOR IS OFFSET ON THE 12' EAVE WALL YOU WILL BUILD 2 IDENTICAL "A" GABLE WALLS.

BEGIN

- 1** Orient parts on edge on floor as shown. Measure and mark.
Secure parts with (2) 3" nails at each mark.

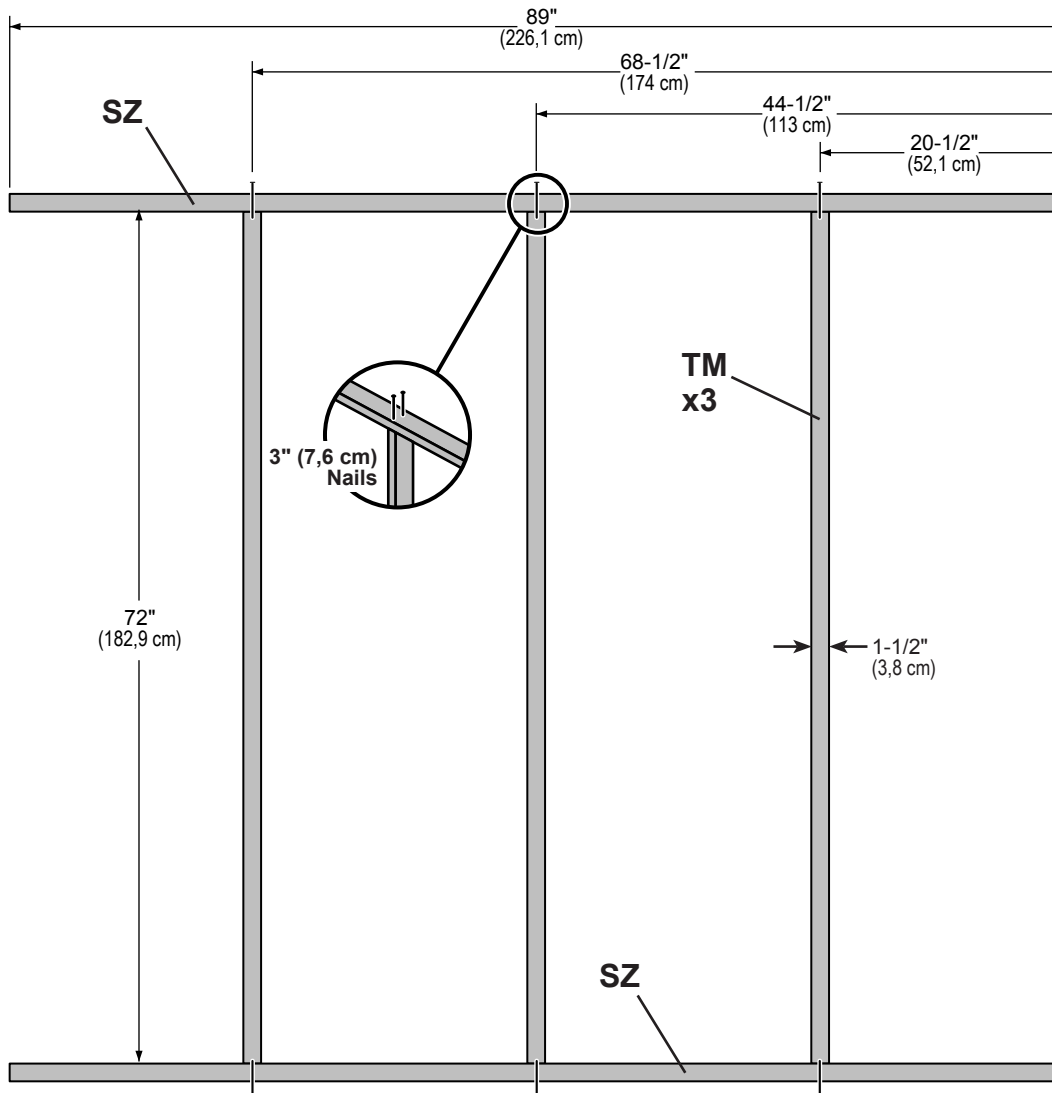

"A" GABLE WALL

PARTS REQUIRED:

GAA
3/4" GAUGE
BLOCK

x2



3/8 x 48 x 76"
(1 x 121,9 x 193 cm)

x64

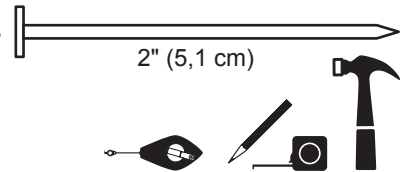

Install all panels with the primed side facing up.

- Install (2) 48" x 76" panels on frame flush at top. Use the gauge block **GAA** to maintain a 3/4" measurement on the wall stud. Panels will overlap the frame approximately 3-1/2" (8,9 cm) at each side. Secure panels with 2" nails spaced 6" apart along edges and 12" inside panel.

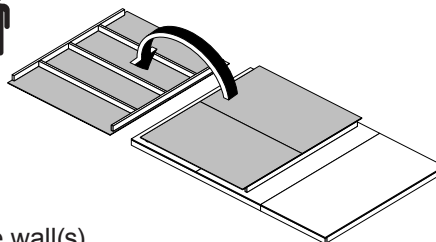
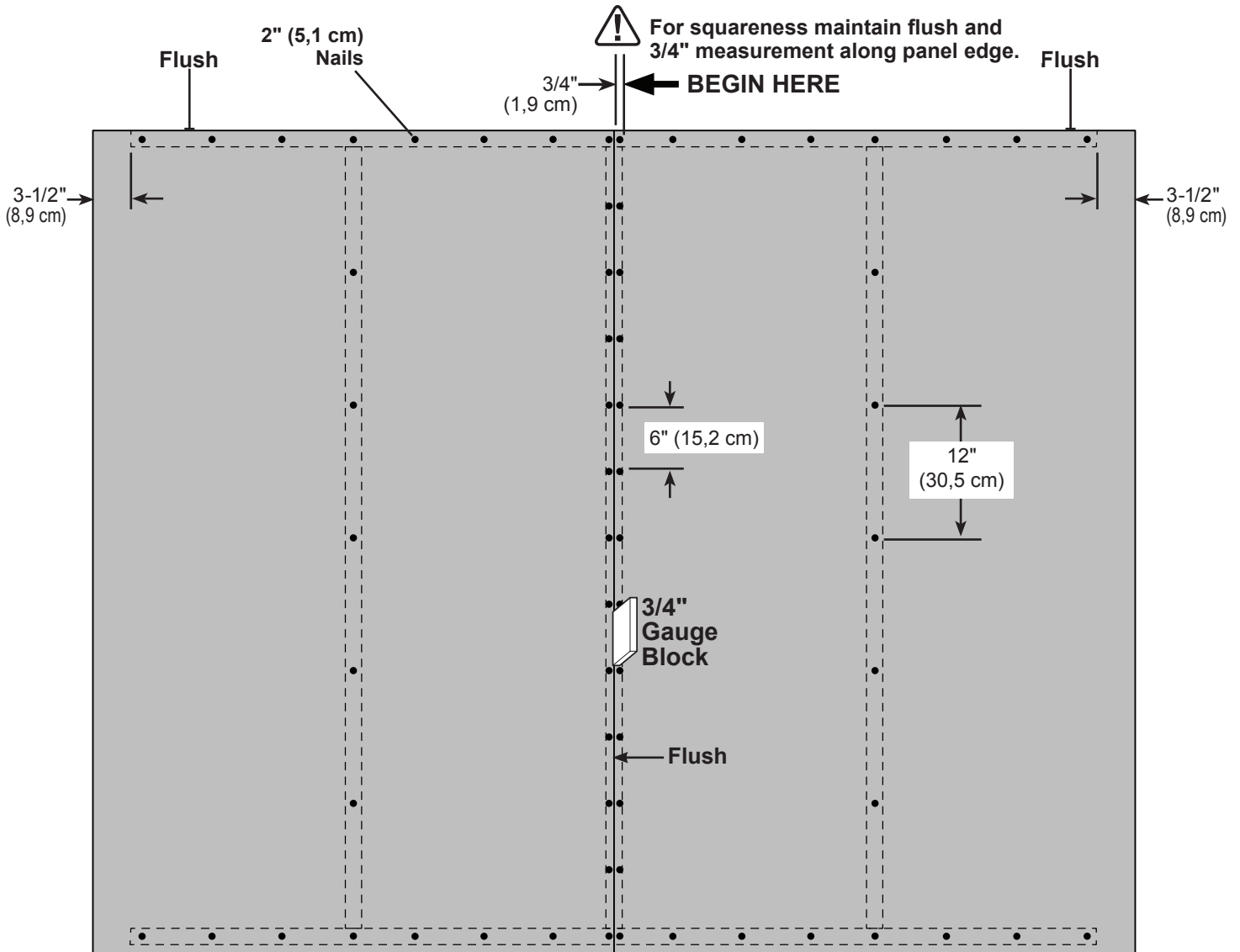

Carefully flip the gable wall over.



You have finished building your "A" gable wall(s).

"B" GABLE WALL

PARTS REQUIRED:

x3 **TM**
2 x 4 x 72" (5,1 x 10,2 x 182,9 cm)

x2 **SZ**
2 x 4 x 89" (5,1 x 10,2 x 226,1 cm)

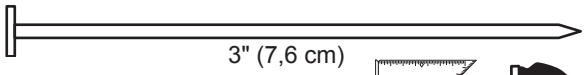
x12  3" (7,6 cm)

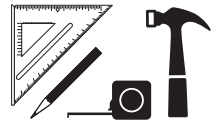

✓ **BEGIN**

- 1 Orient parts on edge on floor as shown. Measure and mark.
Secure parts with (2) 3" nails at each mark.

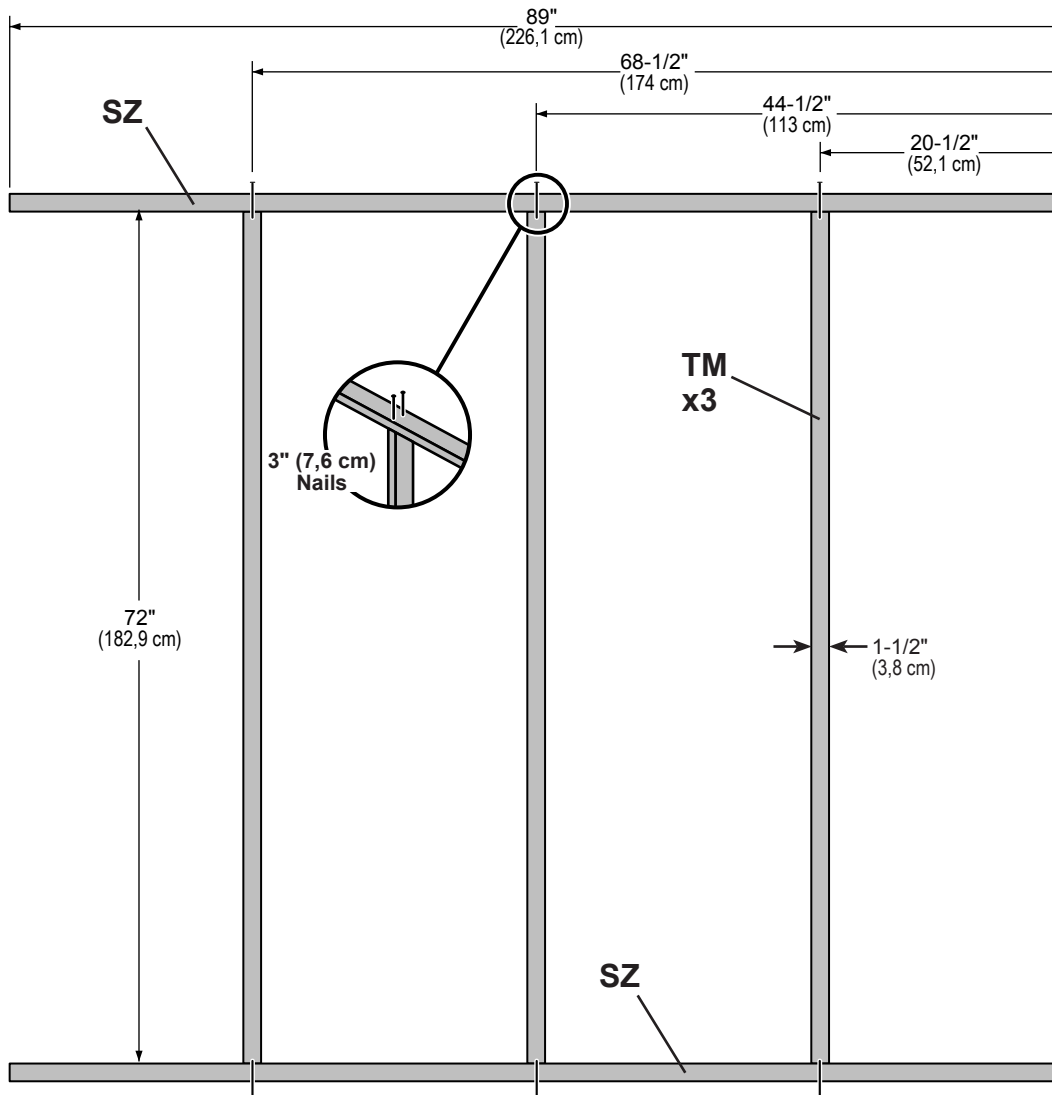

"B" GABLE WALL

PARTS REQUIRED:

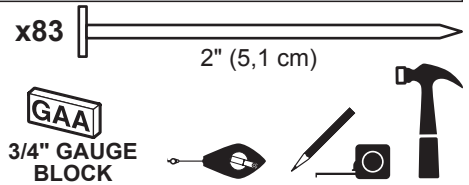
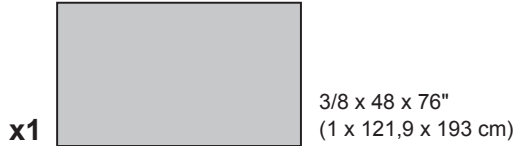
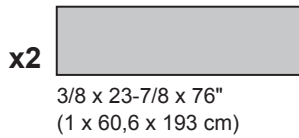

Install all panels with the primed side facing up.

- Place (1) 48" x 76" and (2) 23-7/8" x 76" panels on frame flush at top. Install 48" x 76" panel first. Use the gauge block **GAA** to maintain 3/4" measurement on the wall stud. Panels will overlap the frame approximately 3-1/2" (8.9 cm) at each side. Secure panels with 2" nails spaced 6" apart along edges and 12" inside panel.

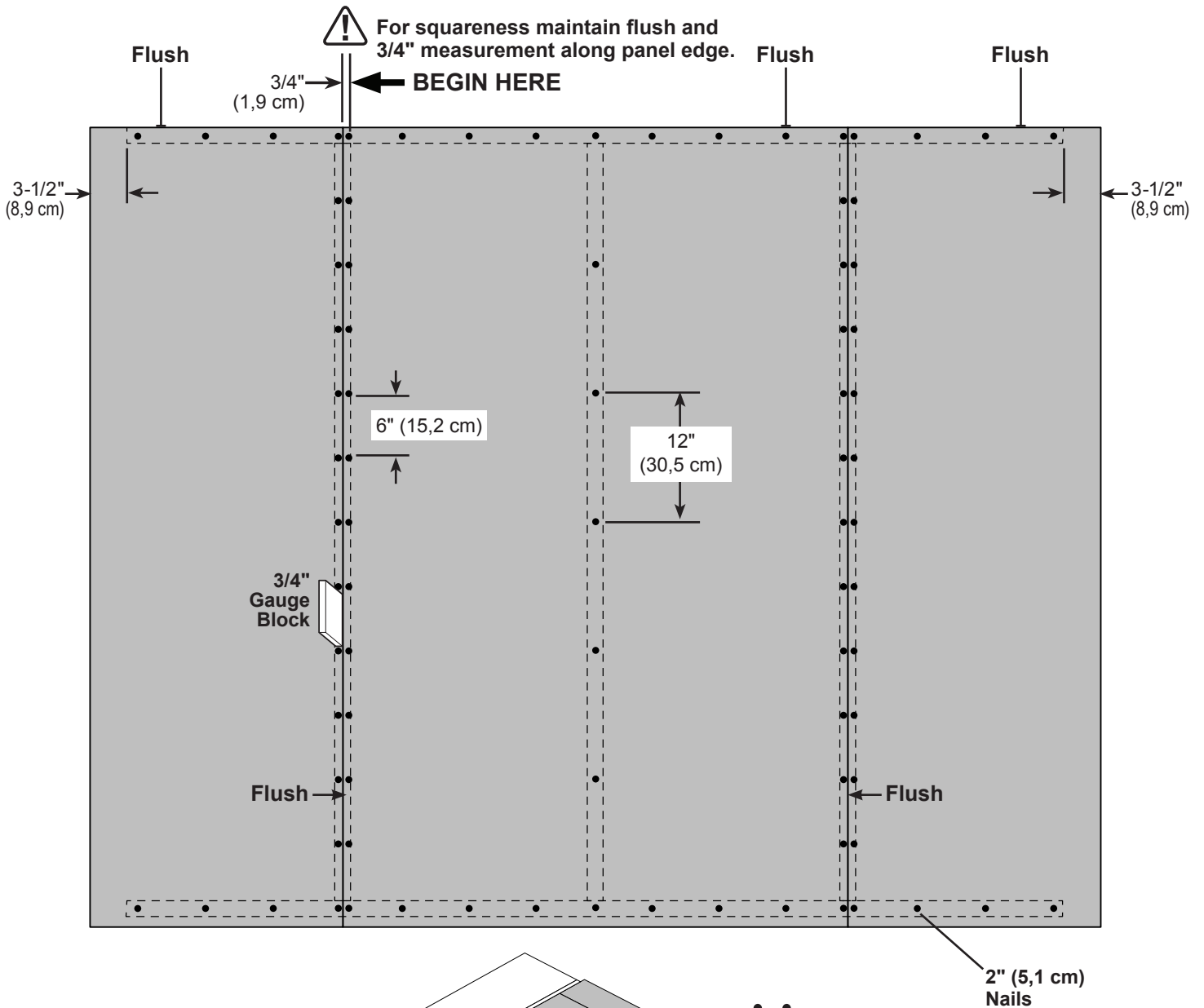

Carefully flip the gable wall over.

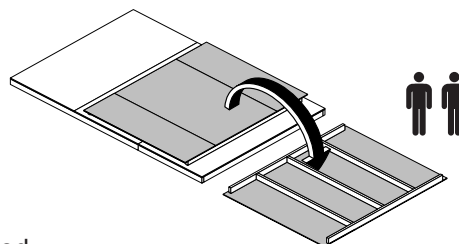

FINISH

Your "B" gable wall is now assembled.



STANDING YOUR WALLS

The following steps show how to stand and secure your walls.
These instructions are by default with the door on the gable wall.

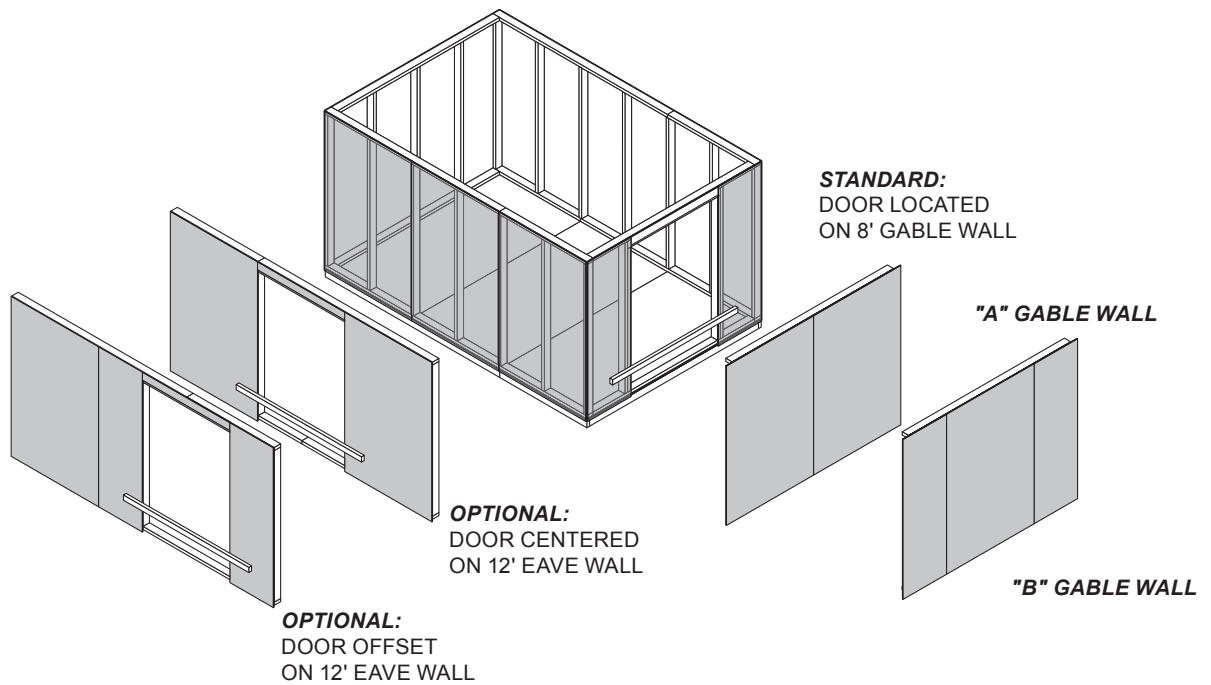

12' WALL INSTALLATION

PARTS REQUIRED:

x1 **OO**
69" (175,3 cm) Door Stiffener



x12 3" (7,6 cm)
x2 3" (7,6 cm)
x27 2" (5,1 cm)

✓ **BEGIN**

- Center 12' wall on the 144" (365,8 cm) floor dimension.
1" (2,5 cm) overlap is to the bottom.

Use **OO** as a temporary brace.
Secure with (2) 3" screws.

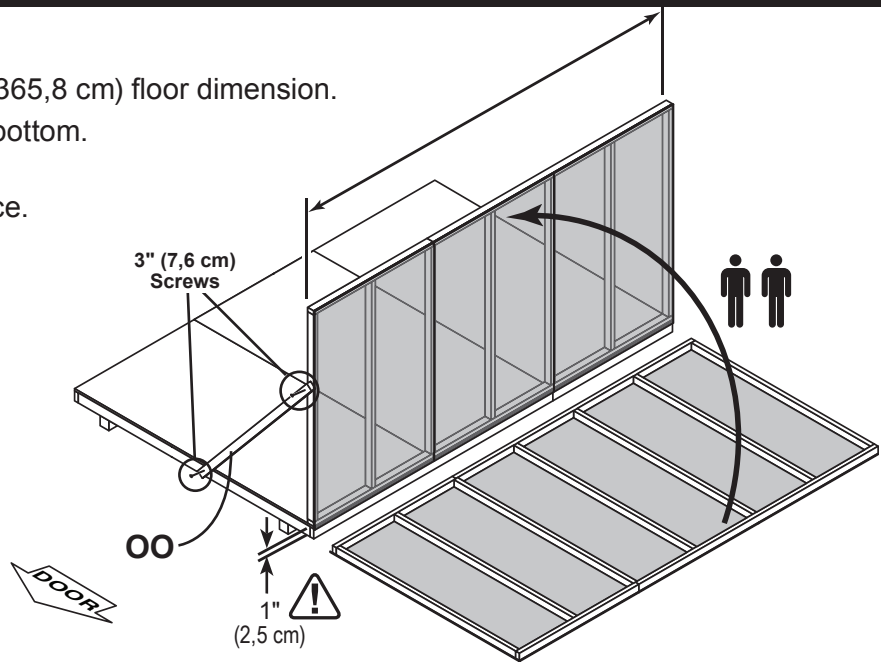

- Secure lower edge of panel to floor frame with 2" nails spaced 6" apart.
Angle nails into floor frame (**Fig. A**).

- Secure wall bottom plates to floor with 3" nails (**Fig. A**).

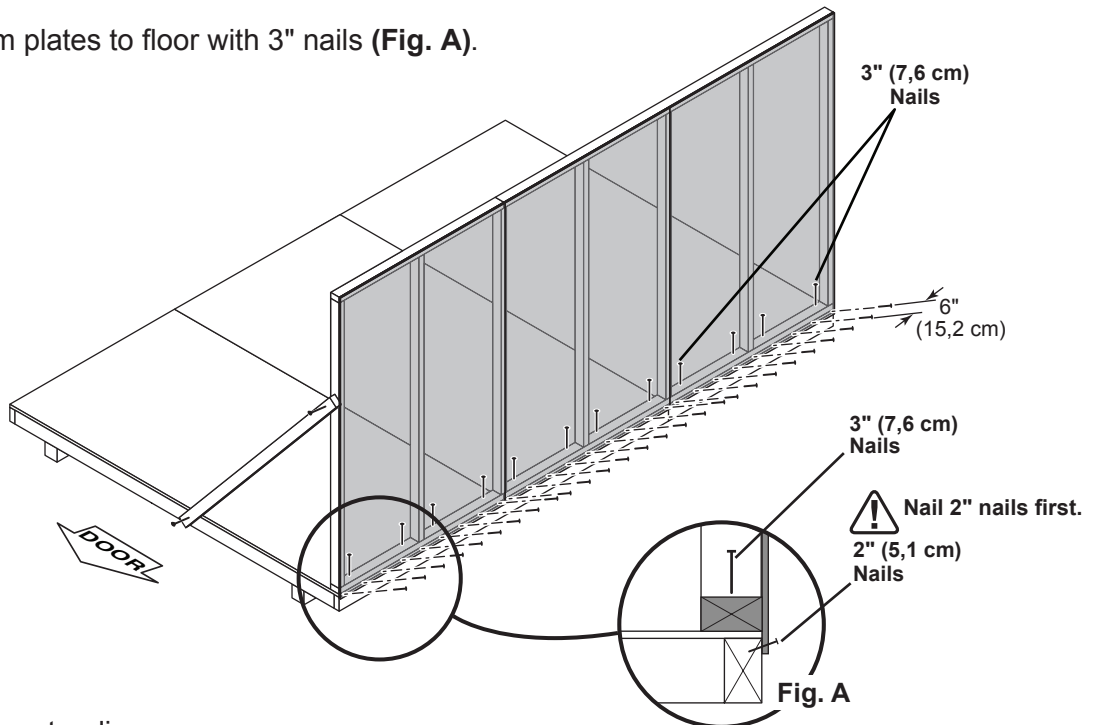

Your 12' wall is now standing.

GABLE WALL INSTALLATION

PARTS REQUIRED

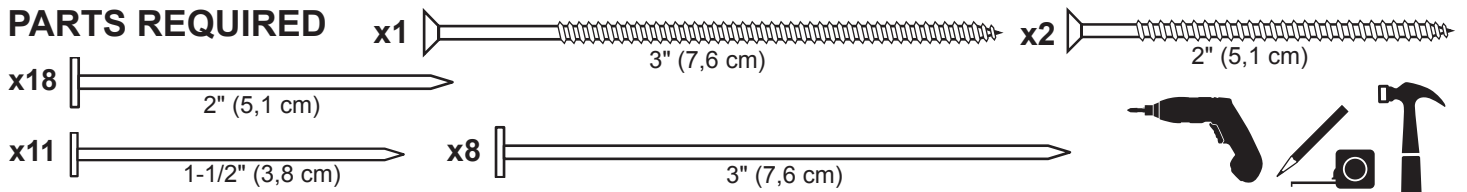

✓ BEGIN

1 Place gable wall centered on floor.

Secure wall with one 2" screw into 12' wall bottom plate (**Fig. A**) and top plate (**Fig. B**).

Secure wall to bottom plate first.

⚠ **ENSURE PANEL CORNERS ARE FLUSH.**

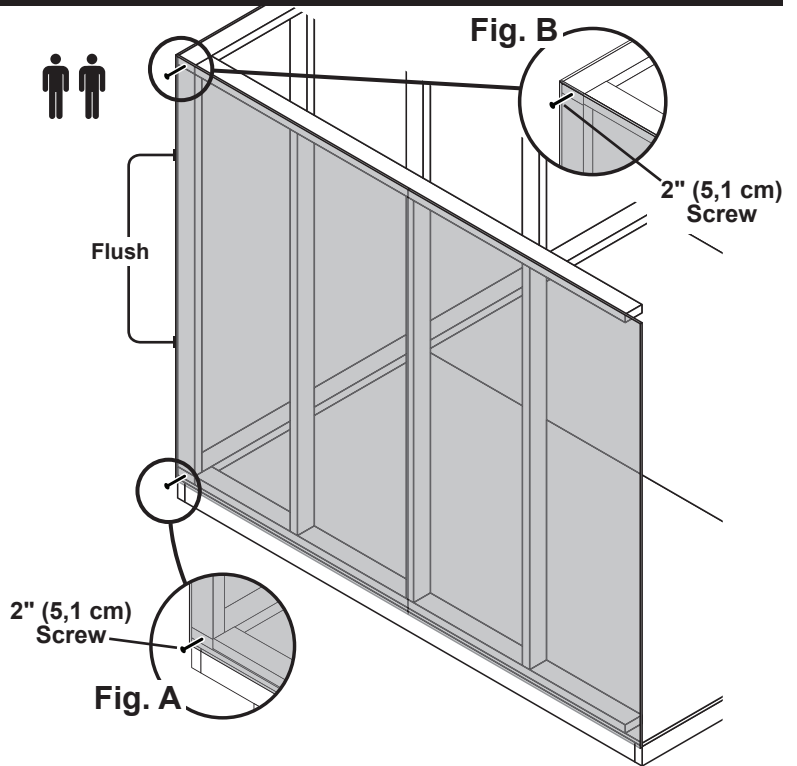

2 Nail lower edge of panels to floor with 2" nails spaced 6" apart. Angle nails into floor frame (**Fig. C**).

Nail panels to back wall stud with 1-1/2" nails.

3 Secure wall top plate with (1) 3" screw toe-screwed at the corner at an angle as shown in (**Fig. D**).



FINISH
Your gable wall is now installed.

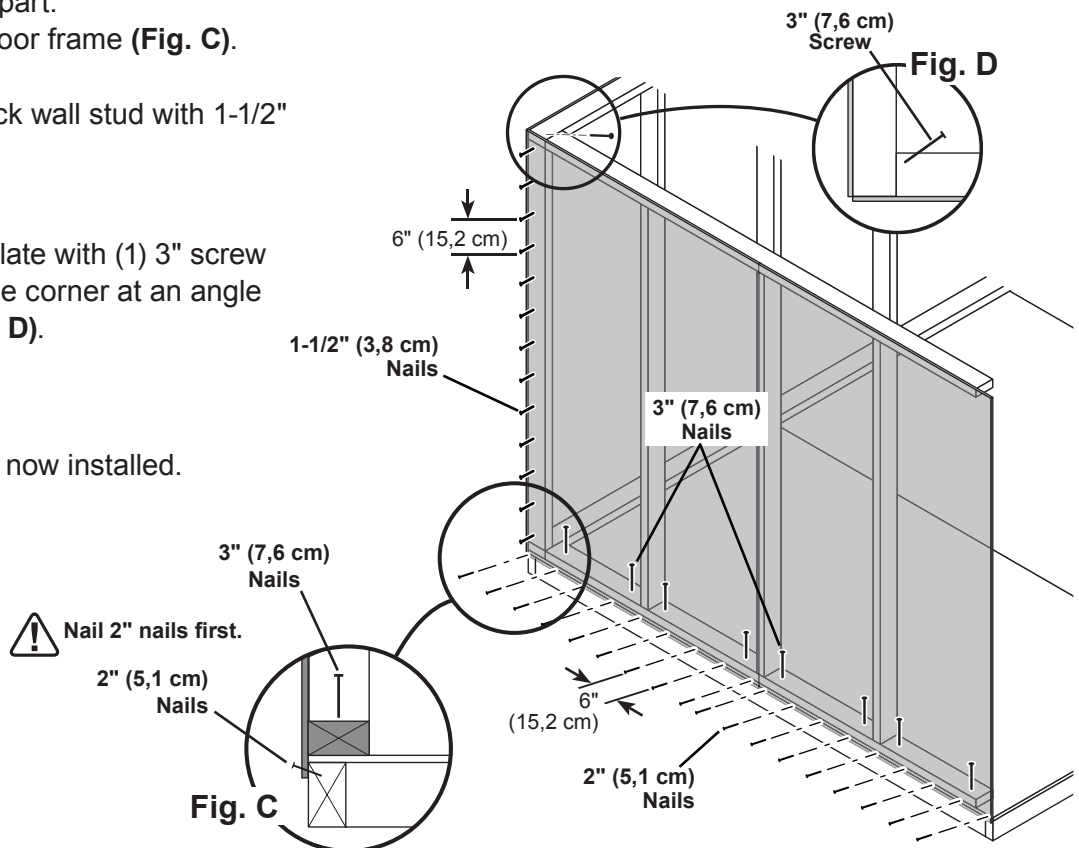

12' WALL INSTALLATION

PARTS REQUIRED:

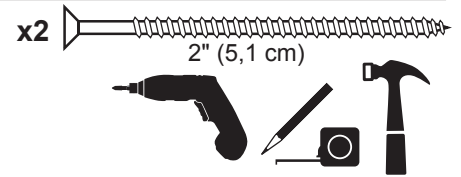

✓ BEGIN

1 Center 12' wall on the 144" (365,8 cm) floor dimension.

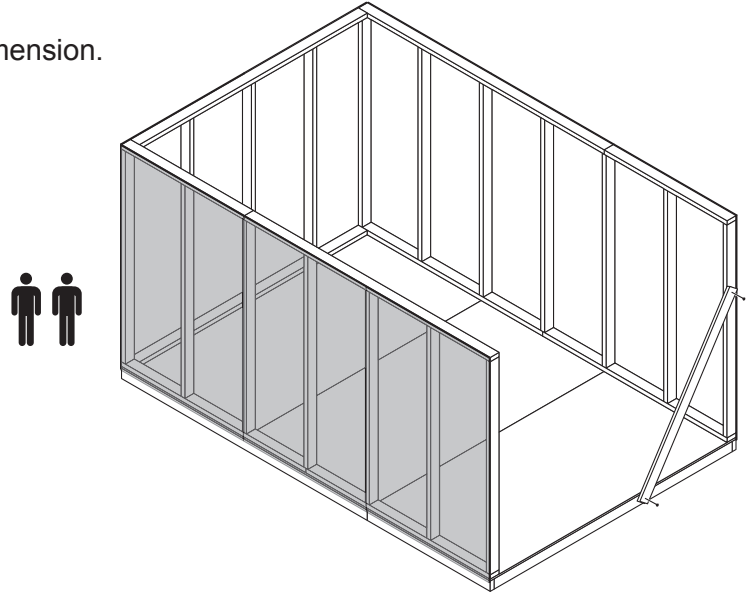
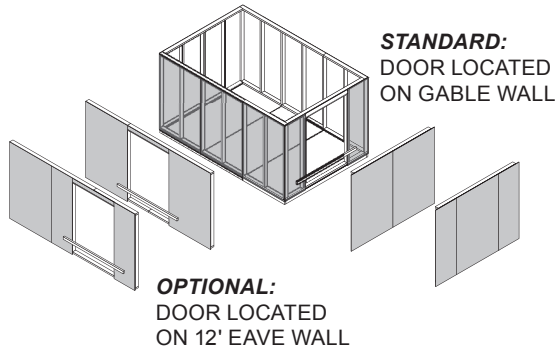

2 Secure wall with (1) 2" screw through gable wall panel into 12' wall bottom and top plates (**Fig. B, Fig. A**).

Secure wall to bottom plate first.

⚠ ENSURE PANEL CORNERS ARE FLUSH.

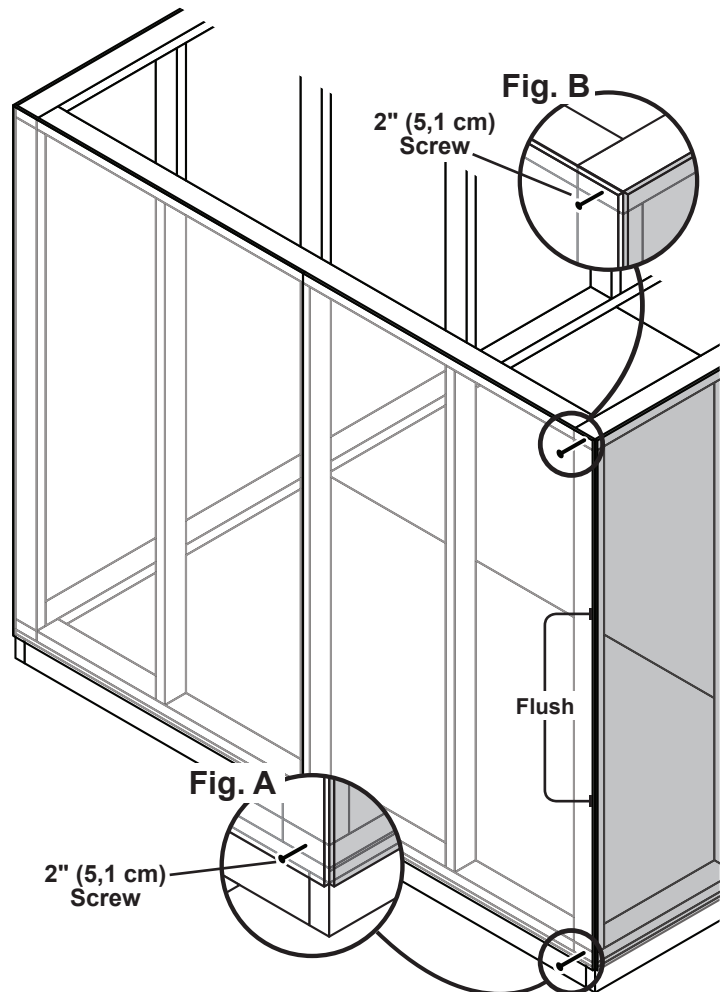

12' WALL INSTALLATION

PARTS REQUIRED:

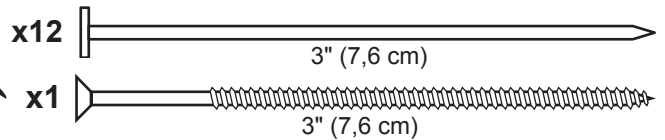
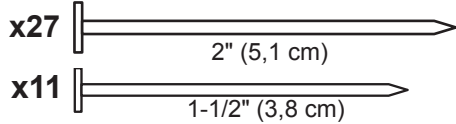

- 3 Nail lower edge of 12' wall panels to floor frame with 2" nails spaced 6" apart. Angle nails into floor frame (**Fig. C**).

Secure wall bottom plates to floor with 3" nails (**Fig. C**).

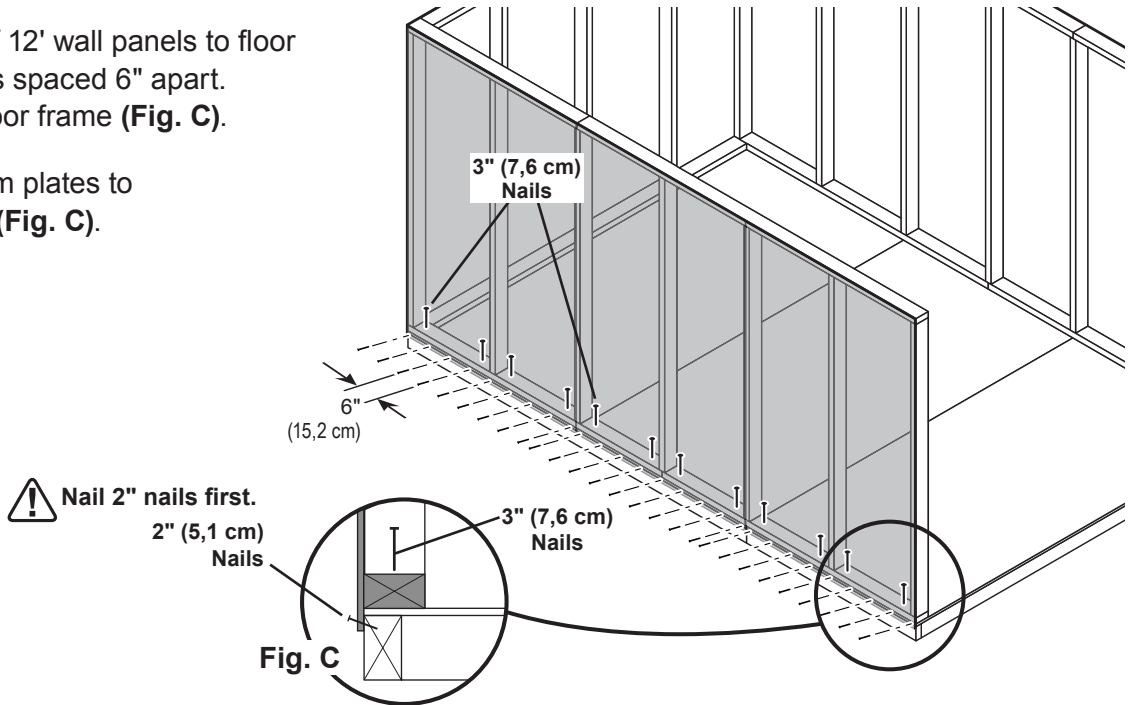

- 4 Nail gable wall panel to 12' wall stud with 1-1/2" nails spaced 6" apart.

- 5 Secure gable wall top plate with (1) 3" screw toe-screwed at the corner at an angle as shown (**Fig. D**).

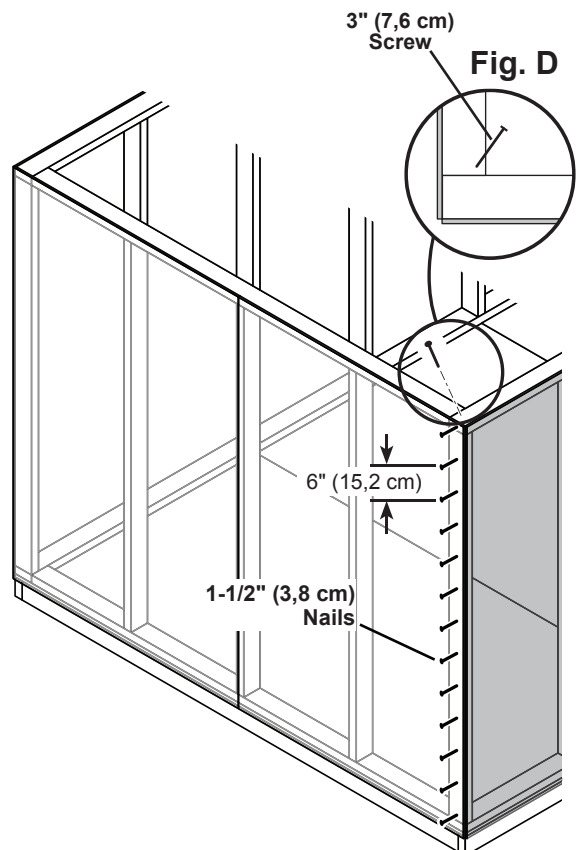

Your 12' wall is now installed.

GABLE WALL INSTALLATION

PARTS REQUIRED

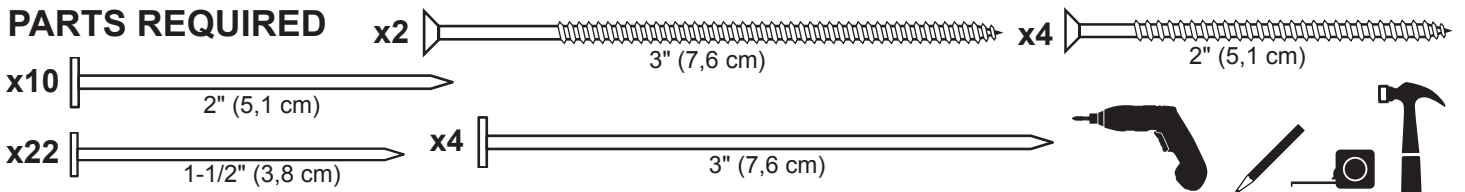

REMOVE TEMPORARY BRACING

✓ **BEGIN**

1 Place 8' wall on floor centered between 12' walls.



Secure wall using 2" screws into top and bottom plates (**Fig. A**, **Fig. B**).

Secure wall to bottom plate first.

⚠ **ENSURE PANEL CORNERS ARE FLUSH.** ⚠

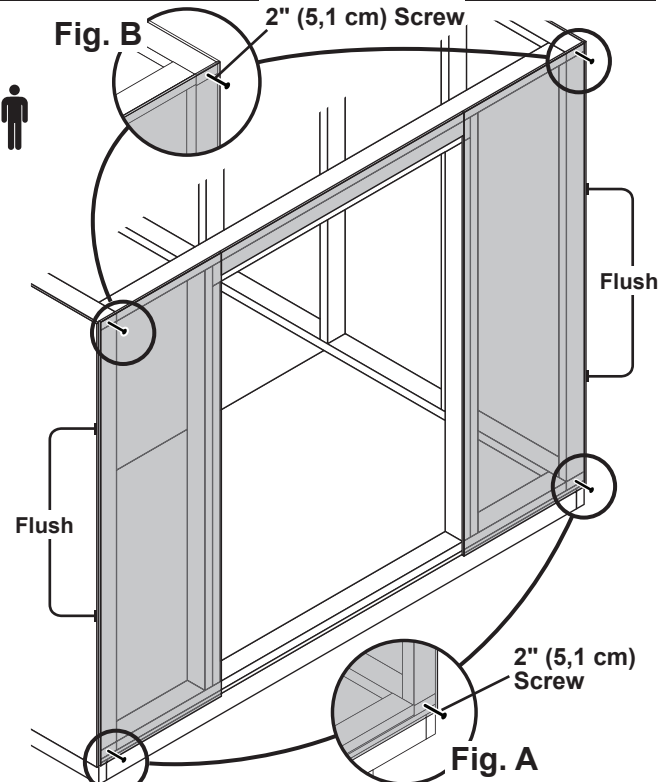
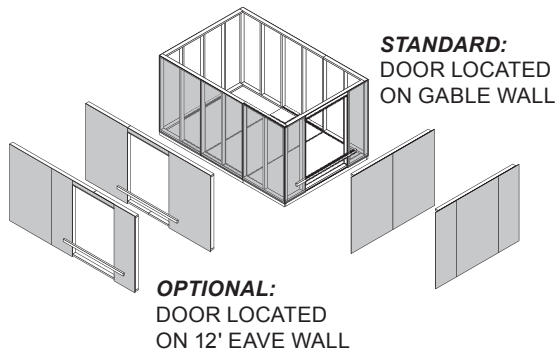

2 Nail lower edge of panels to floor with 2" nails spaced 6" apart. Angle nails into floor frame (**Fig. C**).

Nail panels to both 12' wall studs with 1-1/2" nails.

3 Secure 8' wall top plates with 3" screws toe-screwed at each corner at an angle as shown in (**Fig. D**).

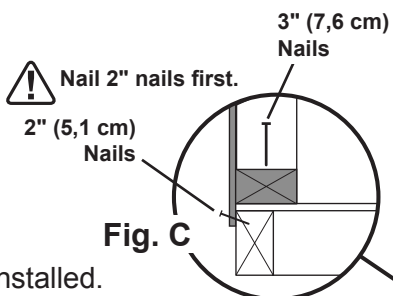
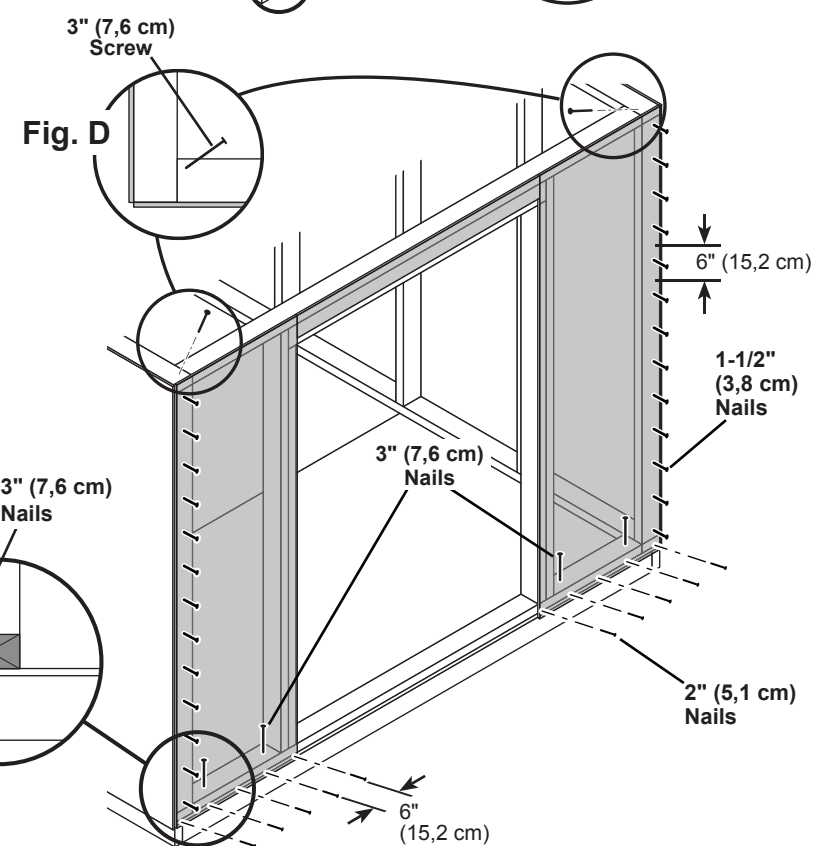

Your walls are now installed.

CUT OUT AND REMOVE BOTTOM PLATE AT DOOR OPENING.

RAFTERS

PARTS REQUIRED:

x12

x14 **TZA**
2 x 4 x 55-9/16" (5,1 x 10,2 x 141,1 cm)

Temporary Support
x1 **AL**
2 x 4 x 7"
(5,1 x 10,2 x 17,8 cm)

x144 2" (5,1 cm)

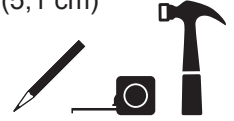

You will build 7 rafter assemblies.

✓ **BEGIN**

1 Place (2) rafters **TZA** on top of temporary support **AL** and flush to inside of 12' eave wall panels. Place gusset on top of rafters with 1/4" (19 mm) offset (**Fig. A**). Fasten gusset to rafters with (12) 2" nails in pattern shown.

2 For (2) rafters install (1) gusset and set aside. (**Fig. B**). For (5) rafters, flip over assembled rafter and install a second gusset (**Fig. C**).

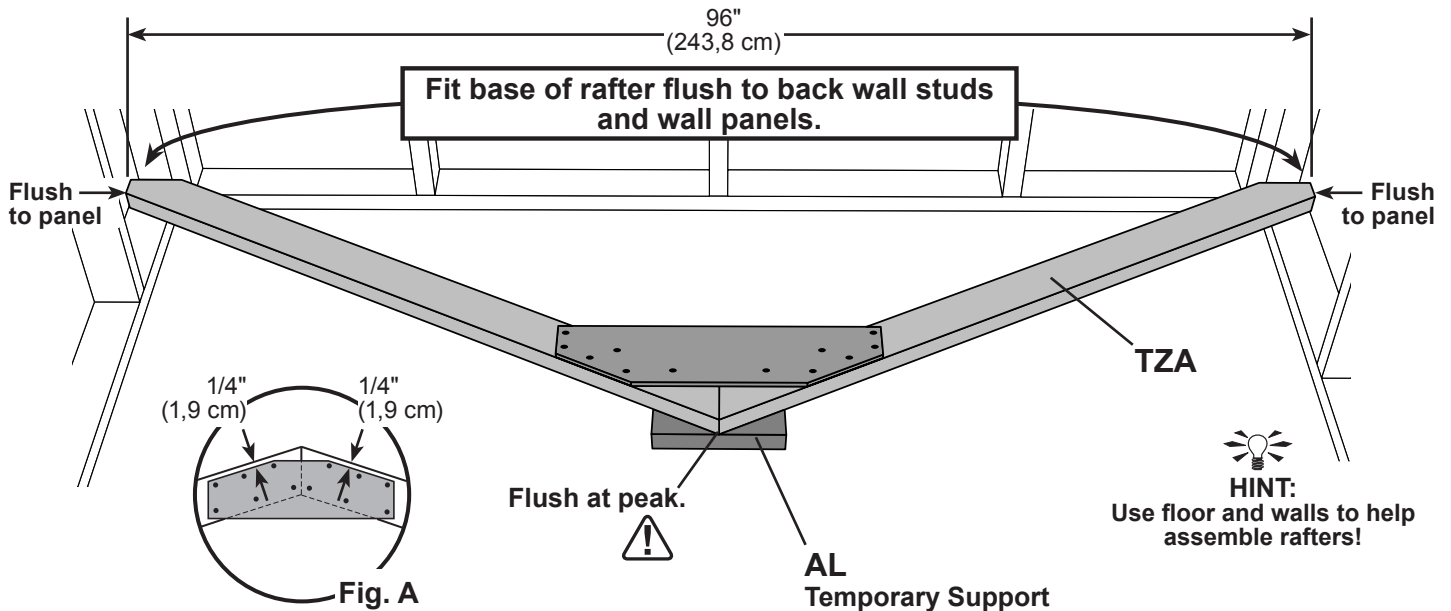

Fig. B - Build 2

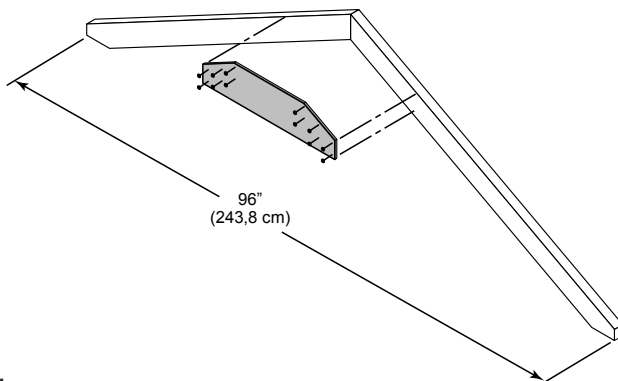
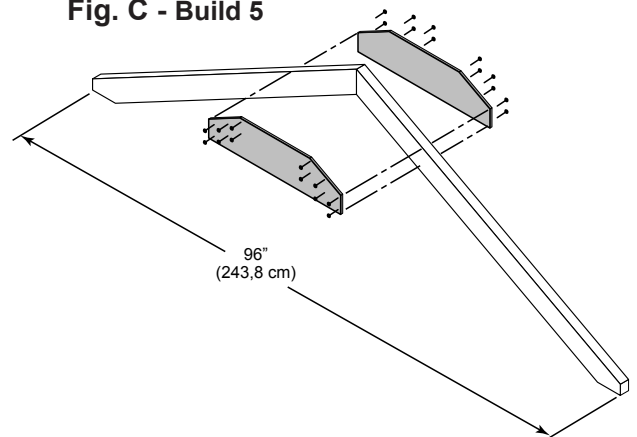

Fig. C - Build 5



Your rafters are now assembled.

RAFTER INSTALLATION

PARTS REQUIRED:

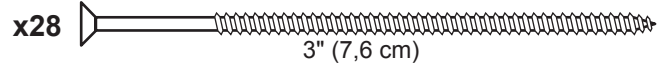
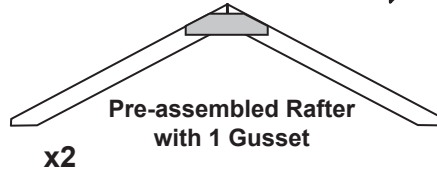
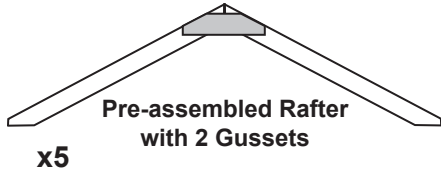

✓ **BEGIN**

- 1 Secure rafters to top plate at measurements shown with (2) 3" screws in rafter ends (**Fig. A**).
Install single-gusset rafters at each end, with gusset facing inward.

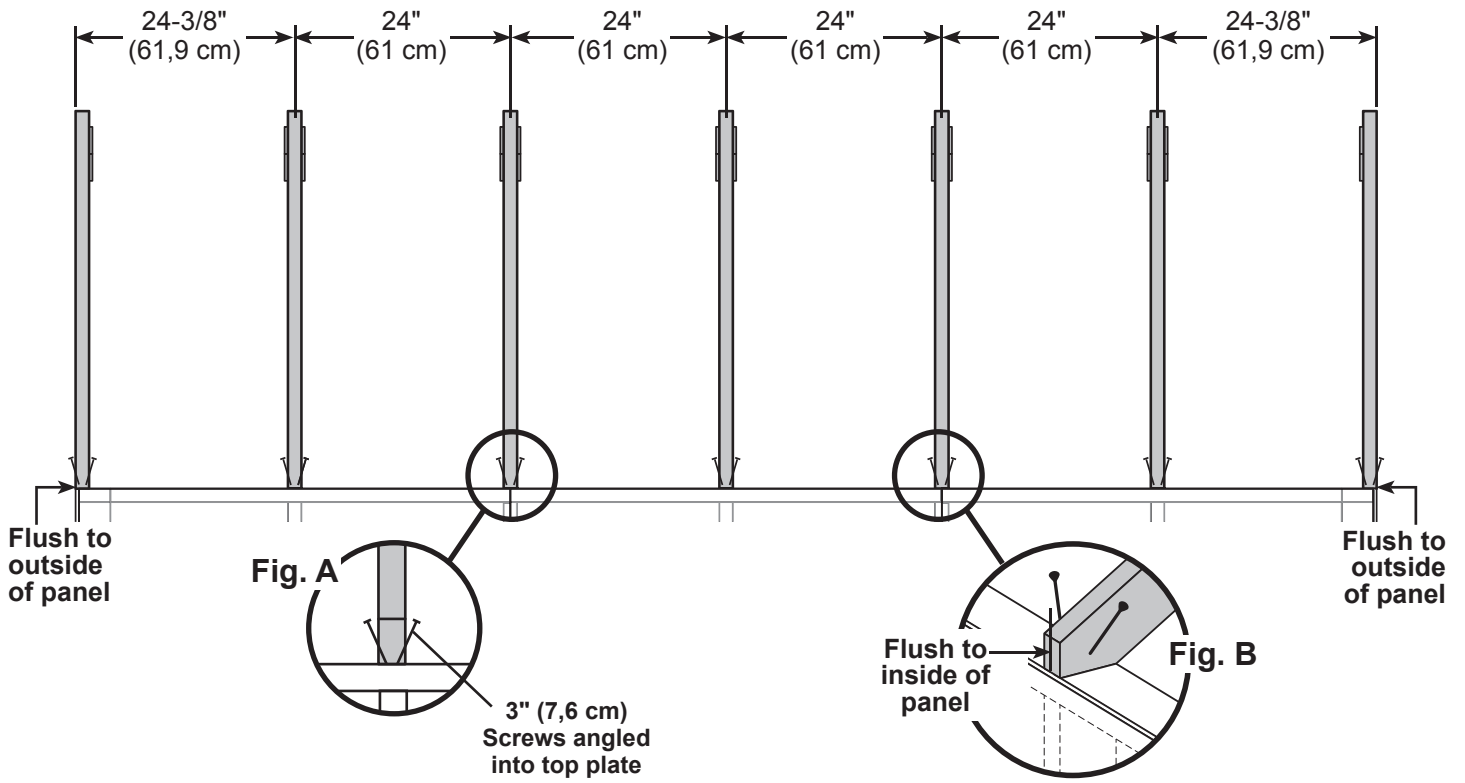

Your rafters are now installed.

GABLE UNITS

PARTS REQUIRED:

x4 **AL**
2 x 4 x 7"
(5,1 x 10,2 x 17,8 cm)

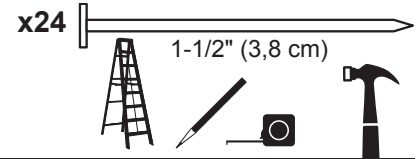
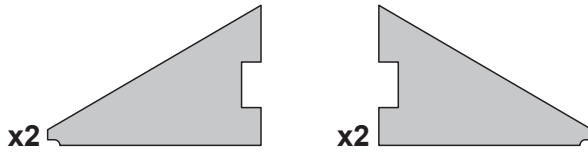

Install gable panels with the primed side facing up.

✓ **BEGIN**

- 1 Orient parts **AL** on the flat side, as shown.
Place left gable panel as shown. Secure with 1-1/2" nails as shown.

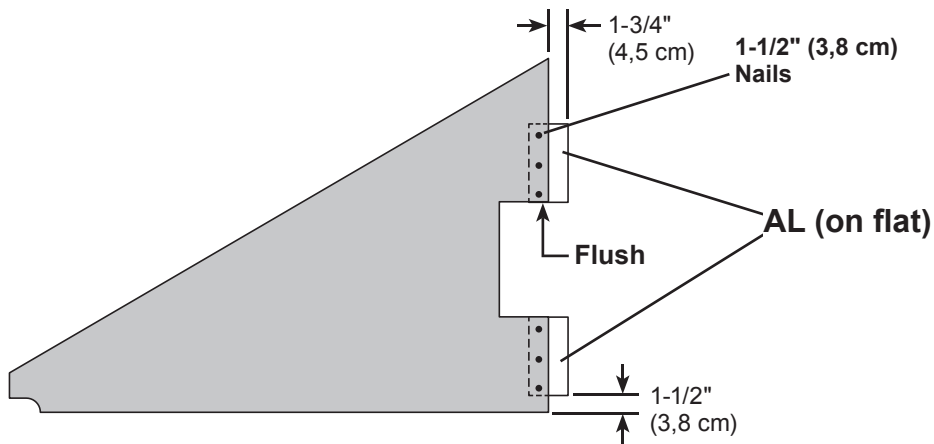

- 2 Place right gable panel flush to left panel. Secure with 1-1/2" nails as shown.

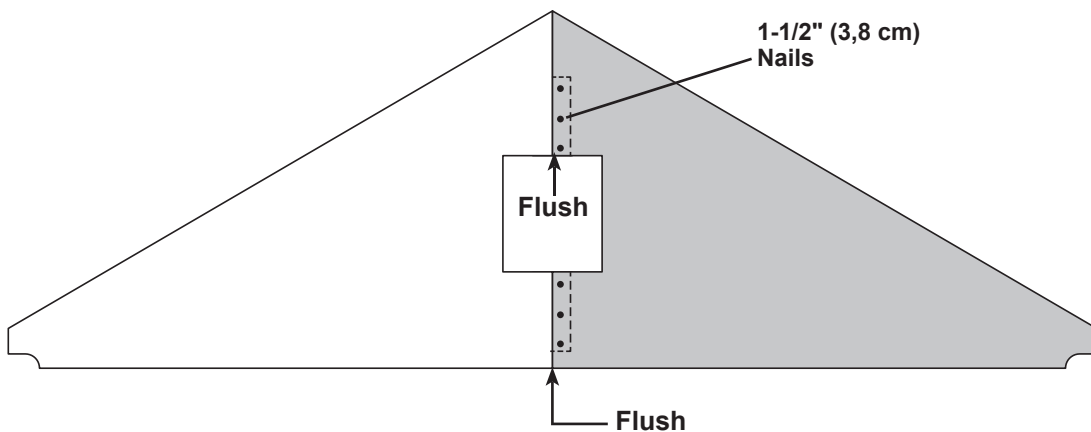

Repeat STEPS to build a 2nd gable unit.



Your gable units are now assembled.

GABLE UNIT INSTALLATION

PARTS REQUIRED:

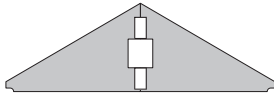
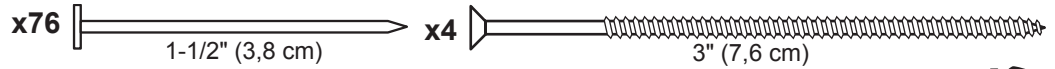

x2 Gable Units



✓ BEGIN

Place gable unit on front wall top plate.



⚠ It is important to secure the gable unit in the following order:

- 1 Measure 1-1/2" down from top plate and mark at each side as shown. Set gable unit on top plate. Hold secure with one 2" nail on each side.

⚠ **BE SURE GABLE IS CENTERED ON WALL BEFORE NAILING.** ⚠

- 2 Continue nailing lower edge of panels into top plate with 2" nails spaced 6" apart.

- 3 Working inside, secure gable unit with (2) 3" screws toe-screwed into **AL** at an angle as shown (**Fig. A**).

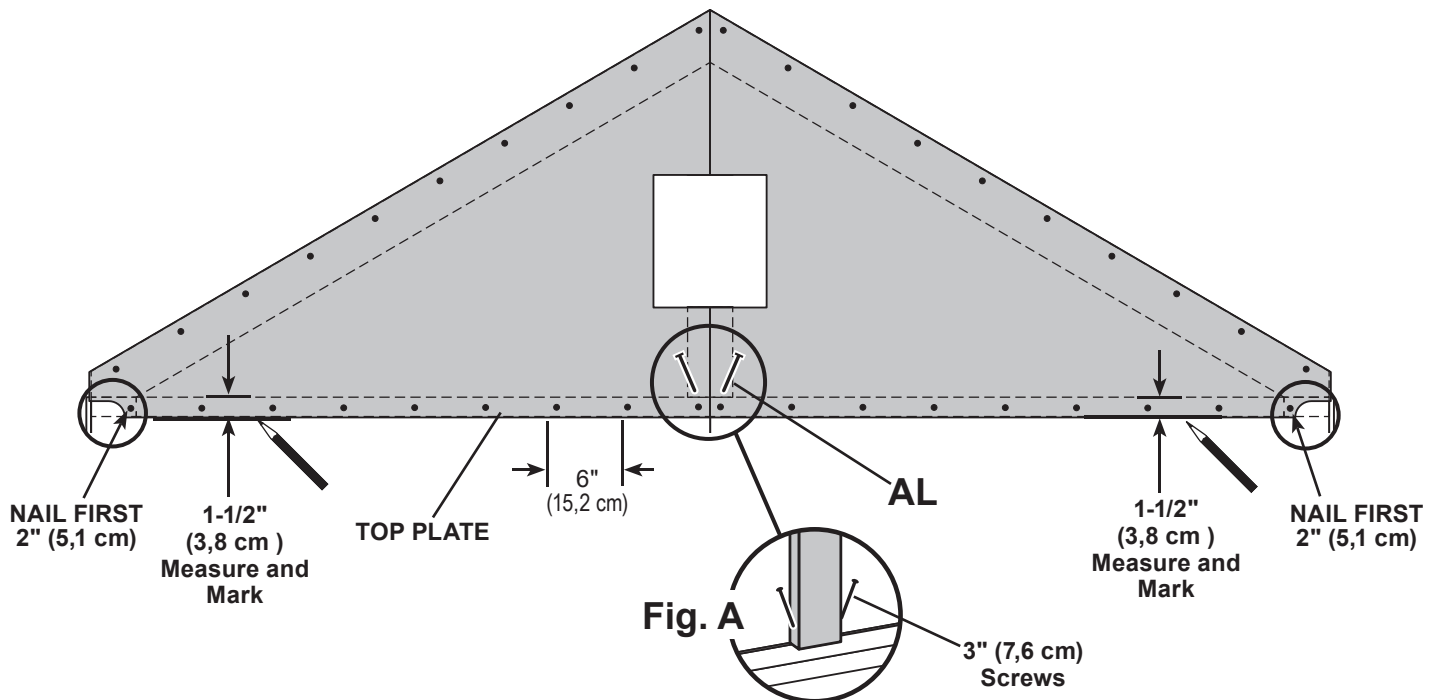

- 4 Continue securing panels to rafter with 2" nails spaced 6" apart.

Repeat STEPS 1 - 4 for the opposite side.



Your gable units are now installed

DOORS

PARTS REQUIRED:

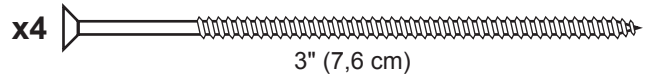
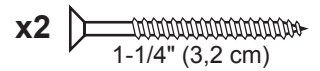
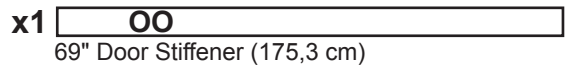
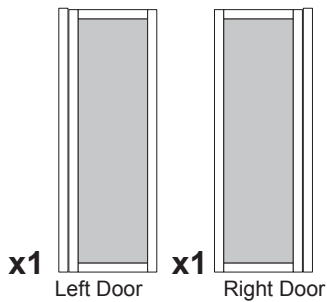

✓ **BEGIN**

- 1 Orient parts as shown on flat surface. **!** 3/8" offset is to top.
Look for red (right) and green (left) on hinge board.

Attach temporary support **OO** using 3" screws.

Attach temporary support **GAA** at bottom using 1-1/4" screws.

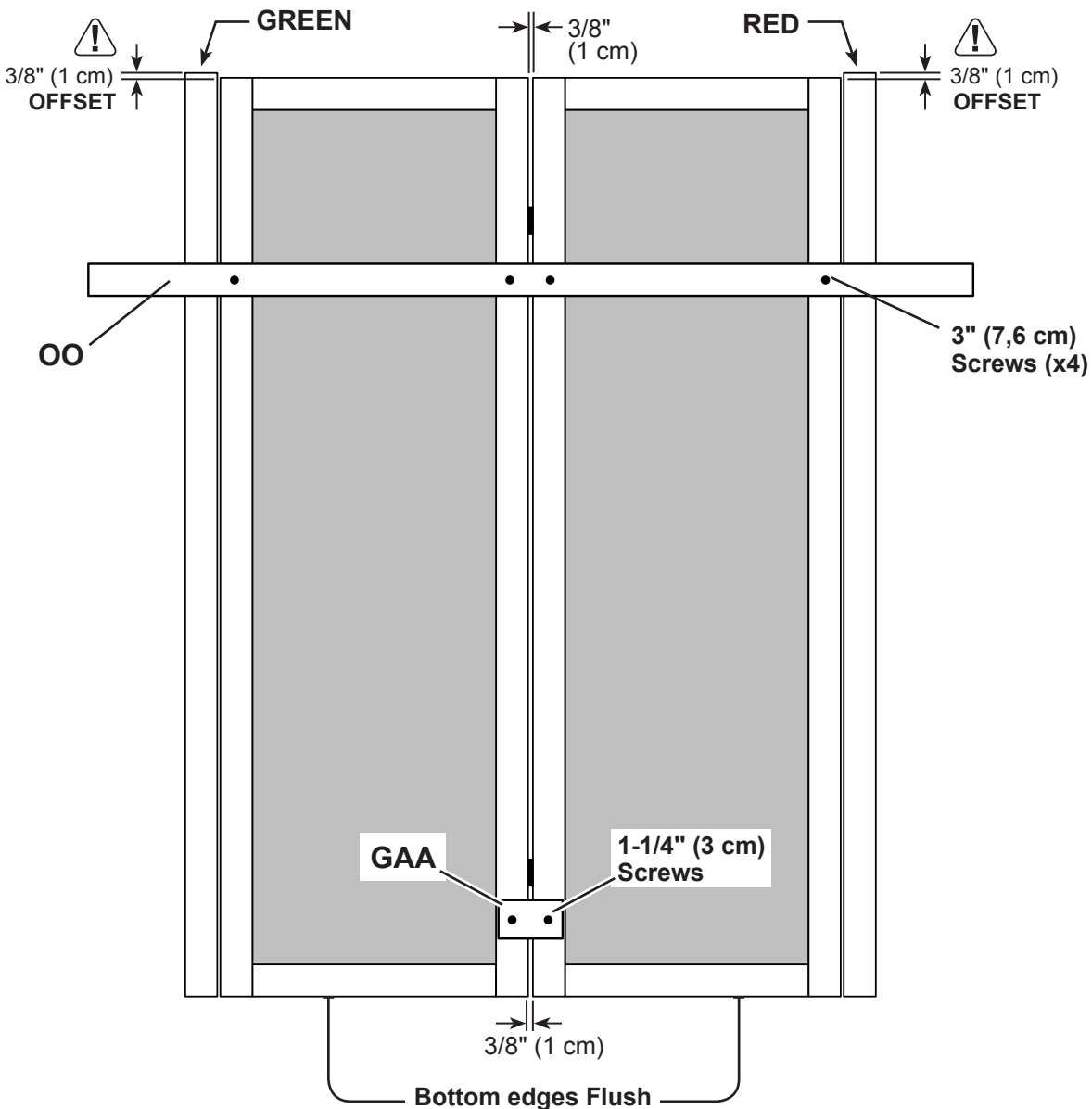

DOORS

PARTS REQUIRED:

x1 **OO**
69" (175,3 cm) Door Stiffener

x12  3" (7,6 cm)



✓ **BEGIN**

- 1 Install temporary support **OO** flush under wall panels.
Secure **OO** with (2) 3" screws (**Fig. A**).

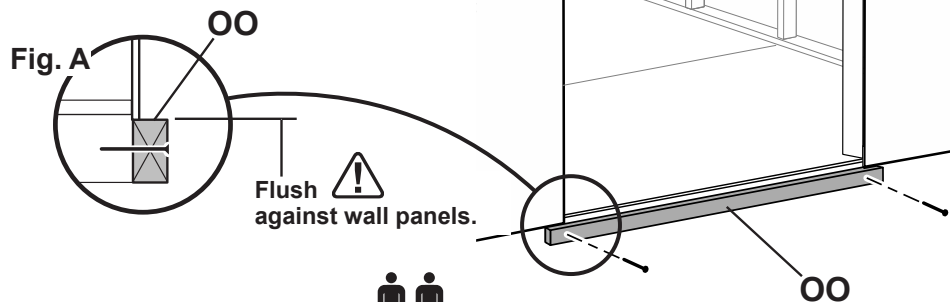

- 2 Center doors in door opening as shown (**Fig. B**). 
Fasten hinge boards to wall framing and floor with (10) 3" screws as shown.

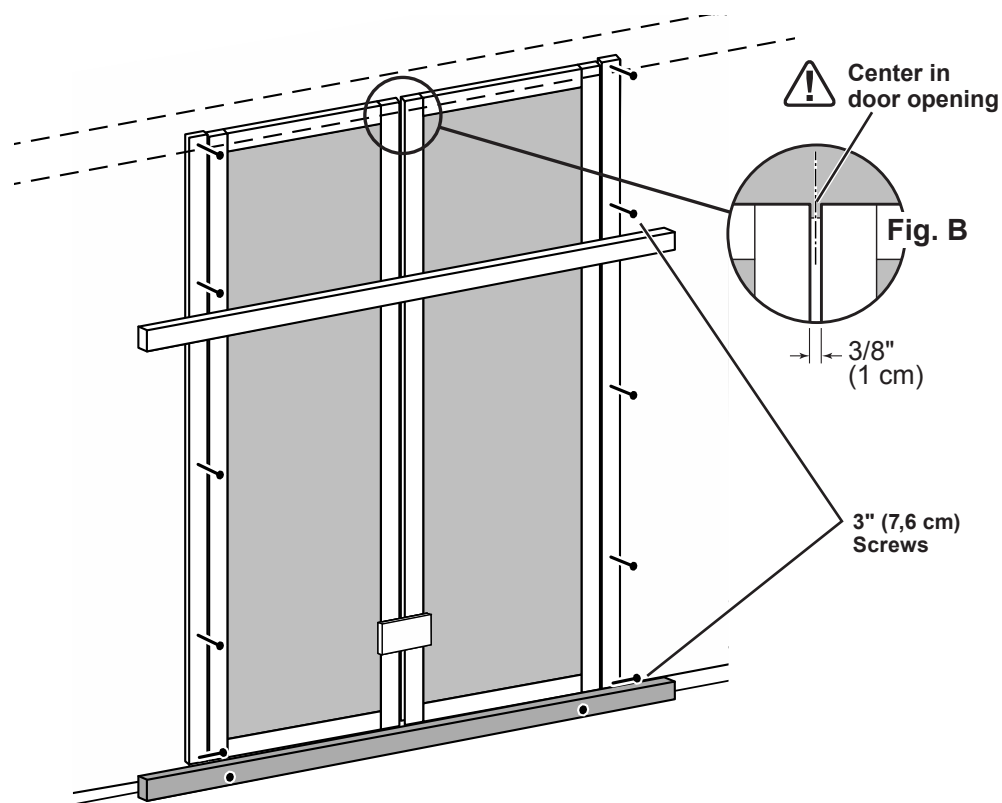

Remove temporary supports and check that the doors open properly.

DOOR TRIM

PARTS REQUIRED:

x2 **EGB** 19/32" x 2-1/2 x 18-5/8" (1,5 x 6,3 x 47,3 cm)

x2 **UWA** 19/32" x 2-1/2 x 32" (1,5 x 6,3 x 81,3 cm)

x1 **ZB** 19/32" x 2-1/2 x 55" (1,5 x 6,3 x 139,7 cm)

x46  3/4" (1,9 cm)

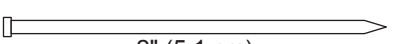
x5  2" (5,1 cm)

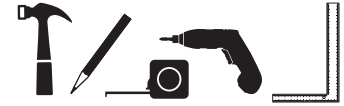

✓ BEGIN

- 1 Secure door trim from inside with 3/4" screws as shown (Fig. A). Attach door trim **EGB** and **UWA** with 3/4" screws from inside of doors.
- 2 Reinforce the door trim with 3/4" screws through door panel into trim (Fig. A). Locate screws as shown (Fig. B). Use (2) screws at seams.
- 3 Center trim **ZB** over doors and secure with (5) 2" finishing nails into framing.

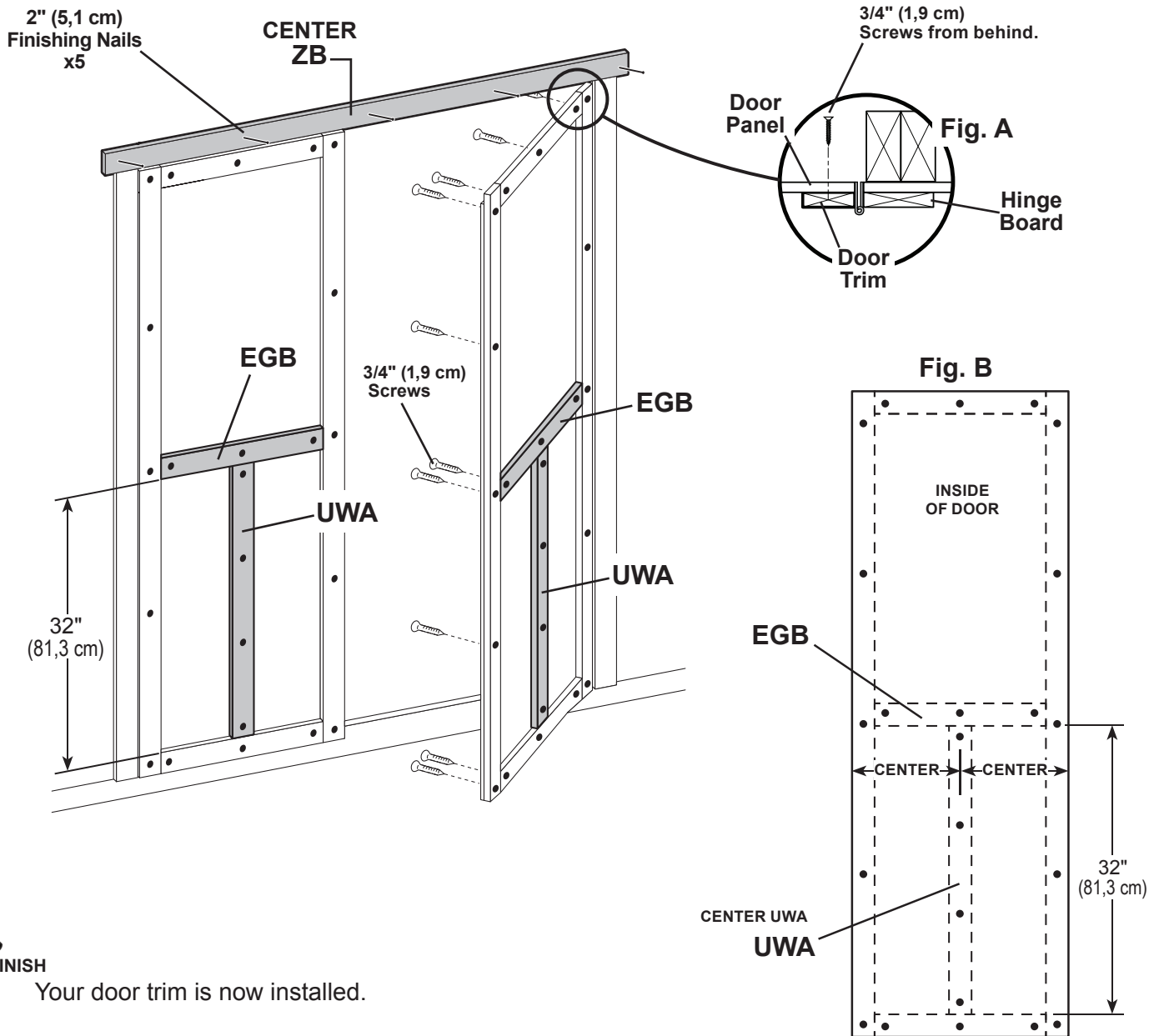

DOOR STIFFENERS

PARTS REQUIRED:

x2 **OO**
69" (175,3 cm) Door Stiffener

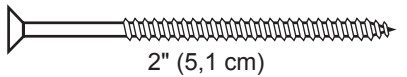
x14 
2" (5,1 cm)



✓ BEGIN

1 Center **OO** vertically on the left door in the doorway (**Fig. A**) overlapping 1" (2,5 cm) along the edge of door (**Fig. B**).

Secure with (7) 2" screws through outside trim into **OO**.

2 Center **OO** vertically on the right door in the door opening offset 1" (2,5 cm) from the edge of door (**Fig. B**).

Secure with (7) 2" screws through outside trim into **OO**.

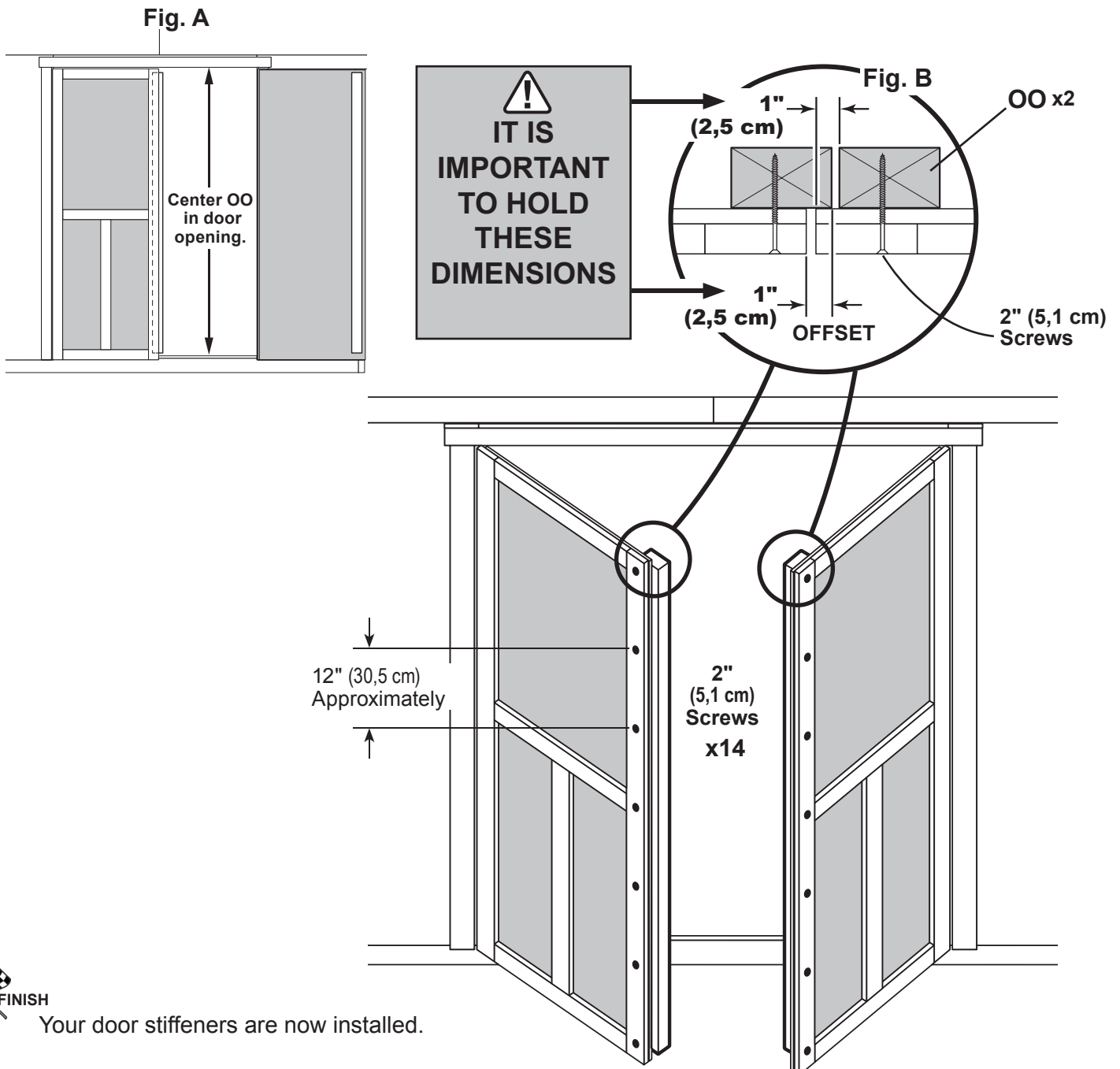

DOOR HARDWARE

PARTS REQUIRED:

x1

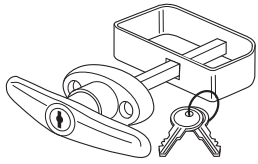

x2

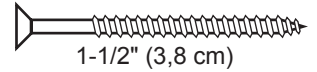

1-1/2" (3,8 cm)



1/4" (0,6 cm)

1/2" (1,3 cm)

Drill Bits

✓ BEGIN

- 1 Measure and mark position on right door as shown.
Pre-drill 1/4" hole at mark. Finish hole using 1/2" drill bit.

- 2 Position hardware in hole and secure with screws as shown.

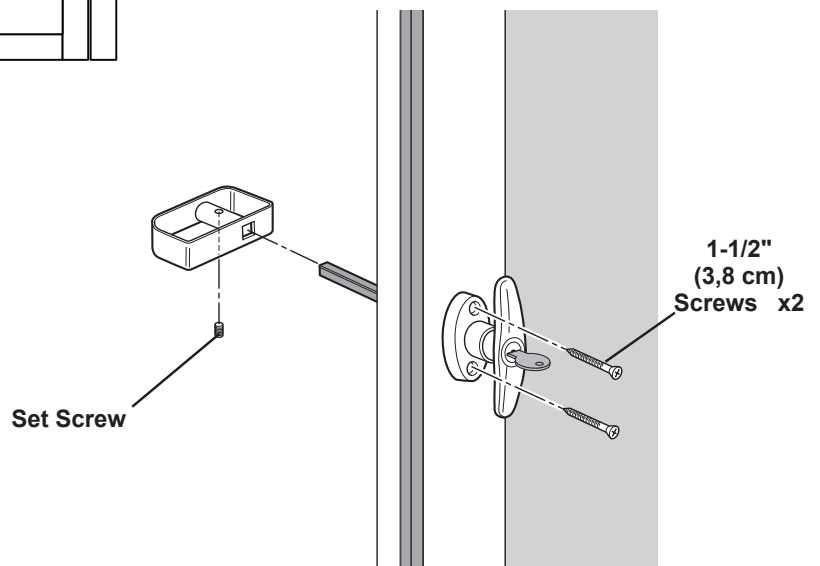
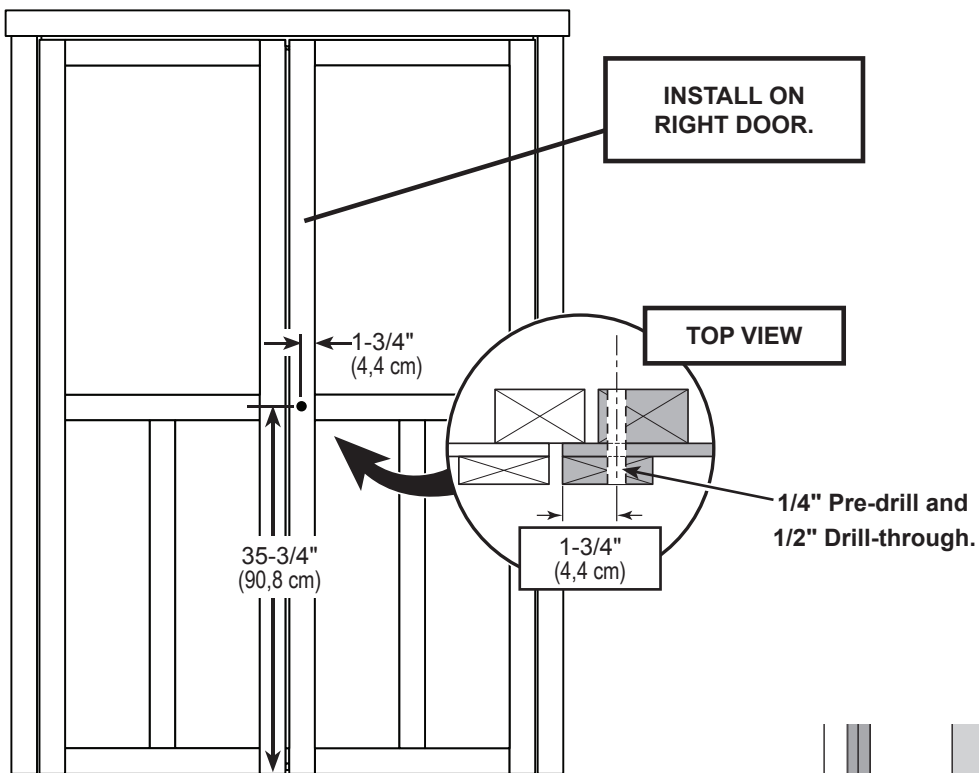

FINISH

Your door handle is now installed.

DOOR HARDWARE

PARTS REQUIRED:

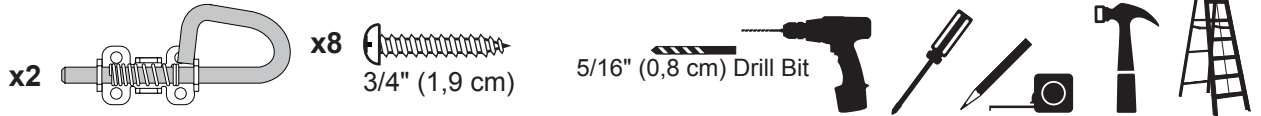

✓ BEGIN

- 1 Place bolt on **OO** in open position with bolt end 3/8" (0,8 cm) down from frame. Bolt is open when loop is contacting base (**Fig A**).
- 2 Mark and pre-drill holes for screws. Install bolt with screws supplied.
Drill 5/16" (0,8 cm) hole deep enough for bolt to slide into.
- 3 Place bolt on **OO** in open position with bolt end 1/2" (1,3 cm) up from floor. Bolt is open when loop is connecting base (**Fig. B**).
- 4 Mark and pre-drill holes for screws. Install bolt with screws supplied.
Drill 5/16" (0,8 cm) hole deep enough for bolt to slide into.



HINT: With door closed extend bolt and tap with hammer to leave a mark in wood for drilling.

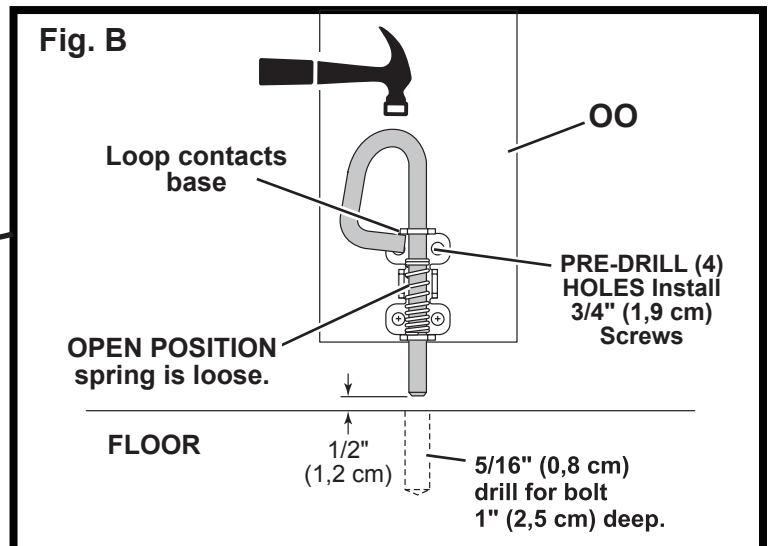
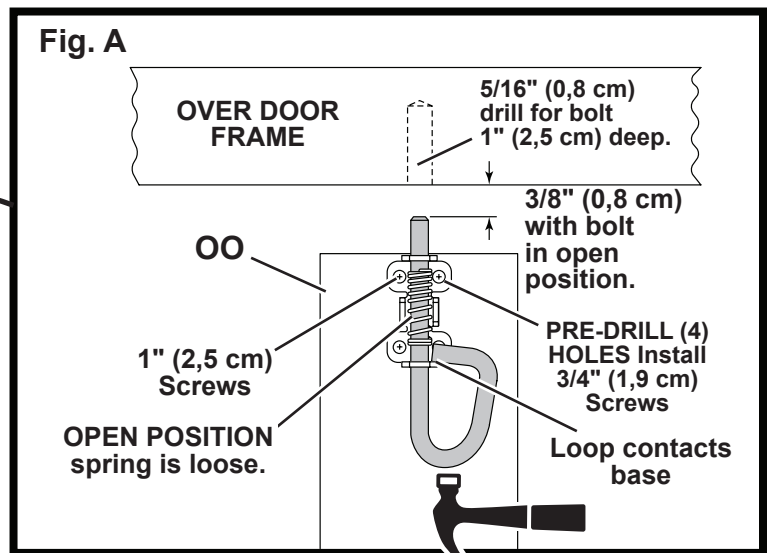
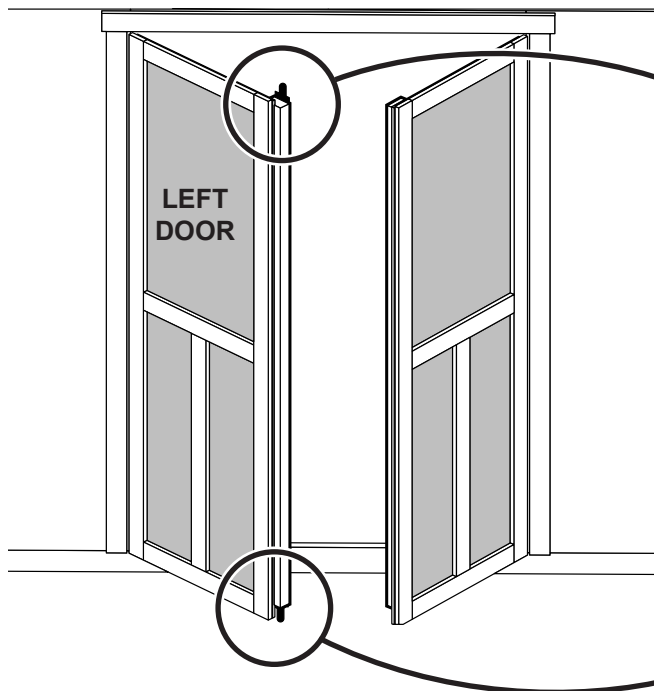

FINISH

Your spring bolts are now installed.

ROOF PANELS

PARTS REQUIRED:

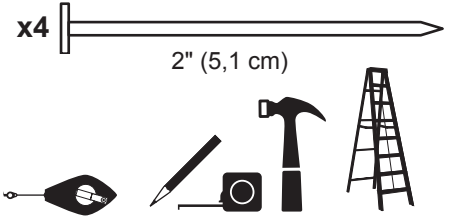
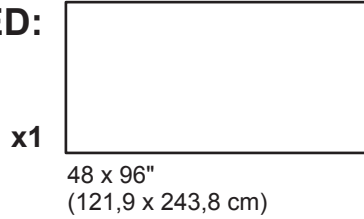

Roof panels may cause serious injury until securely fastened.

Note: Install all roof panels with the rough side up (painted grid lines).

✓ BEGIN

- 1 Place the 48" x 96" panel on rafters with a 3/4" measurement on the rafter (Fig A) and the panel flush at the peak (Fig. B).



Secure panel with (2) 2" nails in the corners.

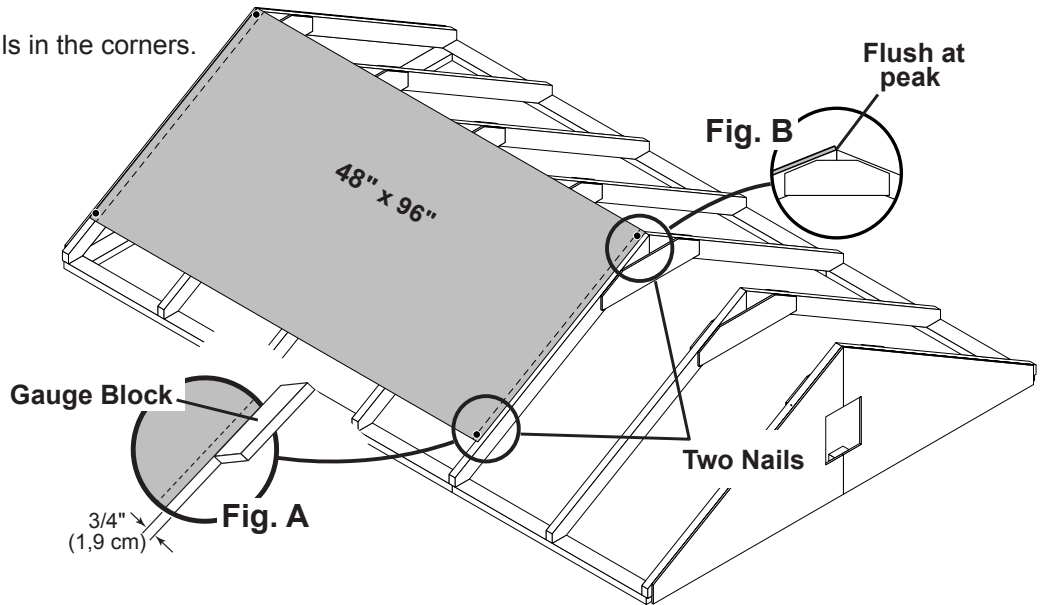

- 2 Move to the opposite end. Using the long edge of the panel as a lever, move the panel side-to-side until the top corner is flush to the peak (Fig. B) and there is a 1/2" measurement on the gable end rafter (Fig. C).

Secure panel with (2) 2" nails in the corners.

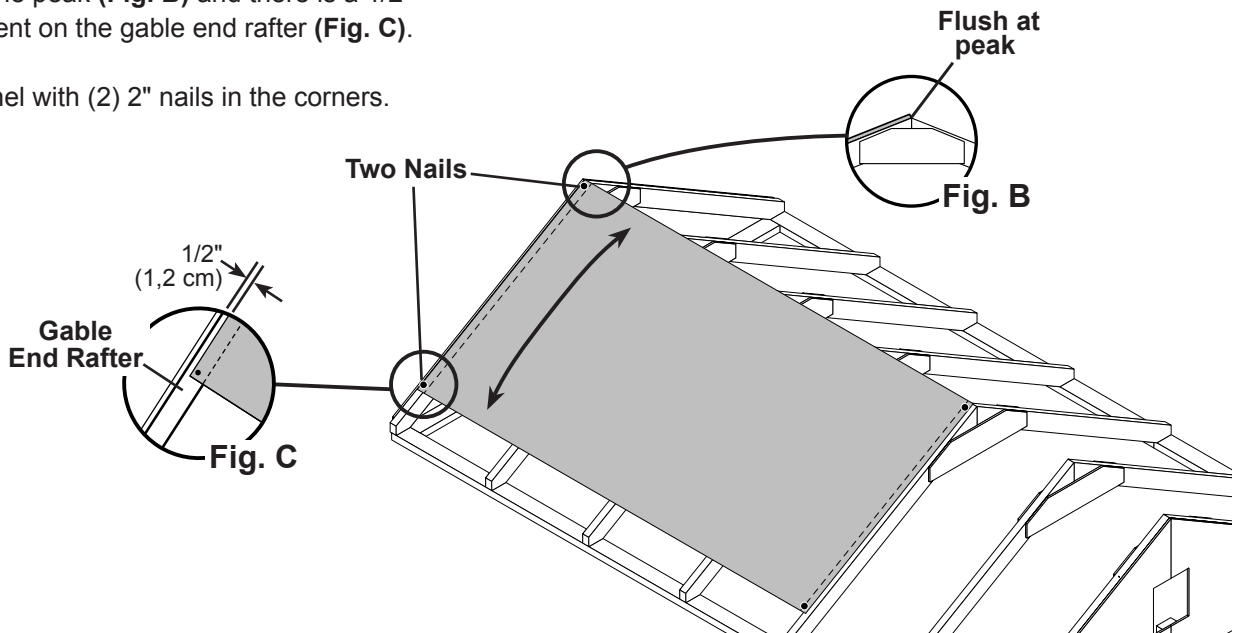

ROOF PANELS

PARTS REQUIRED:

x1 
 13-7/8" x 48"
 (35,2 x 121,9 cm)

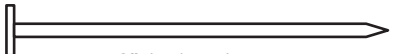
x12 
 2" (5,1 cm)

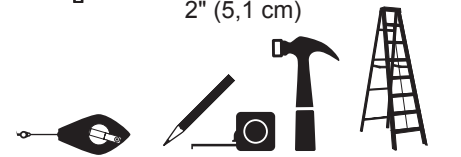

- Install a 13-7/8" x 48" roof panel flush to the installed panel and flush at peak (Fig. B).

Secure panel with (2) 2" nails in the corners.

- Move the gable until it is at 1/2" (Fig. C) from the 13-7/8" x 48" roof panel.

Finish securing panel with (2) 2" nails in the corners.

- Maintain spacing between the center of the rafters at the lower edge of the panels (Fig. D).

Secure panels with (1) 2" nail into each rafter.

Move to the top of the panel and keep spacing between the center of the rafters.

Secure panels with (1) 2" nail into each rafter.

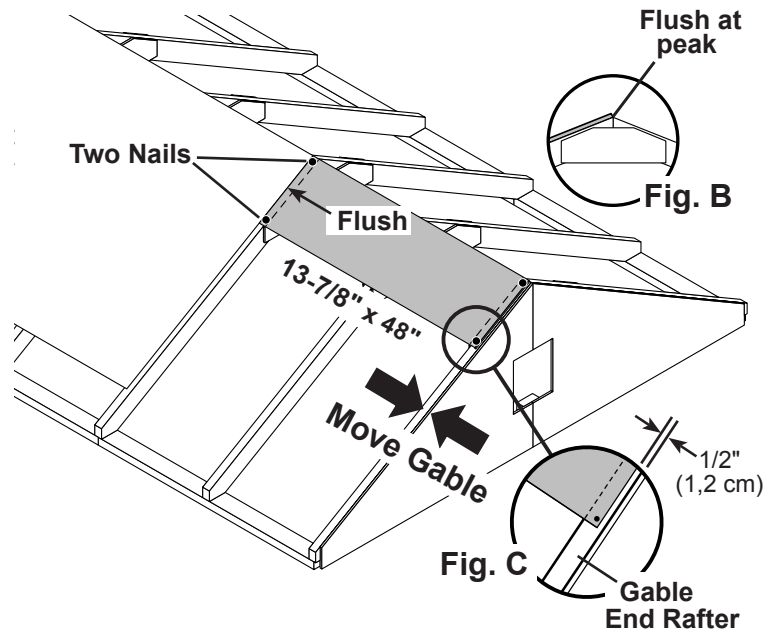
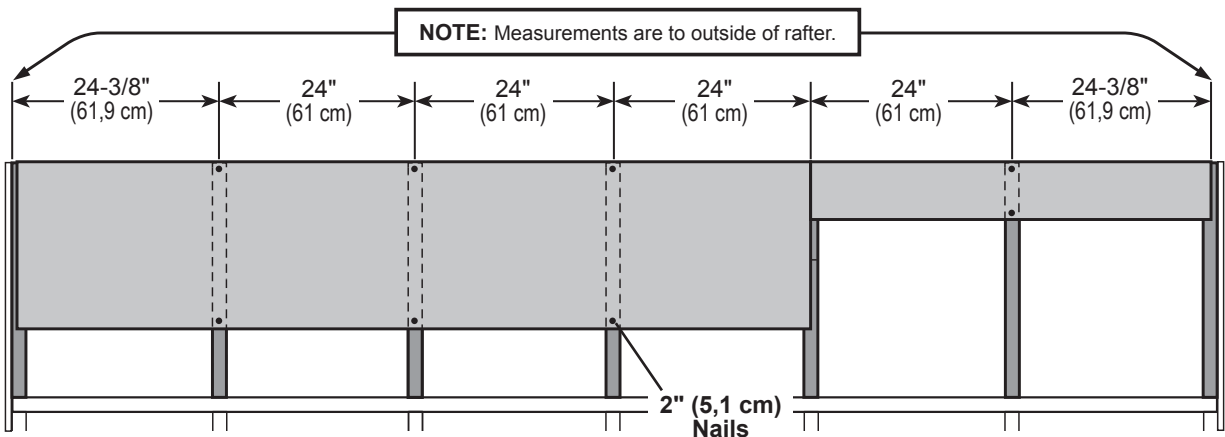

Fig. D



ROOF PANELS

PARTS REQUIRED:

GAA
3/4" GAUGE
BLOCK

x1

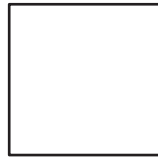

47-7/8 x 48"
(121,6 x 121,9 cm)

x1

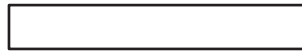

13-7/8 x 96"
(35,2 x 243,8 cm)

x8

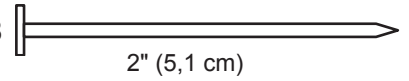

2" (5,1 cm)

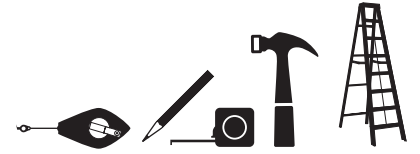

- 6** Install 13-7/8" x 96" and 47-7/8" x 48" roof panels with a 3/4" measurement on the rafter (Fig A) and flush to the installed panels.

Secure panel with (1) 2" nail in each corner.

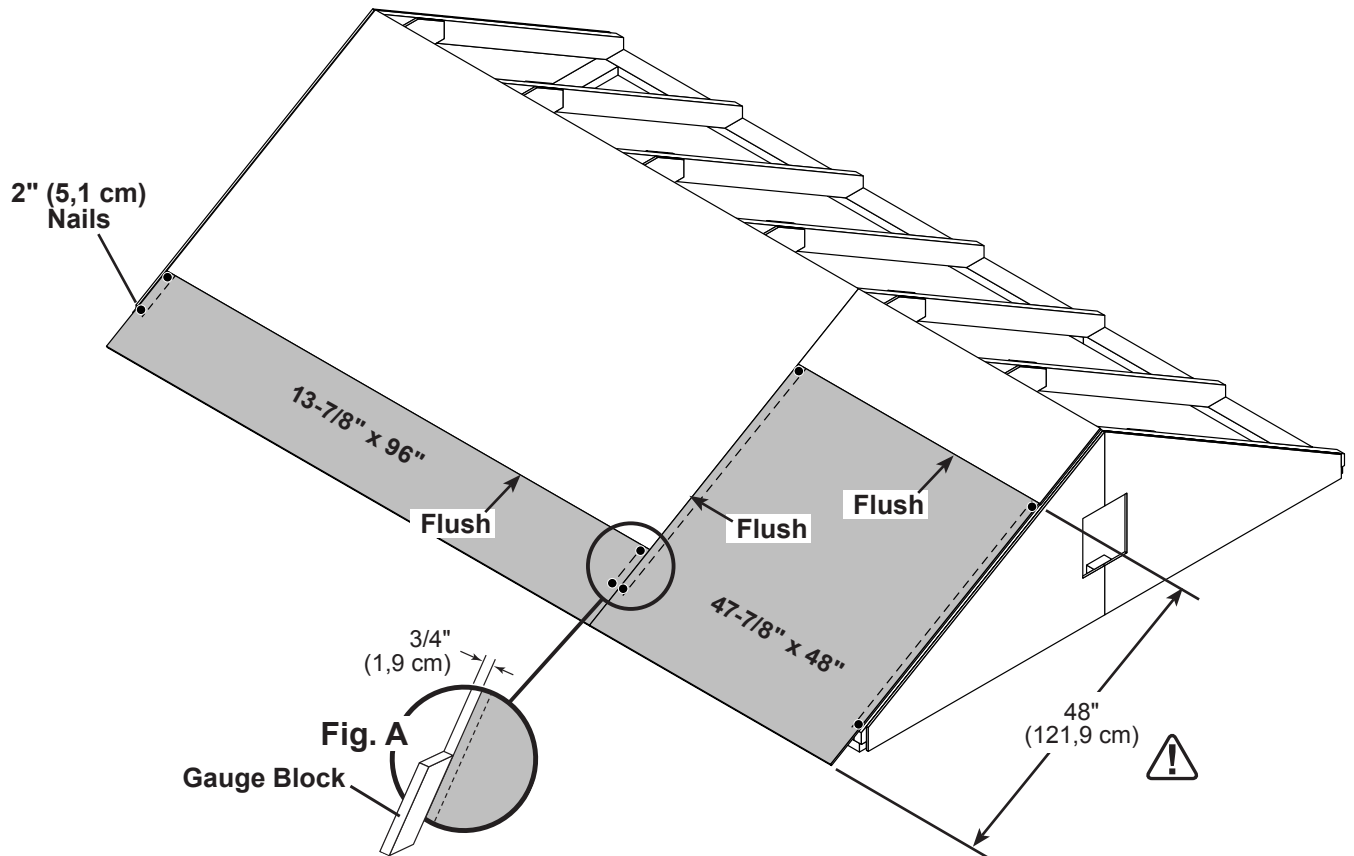

ROOF PANELS

PARTS REQUIRED:

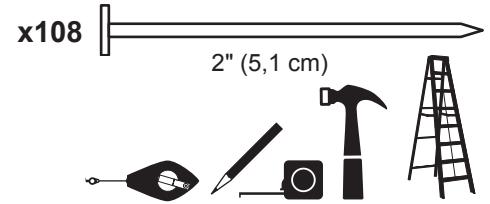

- 7 Secure all roof panels with 2" nails spaced 6" apart on edges and 12" apart inside panel.

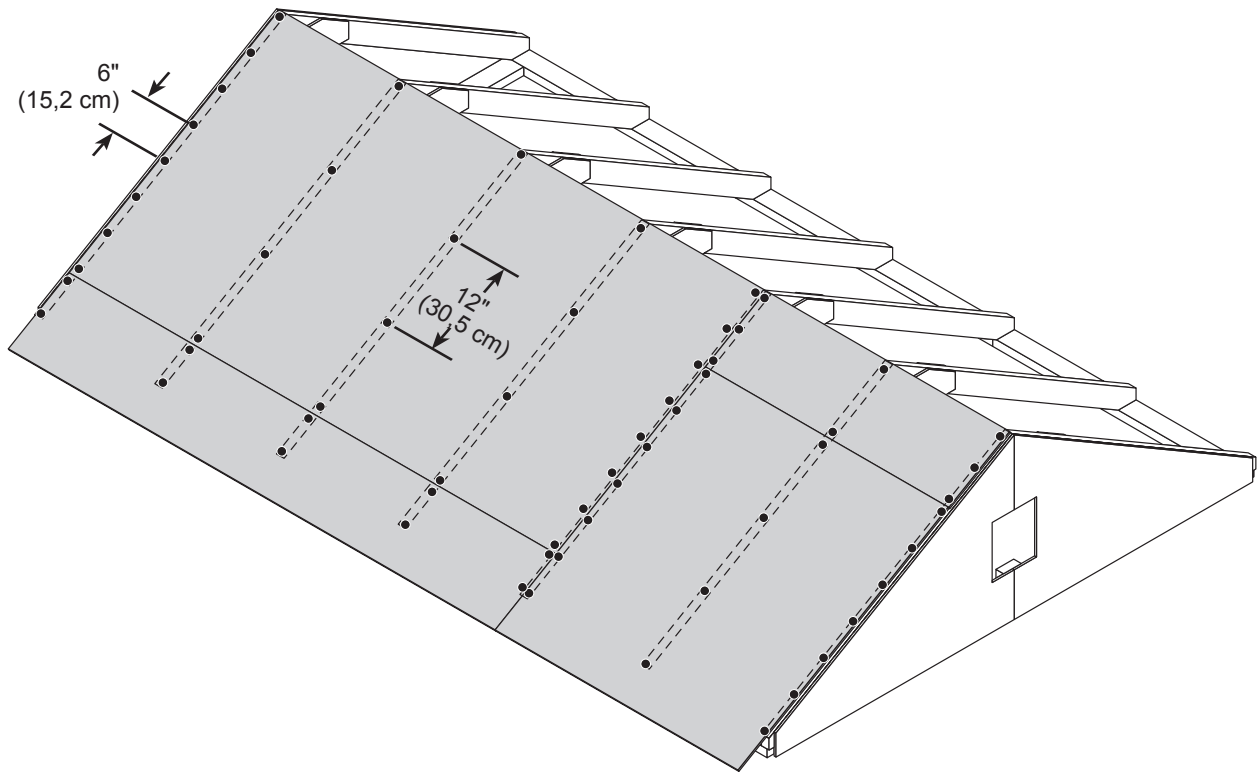

Repeat STEPS to install roof panels on the opposite side.

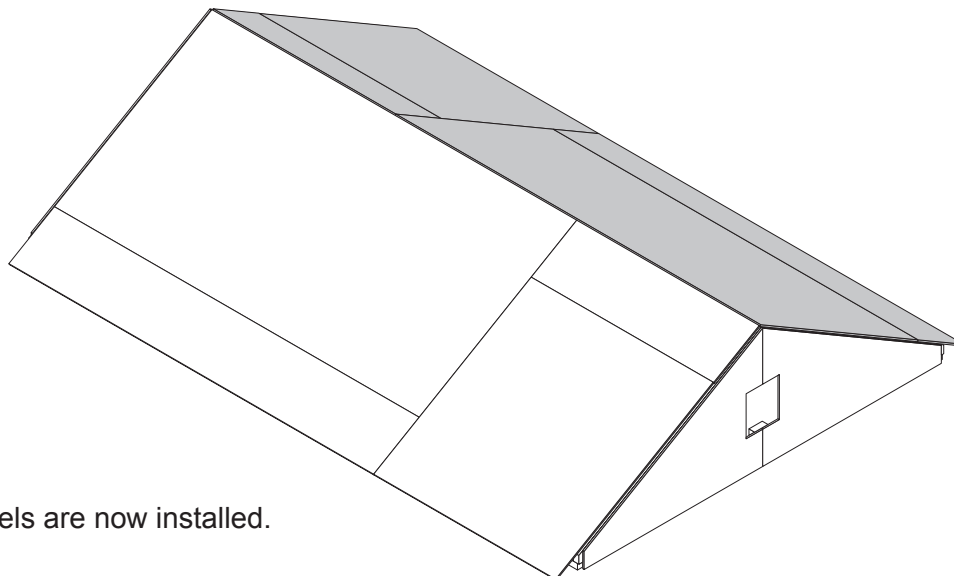



Your roof panels are now installed.

GABLE TRIM

PARTS REQUIRED:

x4 **NXC** 
2 x 4 x 62-3/16" (5,1 x 10,2 x 158 cm)

x2 **HUL** 
19/32 x 3-1/2 x 62-3/16" (1,5 x 8,9 x 158 cm)

x2 **HUR** 
19/32 x 3-1/2 x 62-3/16" (1,5 x 8,9 x 158 cm)

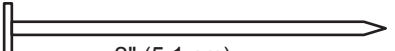
x24 
2" (5,1 cm)

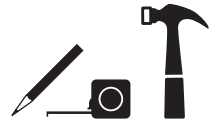

✓ BEGIN

1 Place parts **HUL** and **HUR** primed side down on top of 2x4 parts **NXC**.

Assemble parts flush at corners, as shown.

Secure parts with 2" nails spaced evenly.

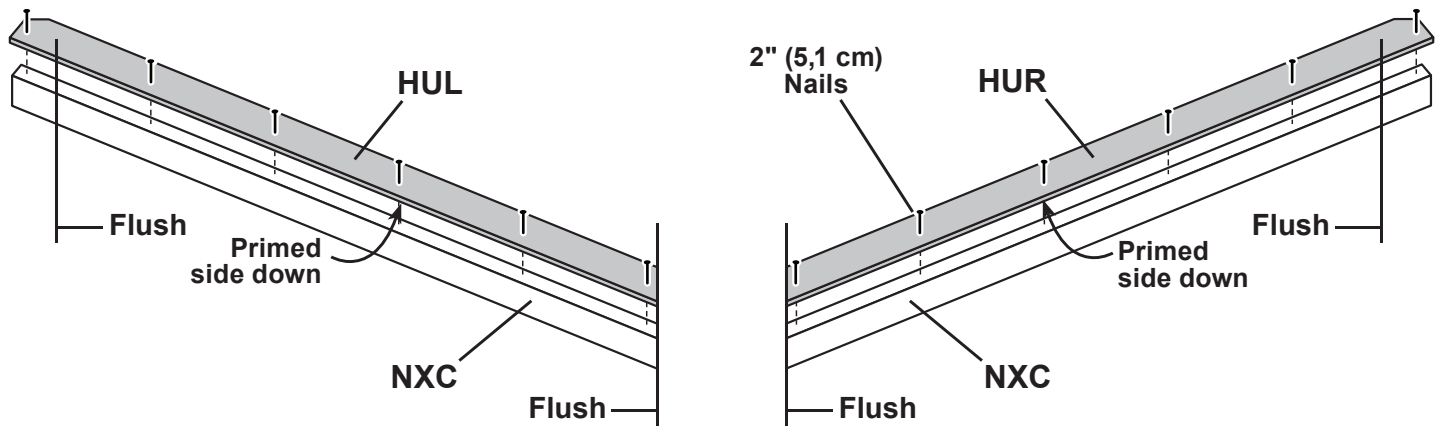

Repeat steps to assemble trim for opposite side.



Your gable trim pieces are now assembled.

GABLE TRIM

PARTS REQUIRED:

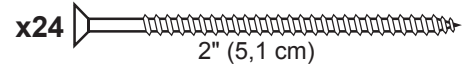
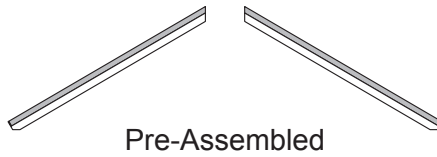
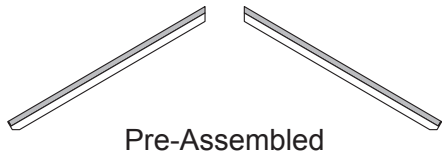

✓ BEGIN

- 1 Install assembled gable trim pieces flush to roof panels (Fig. A).
Secure gable pieces with 2" screws spaced evenly.

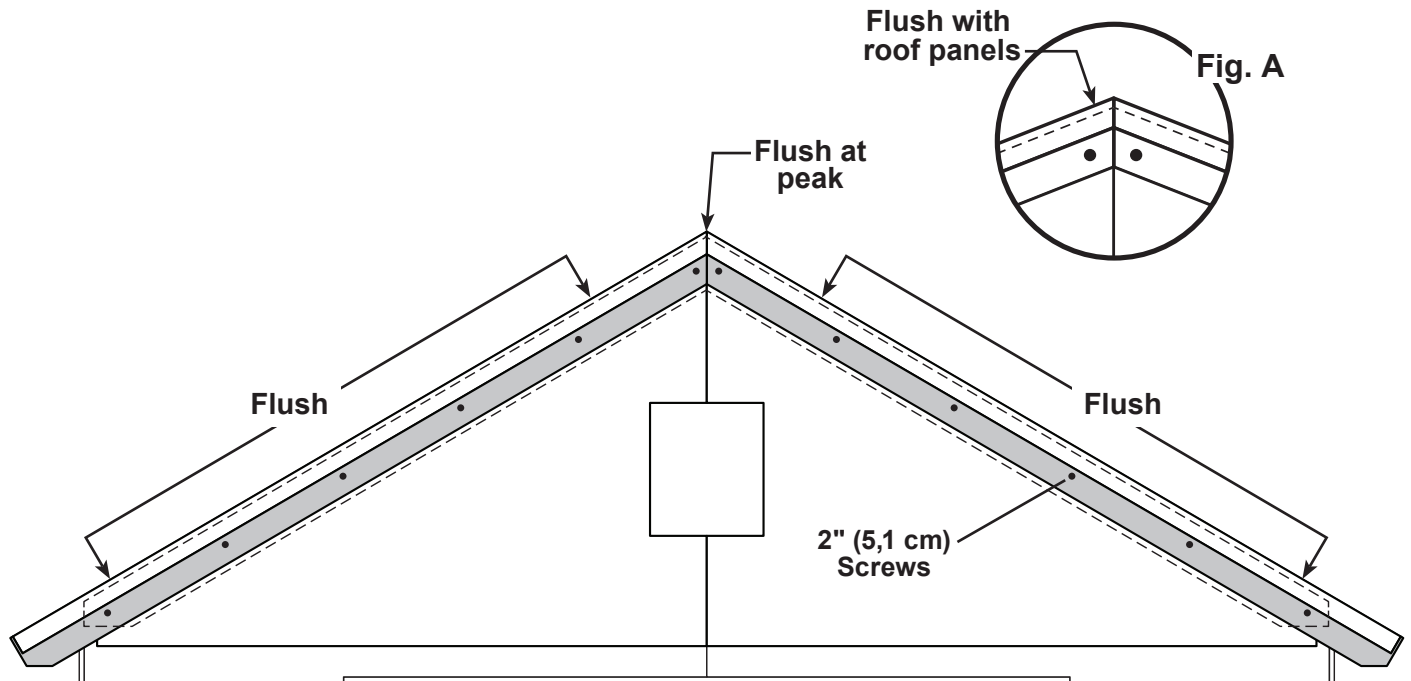

Repeat steps for opposite side of shed.



Your gable trim is now installed.

EAVE SOFFIT

PARTS REQUIRED:

x2 **AS**
2 x 6 x 49-1/2" (5,1 x 16,2 x 125,7 cm)

x2 **VX**
2 x 6 x 96" (5,1 x 15,2 x 243,8 cm)

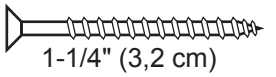
x78  1-1/4" (3,2 cm)



✓ **BEGIN**

1 Install **AS** flush to **VX** and flush to roof panels (**Fig. A**).

Secure with 1-1/4" screws evenly spaced and following the pattern shown.

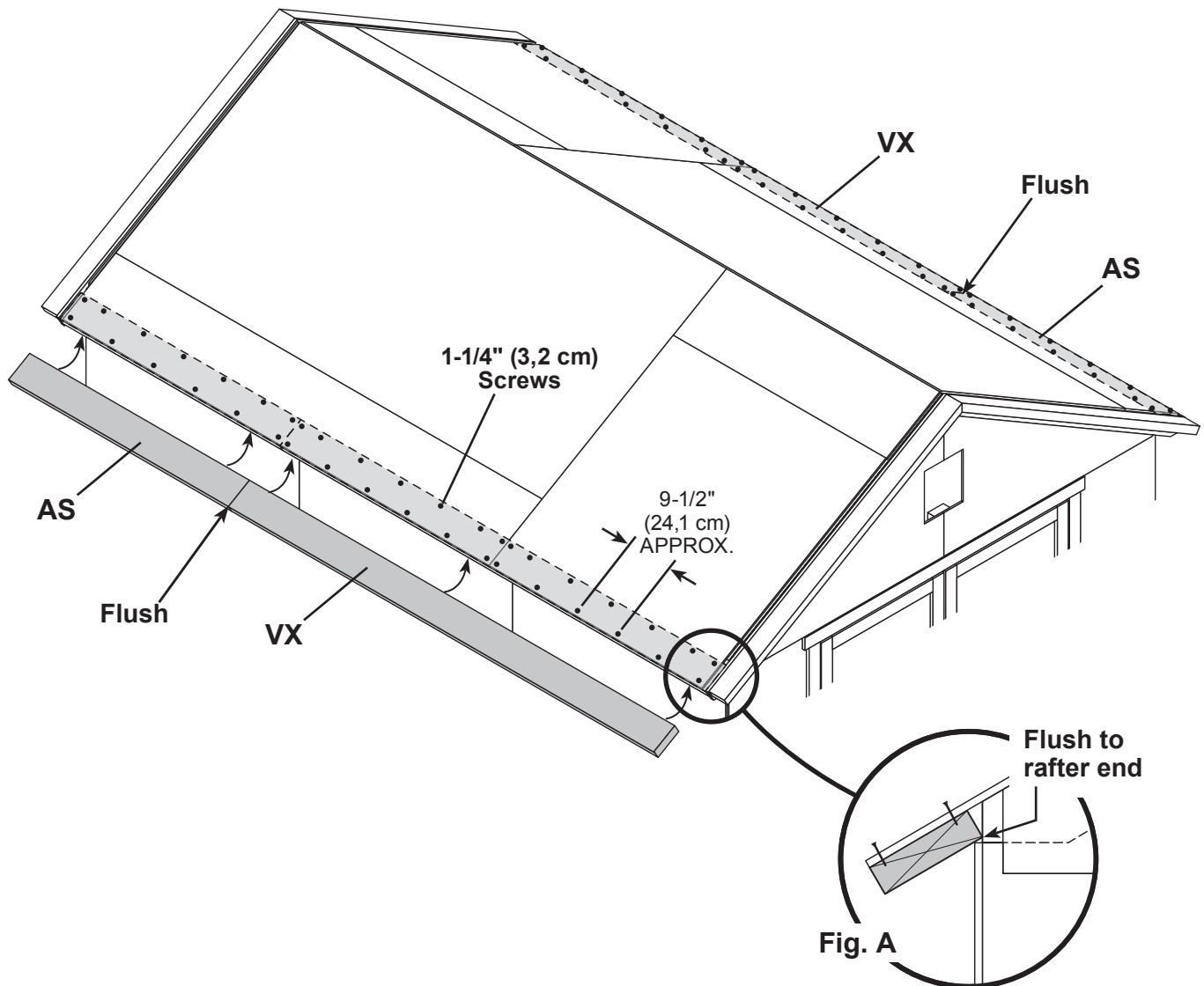

Your eave soffits are now installed.

GABLE FASCIA

PARTS REQUIRED:

x1 **YOL**
19/32 x 2-1/2 x 63-1/16" (1,5 x 6,3 x 160,2 cm)

x1 **YOR**
19/32 x 2-1/2 x 63-1/16" (1,5 x 6,3 x 160,2 cm)

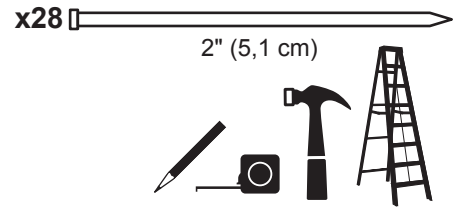

✓ **BEGIN**

- 1 Install gable trim **YOL** and **YOR** flush to roof panels (**Fig. A**).
Secure trim with 2" finishing nails evenly spaced.

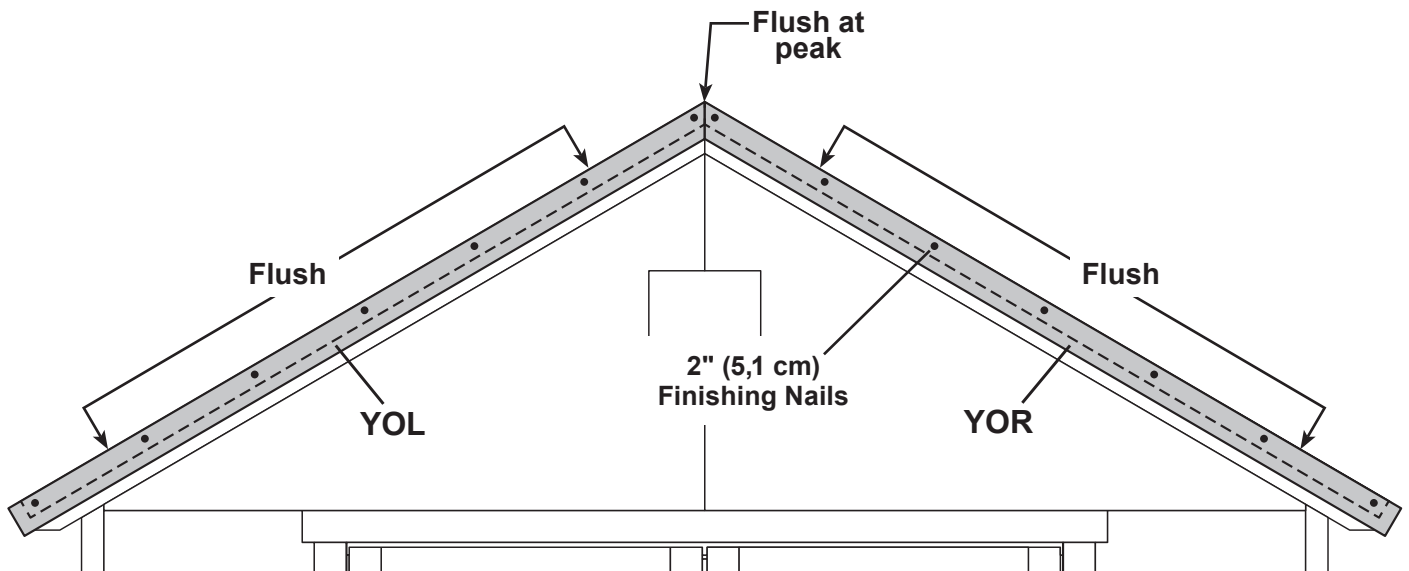

Repeat steps for opposite side of shed.



Your gable trim is now installed.

EAVE FASCIA

PARTS REQUIRED:

x1 **JUB**
19/32 x 2-1/2 x 62-3/4" (1,5 x 6,3 x 159,4 cm)

x1 **BSA**
19/32 x 2-1/2 x 91" (1,5 x 6,3 x 231,1 cm)

x18  2" (5,1 cm)



✓ **BEGIN**

- 1 Install eave trim **JUB** flush to **BSA** and flush to top of roof panels.
Fasten trim to 2x6 soffit with 2" finishing nails evenly spaced.

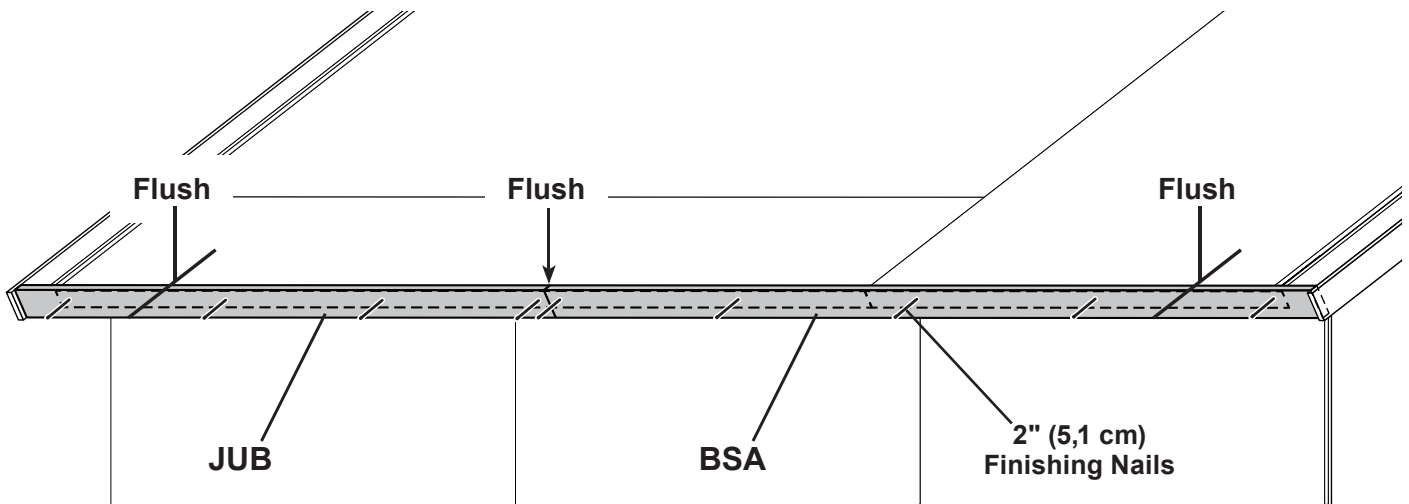

Repeat steps for opposite side of shed.

 **FINISH**

Your eave trim is now installed.

CORNER TRIM

PARTS REQUIRED:

x8 
3/8 x 1-3/4 x 75-3/4" (1 x 4,4 x 192,4 cm)

x56  2" (5,1 cm)

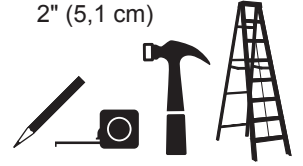

✓ **BEGIN**

- 1 Install gable end **75-3/4"** corner trim under gable panel, **(Fig. A)** and flush to eave wall panel **(Fig. B)**. Secure with 2" finishing nails spaced evenly.
- 2 Install eave side **75-3/4"** corner trim flush to eave soffit and flush along seam of installed corner trim **(Fig. C)**. Secure with 2" finishing nails spaced evenly.

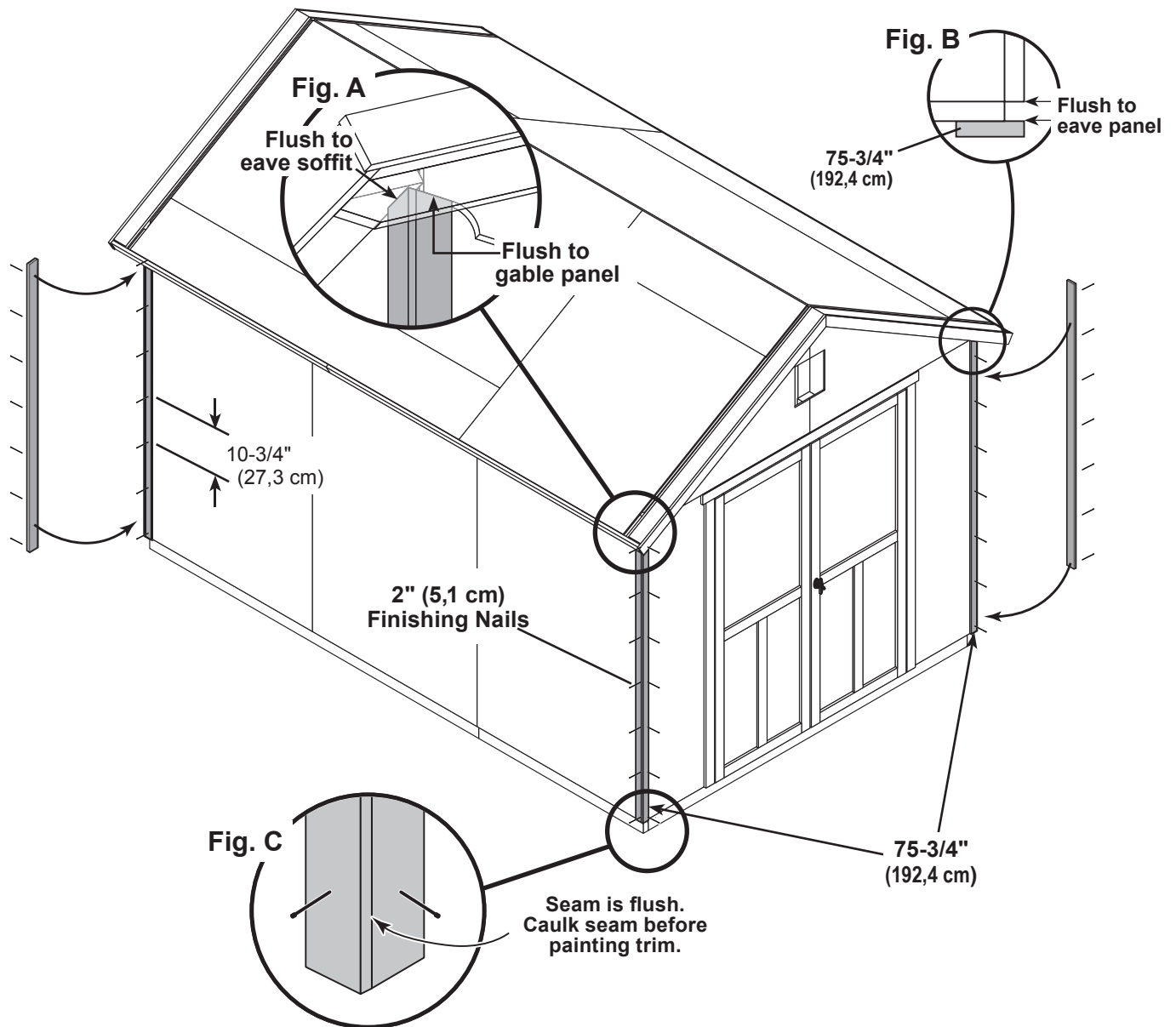

Repeat STEPS 1 - 2 for each corner of shed.



Your corner trim is now installed.

COLLAR TIES

PARTS REQUIRED:

x2 **JF**
1 x 4 x 60" (2,5 x 10,2 x 152,4 cm)

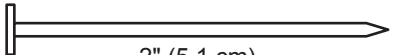
x12  2" (5,1 cm)



✓ BEGIN

1 Position and level collar ties **JF** on 2nd rafters from each gable.



HINT: For best appearance install collar tie on rafter facing away from a doorway.

Secure collar ties with 2" nails as shown.

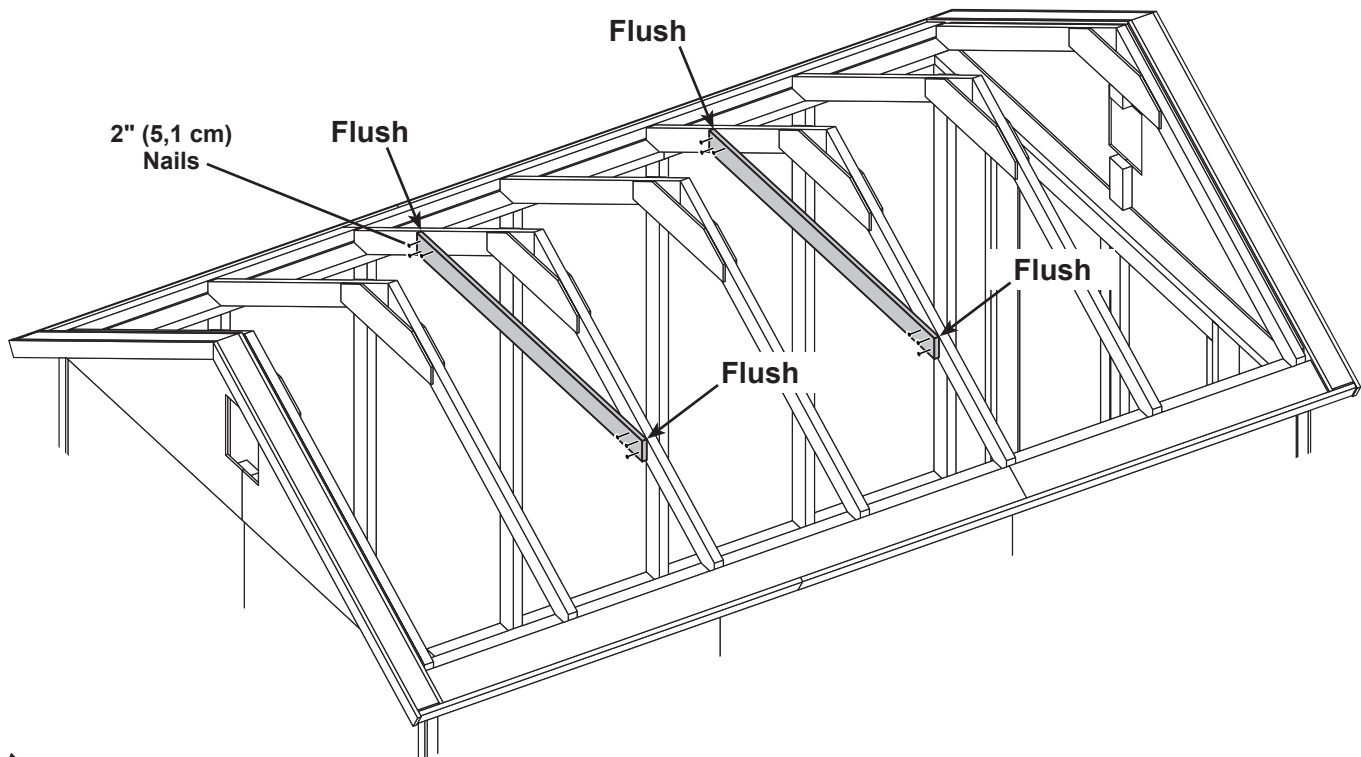

FINISH

Your collar ties are now installed.

GABLE VENTS

PARTS REQUIRED:



x8 
1" (2,5 cm)



✓ **BEGIN**

1 Install (1) vent in each gable.

Caulk behind vent flanges.

Secure with 1" screws.

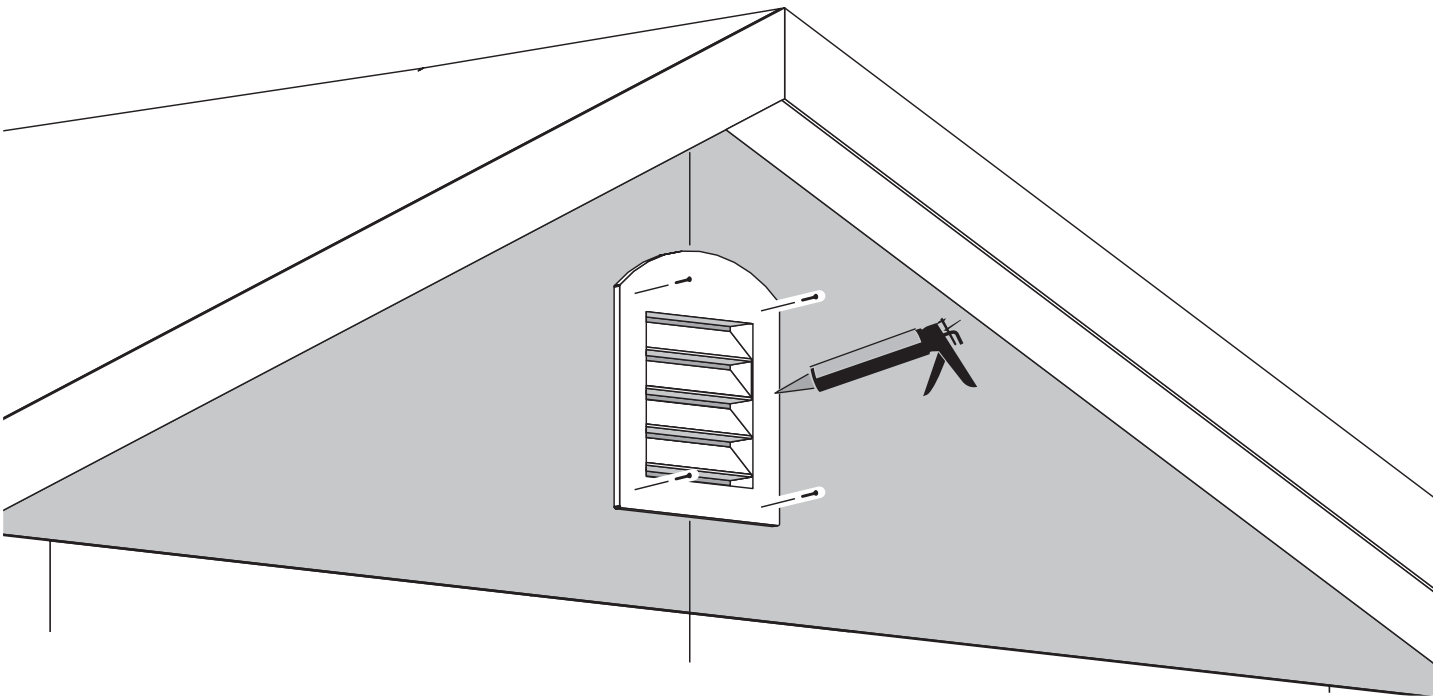

Your gable vents are installed.

PAINT & CAULK

- NOT INCLUDED -

PARTS REQUIRED:



- Use acrylic latex caulk that is paintable. Caulk at all horizontal and vertical seams, between the trim and walls, and all around the door trim.
- Use a high quality exterior acrylic latex paint. When painting your building, there are a few key areas that can be easily overlooked that must be painted:
 - Bottom edge of all siding and trim
 - Inside of doors and all 4 edges

Note:

Prime all un-primed exterior wood before painting.
(Follow directions provided by manufacturer.)

Building Size	Building Paint	Trim Paint	Caulk
12 x 8' (365,8 x 244,8 cm)	2 Gallons	1 Quart	3 Tubes

ROOF FELT

- NOT INCLUDED -

- Install felt flush to all roof edges overlapping 3". Use minimal amount of roofing nails to hold in place.

OK to overlap at ridge.

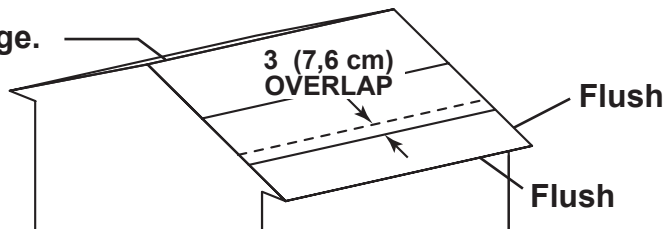

DRIP EDGE

- NOT INCLUDED -

- Install drip edge over roof felt on gable side and under roof felt on eave side (**Fig. A**).
- Do not use nails on side of drip edge that hangs over side of building.
- Only nail top of drip edge as shown.

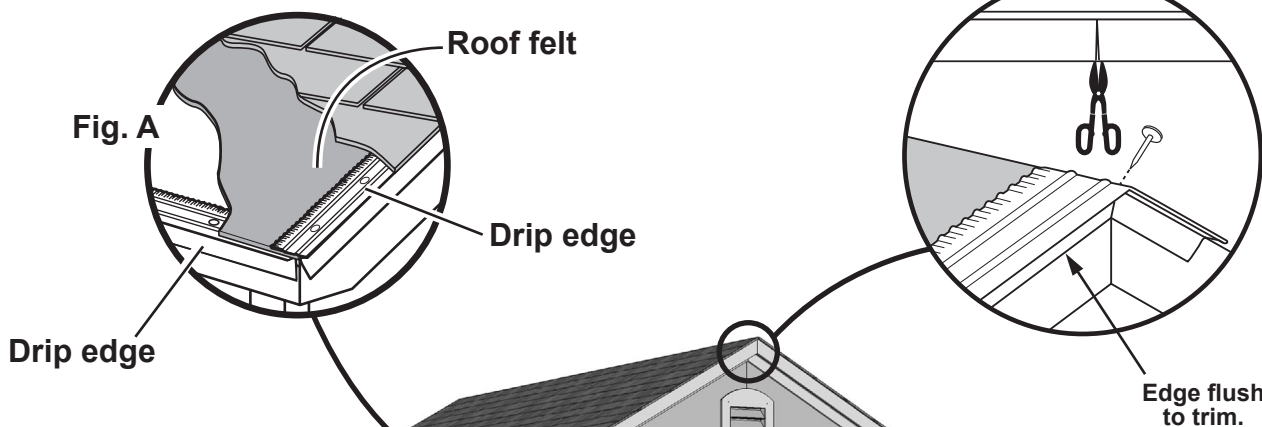

Snip bottom side of drip edge and bend over to other side of roof.

(Follow directions provided by manufacturer.)

Building Size	Drip Edge
12 x 8' (365,8 x 244,8 cm)	50' (15,2 m)

SHINGLES - NOT INCLUDED -

• Follow directions provided by manufacturer and these instructions.

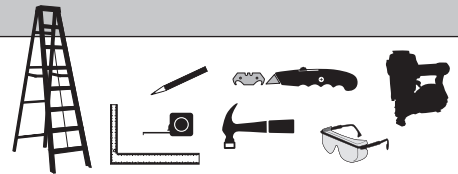

! Familiarize yourself with a 3-Tab Shingle.

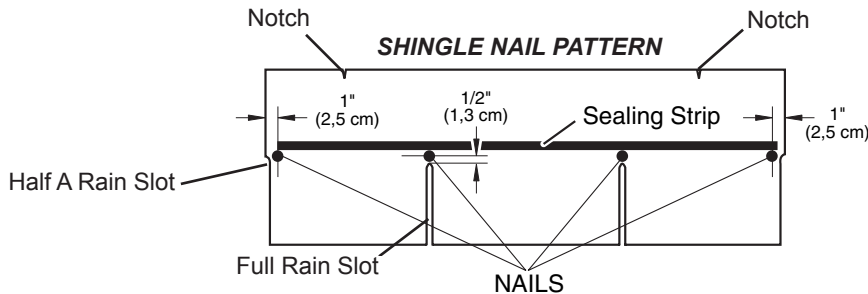

! NEVER DRIVE FASTENERS INTO OR ABOVE SEALING STRIPS.

✓ BEGIN

1 Install first starter row upside down and color up with a 1" overhang at back and bottom of roof panel. Use (4) nails per shingle. **Starter row must be straight and level all the way across with lower edge of roof deck.**

NOTE: If you have installed drip edge install shingles flush to drip edge.

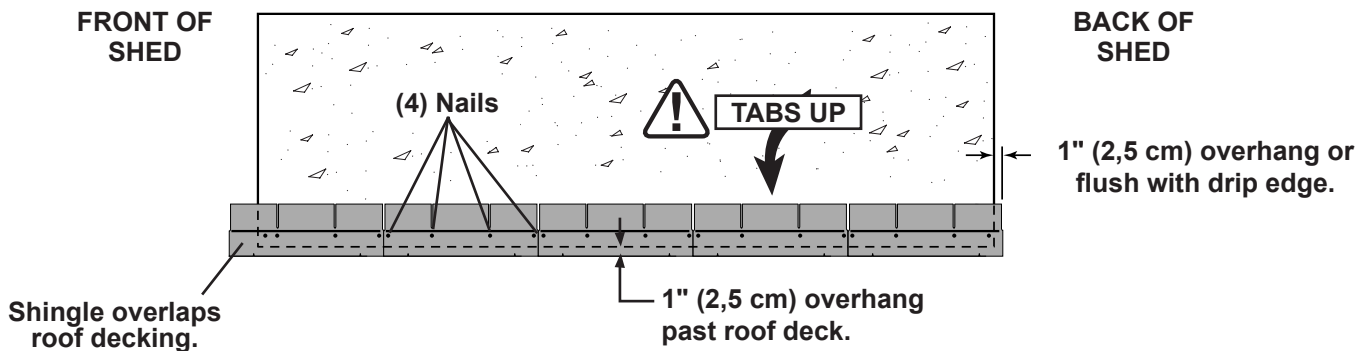

2 Beginning at front of shed, install first row of shingles with notch at 1" past roof edge or flush with drip edge.

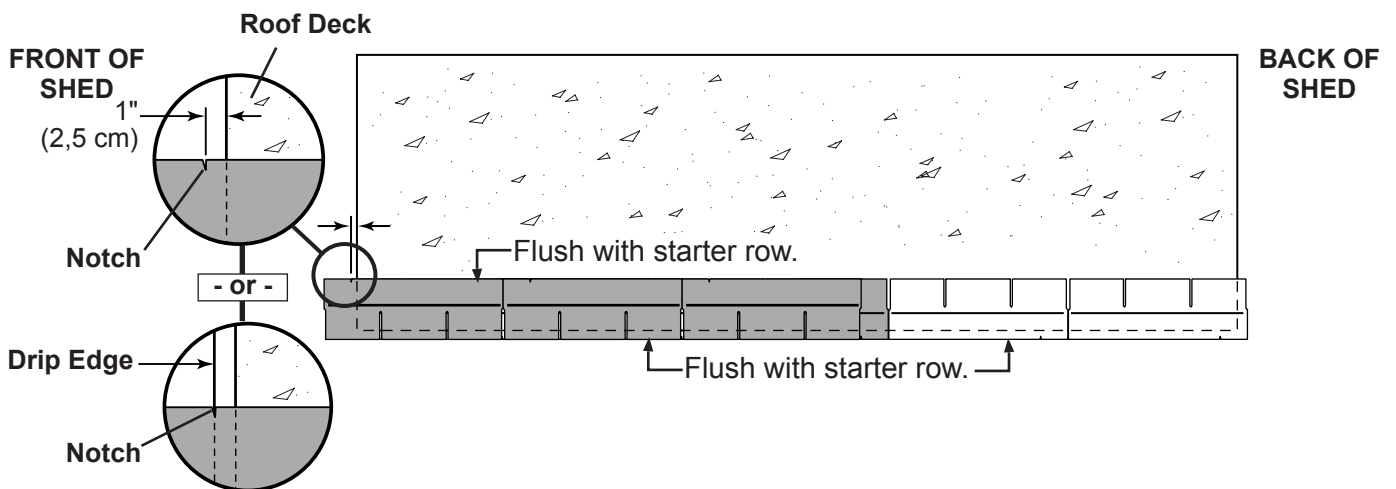

SHINGLES continued...

- 3** Install second row of shingles flush at top of first row's rain slots. Ensure 1" overhang or flush to drip edge at front, stagger each row.

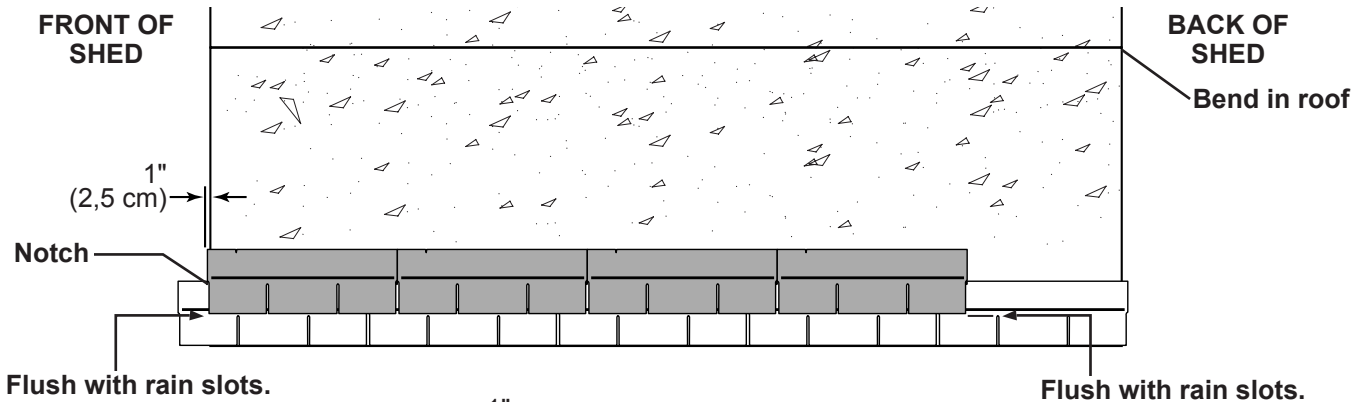

- 4** Continue installing rows of shingles by staggering at front.

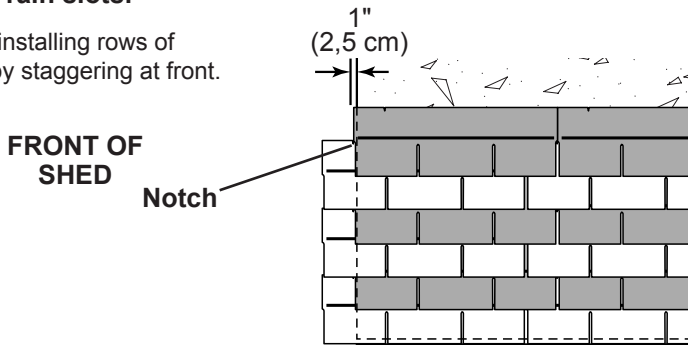

- 5** The shingle over the bend in the roof will be nailed down. You will need 3" to 4" of this shingle to extend downward over the bend for nailing.

Look for either of the following:

- If the rain slot of the shingle installed over the bend is ABOVE the bend and 3" to 4" of it overhangs down over the bend, continue shingling up to the peak. You have enough to nail shingle down over the bend.

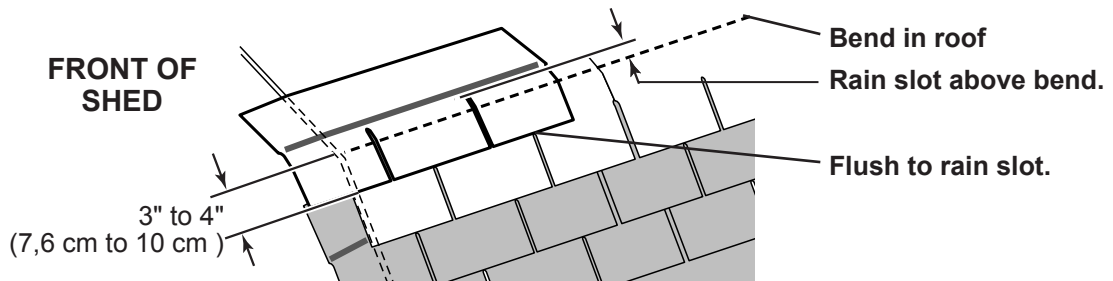

- OR -

- If the rain slot of the shingle installed over the bend is BELOW the bend, install the shingle over the bend and overlap the rain slot to get the 3" to 4" overlap.

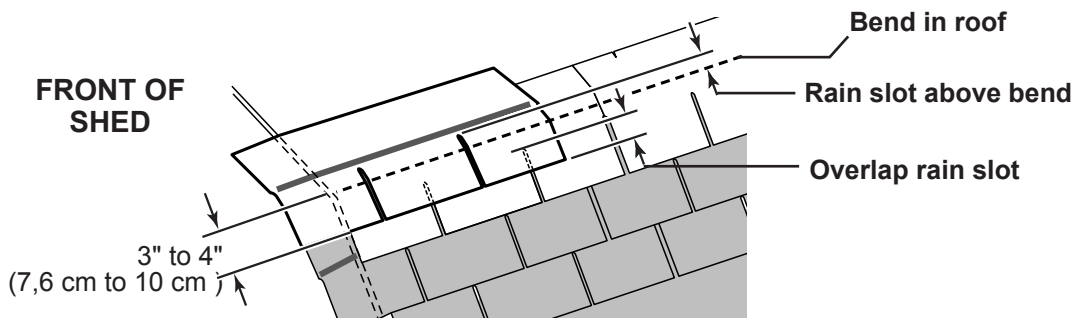

! The shingle OVER the bend must be installed with a 3" to 4" overlap **AND** the rain slot above the bend.

SHINGLES continued...

- 6 After shingles are installed over bend, nail down overlap with two roofing nails per tab.

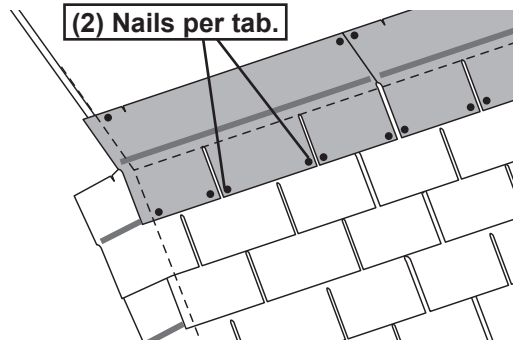

- 7 Continue installing rows of shingles to the peak. At the peak make sure there is a maximum of 5" or less to the rain slot, as shown below. If shingles overlap at ridge cut to peak using a utility knife.

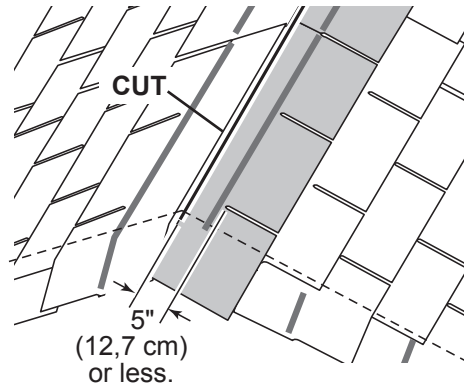
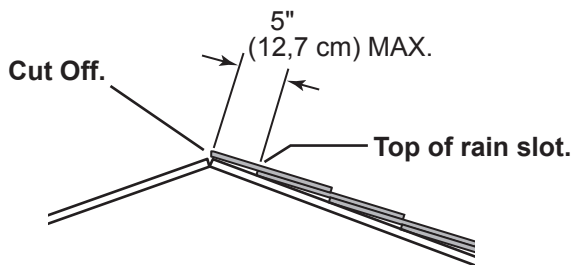

- ⚠ • If more than 5" to rain slot you must install another row of shingles.

- 8 Repeat steps 1 - 7 to shingle the opposite side of your roof. Trim shingles at ridge.

- 9 Once both sides are shingled you need to trim ends. Strike a chalk line 1" from edge.

- 10 Using your shingle hooked blade carefully cut shingles along chalk line.

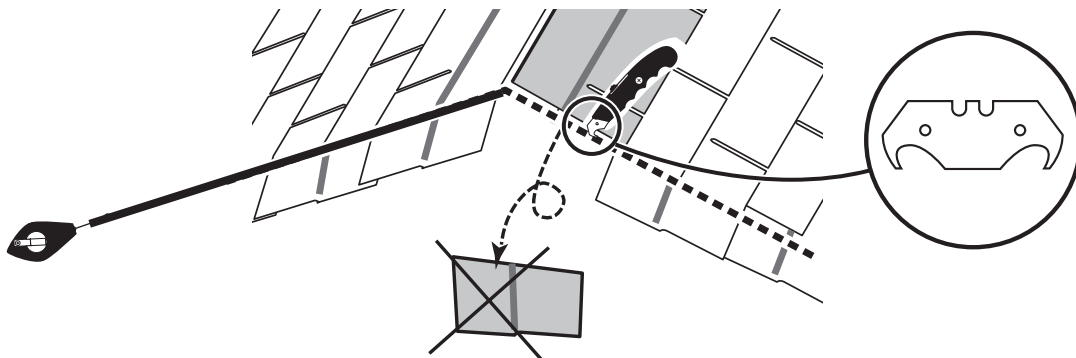

You have finished shingling your roof. Proceed to capping the ridge.

SHINGLES - RIDGE CAP



• You will finish off the top of the roof with a ridge cap made from shingles.

✓ **BEGIN**

1 Cut shingles into THREE pieces. **Hint:** Use cut-off pieces first.

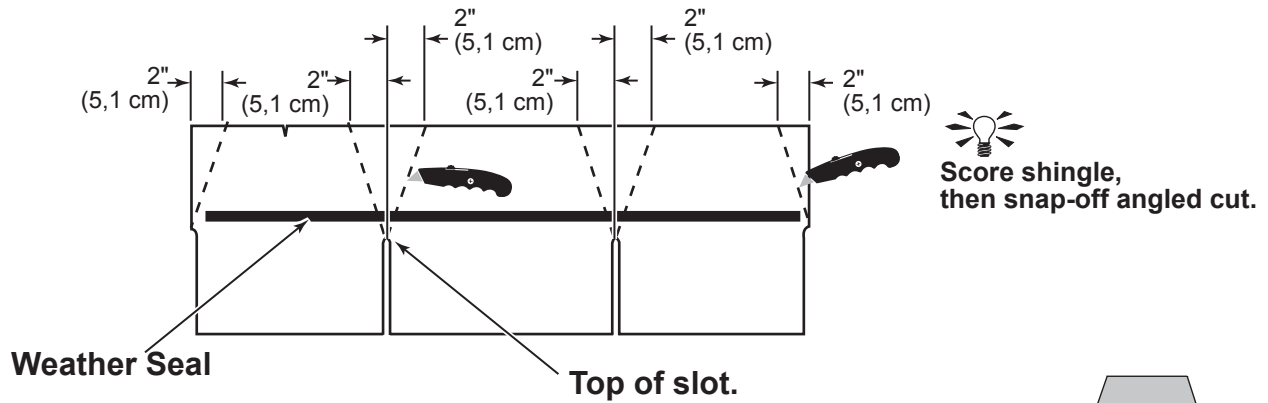

2 Install first ridge cap flush to shingles at front, as shown.

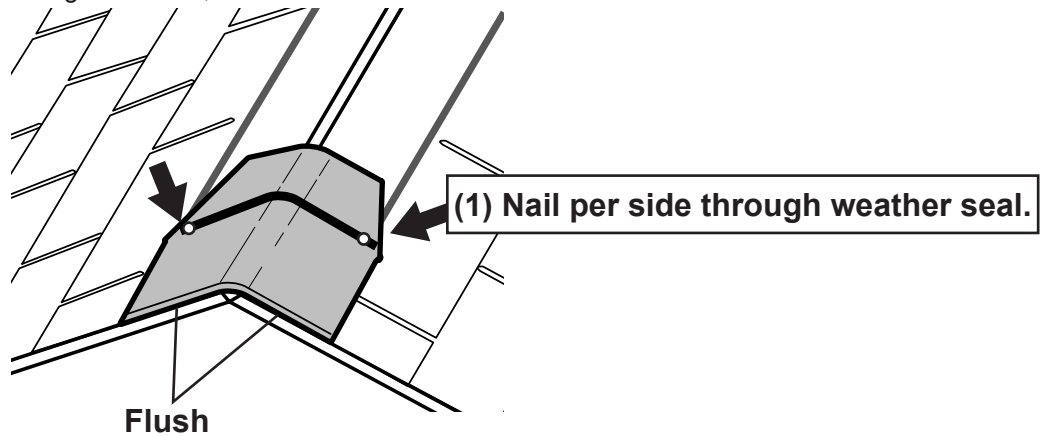

3 Install second ridge cap 5" back, as shown.

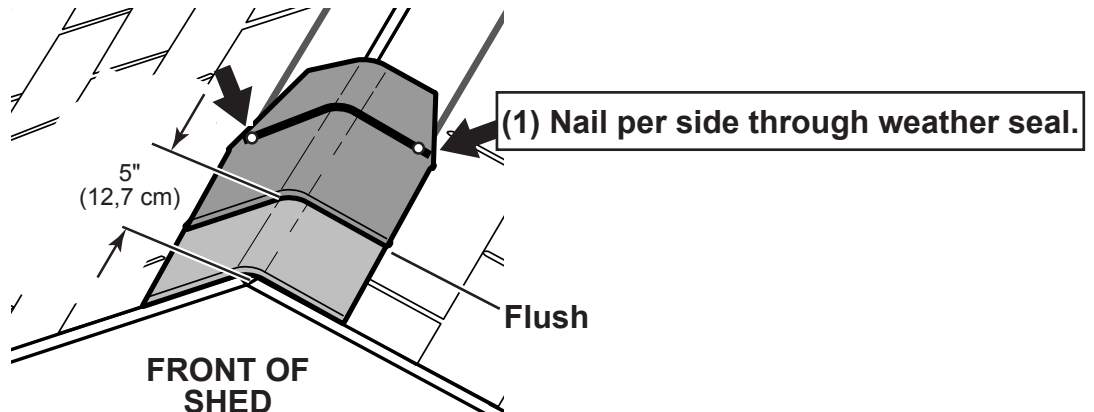

SHINGLES - RIDGE CAP

continued...

4 Continue installing ridge cap to back of roof.

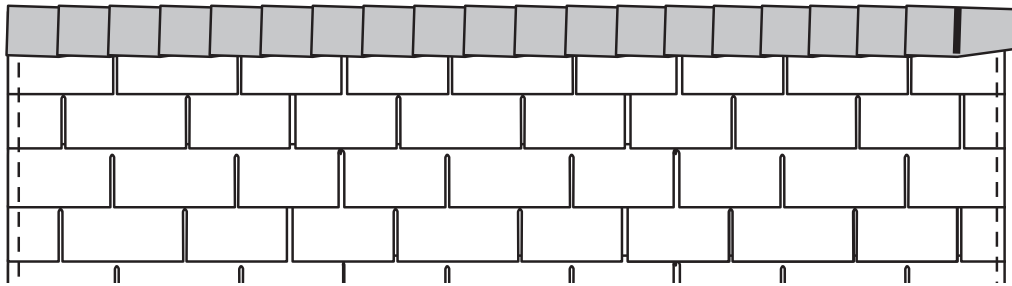

5 Make sure there is 4" (10,2 cm) between the shingle-color and edge of shingles.

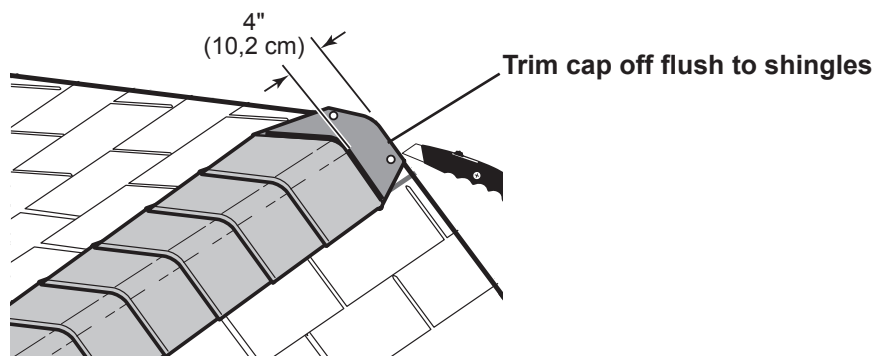

6 When you have 4" minimum of shingle color cut one piece to cap your roof.

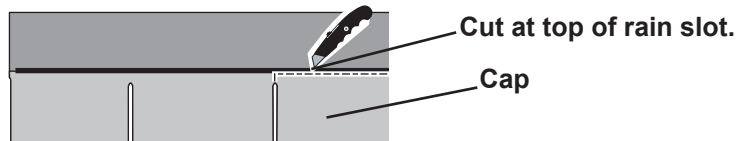

7 Install flush to shingles.

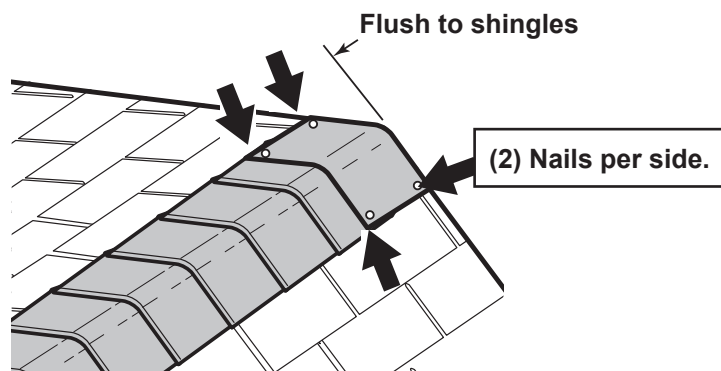

You have finished your ridge cap.

16698 Meridian 8' x 12' Gable Order Form

CATEGORY	PART DESCRIPTION	PART SIZE	PART ITEM #	BUILDING QTY.	PART ID
2 X 4	Wall Studs / Side Wall Top / Bottom	*LUM SPF 2X4X72 #2&BTR	O 7200000000	25	TM
	Plate "A"	LUM SPF 2X4X96 #2&BTR	12306	2	TP
	Gable End Top Plates	*2 X 4 X 89" PLATE	O 8900000000	4	SZ
	Plate "B"	2X4X48" DOUBLER/ PLATE/ CRATE	O 4800000000	2	SP
	Gable Connector	2 X 4 X 7"	O 0700000000	4	AL
	Jack Stud	2 X 4 X 68-1/2"	O 6808000000	2	YFA
	Header	2 X 4 X 51" PLATE	O 5100000000	2	TCA
	Gable Overhang	*2 X 4 X 62-3/16" 30" O/E ON FLAT / OVERHANG	O 6203300000	4	NXC
	Rafters	2 X 4 X 55-9/16" L/S 30" B/E	O 5509303000	14	TZA
2 X 6	Fascia Overhang "A"	LUM WSPF 2X6X96 #1 PREMIUM PET	12416	2	VX
	Fascia Overhang "B"	2 X 6 X 49 1/2" OVERHANG	N 4908000000	2	AS
1 X 3 PINE	Gauge Block	1 X 3 X 5" PINE FILLER	U 0500000000	1	GAA
1 X 4 PINE	Collar Tie	1 X 4 X 60" PINE COLLAR TIE	T 6000000000	2	JF
7/16 OSB	Roof Panel "A"	OSB 7/16" x 4' x 8'	11110	2	---
	Roof Panel "B"	7/16" OSB 47 7/8" X 48" ROOF	C 48004714000	2	---
	Roof Panel "C"	7/16" OSB 13-7/8" X 96" ROOF	C 96001314000	2	---
	Roof Panel "D"	7/16" OSB 13-7/8" X 48" ROOF PANEL	C 48001314000	2	---
	Header Filler	7/16" OSB 3 1/4" X 50 3/4"	C 50120304000	1	---
GUSSETS	Gusset	EZ 8" 6" X 24" GUSSET 28*-	J 24000600280	12	---
NO GROOVE SIDING	Wall Panel	SIDING NGSE 3/8X4X76"	11501	8	---
	Side Wall Panel	3/8" NG 23 7/8" X 76"	K 76002314000	2	---
	Over Door Panel	3/8" NG 3-7/8" X 48" OVER DOO	K 48000314000	1	---
	Right Gable Panel w/ Window	3/8" NG 31-1/2" X 48" RGT GABLE PANEL w/ VENT HOLE	K 48003108144	2	---
	Left Gable Panel w/ Window	3/8" NG 31-1/2" X 48" LFT GABLE PANEL w/ VENT HOLE	K 48003108244	2	---
Corner Trim	3/8" NG 1 3/4" X 75-3/4" CORN	K 75120112000	8	---	
19/32 X 3 SMART TRIM	Horizontal Door Rails	19/32 TST 2 1/2" X 18-5/8" RAIL	UT18100208000	2	EGB
	Decorative Door Trim	19/32 TST 2 1/2" X 32" DOOR T	UT32000208000	2	UWA
	Gable Trim RIGHT	19/32 TST 2 1/2" X 63-1/16"	UT63010208100	2	YOR
	Gable Trim LEFT	19/32 TST 2 1/2" X 63-1/16"	UT63010208200	2	YOL
	Fascia "A"	19/32 TST 2 1/2" X 91"	UT91000208000	2	BSA
	Fascia "B"	*19/32 TST 2 1/2" X 62 3/4" SMT TRIM	UT62120208000	2	JUB
	Over Door Trim	19/32 TST 2 1/2" X 55" TRIM	UT55000208000	1	ZB
19/32 X 4 SMART TRIM	Frieze Board - Right	19/32 TST 3 1/2" X 62 3/16" 30" B/E RIGHT GABLE TRIM	UT62030308130	2	HUR
	Frieze Board - Left	19/32 TST 3 1/2" X 62 3/16" 30" B/E LEFT GABLE TRIM	UT62030308230	2	HUL
PURCHASED COMPONENTS	Door Stiffener	LSL 1-1/4 X 2-1/4 X 69 PET	12715	2	OO
	Single Point Locking Handle	HANDLE - T 5-1/2" SHAFT & "D"	15375	1	---
	Arched Vent	VENT 8X10, APL# CV12X18W-PE, A	15021	2	---
	Hardware Kit	H/K (MERIDIAN 8 X 10 & 8 X 12) COSTCO GABLE - 2 x 4	15778	1	---
	6d Nails	NAIL 6D 2" BOX HDG BOX	15105	4	---
	10d Nails	NAIL 10D 3" BOX HDG BOX	15109	3	---
PACKAGING	Instructions		16698	1	---
Right Door Assembly	30129-R				
	Door Panel	3/8" NG 23 3/8" X 71 1/2" DOOR PANEL	K 71082306000	1	---
	Right Hinge Assembly	HINGE RIGHT (RED) 19/32x3 THIN TRIM	30121-TT	1	---
	Vertical Door Stiles	19/32 TST 2 1/2" X 71 5/8"	UT71100208000	1	GY
Horizontal Door Rails	19/32 TST 2 1/2" X 18-5/8" RAIL	UT18100208000	2	EGB	
Left Door Assembly	30129-L				
	Door Panel	3/8" NG 23 3/8" X 71 1/2" DOOR PANEL	K 71082306000	1	---
	Left Hinge Assembly	HINGE LEFT (GREEN) 19/32x3 THIN TRIM	30131-TT	1	---
	Vertical Door Stiles	19/32 TST 2 1/2" X 71 5/8"	UT71100208000	1	GY
Horizontal Door Rails	19/32 TST 2 1/2" X 18-5/8" RAIL	UT18100208000	2	EGB	

LIMITED CONDITIONAL WARRANTY*

Backyard Storage Solutions, LLC warrants the following:

1. Every product is warranted from defects in workmanship and manufacturing for 1 year.
2. All accessories, hardware and metal components are warranted for 2 years.
3. All Oriented Strand Board (OSB) is warranted for 2 years
4. Siding and Trim is warranted for 15 years.
5. LP Prostruct® Flooring is warranted for 10 years
6. Cedar lumber is warranted for 15 years.
7. Preserved Pine is warranted for 10 years.
8. Redwood is warranted for 10 years.
9. Metal Roof is warranted for 25 years.

Backyard Storage Solutions, LLC will repair, replace or pay for the affected part. In no event shall Backyard Storage Solutions, LLC pay the cost of labor or installation or any other costs related thereto. All warranties are from date of purchase. If a cash refund is paid on an affected part, it will be prorated from the date of purchase.

CONDITIONS

The warranty is effective only when:

1. The unit has been erected in accordance with the assembly instructions.
2. The unit has been properly shingled and painted or stained and reasonably and regularly maintained thereafter.
3. The failure occurs when the unit is owned by the original purchaser.
4. Backyard Storage Solutions, LLC has received the warranty registration card within thirty (30) days of purchase and notification of the failure in writing within the warranty period specified above.
5. Backyard Storage Solutions, LLC has had reasonable opportunity during the sixty (60) days following receipt of notification to inspect and verify the failure prior to commencement of any repair work.

REQUIREMENTS

Storage Buildings

To validate your warranty, it is necessary to properly maintain your Backyard Storage Solutions, LLC unit; shingle the roof and paint or solid-colored stain the siding using quality, 100% acrylic latex exterior product with a minimum of two (2) coats within thirty (30) days of assembly; caulk above all doors and all horizontal and vertical trim boards; paint and seal all exposed edges, sides and faces of siding/trim and OSB siding to include all exterior walls and all sides and all edges of doors.

Gazebos & Pergolas

To validate your warranty, it is necessary to properly maintain your Backyard Storage Solutions, LLC unit. This includes treating all of the exposed cedar and pine surfaces on your gazebo or pergola structure with an exterior grade wood preservative, an exterior oil-based semi-transparent stain, an acrylic latex exterior paint or an acrylic latex solid color exterior stain within 30 days of assembly and as needed thereafter to maintain your warranty.

Keep vegetation trimmed away from building and make sure siding panels and trim do not come in contact with masonry or cement. The minimum ground clearance for siding must be one half inch (½ inch) from concrete slab or two and one half inches (2 ½”) from the ground when building is erected or constructed on a treated wood floor kit. Water from sprinklers must be kept off unit. In no event will Backyard Storage Solutions, LLC be responsible for any indirect, incidental, consequential or special damages nor for failure(s) that are caused by events, acts or omissions beyond our control including, but not limited to, misuse or improper assembly, improper maintenance (which eventually leads to rot or decay) and acts of God. Backyard Storage Solutions, LLC will not be held responsible for any labor costs incurred to construct your unit.

This warranty gives you certain specific rights that vary from state to state.

CLAIM PROCEDURE

To make a claim under this warranty, you can either call 1-888-827-9056 or email: customerservice@backyardproducts.com.

Please have ready the information below when you call or include the information in your email:

1. The model and size of the product.
2. A list of the part(s) for which the claim is made.
3. Proof of purchase of the Backyard Storage Solutions, LLC item, as shown on the original invoice or receipt.
4. Run code: found on exterior product label or assembly instructions enclosed in the product package.

All other inquiries can be mailed to:

Backyard Storage Solutions, LLC
Attn: Customer Service
1000 Ternes
Monroe, MI 48162

***WARRANTY TERMS MAY VARY OUTSIDE THE U.S.A.**

IMPORTANT: This is your warranty certificate.