

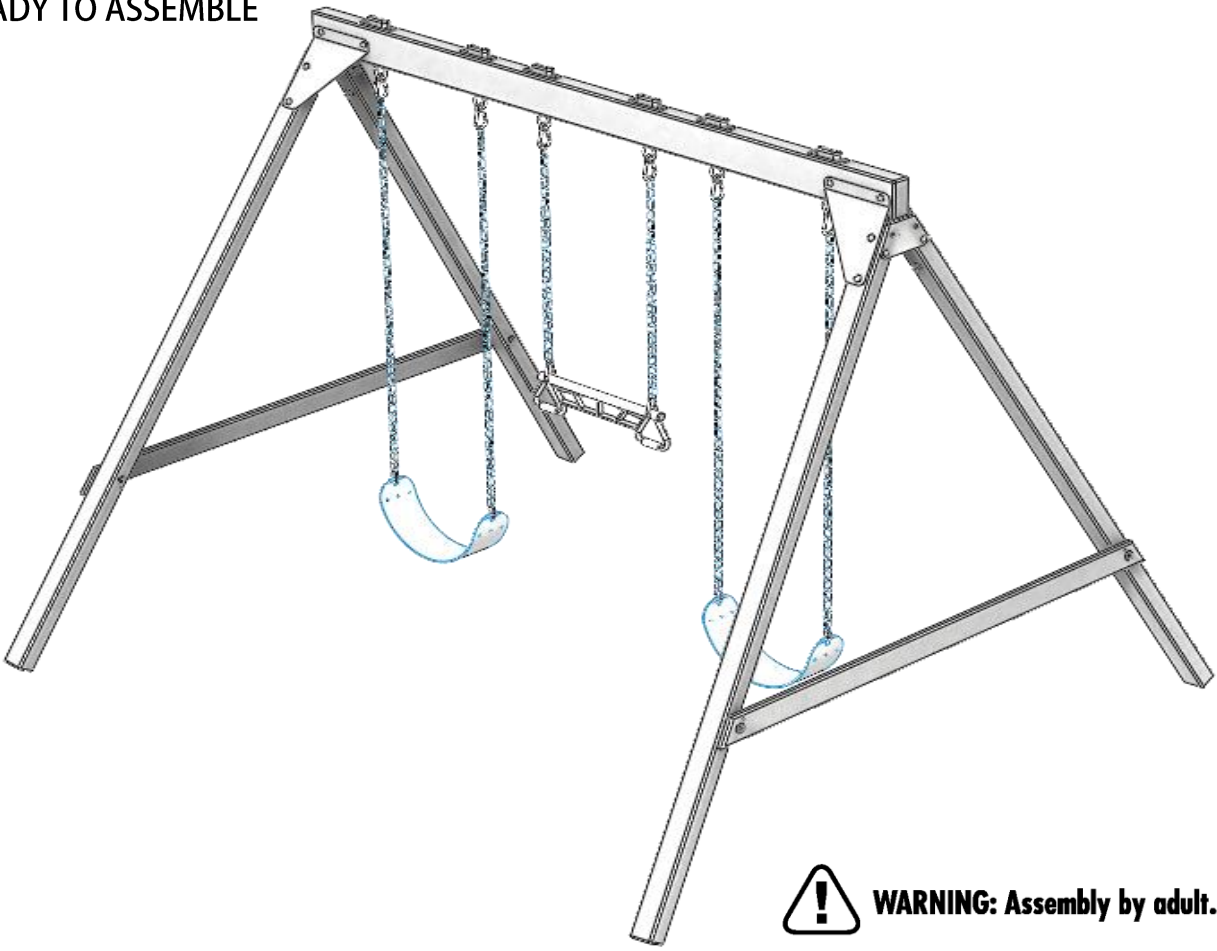

Model: PB 8360

WE PUT *Kids* FIRST!

READY TO ASSEMBLE



WARNING: Assembly by adult.



**FOR PRIVATE BACKYARD USE ONLY
DO NOT USE IN PUBLIC SETTINGS!**

IMPORTANT!!

PLEASE READ BEFORE BEGINNING ASSEMBLY!!

Please make sure all lumber, hardware and accessory parts are accounted for.
If you are missing anything, please **DO NOT RETURN** to the store where purchased.
Please call our Customer Service Department at the number below.

ASSEMBLY INSTRUCTIONS

Swing-N-Slide • 166 Etowah Industrial Ct. • Canton, GA 30114
Visit our website at: playsupport@backyardproducts.com or call us at 1-800-882-0272



Safety Checklist for Swing-N-Slide Play Sets and Accessories

Observing the following statements and warnings reduces the likelihood of serious or fatal injury

- This playset has been designed for use by a maximum of three occupants at one time having a combined weight of 345 pounds and maximum 115 pounds on each swing.
- This playset is intended for use by children from (2) to (10) years of age.
- On-site adult supervision for children of all ages is recommended.
- Instruct children not to walk close to, in front of, behind, or between moving items.
- Instruct children not to twist swing chains or ropes or loop them over the top support bar since this may reduce the strength of the chain or rope.
- Instruct children to avoid swinging empty seats.
- Teach children to sit in the center of the swings with their full weight on the seats.
- Instruct children not to use the equipment in a manner other than intended.
- Instruct children not to get off equipment while it is in motion.
- Do not allow children to wear inappropriate items, such as but not limited to, loose fitting clothing, hood and neck drawstrings, scarves, cord-connected items, capes and ponchos. These items can cause death by strangulation.
- Instruct children not to climb when the equipment is wet. Slippery surfaces may cause a hazard.
- Verify that suspended climbing ropes, chain, or cable are secured at both ends.
- Verify that suspended climbing ropes, chain, or cable cannot be looped back on itself.
- Instruct children not to attach items to the playground equipment that are not specifically designed for use with the equipment, such as, but not limited to, jump ropes, clothesline, pet leashes, cables and chain as they may cause a strangulation hazard.
- Instruct children to remove their bike or other sports helmet before playing on the playground equipment.
- Dress children with well-fitting and full foot enclosing footwear. Examples of inappropriate footwear are clogs, flip flops, and sandals.
- Instruct children to not walk or run up slides.
- Instruct children to not pick up slides or ramps as this may cause damage or breakage.
- Place the equipment on level ground not less than six (6) feet from any obstructions. Be sure to look overhead for any obstructions above the playset.
- Do not use the equipment until fully erected per this playset instruction manual, bolts tightened and the playset is anchored to the ground.

IMPORTANT!

This product is intended for single family home/residential use only and not intended for use in any public setting. Placement in any public setting constitutes a misuse of this product.

PLAYSET MAINTENANCE

Cosmetic defects that do not affect the structural integrity of the product, or natural defects of wood such as warping, splitting, checking, twisting, shrinkage, swelling or any other physical properties of wood that do not present a safety hazard, are not covered by our warranty.

To help minimize these natural defects we recommend applying a sealer or stain every two or three years, or more often as the climate dictates. Power washing, sanding or other preparatory methods should be used prior to sealing or staining.

Periodic maintenance is required to ensure safe enjoyment of your playset and accessories. Read and follow the Playset Checklist below to reduce the likelihood of serious or fatal injury. Use the checklists as a guide for proper playset care and maintenance.

PLAYSET CHECKLIST

At the beginning of each play season:

- Tighten all hardware.
- Lubricate all metallic moving parts per manufacturer's instructions.
- Check all protective coverings on bolts, pipes, edges, and corners. Replace if they are loose, cracked, or missing.
- Check all moving parts including swing seats, ropes, cables, and chains for wear, rust, or other deterioration. Replace as needed.
- Check metal parts for rust. If found, sand and repaint using a nonleaded-based paint meeting the requirements of 16 CFR 1303.
- Check all wood members for deterioration and splinters. Sand down splinters and replace deteriorating wood members.
- Reinstall any plastic parts, such as swing seats or any other items that were removed for the cold season.
- Rake and check depth of loose fill protective surfacing materials to prevent compaction and to maintain appropriate depth. Replace as necessary.

Twice a month during play season:

- Tighten all hardware.
- Check all protective coverings on bolts, pipes, edges, and corners. Replace if they are loose, cracked, or missing.
- Rake and check depth of loose fill protective surfacing materials to prevent compaction and to maintain appropriate depth. Replace as necessary.

Once a month during play season:

- Lubricate all metallic moving parts per manufacturer's instructions.
- Check all moving parts including swing seats, ropes, cables, and chains for wear, rust, or other deterioration. Replace as needed.

At the end of each play season or when the temperature drops below 10°F:

- Remove plastic swing seats, tents, sandbox cover, tire swing, slide and other items as specified by the manufacturer and take indoors or do not use.
- Rake and check depth of loose fill protective surfacing materials to prevent compaction and to maintain appropriate depth. Replace as necessary.
- Owner shall be responsible for maintaining the legibility of warning labels.

When you are ready to dispose of your playset, make sure that all metal, plastic and wood components are disposed of in accordance with local waste ordinances.

Buyer and/or owner should disassemble and dispose of the playground equipment in such a way that no unreasonable hazards will exist at the time the swing set is discarded. Do not burn your playset's preserved wood.

For further information on playground safety, the Consumer Product Safety Commission (CPSC) publishes the Outdoor Home Playground Safety Handbook which can be downloaded for free from www.cpsc.gov. An additional resource is the American Society of Testing and Materials (ASTM) Standard Consumer Safety Performance Specification for Home Playground Equipment (ASTM F1148) which can be purchased and downloaded from www.astm.org.

PLAYGROUND SURFACING MATERIALS

SECTION 4 OF THE CONSUMER PRODUCT SAFETY COMMISSION'S OUTDOOR HOME PLAYGROUND SAFETY HANDBOOK⁹

Select Protective Surfacing

One of the most important things you can do to reduce the likelihood of serious head injuries is to install shock-absorbing protective surfacing under and around your play equipment. The protective surfacing should be applied to a depth that is suitable for the equipment height in accordance with ASTM Specification F 1292. There are different types of surfacing to choose from; whichever product you select, follow these guidelines:

NOTE: Do not install home playground equipment over concrete, asphalt, or any other hard surface. A fall onto a hard surface can result in serious injury to the equipment user. Grass and dirt are not considered protective surfacing because wear and environmental factors can reduce their shock absorbing effectiveness. Carpeting and thin mats are generally not adequate protective surfacing. Ground level equipment - such as a sandbox, activity wall, playhouse or other equipment that has no elevated play surface - does not need any protective surfacing.

Maximum fall height for this playset is 75".

Loose-Fill Materials:

- Maintain a minimum depth of 9 inches of loose-fill materials such as wood mulch/chips, engineered wood fiber (EWF), or shredded/recycled rubber mulch for equipment up to 8 feet high; and 9 inches of sand or pea gravel for equipment up to 5 feet high. NOTE: An initial fill level of 12 inches will compress to about a 9-inch depth of surfacing over time. The surfacing will also compact, displace, and settle, and should be periodically refilled to maintain at least a 9-inch depth.
- Use a minimum of 6 inches of protective surfacing for play equipment less than 4 feet in height. If maintained properly, this should be adequate. (At depths less than 6 inches, the protective material is too easily displaced or compacted.)
- Use containment, such as digging out around the perimeter and/or lining the perimeter with landscape edging. Don't forget to account for water drainage.
- Check and maintain the depth of the loose-fill surfacing material. To maintain the right amount of loose-fill materials, mark the correct level on play equipment support posts. That way you can easily see when to replenish and/or redistribute the surfacing.
- Do not** install loose fill surfacing over hard surfaces such as concrete or asphalt.

Poured-In-Place Surfaces or Pre-Manufactured Rubber Tiles:

You may be interested in using surfacing other than loose-fill materials - like rubber tiles or poured-in-place surfaces.

- Installations of these surfaces generally require a professional and are not "do-it-yourself" projects.
- Review surface specifications before purchasing this type of surfacing. Ask the installer/manufacturer for a report showing that the product has been tested to the following safety standard: ASTM F 1292 Standard Specification for Impact Attenuation of Surfacing Materials within the Use Zone of Playground Equipment. This report should show the specific height for which the surface is intended to protect against serious head injury. This height should be equal to or greater than the fall height - vertical distance between a designated play surface (elevated surface for standing, sitting, or climbing) and the protective surfacing below - of your play equipment.
- Check the protective surfacing frequently for wear.

Placement

Proper placement and maintenance of protective surfacing is essential. Be sure to

- Extend surfacing at least 6 feet from the equipment in all directions.
- For to-fro swings, extend protective surfacing in front of and behind the swing to a distance equal to twice the height of the top bar from which the swing is suspended.
- For tire swings, extend surfacing in a circle whose radius is equal to the height of the suspending chain or rope, plus 6 feet in all directions.

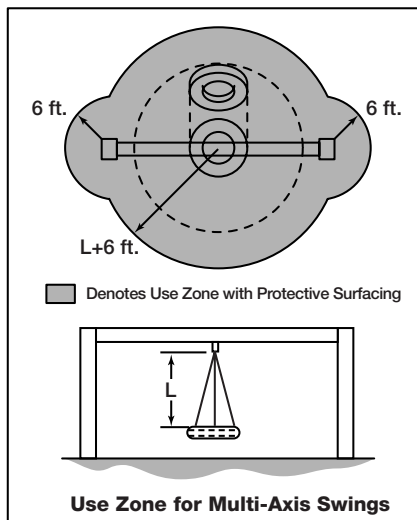
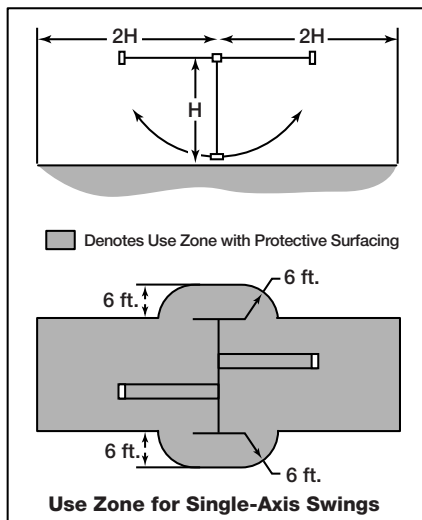

⁹ This information has been extracted from the CPSC publications "Playground Surfacing-Technical Information Guide" and "Handbook for Public Playground Safety." Copies of these reports can be obtained by sending a postcard to the: Office of Public Affairs, U.S. Consumer Product Safety Commission, Washington, D.C., 20207 or call the toll-free hotline: 1-800-638-2772

SAFETY ZONE & SWING WEIGHT SPECIFICATIONS

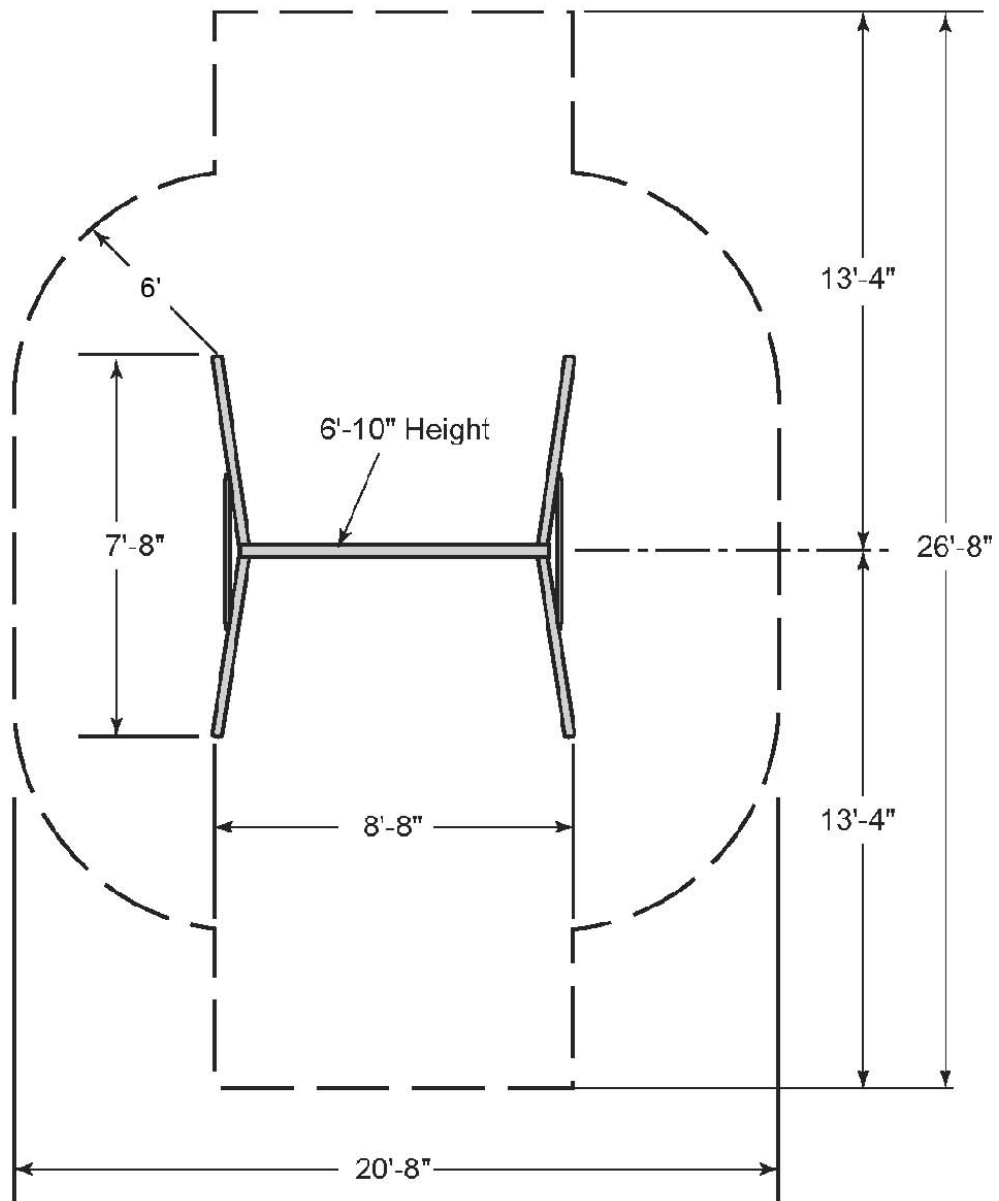

MINIMUM USE ZONE FOR PLAY EQUIPMENT SHALL EXTEND NO LESS THAN 72" FROM ALL SIDES OF THE PLAY STRUCTURE.

SWING USE ZONE EXTENDS NO LESS THAN 160".

SWINGS MUST HAVE A MINIMUM CLEARANCE OF 8" ABOVE THE PROTECTIVE SURFACING.



MAXIMUM OF 115 lbs. ON EACH SWING AND TRAPEZE

TOOLS REQUIRED



DRILL



1/2" & 9/16" SOCKETS & WRENCH



HAMMER

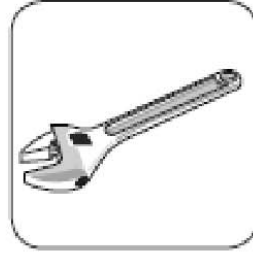

ADJUSTABLE WRENCH



TAPE MEASURE

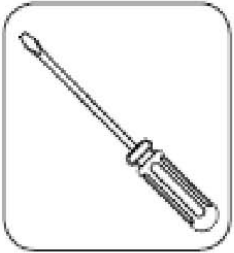

SCREWDRIVER



LADDER



SAFETY GLASSES

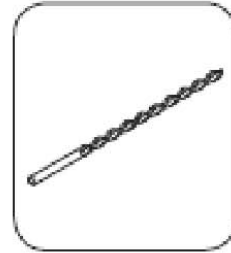

1/8" DRILL BIT



PLIERS

INCLUDED HARDWARE

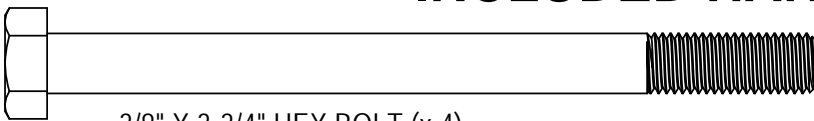

3/8" X 3-3/4" HEX BOLT (x 4)

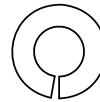

1/4" LOCK WASHER (x 4)

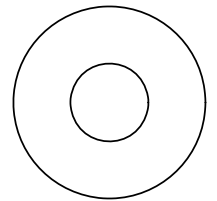

3/8" FLAT WASHER (x 26)

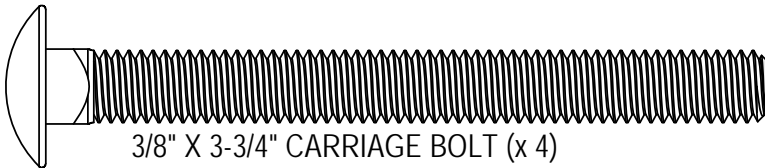

3/8" X 3-3/4" CARRIAGE BOLT (x 4)



TORX HEAD DRIVE (X2)
T-20 & T-30

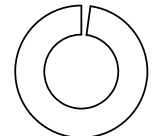

3/8" LOCK WASHER (x 6)

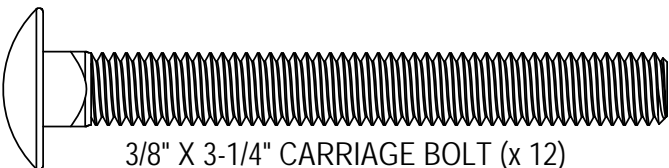

3/8" X 3-1/4" CARRIAGE BOLT (x 12)

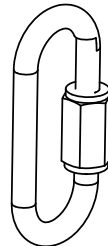

QUICK CLIP (x 4)

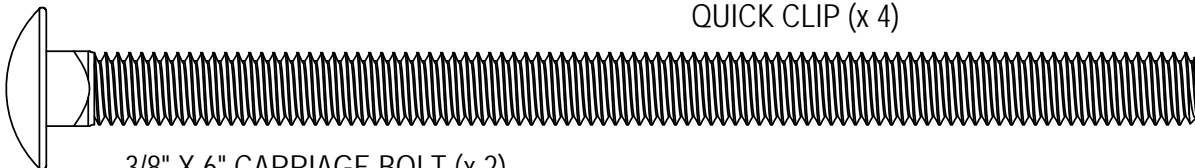

3/8" X 6" CARRIAGE BOLT (x 2)

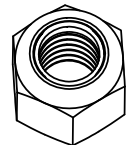

3/8" LOCK NUT (x 18)

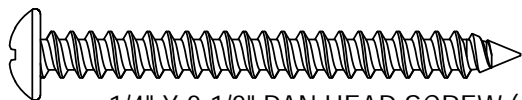

1/4" X 2-1/2" PAN HEAD SCREW (x 4)

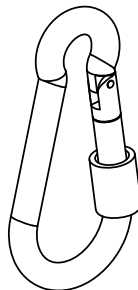

SPRING CLIP (x 2)

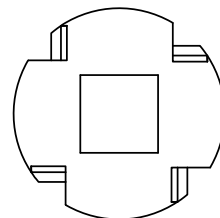

TORQUE WASHER (x 2)

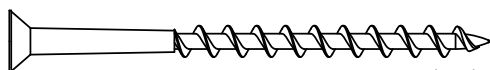

#8 X 2-1/2" WOOD SCREW (x 8)

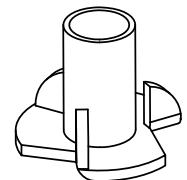

3/8" T-NUT (x 4)

COMPONENTS



PF 6090 2-3/8 X 5-1/8 X 87-1/2" SWING BEAM (x1)

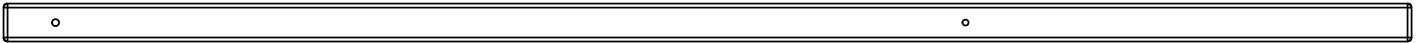

PF 6091 2-3/8 X 3 X 87-1/2" LEG (x4)

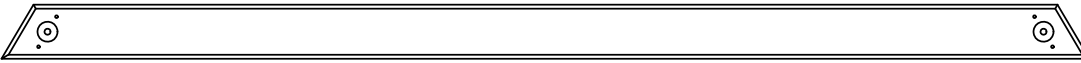

PF 6092 3/4" X 3-3/8" X 68" A-BRACE (x2)

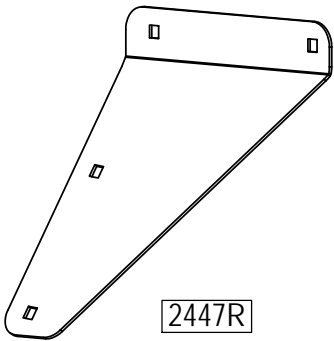

2447R

ANGLED BRACKET RIGHT
(x2)

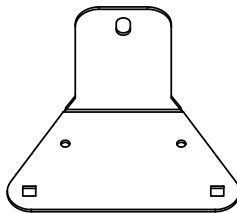

2449

L-BRACKET
(x2)

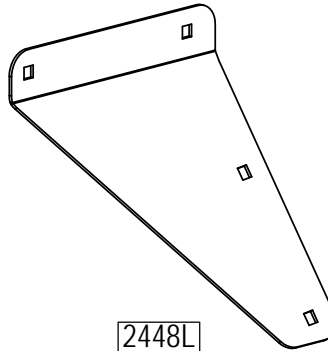

2448L

ANGLED BRACKET LEFT
(x2)

FS 2911

SPACER
(LOCATED
IN SA 2675
HARDWARE
BAG)

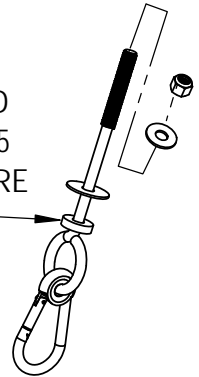

WS 4456

SWING HANGER
(x6)



SA 1699

PLAYSET PLAQUE (x1)
HARDWARE
INCLUDED



SA 4294

SAFETY PLATE (x1)
HARDWARE
INCLUDED

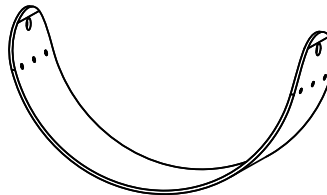

2434 SWING

(x2)

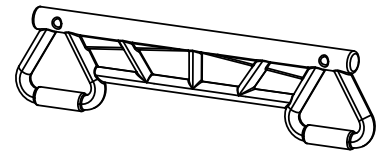

2096 TRAPEZE

(x1)



48" COATED CHAIN
(x4)



24" COATED CHAIN

(x2)

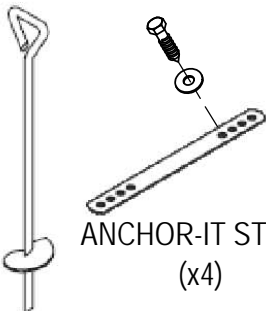

ANCHOR-IT STRAP
(x4)

ANCHOR-IT
(x4)

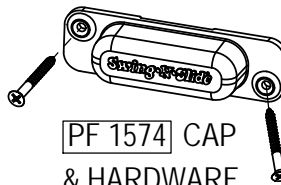

PF 1574 CAP
& HARDWARE

(x6)



INSTRUCTIONS BOOKLET

STEP 1: A-BRACE

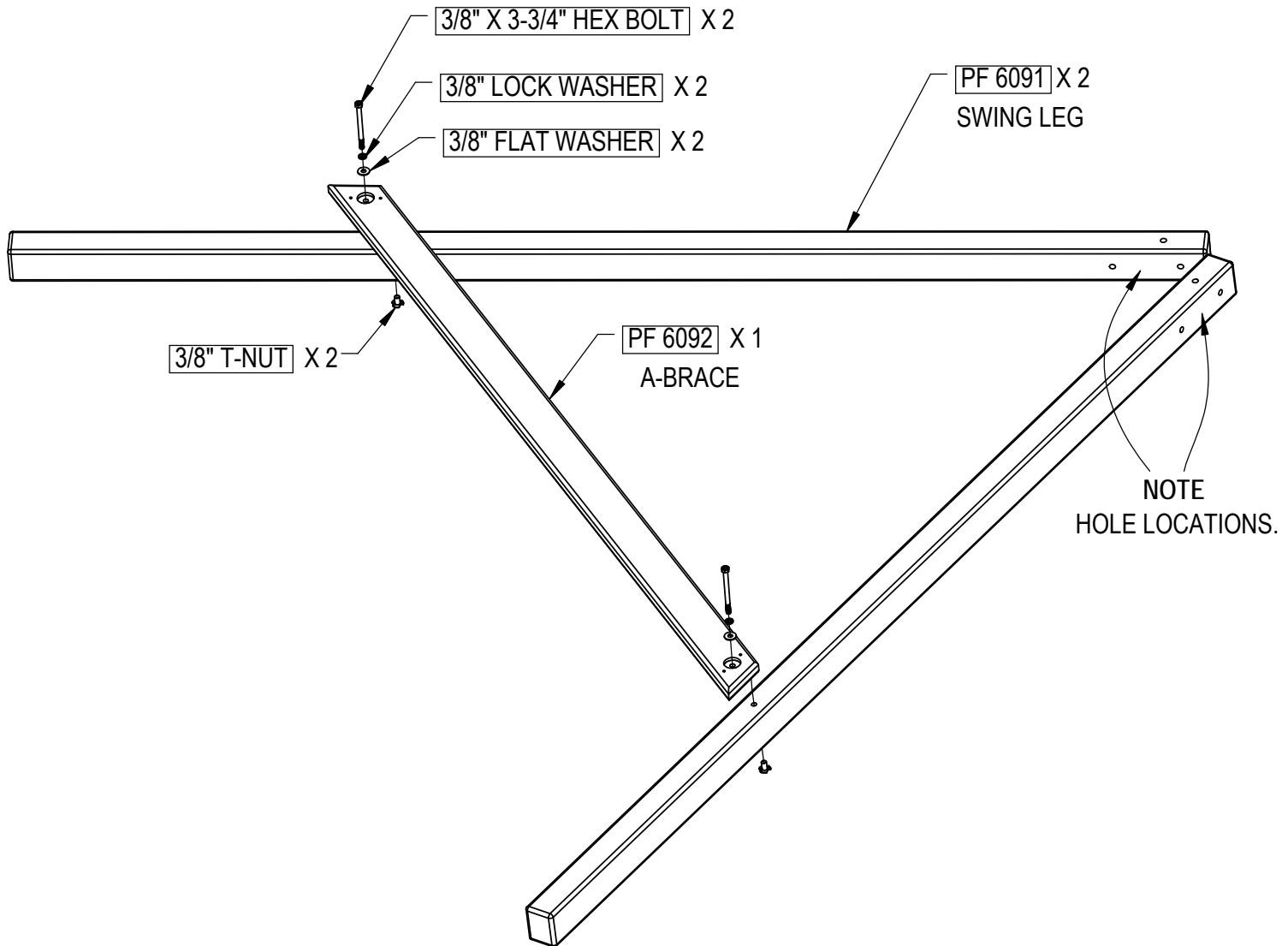

YOU WILL ASSEMBLE TWO A-FRAME POST ASSEMBLIES.

1. MOVE POSTS APART AND LOCATE AND ATTACH A-BRACE INTO PRE-DRILLED HOLES.

⚠ DO NOT FULLY TIGHTEN BOLTS AT THIS TIME.

STEP 2: L-BRACKET

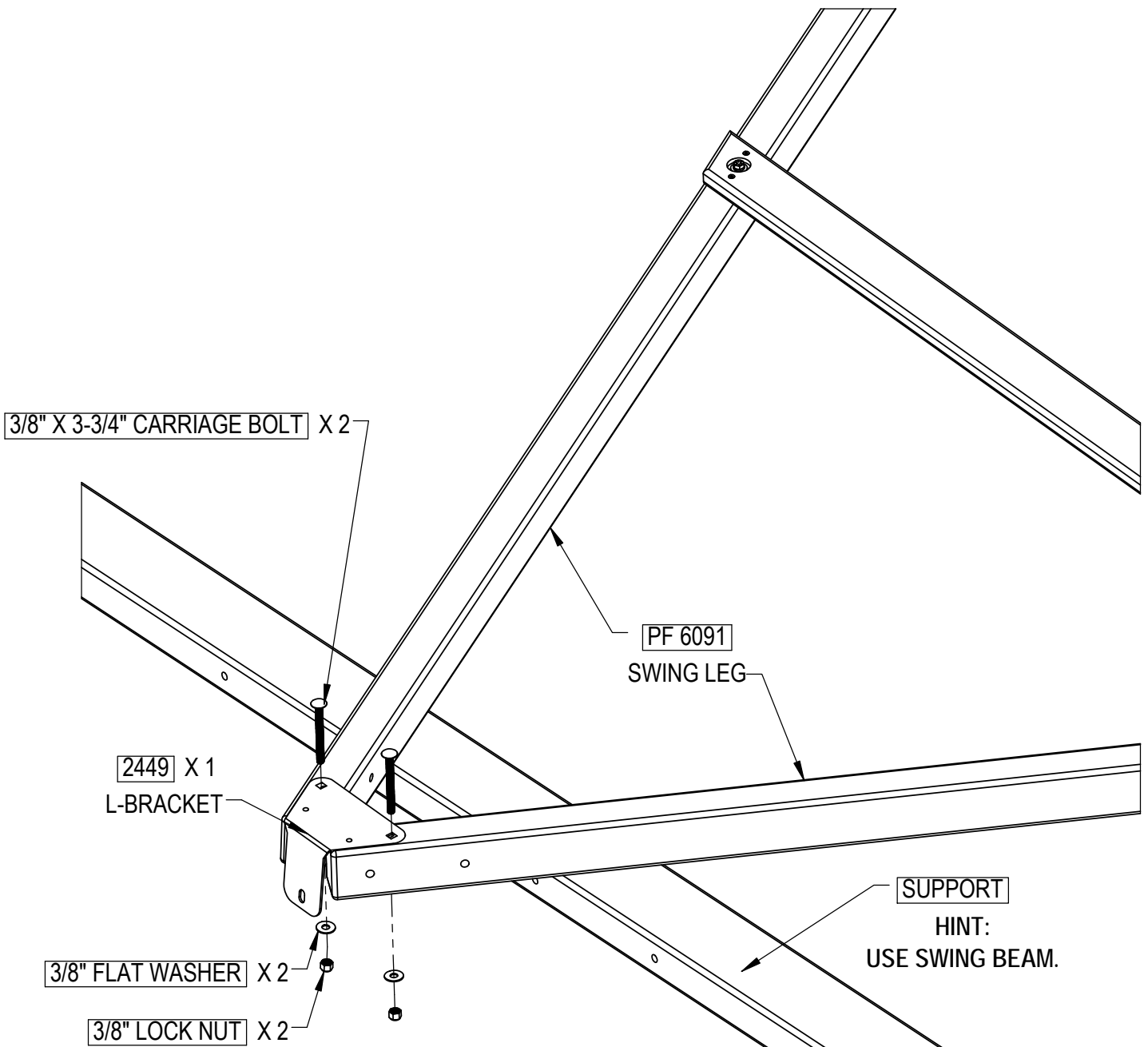

1. USE A TEMPORARY SUPPORT UNDER ENDS AND CAREFULLY SWING POST TOGETHER UNTIL EDGES TOUCH.

 **DO NOT FULLY TIGHTEN CARRIAGE BOLTS AT THIS TIME.**

STEP 3: A-FRAME ANGLED BRACKETS

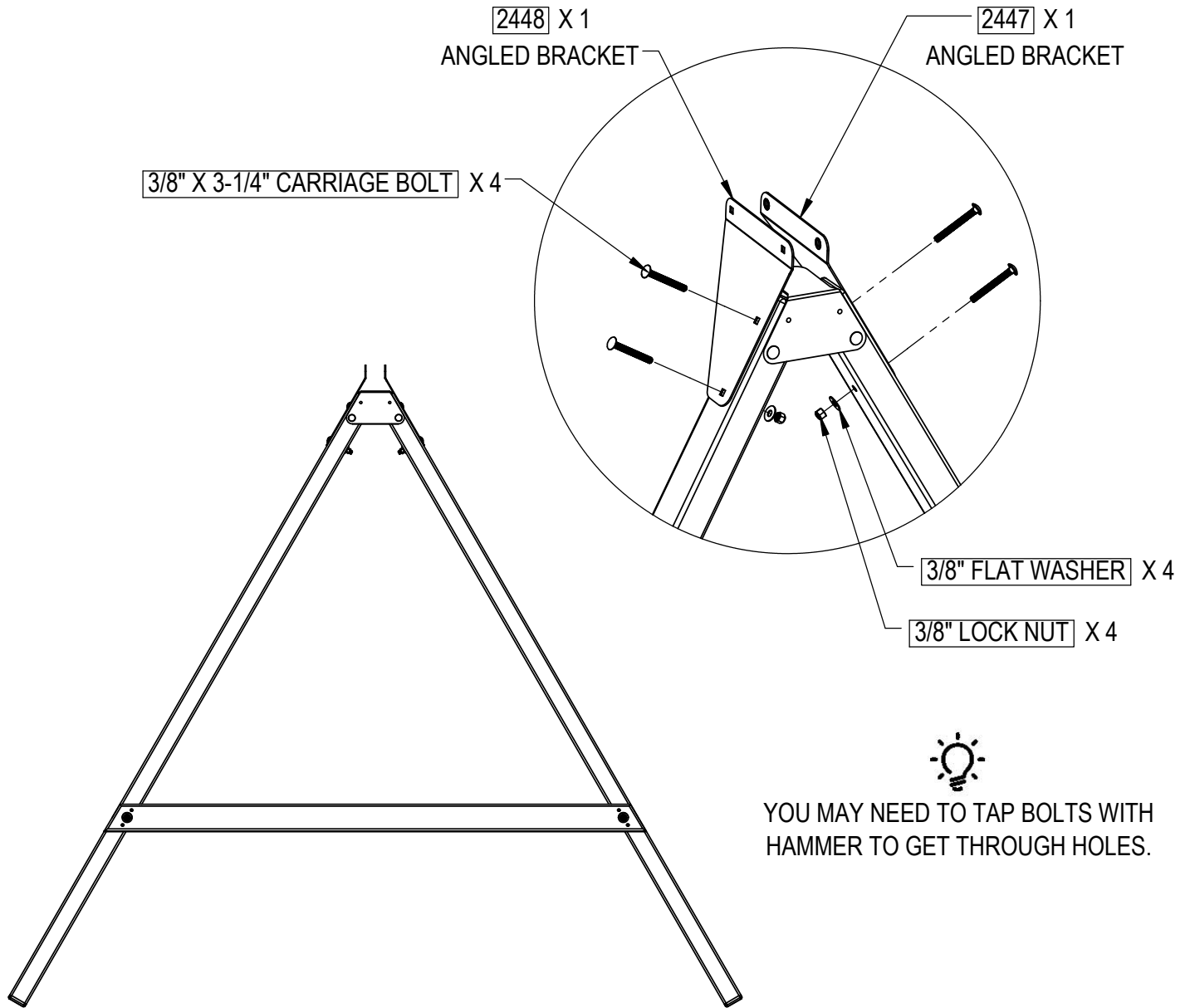

1. ATTACH ANGLED BRACKETS ON A-FRAME ASSEMBLIES.



DO NOT FULLY TIGHTEN CARRIAGE BOLTS AT THIS TIME.

STEP 4: SWING HANGERS

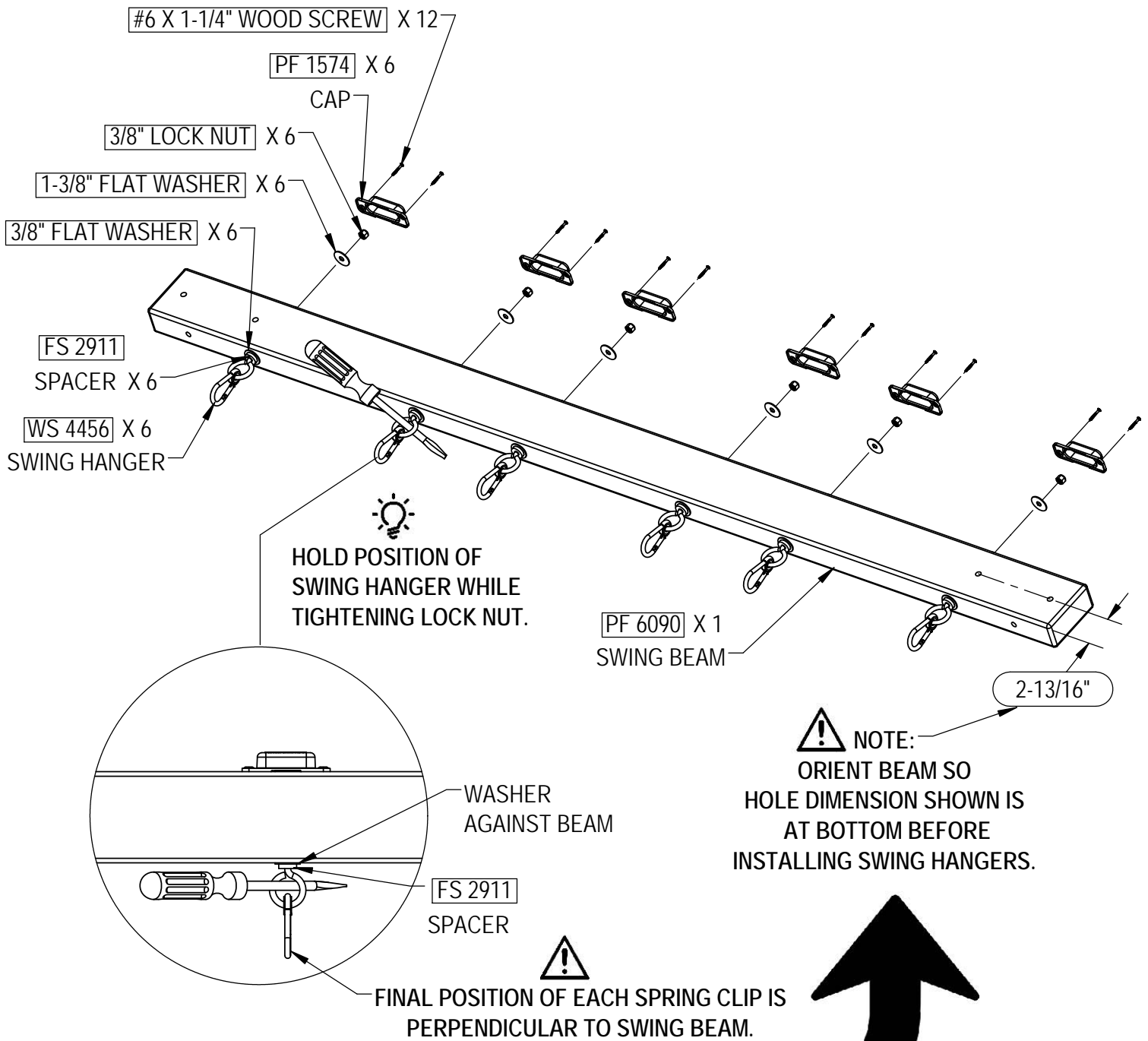

1. NOTE: THRU HOLES LOCATIONS.
2. INSTALL SWING HANGERS TO SWING BEAM.
3. FULLY TIGHTEN ALL BOLTS AND INSTALL PLASTIC CAP AS SHOWN.

STEP 5: SWING BEAM ASSEMBLY

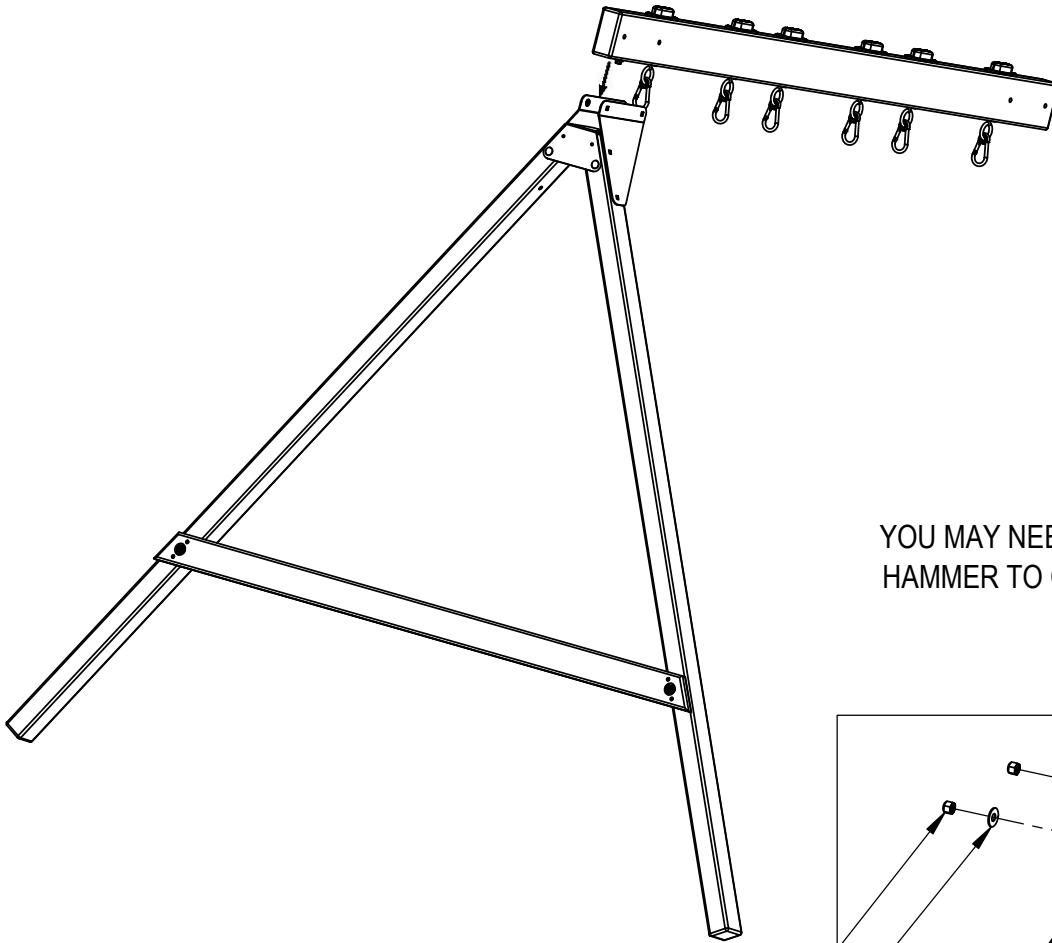

YOU MAY NEED TO TAP BOLTS WITH HAMMER TO GET THROUGH HOLES.

3/8" LOCK NUT X 2

3/8" FLAT WASHER X 2

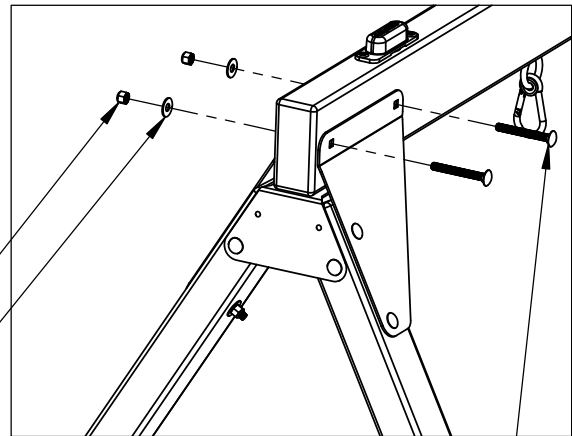

3/8" X 3-1/4" CARRIAGE BOLT X 2

1. POSITION SWING BEAM ASSEMBLY RESTING UPON ONE A-FRAME ONLY.
2. ALIGN HOLES AND INSERT CARRIAGE BOLTS.

⚠ DO NOT FULLY TIGHTEN CARRIAGE BOLTS AT THIS TIME.

STEP 6: SWING BEAM ASSEMBLY



YOU MAY NEED TO TAP BOLTS WITH HAMMER TO GET THROUGH HOLES.

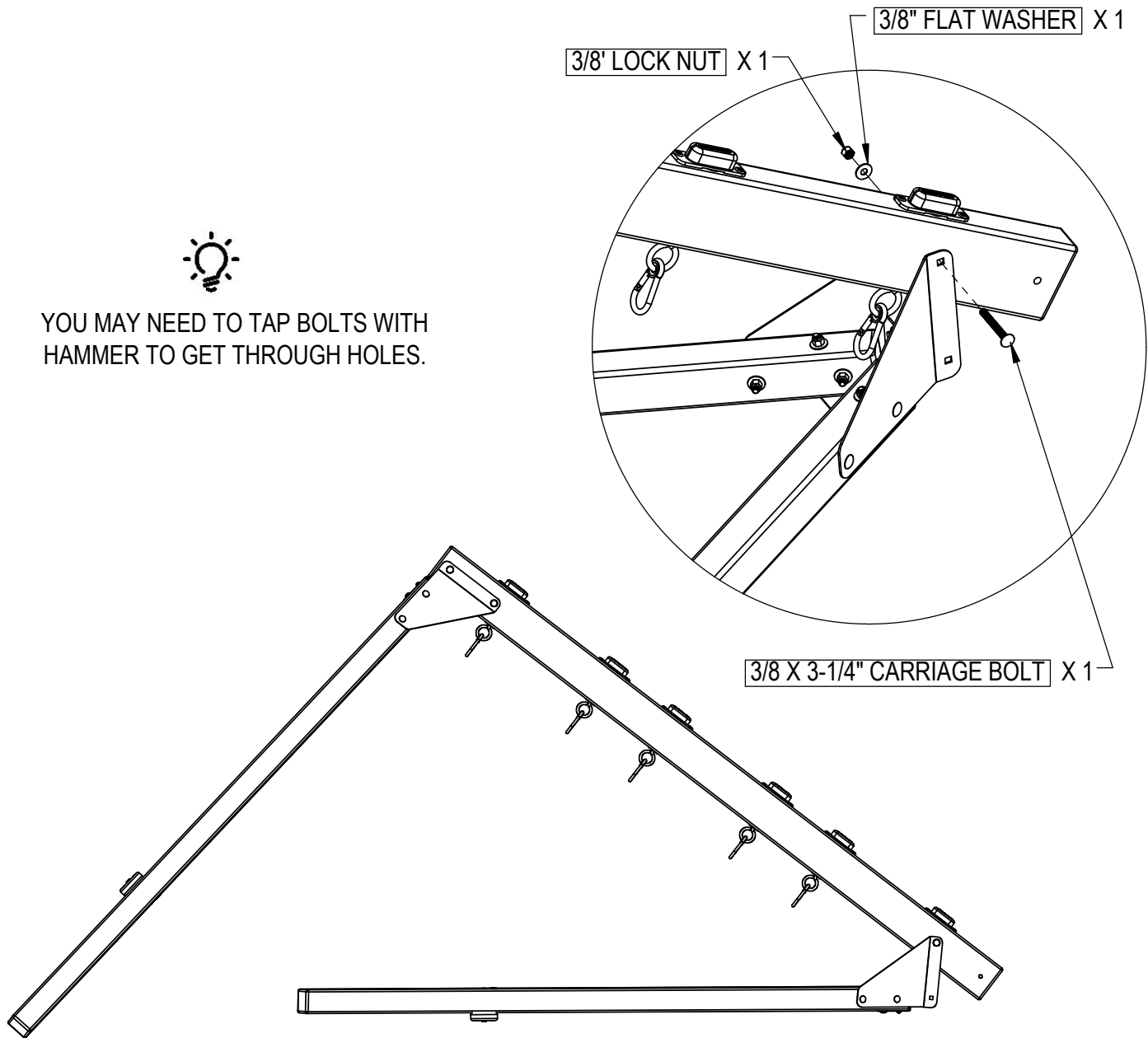

1. LAY A-FRAME ON THE GROUND WITH ANGLED BRACKETS FACING UP.
2. POSITION SWING BEAM ASSEMBLY RESTING UPON A-FRAME.
3. ALIGN HOLES AND INSERT CARRIAGE BOLT.

 **DO NOT FULLY TIGHTEN CARRIAGE BOLT AT THIS TIME.**

STEP 7: LIFTING SWINGSET

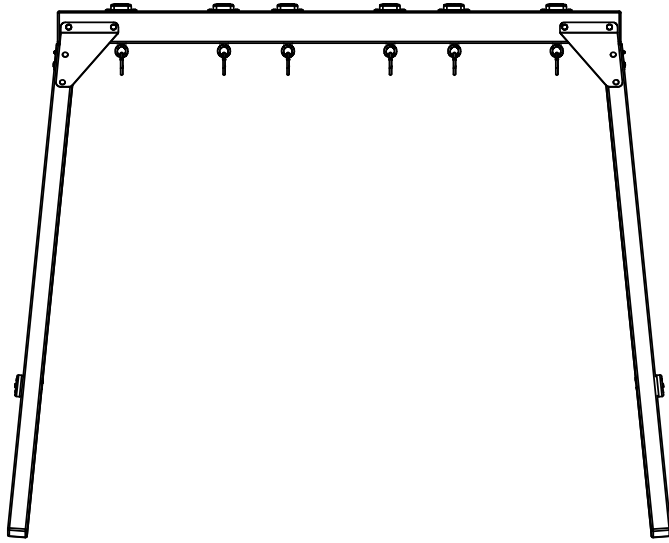

SWING A-FRAME UP.

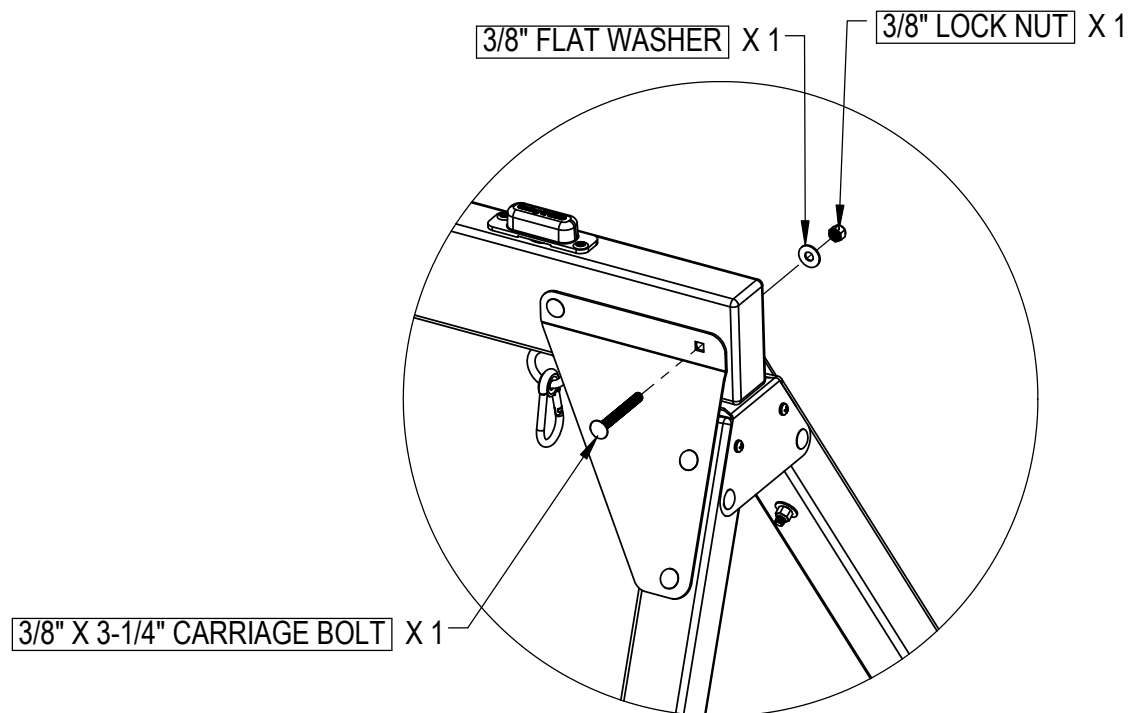

1. SWING A-FRAME UP AND INSERT SECOND BOLT.



DO NOT FULLY TIGHTEN CARRIAGE BOLT AT THIS TIME.

STEP 8: FINAL POSITION

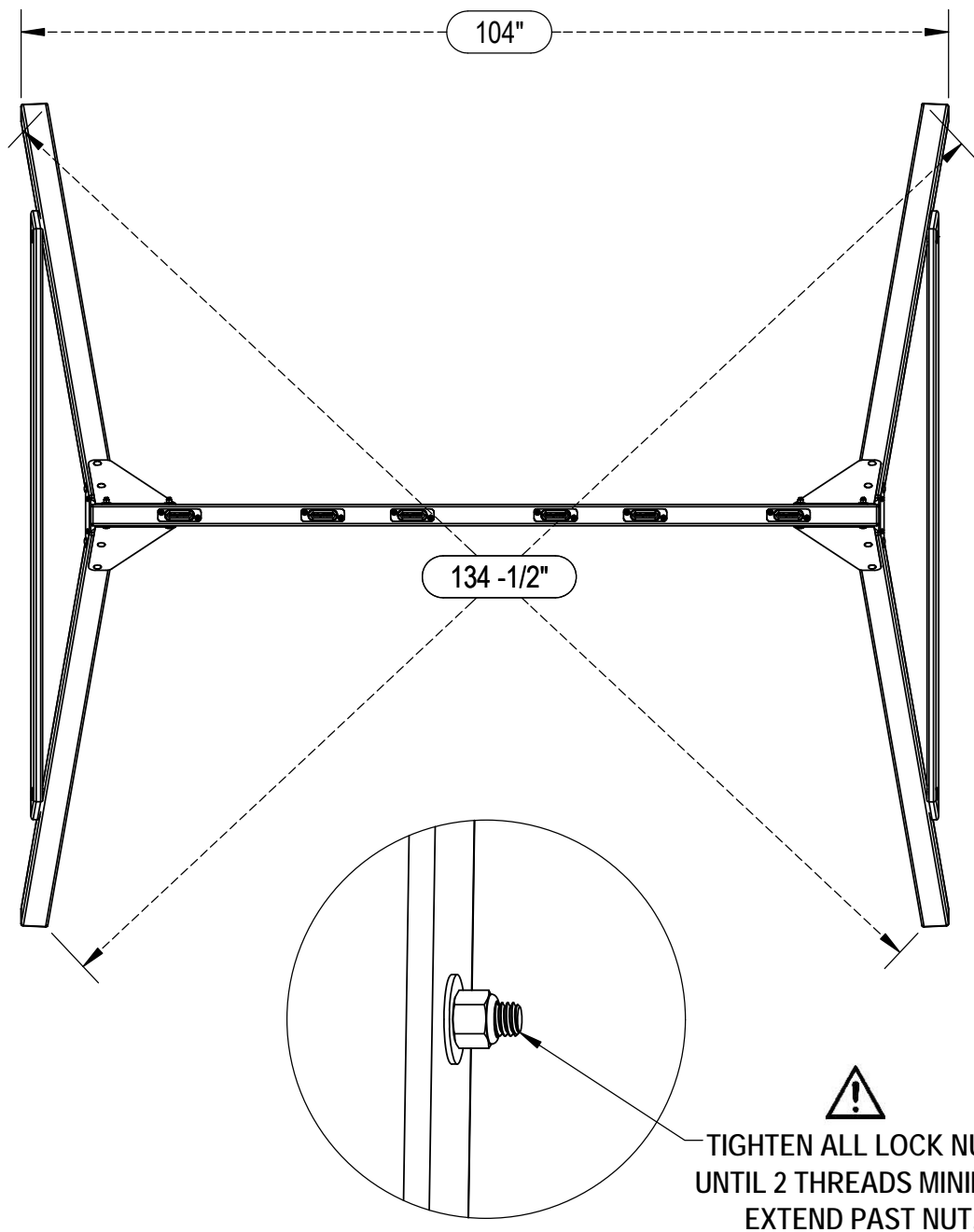

1. MOVE PLAYSET INTO ITS FINAL POSITION. MAKE SURE PLAYSET IS SQUARE.
2. FULLY TIGHTEN ALL FASTENERS AT THIS TIME. ENSURE TWO THREADS MINIMUM PROTRUDE PAST LOCK NUTS.

STEP 9: SECURING L-BRACKETS

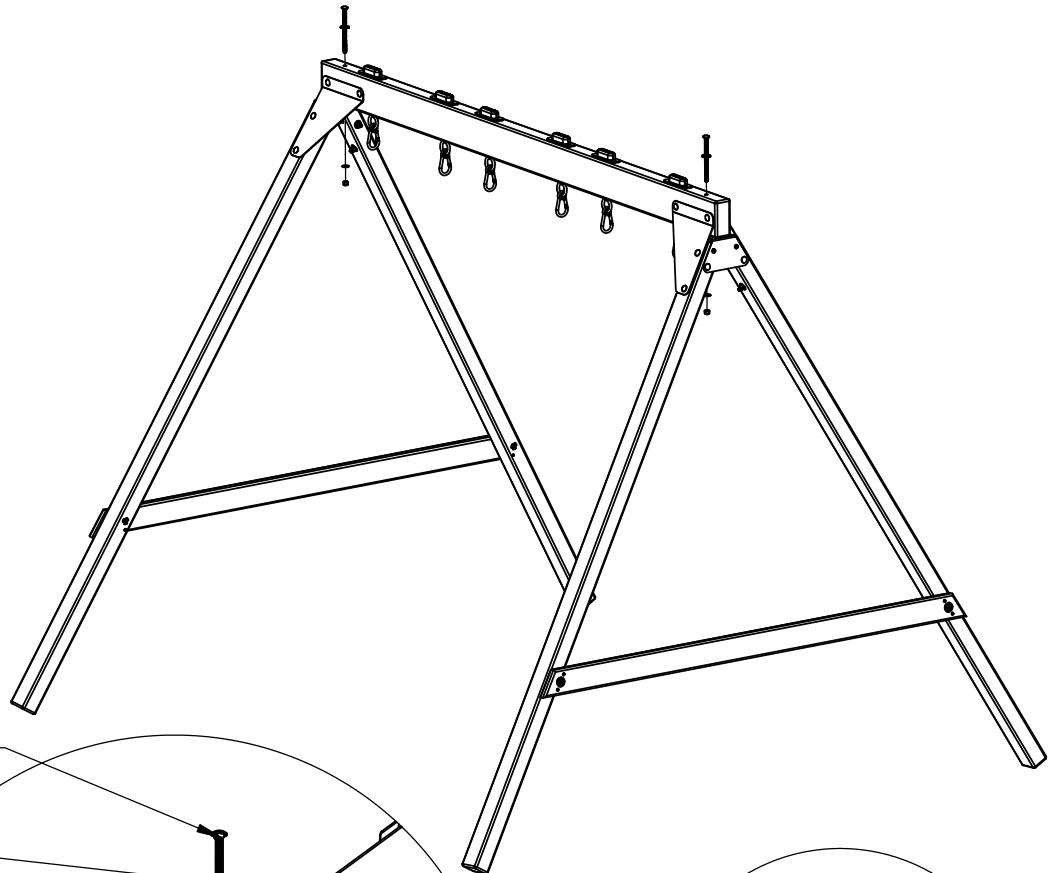

3/8" X 6" CARRIAGE BOLT X 2

TORQUE WASHER X 2

3/8" FLAT WASHER X 2

3/8" LOCK NUT X 2

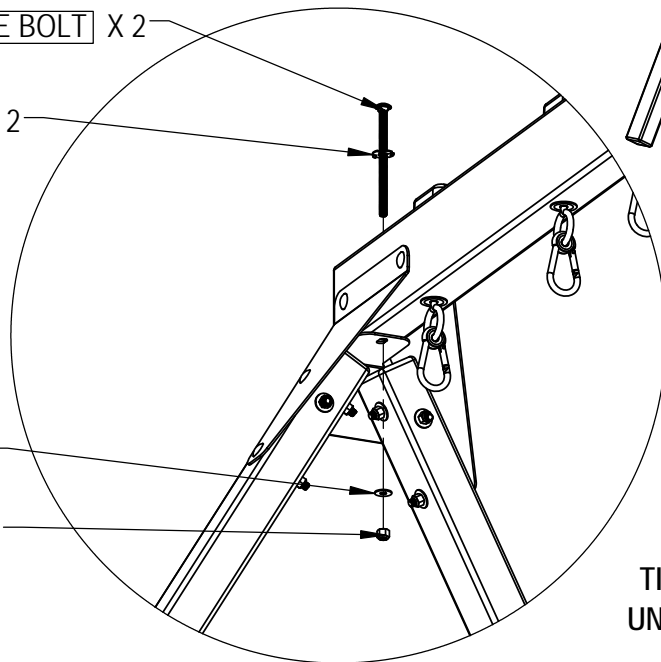



TIGHTEN ALL LOCK NUTS
UNTIL 2 THREADS MINIMUM
EXTEND PAST NUT.

1. RUN CARRIAGE BOLT THROUGH TORQUE WASHER AND USE A HAMMER TO SEAT THE TORQUE WASHER INTO SWING BEAM.
2. IF MORE THAN TWO THREADS ARE EXPOSED PAST LOCK NUT, ADD ONE OR TWO FLAT WASHERS UNTIL TWO THREADS ARE EXPOSED.

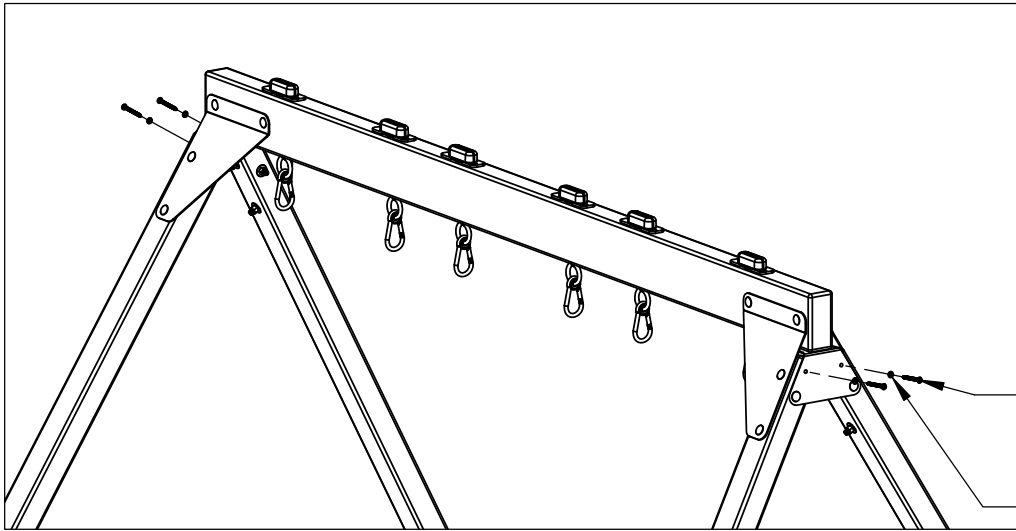
STEP 10: SECURING PLAYSET



-   PRE-DRILL ϕ 1/8" X 2" DEEP.
- 1/4" X 2-1/2" PAN HEAD SCREWS
X 4
- 1/4" LOCK WASHER X 4

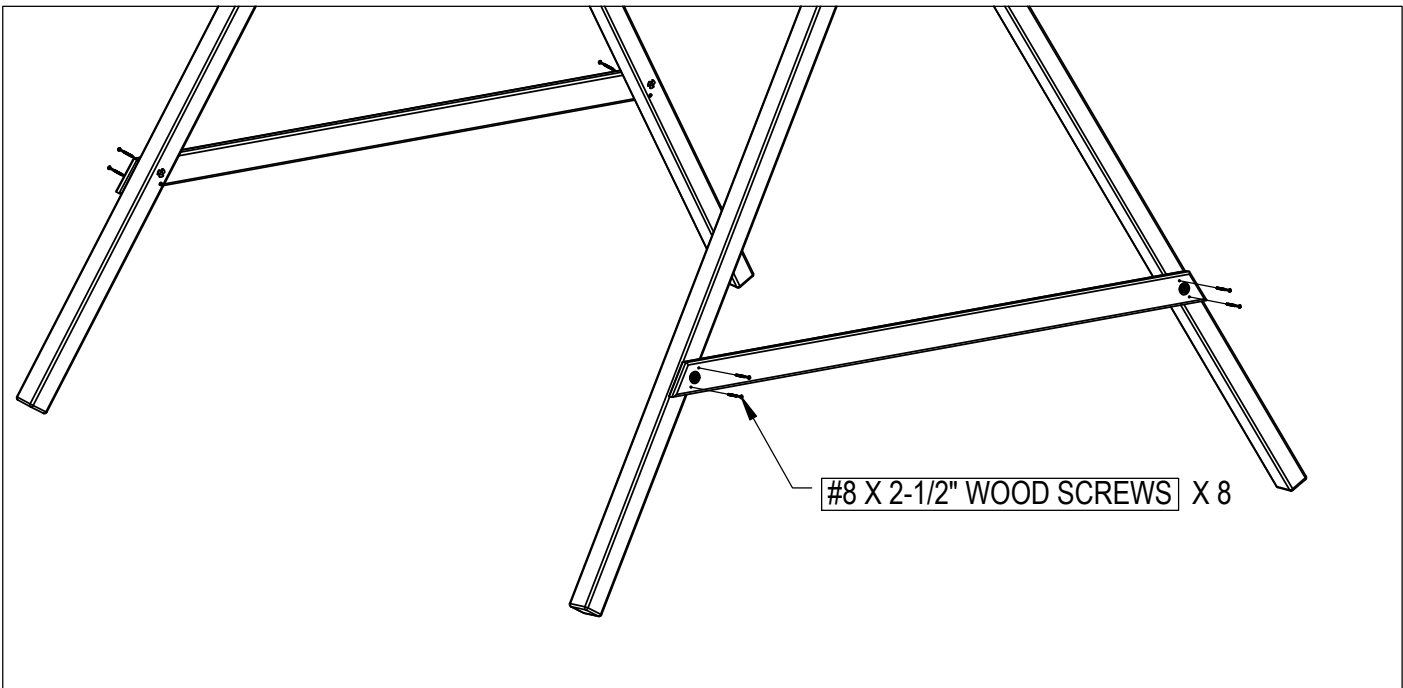

#8 X 2-1/2" WOOD SCREWS X 8

1. SECURE PLAYSET WITH WOOD SCREWS AS SHOWN.

STEP 11: TRAPEZE ASSEMBLY

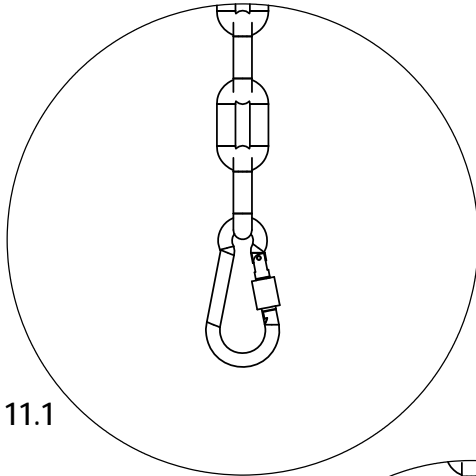

FIG. 11.1

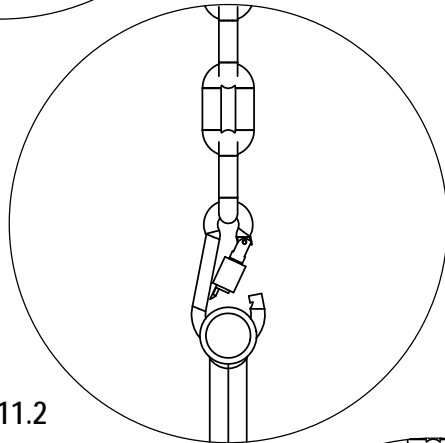

FIG. 11.2

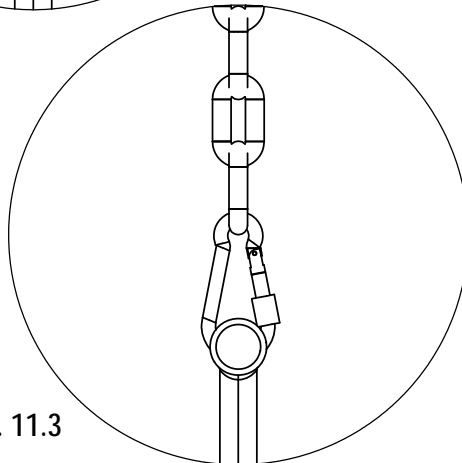
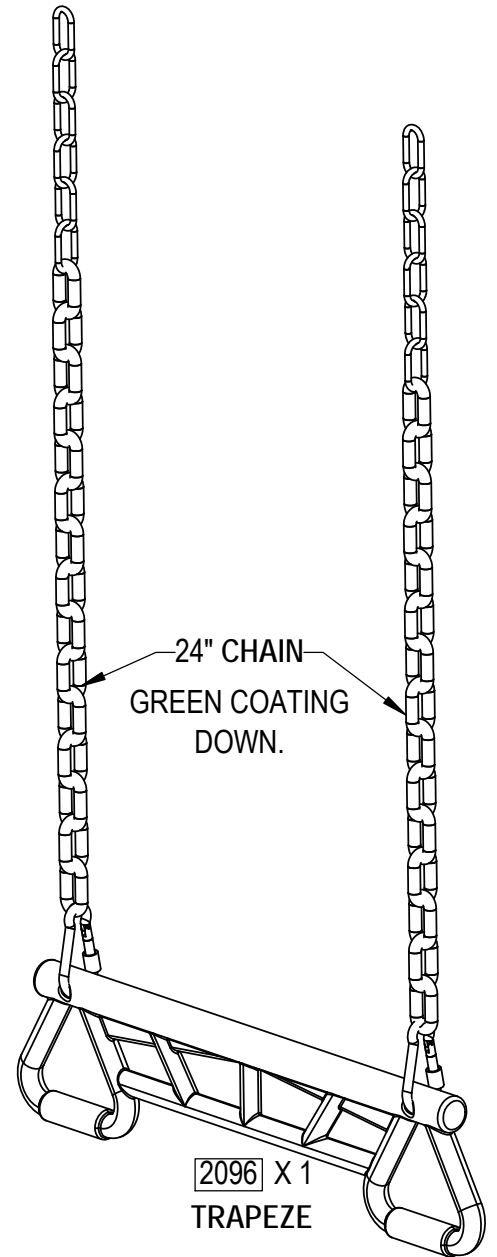
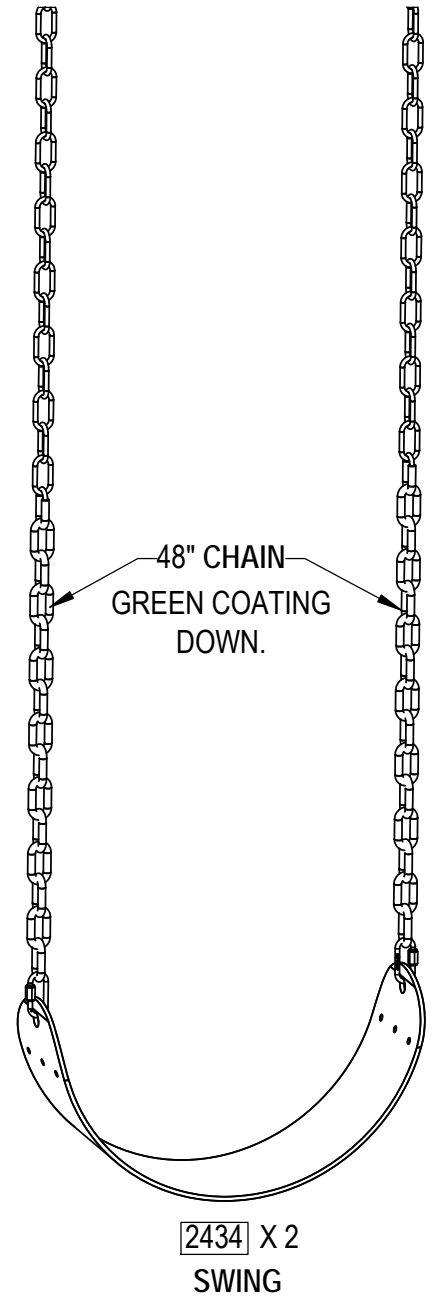
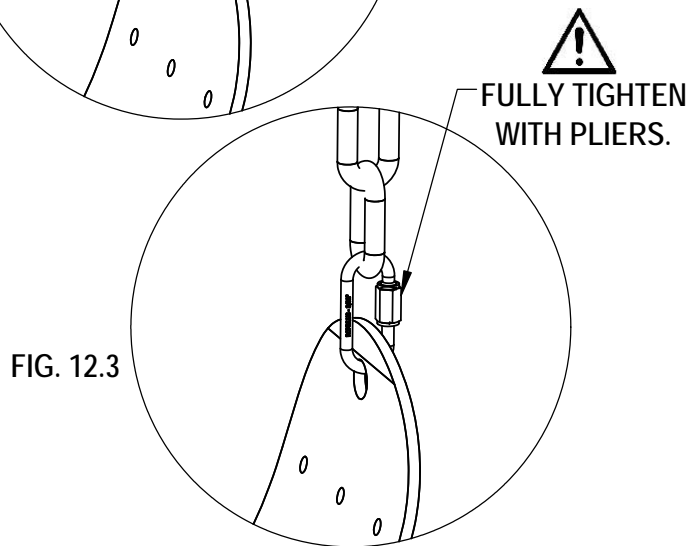
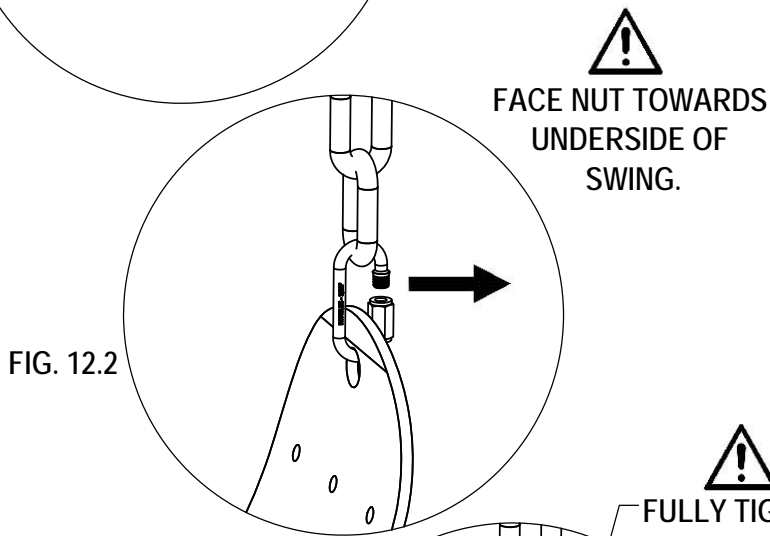
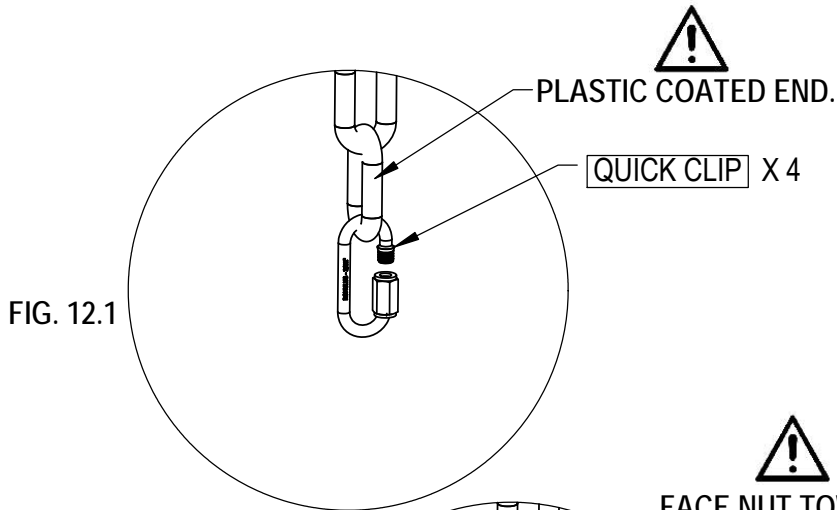

FIG. 11.3



1. ATTACH CHAIN TO SPRING CLIP FIRST, POSITION AT TOP OF CLIP. (FIG 11.1)
2. ATTACH SPRING CLIP TO TRAPEZE. (FIG. 11.2)
3. CLOSE AND TIGHTEN SPRING CLIP. LOCK WITH PLIERS. (FIG. 11.3)

STEP 12: SWING ASSEMBLY



1. ATTACH CHAIN TO QUICK CLIP FIRST, POSITION AT TOP OF LINK AS SHOWN. (FIG. 12.1)
2. PLACE THE QUICK CLIP THROUGH THE GROMMET OF THE SWING. (FIG 12.2)
3. FULLY TIGHTEN THE THREADED SLEEVE OF THE QUICK CLIP WITH PLIERS. (FIG. 12.3)
4. REPEAT FOR SECOND CHAIN, QUICK CLIP AND SWING.

STEP 13: HANGING SWING

FIG. 13.1



INSERT CHAIN DIRECTLY INTO SWING HANGER.

UNCOATED END OF CHAIN.

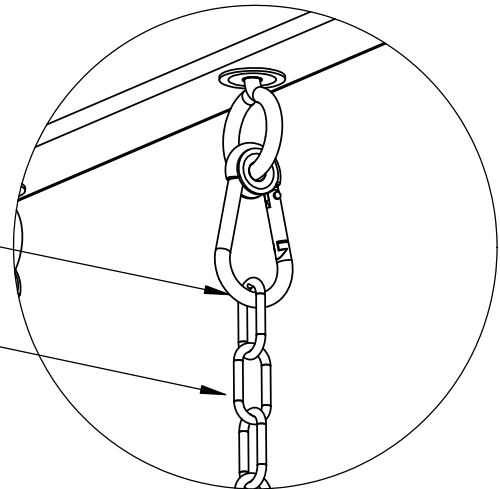
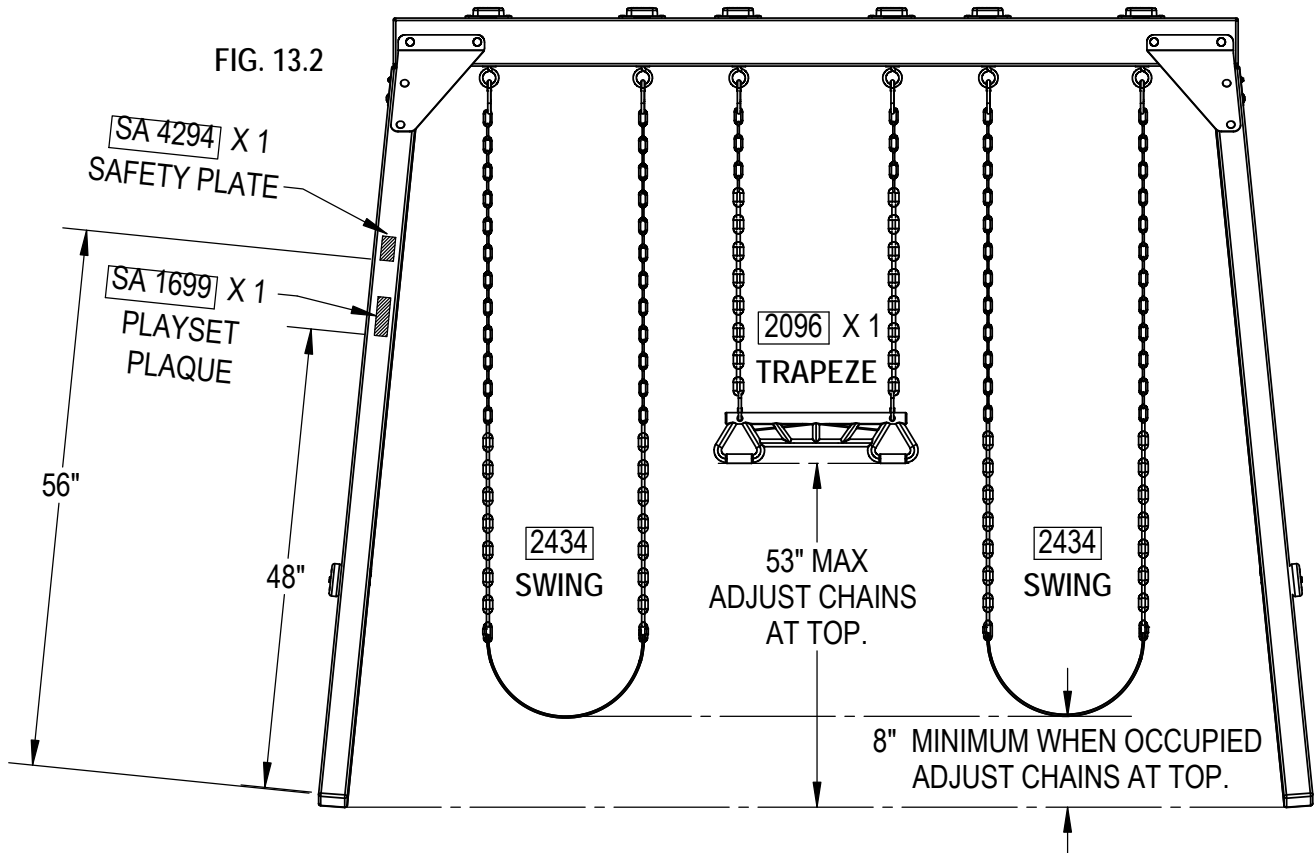

FIG. 13.2



1. ATTACH THE SWINGS AND TRAPEZE CHAINS TO THE SPRING CLIPS ON THE SWING HANGERS AS SHOWN. (FIG. 13.1)
2. ATTACH PLAYSET PLAQUE AND SAFETY PLATE TO SET AS INDICATED WITH SCREWS PROVIDED AS SHOWN. (FIG 13.2)



IMPORTANT!

MAX WEIGHT FOR EACH SWING ELEMENT IS 115 lbs.

STEP 14: ANCHOR-IT

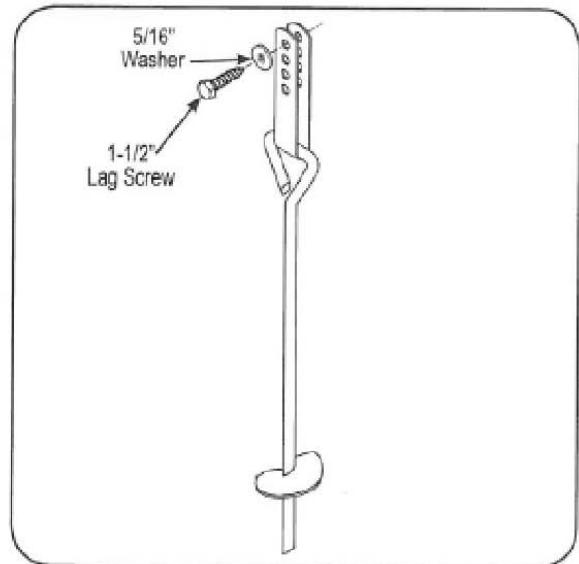
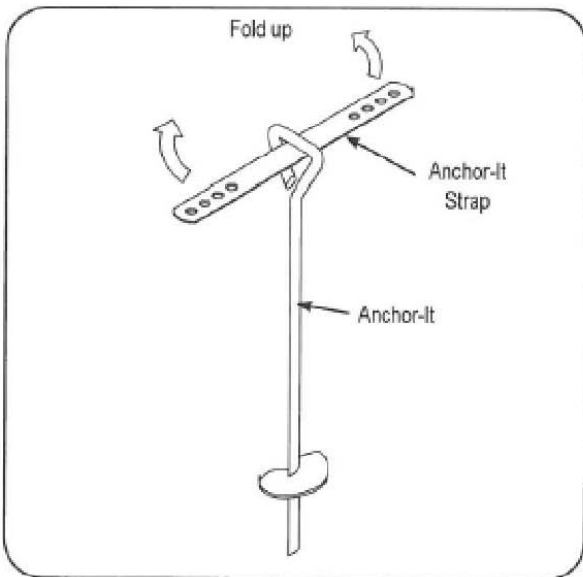
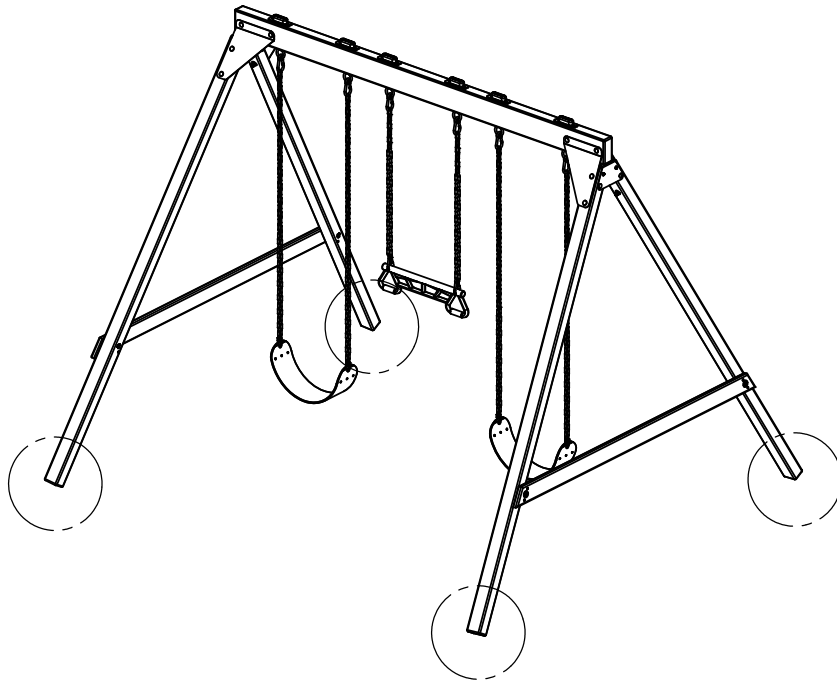

1. AT LOCATIONS CIRCLED ABOVE, TWIST THE ANCHOR-IT INTO THE GROUND UNTIL ONLY THE LOOP IS EXPOSED.
2. PLACE ANCHOR-IT STRAP THROUGH, FOLD THE ENDS TOGETHER AND ATTACH TO THE UNIT AS SHOWN.

NOTE: KEEP AS LITTLE PLAY AS POSSIBLE USING ANY OF THE HOLES IN THE STRAP THAT WORK BEST.

TIP: WHEN INSTALLING ANCHOR-IT IN ROCKY OR HARD SOIL, CREATE A STARTER HOLE AT THE DESIRED LOCATIONS USING EITHER A 16" CONCRETE DRILL BIT, OR A LONG SCREW DRIVER THEN INSERT AND INSTALL THE ANCHOR-IT AS SHOWN. THIS WILL ALLOW YOU TO GET TRACTION WITH THE ANCHOR-IT FASTER AND ALLOW THE DEVICE TO SEAT MORE SECURELY.

Swing-N-Slide® MANUFACTURERS LIMITED WARRANTY

IMPORTANT

Keep your proof of purchase and receipt.

Swing-N-Slide® takes great pride in the quality and durability of our products. Our Manufacturer's Limited Warranty provides confidence and demonstrates our commitment to providing quality residential playground products.

MANUFACTURER'S LIFETIME LIMITED WARRANTY

Swing-N-Slide® warrants its thermoformed slides and climbing mountains to be free from defects in workmanship and materials, under normal use and conditions, for the lifetime of the product.

MANUFACTURER'S 5 YEAR LIMITED WARRANTY

Swing-N-Slide® warrants its Custom Ready-to-Build Play Set kits and accessories to be free from defects in workmanship and materials, under normal use and conditions, or a period of 5 years.

MANUFACTURER'S 5 YEAR LIMITED WARRANTY

Swing-N-Slide® warrants its No-Cut and Wood Complete Ready-to-Assemble Play Set kits against wood rot and termite damage, and to be free from defects in workmanship and materials, under normal use and conditions, for a period of 5 years for structural wood components.

Cosmetic defects that do not affect the structural integrity of the product, or natural defects of wood such as warping, splitting, checking, twisting, shrinkage, swelling or any other physical properties of wood that do not present a safety hazard, are not covered by this warranty.

MANUFACTURER'S ACCESSORY, PLAYHOUSE WARRANTY

Swing-N-Slide® warrants its playset accessories and accessories sold separately as follows: Rope, Canopy/Tarps, Playhouses – 1 year. Plastic Components, Chains, Hardware and Fasteners – 5 years. These items to be free from defects in workmanship and materials, under normal use and conditions, for the period specified.

Swing-N-Slide® will repair, or at its discretion, replace any part within the stated warranty period which is defective in workmanship or materials. This decision is subject to verification of the defect upon delivery of the defective part to Swing-N-Slide® 166 Etowah Industrial Court Canton, GA 30114 Any part(s) returned to Swing-N-Slide® must have prior approved Return Authorization Number and proof of purchase, including the date of purchase. This warranty is valid only if the product is used for the purpose for which it was designed and installed at a residential, single family dwelling. This warranty is void if the product is put to commercial or institutional use. This warranty does not cover (a) products which have been damaged by acts of Nature, negligence, misuse, or accident, or which have been modified or repaired by unauthorized persons; (b) the cost of labor; or the cost of shipping the product, any part, or any replacement product or part.

Swing-N-Slide® DISCLAIMS ALL OTHER REPRESENTATIONS AND WARRANTIES OF ANY KIND, EXPRESS, IMPLIED, STATUTORY OR OTHERWISE, INCLUDING THE IMPLIED WARRANTIES OF MERCHANTABILITY AND FITNESS FOR A PARTICULAR PURPOSE. Swing-N-Slide® WILL NOT BE LIABLE FOR ANY INCIDENTAL OR CONSEQUENTIAL DAMAGES. This warranty is non-transferable and does not extend to the owners of the product subsequent to the original purchaser. Some states do not allow limitations on implied warranties or exclusion of incidental or consequential damages, so these restrictions may not be applicable to you. This warranty gives you specific legal rights. You may also have other rights, which vary from state to state.

This warranty also does not apply to:

- Structures not erected, maintained or inspected in conformance with **Swing-N-Slide®** installation plans
- Structures that have had parts added or substituted not in conformance with **Swing-N-Slide®** installation plans
- Parts that have been modified, altered or misused
- Parts that have not been used as designed or intended
- Damage due to acts of Nature, vandalism, abnormal use or abuse as determined by **Swing-N-Slide®**



Got Questions? We've got answers!
Call our Customer Support Representatives

1-800-882-0272

Available Monday - Friday, 8am - 5pm (EST)

Technical support from experienced Swing-N-Slide customer service representatives who have actually built a swing set themselves.