

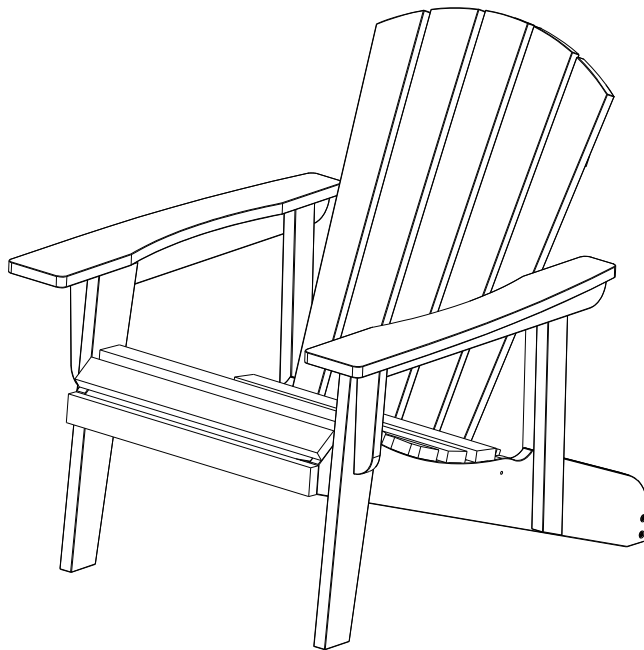

OWNER'S MANUAL



TRINITY ECOSTORAGE® RECLINING ADIRONDACK CHAIR
ESPRESSO BROWN / SLATE GRAY
Model # THBBR-3103 / THBGR-3103



Important / Important / Importante

FOR QUICK & EASY 3D ASSEMBLY INSTRUCTIONS

POUR DES DIRECTIVES D'ASSEMBLAGE 3D RAPIDES ET FACILES

PARA INSTRUCCIONES DE ENSAMBLAJE RÁPIDAS Y SENCILLAS EN 3D

BILT.[®]

Intelligent Instructions
Directives intelligentes
Instrucciones Inteligentes



DOWNLOAD THE FREE APP | TÉLÉCHARGER L'APPLICATION GRATUITE | DESCARGUE LA APLICACIÓN GRATUITA

PARTS LIST

Your TRINITY EcoStorage® Adirondack Reclining Chair should include the following parts. Please inspect box contents to ensure you have received all components.

If you are missing any parts, need assistance with assembly or have questions, please contact TRINITY Customer Service: 800.985.5506 or customerservice@trinityii.com. Parts can also be requested online via "Contact Us" section at www.trinityii.com.

You will NOT need additional tools for assembly.

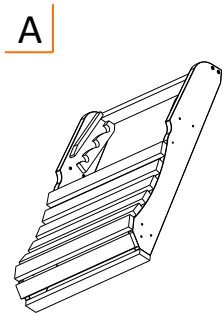

SEAT (1)

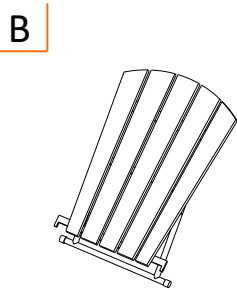

BACKREST (1)

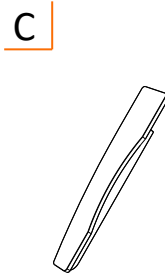

LEFT ARMREST (1)

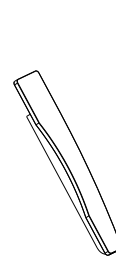

RIGHT ARMREST (1)

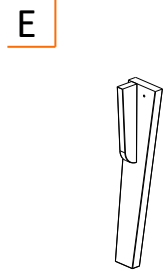

LEFT FRONT LEG (1)

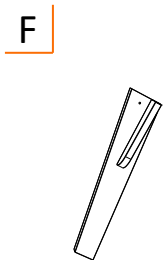

RIGHT FRONT LEG (1)

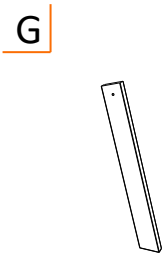

LEFT SUPPORT (1)

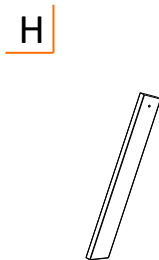

RIGHT SUPPORT (1)



NUT (2)



WASHER (2)

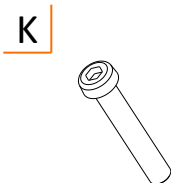

SCREW (16)
M6 X 35



HEX KEY (1)



WRENCH (1)

ASSEMBLY INSTRUCTIONS

STEP 1

NOTE: Make sure you have parts labeled (C), (E) and (G) for this step. They look very similar to parts (D), (F), and (H).

Lay SEAT (A) on ground sideways as shown, orient (3) insert nuts on LEFT FRONT LEG (E) to align with (3) holes on SEAT (A). Insert (3) SCREWS (K), from inside, through SEAT (A) and hand fasten to LEFT FRONT LEG (E). Then with HEX KEY (L) tighten (3) SCREWS (K).

Orient (2) insert nuts on LEFT SUPPORT (G) to align with (2) holes on SEAT (A). Insert (2) SCREWS (K), from inside, through SEAT (A) and hand fasten to LEFT SUPPORT (G). Then with HEX KEY (L) tighten (2) SCREWS (K).

Put LEFT ARMREST (C) on LEFT FRONT LEG (E) and LEFT SUPPORT (G), making sure holes are aligned with insert nuts. Insert SCREW (K) through LEFT ARMREST (C) and hand fasten to LEFT FRONT LEG (G). Insert SCREW (K) through LEFT ARMREST (C) and hand fasten to LEFT SUPPORT (G). Finally tighten both SCREWS (K) with HEX KEY (L).

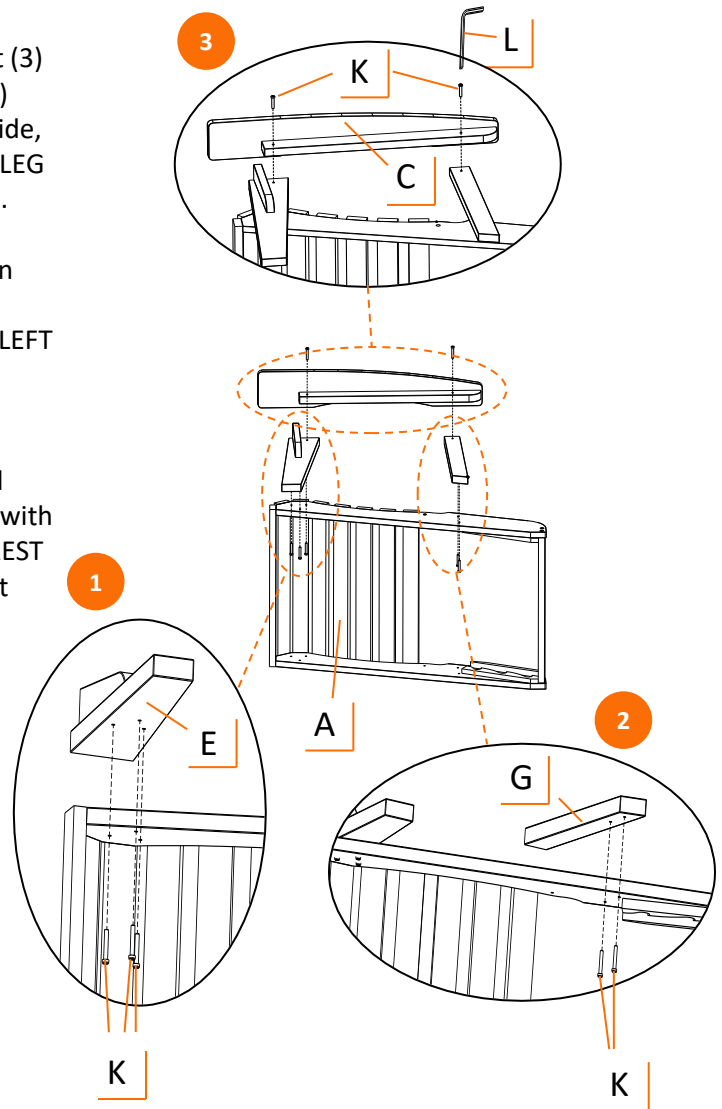
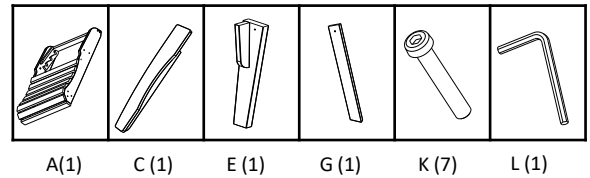

Completed STEP 1 assembly

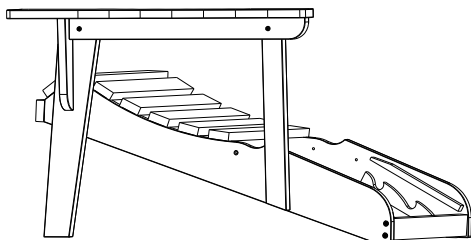

ASSEMBLY INSTRUCTIONS

STEP 2

Flip over completed assembly from STEP 1 and lay on ground as shown.

Orient (2) insert nuts on RIGHT SUPPORT (H) to align with (2) holes on SEAT (A). Insert (2) SCREWS (K), from inside, through SEAT (A) and hand fasten to RIGHT SUPPORT (H). Then with HEX KEY (L) tighten (2) SCREWS (K).

Orient (3) insert nuts on RIGHT FRONT LEG (F) to align with (3) holes on SEAT (A). Insert (3) SCREWS (K), from inside, through SEAT (A) and hand fasten to RIGHT FRONT LEG (F). Then with HEX KEY (L) tighten (3) SCREWS (K).

Put RIGHT ARMREST (D) on RIGHT FRONT LEG (F) and RIGHT SUPPORT (H), making sure holes are aligned with insert nuts. Insert SCREW (K) through RIGHT ARMREST (D) and hand fasten to RIGHT SUPPORT (H). Insert SCREW (K) through RIGHT ARMREST (D) and hand fasten to RIGHT FRONT LEG (F). Finally tighten both SCREWS (K) with HEX KEY (L).

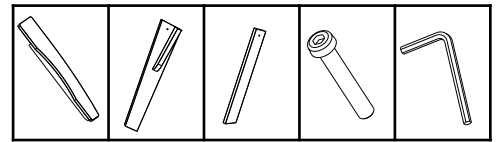

D(1) F(1) H(1) K(7) L(1)

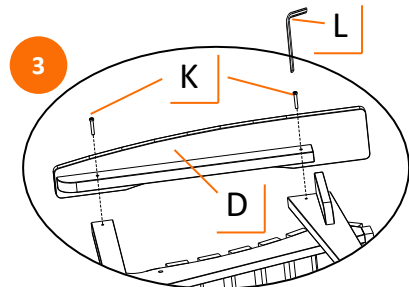

3

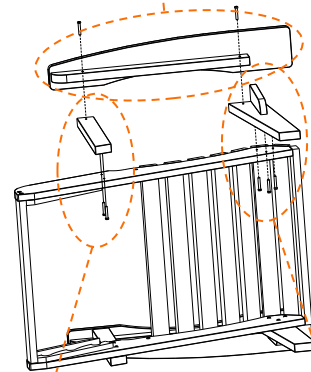

1

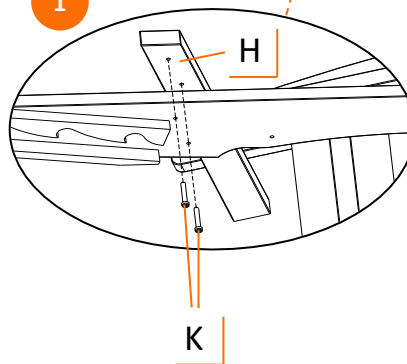

K

2

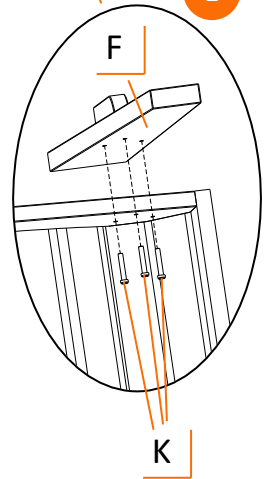

K

Seat Assembly after STEP 2

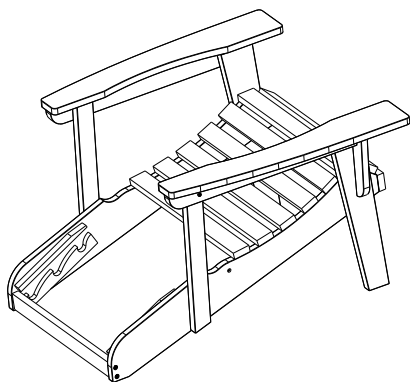

ASSEMBLY INSTRUCTIONS

STEP 3

With 2 people, carefully hold BACKREST (B) over Seat Assembly. Slide Back Support into notches on each side of SEAT (A).

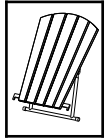

B (1)

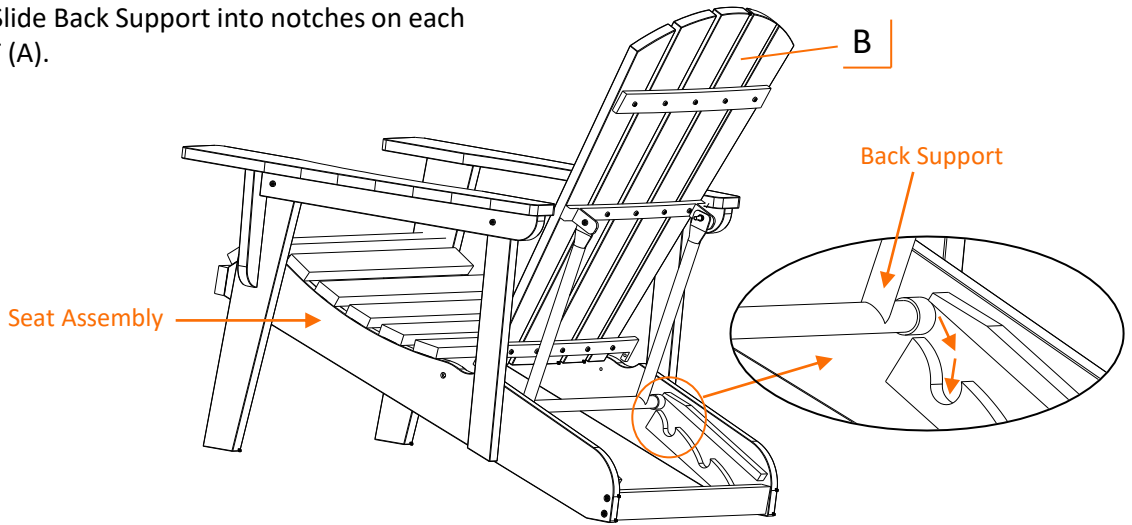

STEP 4

On left side, insert SCREW (K) through SEAT (A), BACKREST (B) and WASHER (J). With WRENCH (M) holding NUT (I) in place, tighten SCREW (K) onto NUT (I) with HEX KEY (L).

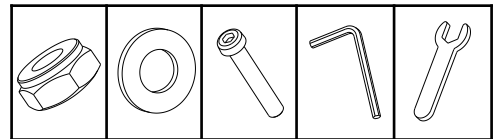

I (2)

J (2)

K (2)

L (1)

M (1)

Repeat for right side.

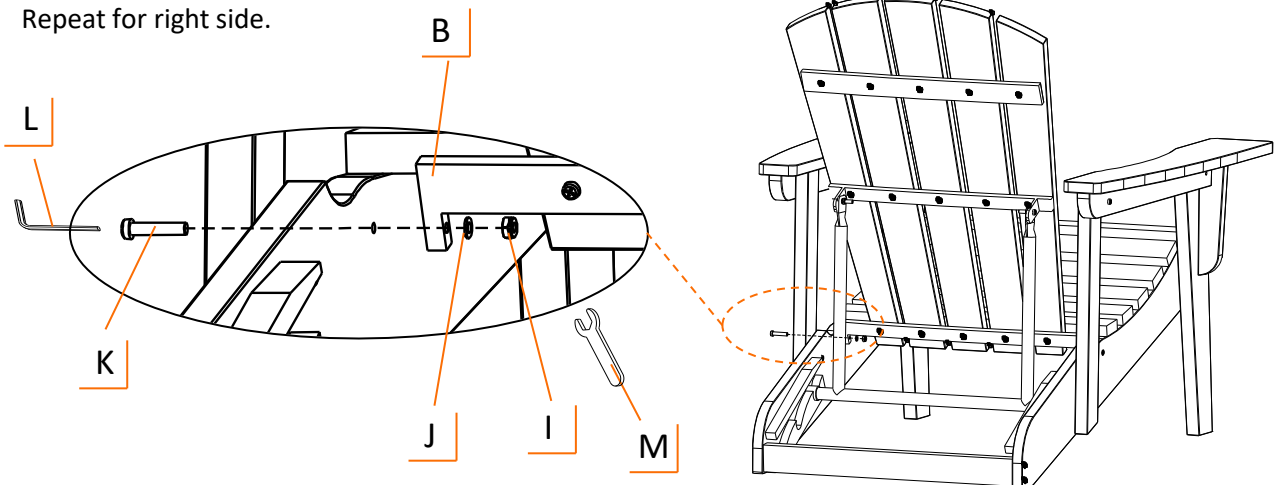

USAGE INSTRUCTIONS

ADJUST SEAT BACK RECLINE POSITIONS

There are 3 reclining positions. Lift BACKREST (B) and move Back Support to position you desire.

POSITION 1

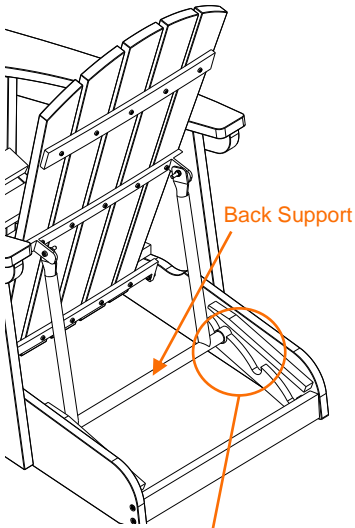

POSITION 2

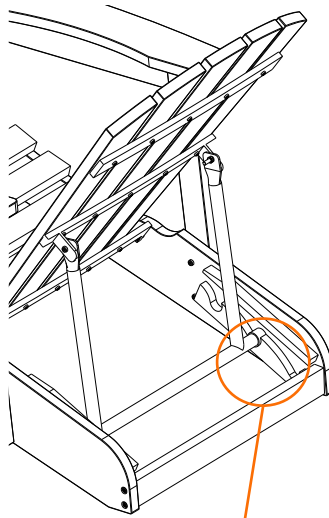

POSITION 3

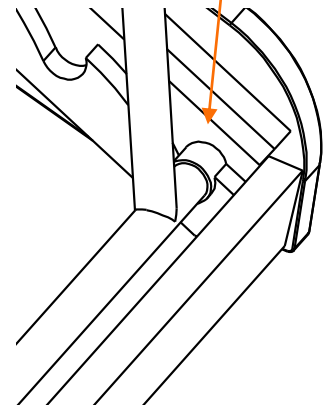
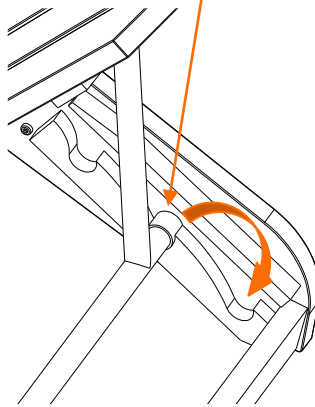
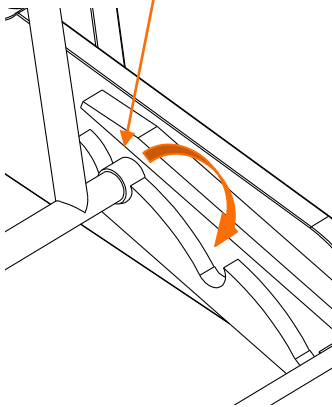
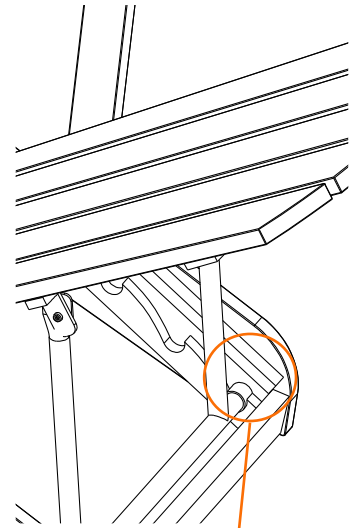

SERVICE PARTS LIST- THBBR-3103 ESPRESSO BROWN

TRINITY Customer Service provides the following replacement parts:

Part Number	Description	Part Number	Description
1) PBK-25-005-0002	Back Support	10) XXX-97-002-0006	Wrench
2) XBK-23-004-2540	End Cap	11) XXX-97-001-0001	Hex Key
3) XBR-25-005-0001	Backrest	12) XBR-25-004-0005	Right Front Leg
4) XBK-01-026-0635	Screw	13) XBR-25-004-0004	Right Armrest
5) XBR-25-004-0003	Left Support	14) XSV-01-018-0606	Nut
6) XBR-25-004-0001	Left Armrest	15) XSV-01-019-0612	Washer
7) XBR-25-004-0002	Left Front Leg	16) XBK-01-026-0620	Back Support Screw
8) XBR-25-003-0001	Seat	17) XBK-01-041-0615	Plastic Washer
9) XBR-25-004-0006	Right Support		

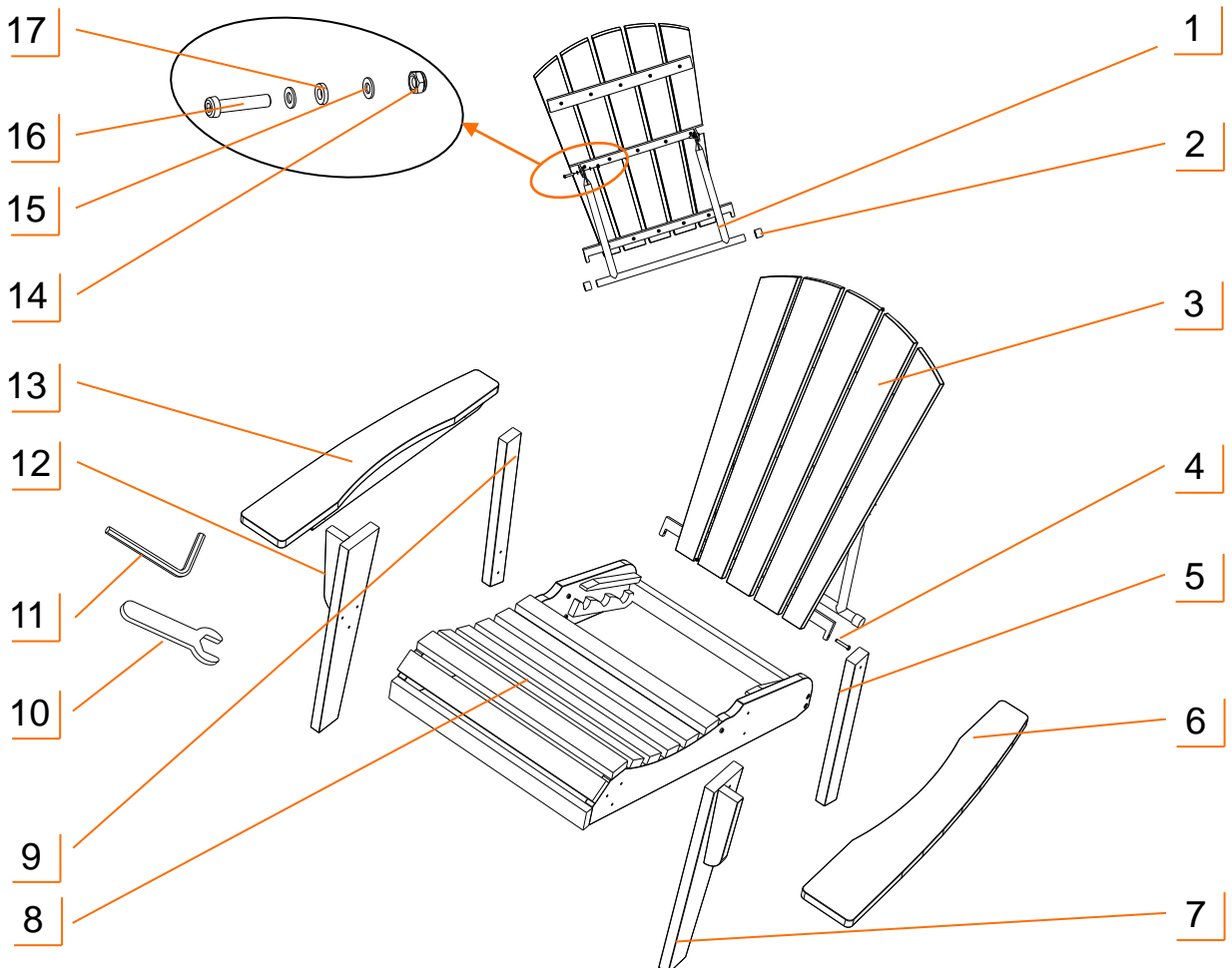

SERVICE PARTS LIST- THBGR-3103 SLATE GRAY

TRINITY Customer Service provides the following replacement parts:

Part Number	Description	Part Number	Description
1) PBK-25-005-0002	Back Support	10) XXX-97-002-0006	Wrench
2) XBK-23-004-2540	End Cap	11) XXX-97-001-0001	Hex Key
3) XGR-25-005-0001	Backrest	12) XGR-25-004-0005	Right Front Leg
4) XBK-01-026-0635	Screw	13) XGR-25-004-0004	Right Armrest
5) XGR-25-004-0003	Left Support	14) XSV-01-018-0606	Nut
6) XGR-25-004-0001	Left Armrest	15) XSV-01-019-0612	Washer
7) XGR-25-004-0002	Left Front Leg	16) XBK-01-026-0620	Back Support Screw
8) XGR-25-003-0001	Seat	17) XBK-01-041-0615	Plastic Washer
9) XGR-25-004-0006	Right Support		

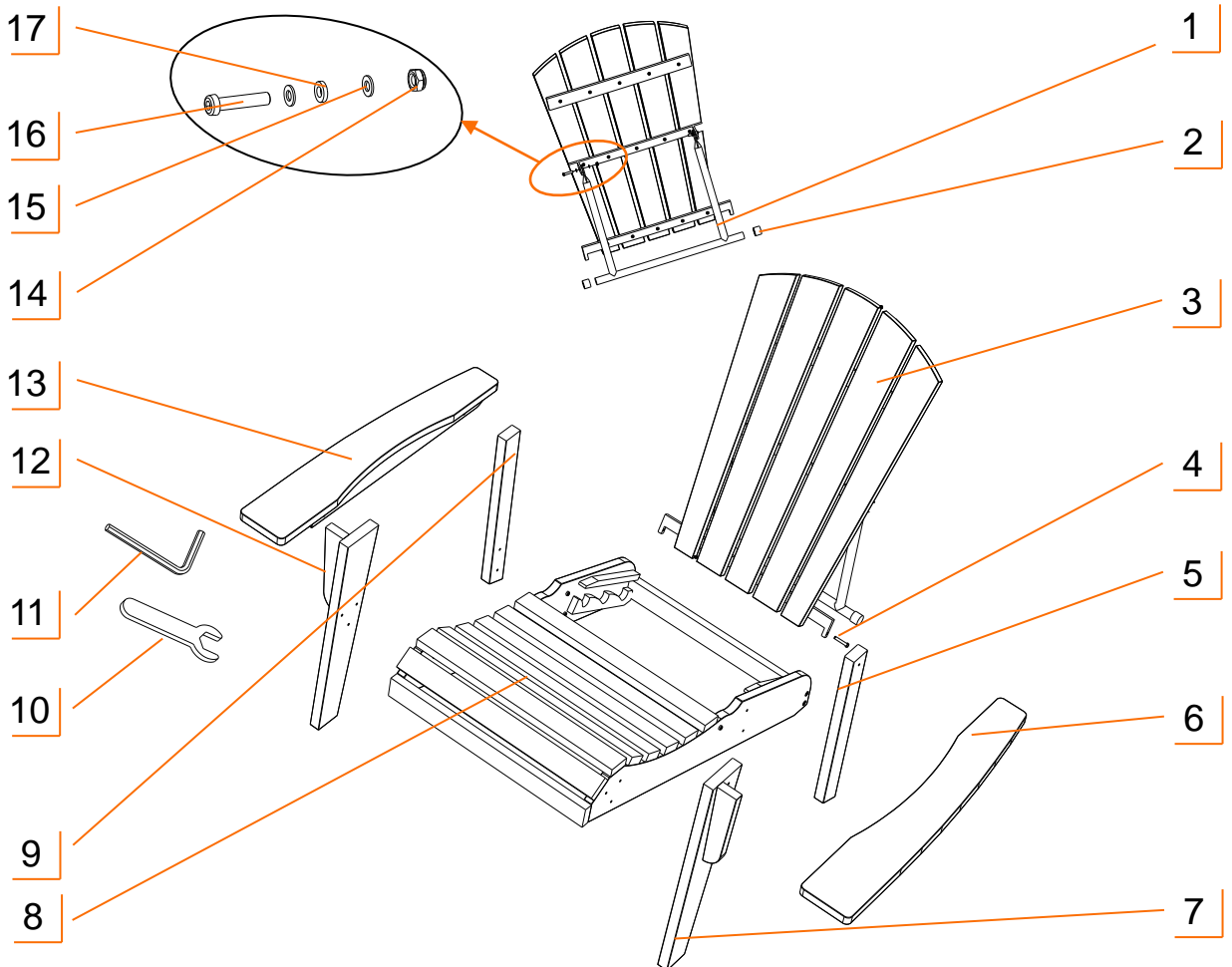

WARNINGS

1. **Read and understand all instructions.** Failure to follow all instructions may result in injury and/or damage.
2. **The warnings, cautions, and instructions discussed in this manual cannot cover all possible conditions or situations that may occur.** The user must always be aware of their environment and ensure that they use the product in a safe and responsible manner.
3. **Do NOT modify the product in any way.** Unauthorized modification may impair the function and/or safety of the product, and may affect the life of the product. Any modifications will void warranty.
4. **Check for damaged parts.** Before using this product, carefully check that all parts are in good condition, and that the product will operate properly and perform its intended function. Check for damaged parts and any other conditions that may affect the operation of this product. Replace damaged or worn parts, and never use this product with a damaged part.
5. **Do NOT overload the product.**

Total weight capacity	300 lb (evenly distributed)
-----------------------	-----------------------------
6. **Do NOT sit on the armrest or backrest.** Tipping may occur causing injury.
7. **Do NOT allow children to play with backrest reclining mechanism.**
8. **Do NOT allow children to climb onto or hang from backrest.** Tipping may occur causing injury.
9. **The backrest must be locked in a position slot before sitting in the chair.**
10. **Do NOT adjust the backrest while someone is sitting in the chair.**
11. **This is made with UV-stabilizers to minimize fading, however, upon exposure to the sun, all colors will fade to some degree.** To minimize possible fading: keep product covered, utilize cushions where applicable, minimize direct sunlight by storing product when not in use, or use a UV-protectant.

CARE AND MAINTENANCE

- Avoid harsh, abrasive cleaners, and other corrosive chemicals.
- Do not use metal scouring pad for cleaning. Most stains can be removed by using a mild soap and a soft-bristled brush.
- Avoid placing any direct heat source on or near the surface.
- Leaving any glassware on Chair under sunlight may result in burn marks on the surface. Please use a coaster when placing glassware on Chair .

PRODUCT REGISTRATION

Thank you for purchasing a TRINITY EcoStorage® Reclining Adirondack Chair . In order to register your product and receive streamlined customer service, please fill out the following Product Registration Form and (1) fax the form to 310.347.4134 (2) complete the Product Registration Form online at www.trinityii.com or (3) scan and email the form to customerservice@trinityii.com. Include a copy of your original receipt with your submission.

First Name: _____ Last Name: _____

Address: _____

City: _____ State: _____ Zip Code: _____

Email Address: _____ Phone: _____

Product Model #: THBBR-3103/THBGR-3103 Purchase Date: ____ / ____ / ____

Location of Purchase: _____

Please rate the importance of each feature (1=least important; 10=most important)

Quality ____ Price ____ Size/Capacity ____ Appearance ____ Other ____

How did you hear about our product?

- Magazine Ad Catalog Salesperson Word of Mouth
 Internet Store Display Other

Marital Status: Single Married

Household Income: Below \$50,000 \$50,000-\$150,000 \$150,000+

Education: High School College Graduate School

Primary Residence: Own Rent

Comments/Suggestions:



1 YEAR LIMITED WARRANTY

TRINITY EcoStorage® Reclining Adirondack Chair Model # THBBR-3103 / THBGR-3103

Trinity International Industries (“Trinity”) warrants to the original consumer purchaser (“Purchaser”) of the TRINITY EcoStorage® Reclining Adirondack Chair (“Product”) that each Product shall be free from defects in workmanship and materials for a period of 1 year from the date of original purchase. Trinity’s obligation under this warranty shall be limited to repair or replacement of, or adequate compensation for the Product which shall not be greater than the amount of the purchase price of the Product, at the option of Trinity, during the warranty period. All replaced parts and Products become the property of Trinity and must be returned to Trinity.

This warranty excludes normal wear and tear of the Product and its parts or components, and damage arising from any of the following: negligent use or misuse of the Product, use contrary to this User’s Manual, or alteration by any one other than Trinity. The warranty period of 1 year shall not be extended or renewed by the repair or replacement of, or compensation for, the Product. Any warranty implied by applicable law is limited in duration to one year from the date of purchase and is subject to the same conditions and limitations as is provided for our express warranty.

Except as set forth herein, and to the extent of applicable there are no warranties on this Product either express or implied, and Trinity disclaims all warranties including, but not limited to, any implied warranties of merchantability, infringement or fitness for a particular purpose. No warranty or guarantee given by any person, firm, or corporation with respect to this product shall be binding on Trinity.

If your Product is defective or otherwise requires service or parts, please call TRINITY Customer Service toll-free at (800) 985-5506, between 5:00 a.m. and 5:00 p.m., PST. Please tell us which model you purchased, the date of the purchase, and the problem with your Product. A copy of your original purchase receipt must accompany your service request.

LIMITATION OF REMEDIES AND LIABILITY

Trinity (and its employees, officers, members, managers, affiliates and assigns) shall not be liable for any incidental, consequential, special, indirect, remote, special or punitive damages for breach of any warranty, express or implied, including, but not limited to, lost profits, lost savings, loss of anticipated benefits and attorneys’ fees, which arise out of the purchase, use or inability to use the Product, whether arising out of contract, negligence, strict tort, product liability, or any other legal theory on which a claim is based. As noted above, to the extent damages are allowed by our express warranty or by applicable law, those damages may not exceed the purchase price paid for the Product. Without limiting the foregoing Purchaser assumes all risk and liability for loss, damage or injury to Purchaser and Purchaser’s property and to others and their property arising out of the use, misuse, or inability to use this Product. This limited warranty shall not extend to anyone other than the original purchaser of this product, is nontransferable and states your exclusive remedy.

Some states do not allow the exclusion or limitation of incidental, consequential, special, or punitive damages, so the above limitation or exclusion may not apply to you. The above warranty gives you specific legal rights, and you may have other rights which vary from state to state.

CONTACT US

**QUESTIONS? NEED PARTS?
WE ARE HERE TO HELP!**

Please feel free to contact us. There are no questions too small, or any problems too big. We're committed to providing our customers with the highest level of service.

TRINITY Customer Service

TEL: 800.985.5506

FAX: 310.347.4134

EMAIL: customerservice@trinityii.com

**Monday through Friday
5:00 AM – 5:00 PM (PST)**

www.trinityii.com