

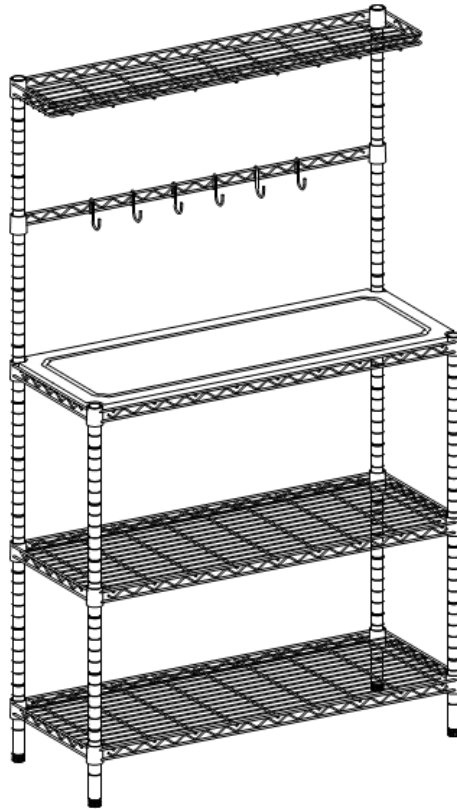

OWNER'S MANUAL



TRINITY EcoStorage® BAKER'S RACK

Model # TBFZ-1501



Important / Important / Importante

FOR QUICK & EASY 3D ASSEMBLY INSTRUCTIONS

POUR DES DIRECTIVES D'ASSEMBLAGE 3D RAPIDES ET FACILES

PARA INSTRUCCIONES DE ENSAMBLAJE RÁPIDAS Y SENCILLAS EN 3D

BILT.[®]

Intelligent Instructions
Directives intelligentes
Instrucciones Inteligentes



DOWNLOAD THE FREE APP | TÉLÉCHARGER L'APPLICATION GRATUITE | DESCARGUE LA APLICACIÓN GRATUITA

PARTS LIST

Your TRINITY EcoStorage® Baker's Rack should include the following parts. Please inspect box contents to ensure you have received all components.

If you are missing any parts, need assistance with assembly or have questions, please contact TRINITY Customer Service: 800.985.5506 or customerservice@trinityii.com. Parts can also be requested online via "Contact Us" section at www.trinityii.com.

You will NOT need additional tools for assembly.

A

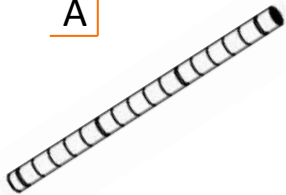

FRONT BOTTOM POLE (2)
End Cap (2), and Feet Leveler (2)
are pre-installed

B



BACK BOTTOM POLE (2)
Threaded Insert (2),
and Feet Leveler (2)
are pre-installed

C



TOP POLE (2)
End cap (2) and
Pole Connector (2)
are pre-installed

D

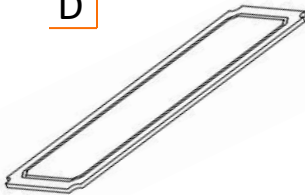

BAMBOO BOARD (1)

E

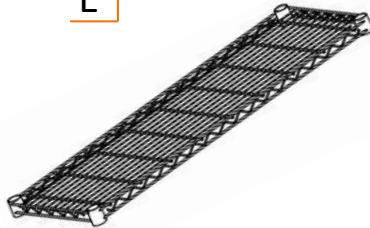

SHELF (3)

F



HANGING HOOK (6)

G



HANGING BAR (1)

H



CANTILEVER SHELF (1)

I



**SLIP SLEEVE
(32) + (2) extra**

PARTS LIST

Please inspect box contents to ensure you have received all components.



Note: The black circular plastic spacers in between Shelves are used only for packaging purposes. They are NOT needed. Please discard.

ASSEMBLY INSTRUCTIONS

STEP 1: SLIP SLEEVES

For easiest assembly, do not attach the TOP POLES (C) to the BACK BOTTOM POLES (B) until instructed. Once connected, these will be the posts for the Rack.

Note that each POLE (A+B+C) has slight horizontal line indentations at 1" intervals. Each SLIP SLEEVE (I) has raised horizontal lines inside designed to lock them in place on the POLE (A+B+C).

On POLE (A), place 1 pair of SLIP SLEEVES (I) at the desired level. Please make sure the arrow faces up and that the word "TOP" is right side up. Do this for each POLE (A & B), and make sure that the heights are identical for each POLE (A & B).

Slide the pair of SLIP SLEEVES (I) until you hear a click to confirm the pair is locked onto the POLE (A & B). DO NOT place more than one pair on each POLE (A & B) at a time.

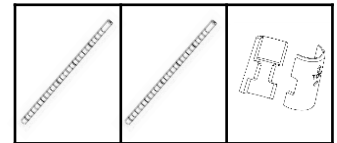

A (2)

B(2)

I (8)

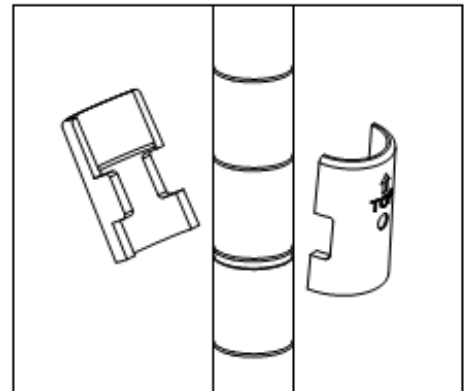

* For safety and stability, the lowest SHELF (E) should be lower than the 3rd notch from the bottom.

** Note: There will be a very small gap in-between the SLIP SLEEVES (I)—this is normal.

ASSEMBLY INSTRUCTIONS

STEP 2: INSTALLING SHELF

Slide the SHELF (E) over the top of the BOTTOM POLES (A & B) onto the SLIP SLEEVES (I). Make sure that the SHELF (E) corner cylinders are positioned over the SLIP SLEEVES (I). Check to make sure the TRINITY logo on the corner cylinders is right side up.



E (1)

Repeat this step for the second SHELF (E).

**Note: The level side of the SHELF is the TOP side (the TRINITY logo on the corner cylinders should be right-side up.)*

***Use a rubber mallet, if needed, to secure the SHELVES (E).*

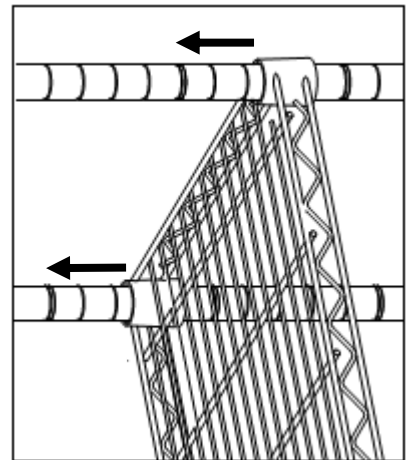

STEP 3: INSTALLING TOP POLES

After the first 2 SHELVES (E) are in place, screw the TOP POLE (C) into the BACK BOTTOM POLE (B).

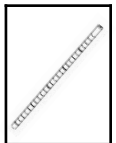

C (2)

The tops of the TOP POLE (C) are indicated by the BLACK END CAP.

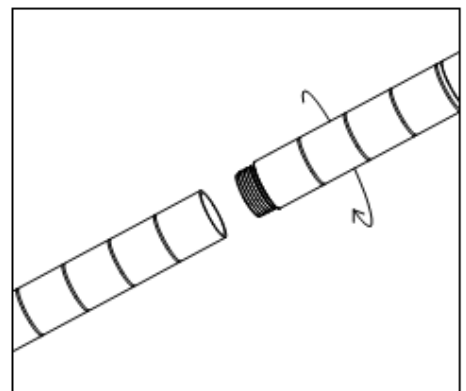

ASSEMBLY INSTRUCTIONS

STEP 4: INSTALLING SHELVES & HANGING BAR

Repeat Steps 2 and 3 for third SHELF (E), the HANGING BAR (G) and the CANTILEVER SHELF (H) and slide each piece over the SLIP SLEEVES (I).

Only install ONE item at a time.

Adjust to desired height

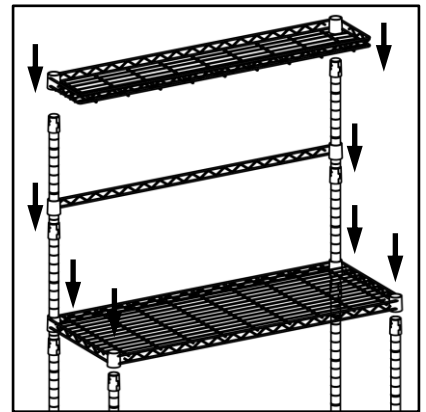
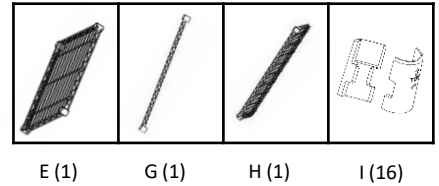

STEP 5: INSTALLING BAMBOO BOARD

Place the BAMBOO BOARD (D) on the third SHELF (E).
Remove the BAMBOO BOARD (D) to clean thoroughly.

Using mineral oil regularly will prevent your BAMBOO BOARD (D) from becoming dry and brittle.

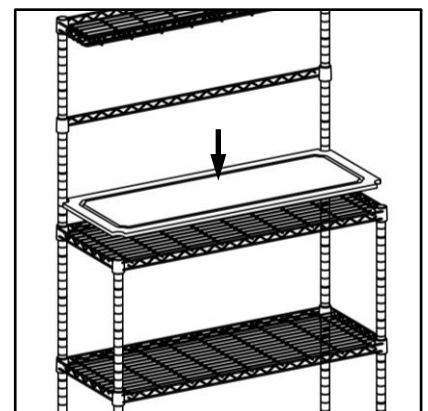

ASSEMBLY INSTRUCTIONS

STEP 6: INSTALLING HOOKS

Place the "S" HOOKS (F) onto the HANGING BAR (G) as desired. "S" HOOKS (F) can also be placed on the sides of the SHELVES (E).

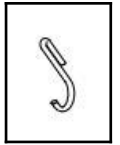

F (6)

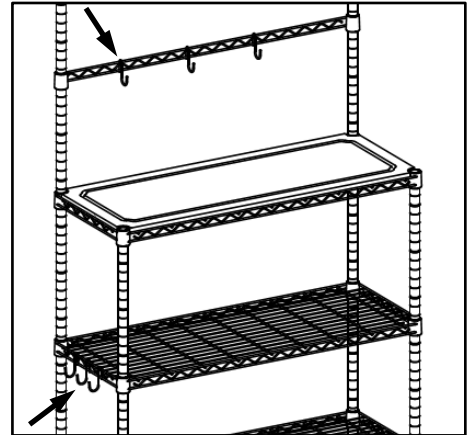

STEP 7: FEET LEVELERS

The Feet Levelers are already screwed into the FRONT BOTTOM POLES (A) and BACK BOTTOM POLES (A) and you can adjust as needed to ensure your Shelving Rack is level.

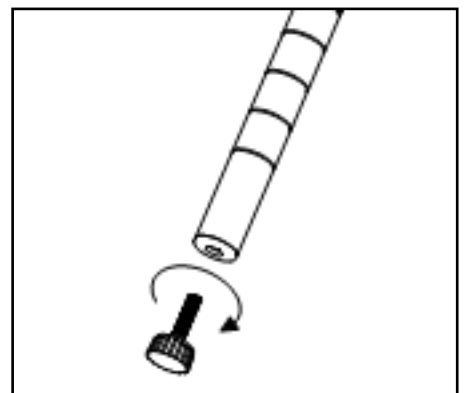

SERVICE PARTS LIST – TBFZ-1501

TRINITY Customer Service provides the following replacement parts:

Part Number	Description	Part Number	Description
1) ZSV-03-011-3607	Cantilever Shelf	7) ZSV-04-008-3400	Back Bottom Pole
2) XBK-01-011-2543	Slip Sleeve	8) ZSV-01-013-2523	Pole Connector
3) ONA-20-002-3513	Bamboo Board	9) ZSV-04-006-2475	Rear Top Pole
4) ZSV-03-093-3614	Shelf	10) ZSV-02-008-0001	"S" Hook
5) ZSV-04-009-3500	Front Pole	11) ZSV-02-007-0003	Hanging Bar
6) XBK-98-003-2538	Feet Leveler	12) XBK-23-004-2517	End Cap

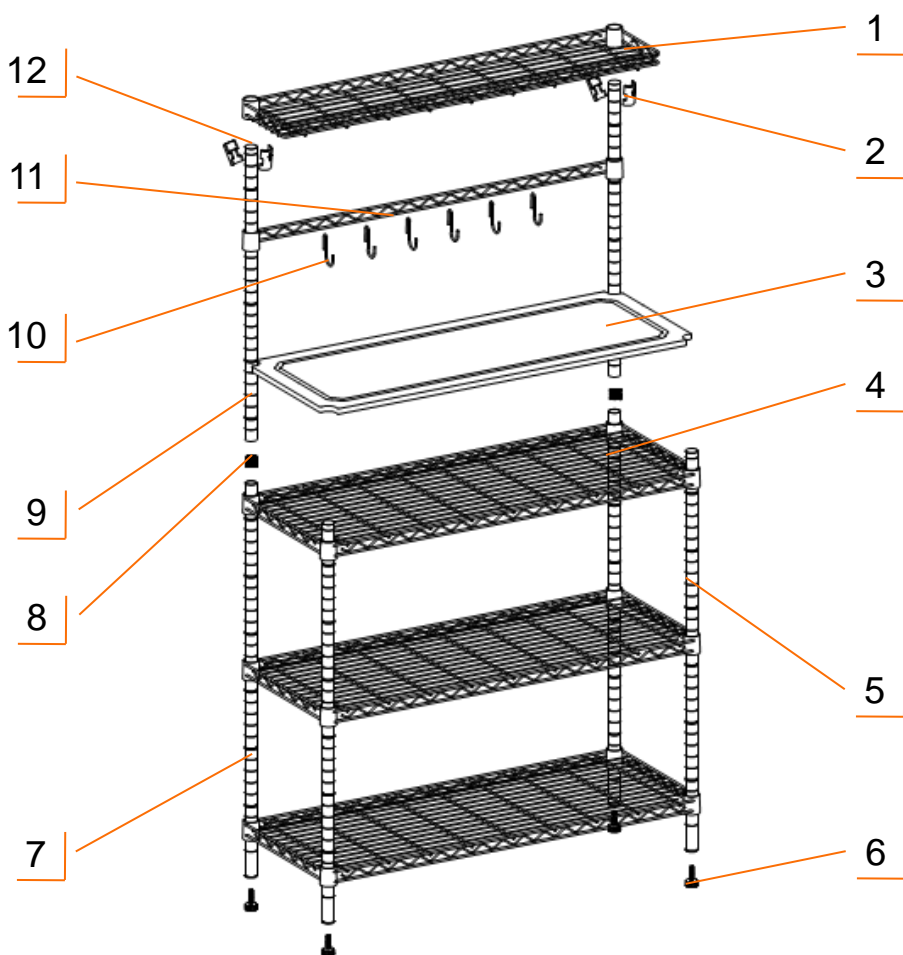

WARNINGS

1. **Read and understand all instructions.** Failure to follow all instructions may result in injury and/or damage.
2. **The warnings, cautions, and instructions discussed in this manual cannot cover all possible conditions or situations that may occur.** The user must always be aware of their environment and ensure that they use the product in a safe and responsible manner.
3. **Do NOT modify the product in any way.** Unauthorized modification may impair the function and/or safety of the product, and may affect the life of the product. Any modifications will void product warranty.
4. **Check for damaged parts.** Before using this product, carefully check that all parts are in good condition, and that the product will operate properly and perform its intended function. Check for damaged parts and any other conditions that may affect the operation of this product. Replace damaged or worn parts, and never use this product with a damaged part.
5. **Do NOT overload the product.**

Weight capacity per Shelf	250 lb (evenly distributed)
Weight capacity per Cantilever Shelf	25 lb (evenly distributed)
Total Weight capacity of Rack	1000 lb (evenly distributed)

6. **Do NOT allow children to climb or play around the product.** Tipping may occur causing injury.
7. **Load the product evenly and place the heaviest items on the lower shelves.**

CARE AND MAINTENANCE

- Avoid harsh, abrasive cleaners, and other corrosive chemicals.
- Bamboo board should be hand washed only and periodically treated with food safe oil.

PRODUCT REGISTRATION

Thank you for purchasing a TRINITY EcoStorage® Baker's Rack. In order to register your product and receive streamlined customer service, please fill out the following Product Registration Form and (1) fax the form to 310.347.4134 (2) complete the Product Registration Form online at www.trinityii.com or (3) scan and email the form to customerservice@trinityii.com. Include a copy of your original receipt with your submission.

First Name: _____ Last Name: _____

Address: _____

City: _____ State: _____ Zip Code: _____

Email Address: _____ Phone: _____

Product Model #: _____ TBFZ-1501 _____ Purchase Date: ____ / ____ / ____

Location of Purchase: _____

Please rate the importance of each feature (1=least important; 10=most important)

Quality ____ Price ____ Size/Capacity ____ Appearance ____ Other ____

How did you hear about our product?

- Magazine Ad Catalog Salesperson Word of Mouth
 Internet Store Display Other

Marital Status: Single Married

Household Income: Below \$50,000 \$50,000-\$150,000 \$150,000+

Education: High School College Graduate School

Primary Residence: Own Rent

Comments/Suggestions:



1 YEAR LIMITED WARRANTY

TRINITY EcoStorage® Baker's Rack Model # TBFZ-1501

Trinity International Industries ("Trinity") warrants to the original consumer purchaser ("Purchaser") of the TRINITY EcoStorage® Baker's Rack ("Product") that each Product shall be free from defects in workmanship and materials for a period of 1 year from the date of original purchase. Trinity's obligation under this warranty shall be limited to repair or replacement of, or adequate compensation for the Product which shall not be greater than the amount of the purchase price of the Product, at the option of Trinity, during the warranty period. All replaced parts and Products become the property of Trinity and must be returned to Trinity.

This warranty excludes normal wear and tear of the Product and its parts or components, and damage arising from any of the following: negligent use or misuse of the Product, use contrary to this User's Manual, or alteration by any one other than Trinity. The warranty period of 1 year shall not be extended or renewed by the repair or replacement of, or compensation for, the Product. Any warranty implied by applicable law is limited in duration to one year from the date of purchase and is subject to the same conditions and limitations as is provided for our express warranty.

Except as set forth herein, and to the extent of applicable there are no warranties on this Product either express or implied, and Trinity disclaims all warranties including, but not limited to, any implied warranties of merchantability, infringement or fitness for a particular purpose. No warranty or guarantee given by any person, firm, or corporation with respect to this product shall be binding on Trinity.

If your Product is defective or otherwise requires service or parts, please call TRINITY Customer Service toll-free at (800) 985-5506, between 5:00 a.m. and 5:00 p.m., PST. Please tell us which model you purchased, the date of the purchase, and the problem with your Product. A copy of your original purchase receipt must accompany your service request.

LIMITATION OF REMEDIES AND LIABILITY

Trinity (and its employees, officers, members, managers, affiliates and assigns) shall not be liable for any incidental, consequential, special, indirect, remote, special or punitive damages for breach of any warranty, express or implied, including, but not limited to, lost profits, lost savings, loss of anticipated benefits and attorneys' fees, which arise out of the purchase, use or inability to use the Product, whether arising out of contract, negligence, strict tort, product liability, or any other legal theory on which a claim is based. As noted above, to the extent damages are allowed by our express warranty or by applicable law, those damages may not exceed the purchase price paid for the Product. Without limiting the foregoing Purchaser assumes all risk and liability for loss, damage or injury to Purchaser and Purchaser's property and to others and their property arising out of the use, misuse, or inability to use this Product. This limited warranty shall not extend to anyone other than the original purchaser of this product, is nontransferable and states your exclusive remedy.

Some states do not allow the exclusion or limitation of incidental, consequential, special, or punitive damages, so the above limitation or exclusion may not apply to you. The above warranty gives you specific legal rights, and you may have other rights which vary from state to state.

CONTACT US

**QUESTIONS? NEED PARTS?
WE ARE HERE TO HELP!**

Please feel free to contact us. There are no questions too small, or any problems too big. We're committed to providing our customers with the highest level of service.

TRINITY Customer Service

TEL: 800.985.5506

FAX: 310.347.4134

EMAIL: customerservice@trinityii.com

**Monday through Friday
5:00 AM – 5:00 PM (PST)**

www.trinityii.com