

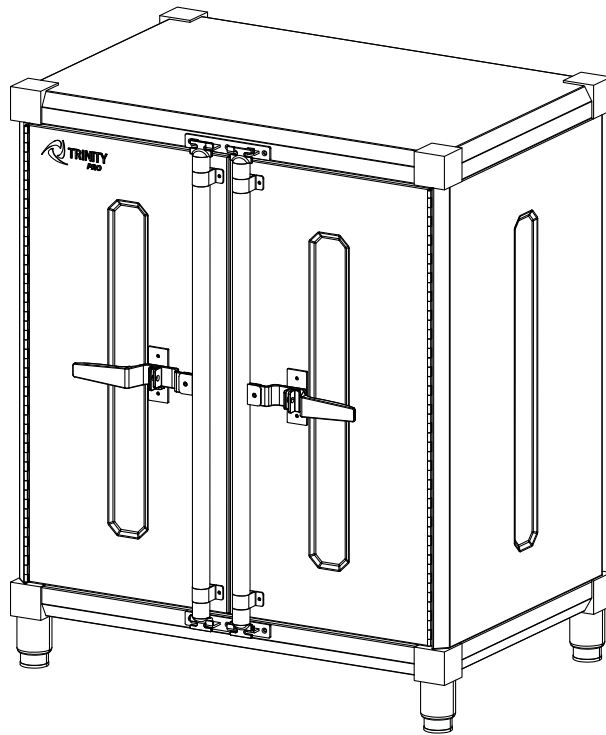

OWNER'S MANUAL



TRINITY PRO 28" BASE CABINET W/ DOORS
Model # TSNPBK-0608



PARTS LIST

Your TRINITY PRO 28" Base Cabinet w/Doors should include the following parts. Please inspect box contents to ensure you have received all components.

If you are missing any parts, need assistance with assembly or have questions, please contact TRINITY Customer Service: 800.985.5506 or customerservice@trinityii.com. Parts can also be requested online at www.trinityii.com (Help & More, Contact Us).

No tools required for assembly.

A

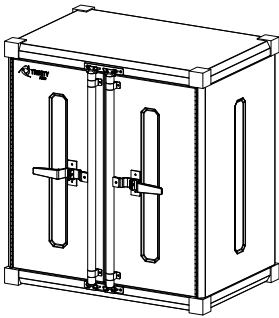

CABINET BODY (1)

B

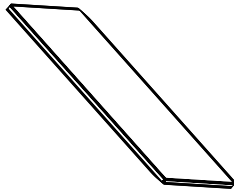

SHELF (2)

C



SHELF SUPPORT (8)

D

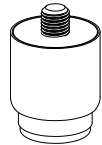

FEET LEVELER (4)

ASSEMBLY INSTRUCTIONS

STEP 1

Lay CABINET BODY (A) gently on its back. Two people are needed, Do NOT attempt this alone.

Screw FEET LEVELER (D) fully into each pre-installed nut on four corners of cabinet bottom.

Stand cabinet right side up. Move it to desired location. Adjust FEET LEVELER (D) as needed to ensure your cabinet is level and stable.

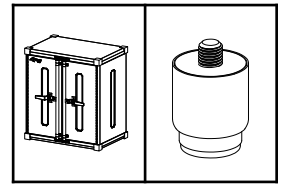
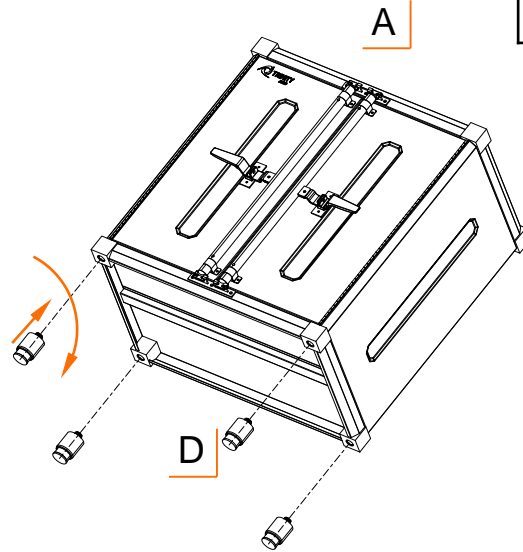

A (1)

D (4)

STEP 2

Attach SHELF SUPPORT (C) by hooking it over position tab at desired height. Make sure all four SHELF SUPPORTS (C) are at the same level.

Tilt SHELF (B) diagonally to move it inside cabinet. Place SHELF (B) on top of all four SHELF SUPPORTS (C).

Repeat above to install other shelf.

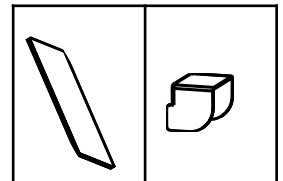

B (2)

C (8)

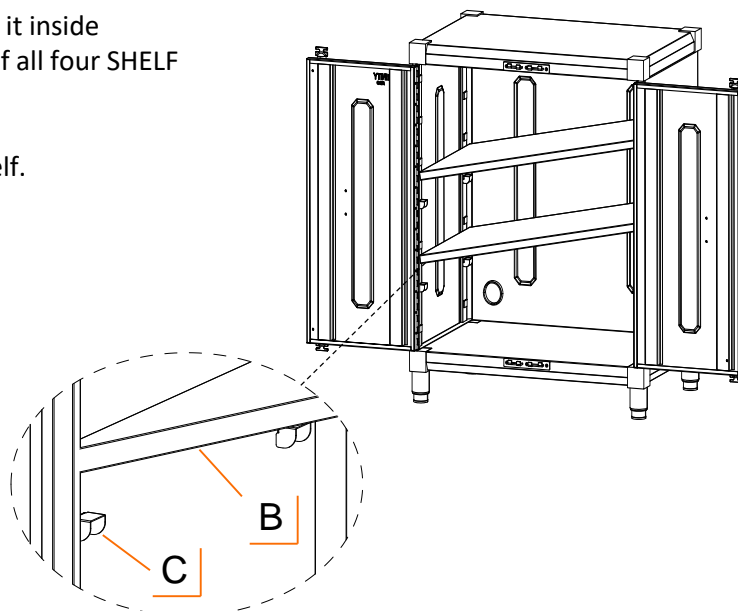

USAGE INSTRUCTIONS

OPEN AND CLOSE DOOR

Lift up door handle to release it from slot on handle base plate, rotate it forward and pull it to open door.

Close door by making sure ends of door bar is pushed against the stopper plate both on top and bottom. Rotate the door handle against door and slide into the slot on door handle base plate to keep door closed.

Note: To lock the door you need to buy a padlock with shackle diameter no larger than 9/32" (7mm). Put the shackle through the holes on door handle and handle base plate to lock the door.

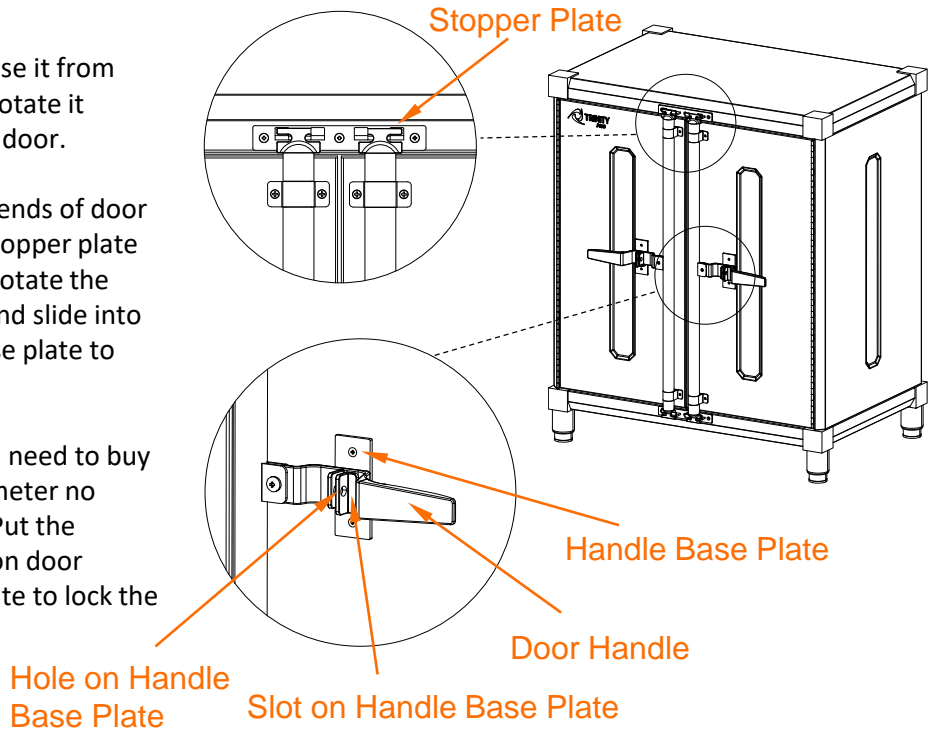

SHELF ADJUSTMENT

Ensure all items have been removed from shelf.

To adjust shelf height position, take shelf out of cabinet and re-attach shelf supports to position tabs at desired height.

Tilt shelf diagonally to move it inside cabinet. Place shelf on top of all shelf supports.

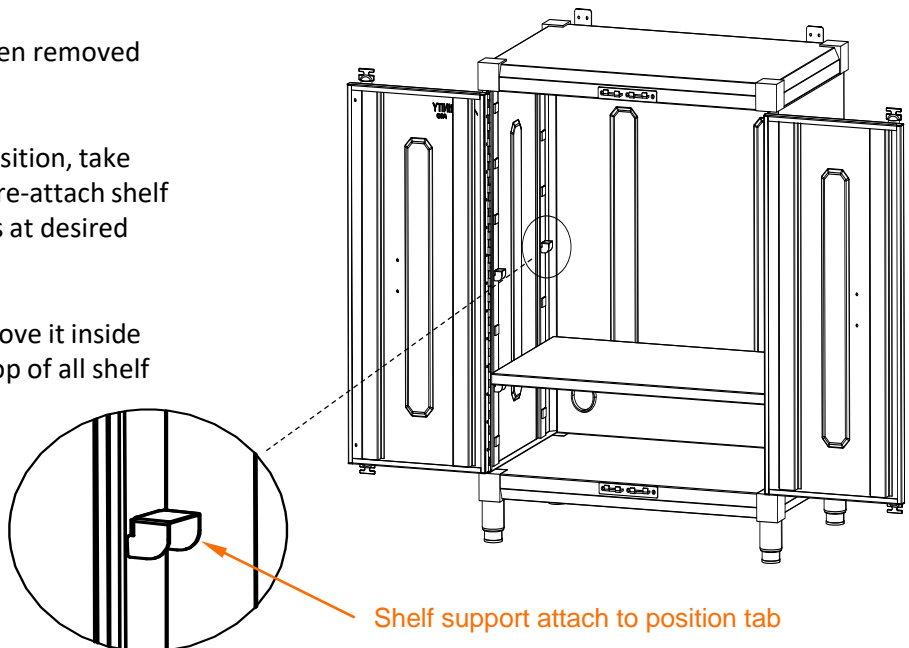

SERVICE PARTS LIST – TSNPBK-0608

TRINITY Customer Service provides the following replacement parts:

Part Number	Description	Part Number	Description
1) PBK-18-020-2819	Cabinet Body	9) XSV-02-017-0001	Shelf Support
2) XSV-09-009-0003	Door Hinge	10) XSV-01-010-0616	Handle Screw
3) XBS-02-030-0002	Right Handle Base Plate	11) XBS-02-030-0001	Left Handle Base Plate
4) XBS-05-025-0720	Handle	12) XSV-01-010-0408	Door Bar Bracket Screw
5) XBS-05-026-2875	Door Bar	13) XBK-02-028-0001	Plastic Spacer
6) XBS-02-029-0001	Door Bar Bracket	14) XBS-02-027-0001	Door Bar Stopper
7) XBS-98-012-1662	Feet Leveler	15) XSV-01-027-0408	Stopper Screw
8) PBK-03-073-1627	Shelf		

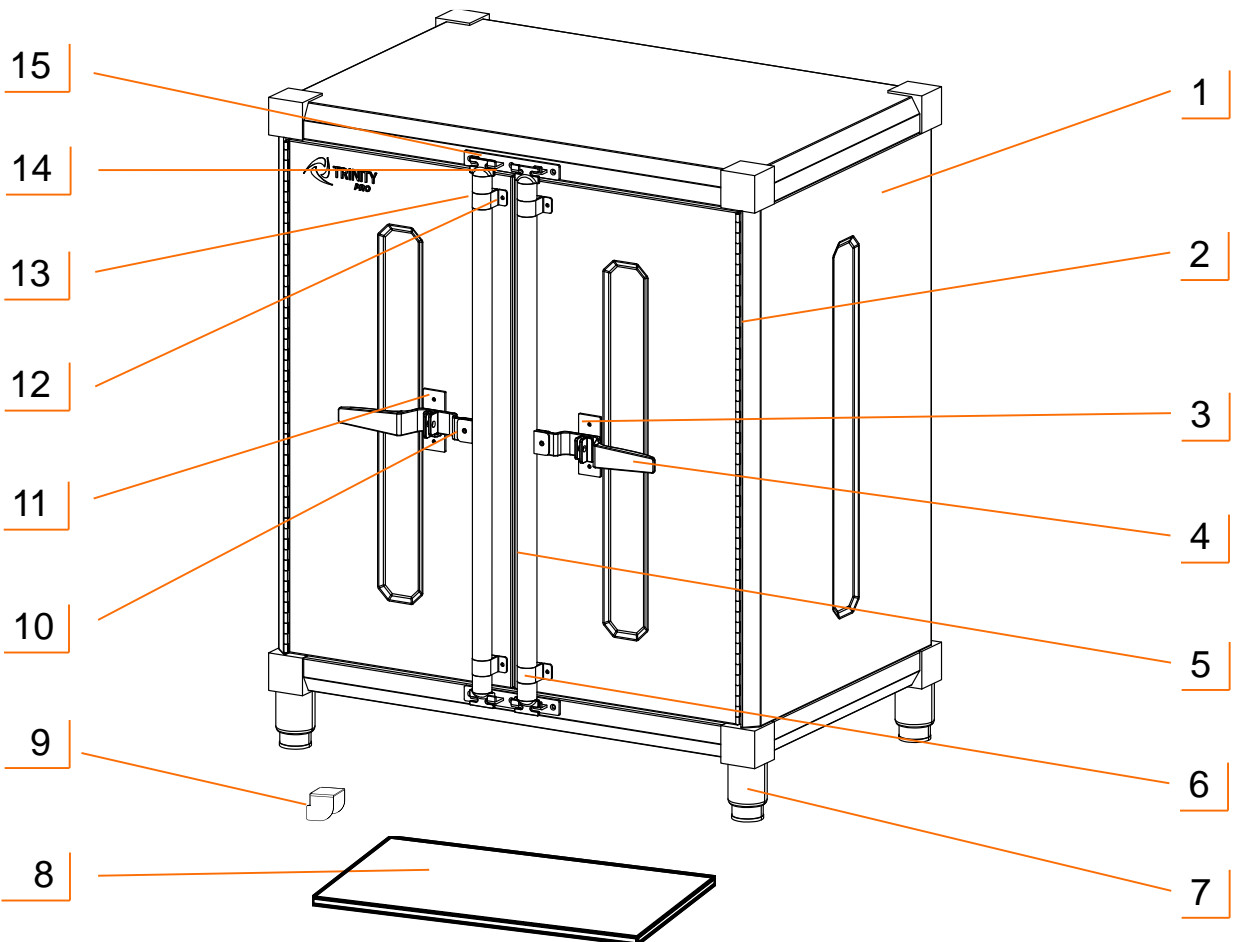

WARNINGS

1. **Read and understand all instructions.** Failure to follow all instructions may result in injury and/or damage.
2. **The warnings, cautions, and instructions discussed in this manual cannot cover all possible conditions or situations that may occur.** The user must always be aware of their environment and ensure that they use the product in a safe and responsible manner.
3. **Do NOT modify the product in any way.** Unauthorized modification may impair the function and/or safety of the product, and may affect the life of the product.
4. **Check for damaged parts.** Before using this product, carefully check that all parts are in good condition, and that the product will operate properly and perform its intended function. Check for damaged parts and any other conditions that may affect the operation of this product. Replace damaged or worn parts, and never use this product with a damaged part.
5. **Do NOT overload the product.**

Weight capacity per shelf (evenly distributed)	150 lb
Total weight capacity of cabinet (evenly distributed)	600 lb

CARE AND MAINTENANCE

- Avoid harsh, abrasive cleaners, and other corrosive chemicals.
- Do not use scouring pad for cleaning.
- This item is not certified for outdoor use.



PRODUCT REGISTRATION

Thank you for purchasing a TRINITY PRO 28" Base Cabinet w/Doors. In order to register your product and receive streamlined customer service, please fill out the following Product Registration Form and (1) fax the form to 310.347.4134 (2) complete the Product Registration Form online at www.trinityii.com or (3) scan and email the form to customerservice@trinityii.com. Include a copy of your original receipt with your submission.

First Name: _____ Last Name: _____

Address: _____

City: _____ State: _____ Zip Code: _____

Email Address: _____ Phone: _____

Product Model #: TSNPBK-0608 Purchase Date: ____ / ____ / ____

Location of Purchase: _____

Please rate the importance of each feature (1=least important; 10=most important)

Quality ____ Price ____ Size/Capacity ____ Appearance ____ Other ____

How did you hear about our product?

- Magazine Ad Catalog Salesperson Word of Mouth
 Internet Store Display Other

Marital Status: Single Married

Household Income: Below \$50,000 \$50,000-\$150,000 \$150,000+

Education: High School College Graduate School

Primary Residence: Own Rent

Comments/Suggestions:





1 YEAR LIMITED WARRANTY

TRINITY PRO 28" Base Cabinet w/Doors Model # TSNPBK-0608

Trinity International Industries ("Trinity") warrants to the original consumer purchaser ("Purchaser") of the TRINITY PRO 28" Base Cabinet w/Doors ("Product") that each Product shall be free from defects in workmanship and materials for a period of 1 year from the date of original purchase. Trinity's obligation under this warranty shall be limited to repair or replacement of, or adequate compensation for the Product which shall not be greater than the amount of the purchase price of the Product, at the option of Trinity, during the warranty period. All replaced parts and Products become the property of Trinity and must be returned to Trinity.

This warranty excludes normal wear and tear of the Product and its parts or components, and damage arising from any of the following: negligent use or misuse of the Product, use contrary to this User's Manual, or alteration by any one other than Trinity. The warranty period of 1 year shall not be extended or renewed by the repair or replacement of, or compensation for, the Product. Any warranty implied by applicable law is limited in duration to one year from the date of purchase and is subject to the same conditions and limitations as is provided for our express warranty.

Except as set forth herein, and to the extent of applicable there are no warranties on this Product either express or implied, and Trinity disclaims all warranties including, but not limited to, any implied warranties of merchantability, infringement or fitness for a particular purpose. No warranty or guarantee given by any person, firm, or corporation with respect to this product shall be binding on Trinity.

If your Product is defective or otherwise requires service or parts, please call TRINITY Customer Service toll-free at (800) 985-5506, between 5:00 a.m. and 5:00 p.m., PST. Please tell us which model you purchased, the date of the purchase, and the problem with your Product. A copy of your original purchase receipt must accompany your service request.

LIMITATION OF REMEDIES AND LIABILITY

Trinity (and its employees, officers, members, managers, affiliates and assigns) shall not be liable for any incidental, consequential, special, indirect, remote, special or punitive damages for breach of any warranty, express or implied, including, but not limited to, lost profits, lost savings, loss of anticipated benefits and attorneys' fees, which arise out of the purchase, use or inability to use the Product, whether arising out of contract, negligence, strict tort, product liability, or any other legal theory on which a claim is based. As noted above, to the extent damages are allowed by our express warranty or by applicable law, those damages may not exceed the purchase price paid for the Product. Without limiting the foregoing Purchaser assumes all risk and liability for loss, damage or injury to Purchaser and Purchaser's property and to others and their property arising out of the use, misuse, or inability to use this Product. This limited warranty shall not extend to anyone other than the original purchaser of this product, is nontransferable and states your exclusive remedy.

Some states do not allow the exclusion or limitation of incidental, consequential, special, or punitive damages, so the above limitation or exclusion may not apply to you. The above warranty gives you specific legal rights, and you may have other rights which vary from state to state.

CONTACT US

**QUESTIONS? NEED PARTS?
WE ARE HERE TO HELP!**

Please feel free to contact us. There are no questions too small, or any problems too big. We're committed to providing our customers with the highest level of service.

TRINITY Customer Service

TEL: 800.985.5506

FAX: 310.347.4134

EMAIL: customerservice@trinityii.com

**Monday through Friday
5:00 AM – 5:00 PM (PST)**

www.trinityii.com



OWNER'S MANUAL

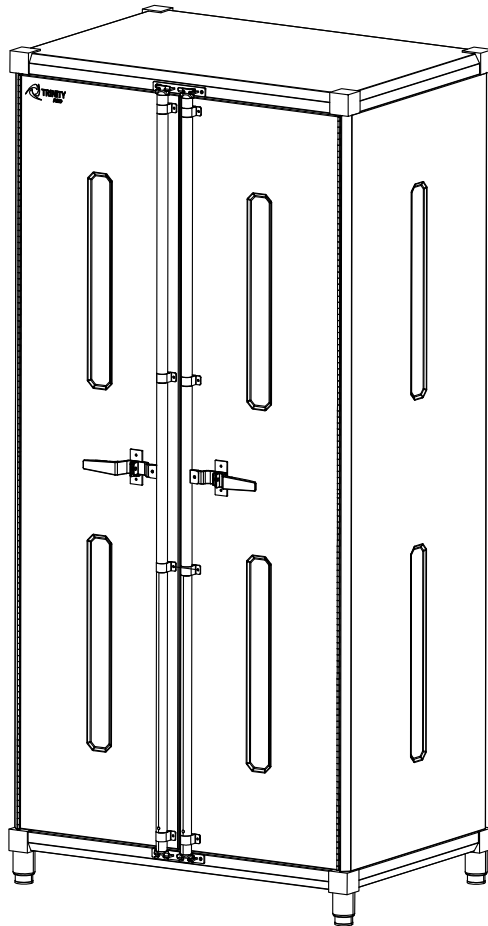

TRINITY PRO 36" LOCKER CABINET
Model # TSNPBK-0610



PARTS LIST

Your TRINITY PRO 36" Locker Cabinet should include the following parts. Please inspect box contents to ensure you have received all components.

If you are missing any parts, need assistance with assembly or have questions, please contact TRINITY Customer Service: 800.985.5506 or customerservice@trinityii.com. Parts can also be requested online at www.trinityii.com (Help & More, Contact Us).

No tools required for assembly.

A

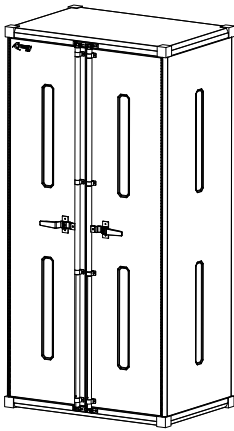

CABINET BODY (1)

B

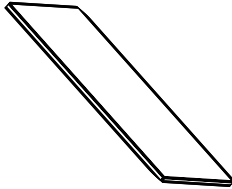

SHELF (3)

C



SHELF SUPPORT (12)

D

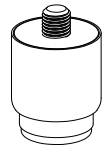

FEET LEVELER (4)

ASSEMBLY INSTRUCTIONS

STEP 1

Lay CABINET BODY (A) gently on its back. Two people are needed, do NOT attempt this alone.

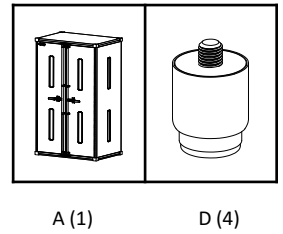

Screw FEET LEVELER (D) fully into each pre-installed nut on four corners of cabinet bottom.

Stand cabinet right side up. Move it to desired location. Adjust FEET LEVELER (D) as needed to ensure your cabinet is level and stable.

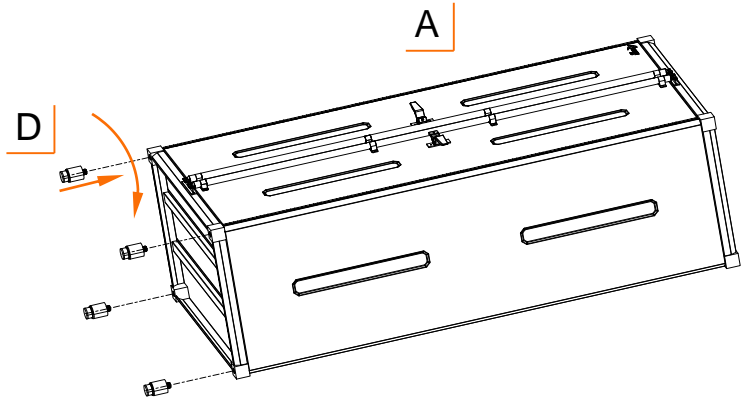

STEP 2

Attach SHELF SUPPORT (C) by hooking it over position tab at desired height. Make sure all four SHELF SUPPORTS (C) are at same level.

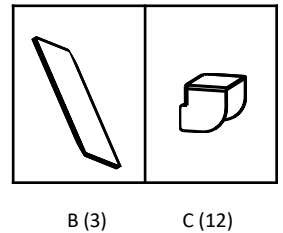

Tilt SHELF (B) diagonally to move it inside cabinet. Place SHELF (B) on top of all four SHELF SUPPORTS (C).

Repeat above to install remaining shelves.

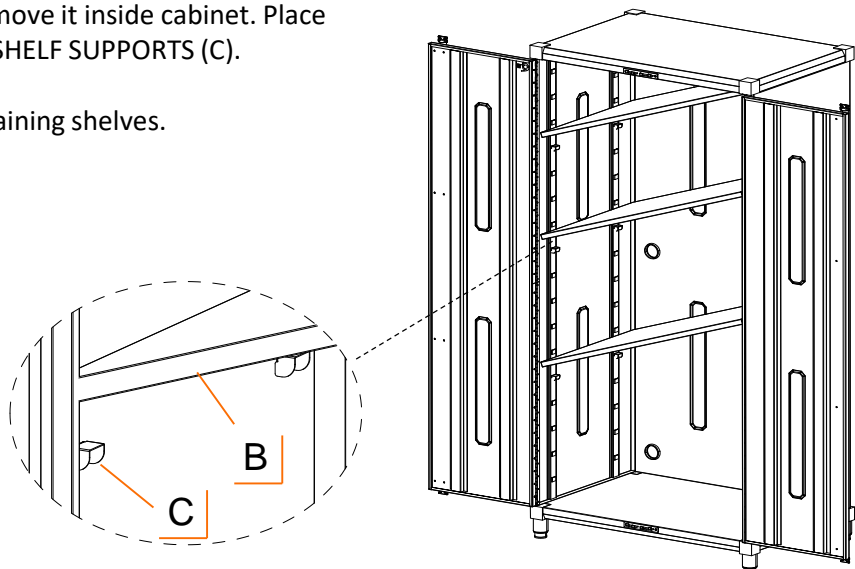

USAGE INSTRUCTIONS

OPEN AND CLOSE DOOR

Lift up door handle to release it from slot on handle base plate, rotate it forward and pull it to open door.

Close door by making sure ends of door bar is pushed against the stopper plate both on top and bottom. Rotate the door handle against door and slide into the slot on door handle base plate to keep door closed.

Note: To lock the door you need to buy a padlock with shackle diameter no larger than 9/32" (7mm). Put the shackle through the holes on door handle and handle base plate to lock the door.

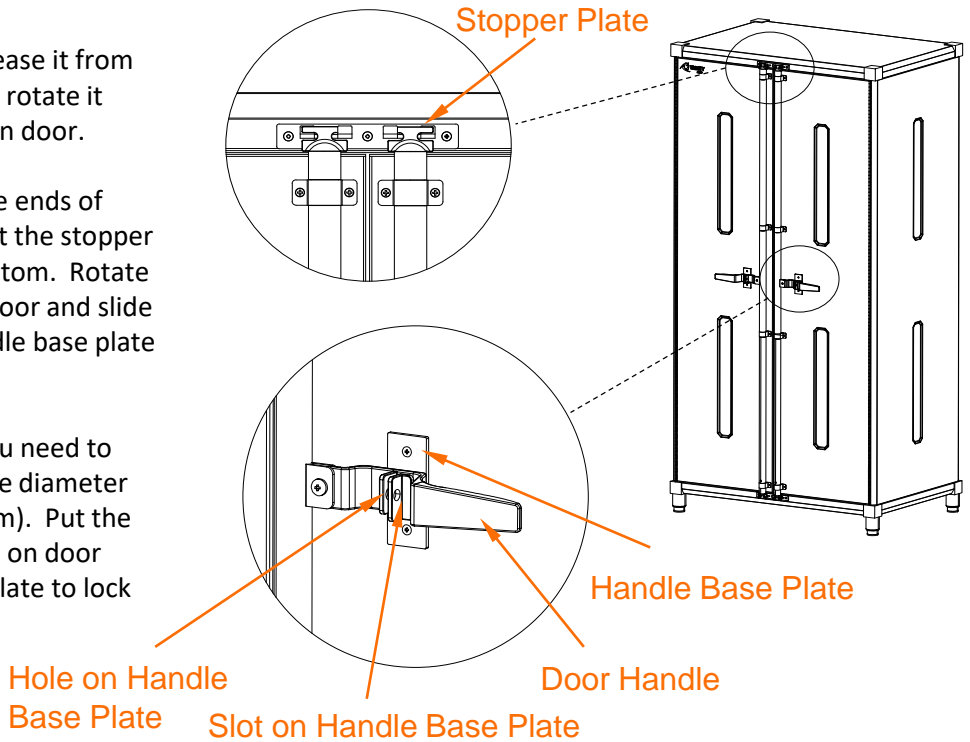

SHELF ADJUSTMENT

Ensure all items have been removed from shelf.

To adjust shelf height position, take shelf out of cabinet, re-attach shelf supports to position tabs at desired height.

Tilt shelf diagonally to move it inside cabinet. Place shelf on top of all shelf supports.

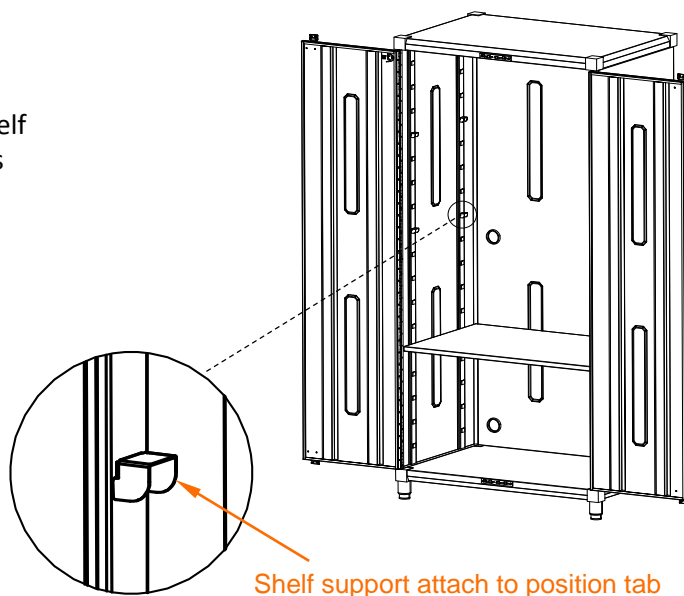

SERVICE PARTS LIST – TSNPBK-0610

TRINITY Customer Service provides the following replacement parts:

Part Number	Description	Part Number	Description
1) PBK-18-020-3624	Cabinet Body	9) XSV-02-017-0001	Shelf Support
2) XSV-09-009-0004	Door Hinge	10) XSV-01-010-0616	Handle Screw
3) XBS-02-030-0002	Right Handle Base Plate	11) XBS-02-030-0001	Left Handle Base Plate
4) XBS-05-025-0720	Handle	12) XSV-01-010-0408	Door Bar Bracket Screw
5) XBS-02-029-0001	Door Bar Bracket	13) XBK-02-028-0001	Plastic Spacer
6) XBS-05-026-2875	Door Bar	14) XBS-02-027-0001	Door Bar Stopper
7) XBS-98-012-1662	Feet Leveler	15) XSV-01-027-0408	Stopper Screw
8) PBK-03-073-2235	Shelf		

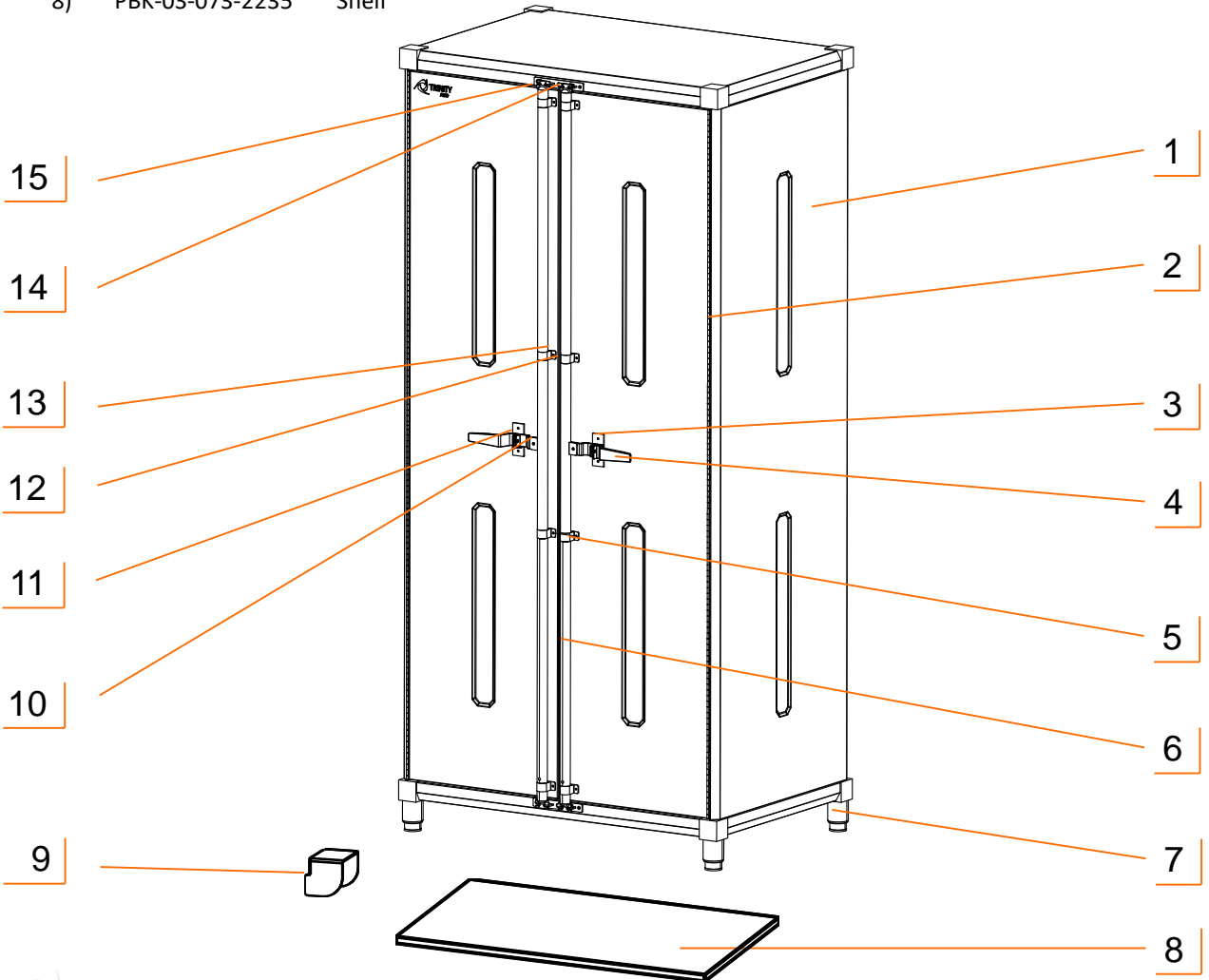

WARNINGS

1. **Read and understand all instructions.** Failure to follow all instructions may result in injury and/or damage.
2. **The warnings, cautions, and instructions discussed in this manual cannot cover all possible conditions or situations that may occur.** The user must always be aware of their environment and ensure that they use the product in a safe and responsible manner.
3. **Do NOT modify the product in any way.** Unauthorized modification may impair the function and/or safety of the product, and may affect the life of the product.
4. **Check for damaged parts.** Before using this product, carefully check that all parts are in good condition, and that the product will operate properly and perform its intended function. Check for damaged parts and any other conditions that may affect the operation of this product. Replace damaged or worn parts, and never use this product with a damaged part.
5. **Do NOT overload the product.**

Weight capacity per shelf (evenly distributed)	200 lb
Total weight capacity of cabinet (evenly distributed)	1000 lb

CARE AND MAINTENANCE

- Avoid harsh, abrasive cleaners, and other corrosive chemicals.
- Do not use scouring pad for cleaning.
- This item is not certified for outdoor use.





1 YEAR LIMITED WARRANTY

TRINITY PRO 36" Locker Cabinet Model # TSNPBK-0610

Trinity International Industries ("Trinity") warrants to the original consumer purchaser ("Purchaser") of the TRINITY PRO 36" Locker Cabinet ("Product") that each Product shall be free from defects in workmanship and materials for a period of 1 year from the date of original purchase. Trinity's obligation under this warranty shall be limited to repair or replacement of, or adequate compensation for the Product which shall not be greater than the amount of the purchase price of the Product, at the option of Trinity, during the warranty period. All replaced parts and Products become the property of Trinity and must be returned to Trinity.

This warranty excludes normal wear and tear of the Product and its parts or components, and damage arising from any of the following: negligent use or misuse of the Product, use contrary to this User's Manual, or alteration by any one other than Trinity. The warranty period of 1 year shall not be extended or renewed by the repair or replacement of, or compensation for, the Product. Any warranty implied by applicable law is limited in duration to one year from the date of purchase and is subject to the same conditions and limitations as is provided for our express warranty.

Except as set forth herein, and to the extent of applicable there are no warranties on this Product either express or implied, and Trinity disclaims all warranties including, but not limited to, any implied warranties of merchantability, infringement or fitness for a particular purpose. No warranty or guarantee given by any person, firm, or corporation with respect to this product shall be binding on Trinity.

If your Product is defective or otherwise requires service or parts, please call TRINITY Customer Service toll-free at (800) 985-5506, between 5:00 a.m. and 5:00 p.m., PST. Please tell us which model you purchased, the date of the purchase, and the problem with your Product. A copy of your original purchase receipt must accompany your service request.

LIMITATION OF REMEDIES AND LIABILITY

Trinity (and its employees, officers, members, managers, affiliates and assigns) shall not be liable for any incidental, consequential, special, indirect, remote, special or punitive damages for breach of any warranty, express or implied, including, but not limited to, lost profits, lost savings, loss of anticipated benefits and attorneys' fees, which arise out of the purchase, use or inability to use the Product, whether arising out of contract, negligence, strict tort, product liability, or any other legal theory on which a claim is based. As noted above, to the extent damages are allowed by our express warranty or by applicable law, those damages may not exceed the purchase price paid for the Product. Without limiting the foregoing Purchaser assumes all risk and liability for loss, damage or injury to Purchaser and Purchaser's property and to others and their property arising out of the use, misuse, or inability to use this Product. This limited warranty shall not extend to anyone other than the original purchaser of this product, is nontransferable and states your exclusive remedy.

Some states do not allow the exclusion or limitation of incidental, consequential, special, or punitive damages, so the above limitation or exclusion may not apply to you. The above warranty gives you specific legal rights, and you may have other rights which vary from state to state.

CONTACT US

**QUESTIONS? NEED PARTS?
WE ARE HERE TO HELP!**

Please feel free to contact us. There are no questions too small, or any problems too big. We're committed to providing our customers with the highest level of service.

TRINITY Customer Service

TEL: 800.985.5506

FAX: 310.347.4134

EMAIL: customerservice@trinityii.com

**Monday through Friday
5:00 AM – 5:00 PM (PST)**

www.trinityii.com



OWNER'S MANUAL

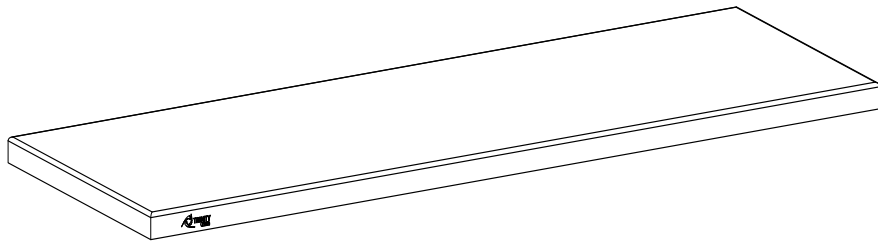

TRINITY PRO 56" x 19" WOOD TOP
Model # TSLNA-4898



PARTS LIST

Your TRINITY PRO 56" x 19" Wood Top can be mounted on top of the TRINITY PRO Base Cabinet. To install it requires one of the following parts kit for assembly which are included in TRINITY PRO Base Cabinet hardware package. Please inspect box contents to ensure you have received all components. You will also need a Phillips screwdriver for assembly which is not provided.

If you are missing any parts, need assistance with assembly or have questions, please contact TRINITY Customer Service: 800.985.5506 or customerservice@trinityii.com. Parts can also be requested online at www.trinityii.com (Help & More, Contact Us).

Option 1 Hardware Parts (Included inside each Base Cabinet of a 4-piece Set)

A

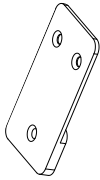

WOOD TOP BRACKET (2)

B



WOOD SCREW (4)
M4X16

C



CABINET SCREW (2)
M4X8

Option 2 Hardware Parts (Included inside the Base Cabinet of a 5-piece Set)

A

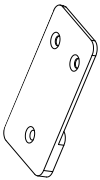

WOOD TOP BRACKET (2)

B



WOOD SCREW (8)
M4X16

C



CABINET SCREW (2)
M4X8

D

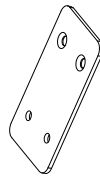

WALL BRACKET (2)

E



WALL ANCHOR (4)

F



WALL SCREW (4)
M4X25

Note: 4-piece Set does not include Wall Mounting Hardware (D), (E) and (F). They can be purchased as a Wall Mounting Hardware Kit (PBK-02-011-0014) through our website or our customer service number.

ASSEMBLY INSTRUCTIONS

Option 1 (Installed on 2 Base Cabinets)

Stand two assembled TRINITY PRO Base Cabinets side by side and close to final location of where cabinets will be placed.

Position a TRINITY PRO 56" x 19" WOOD TOP on top of aligned base cabinets. Make sure logo on Wood Top edge is upright and front facing on cabinets.

Align Wood Top edges to Base Cabinets top edges. Place WOOD TOP BRACKET (A) on back corner of each cabinet. Align bottom hole on WOOD TOP BRACKET (A) to each pre-installed nut on back corner of cabinet. Insert CABINET SCREW (C) into each bottom hole and tighten them fully to cabinet with a Philips screwdriver.

Insert WOOD SCREW (B) into each top hole and tighten them fully to Wood Top edge with a Philips screwdriver.

With 2 people, carefully slide entire assembly into final location. Do NOT lift assembly by Wood Top.

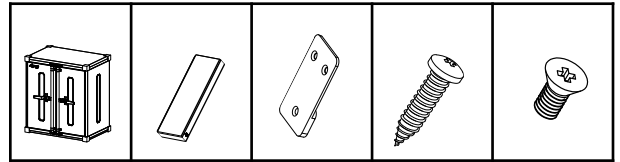

Base Cabinet (2) Wood Top (1) A (4) B (8) C (4)

TRINITY PRO LOGO on front side of cabinet

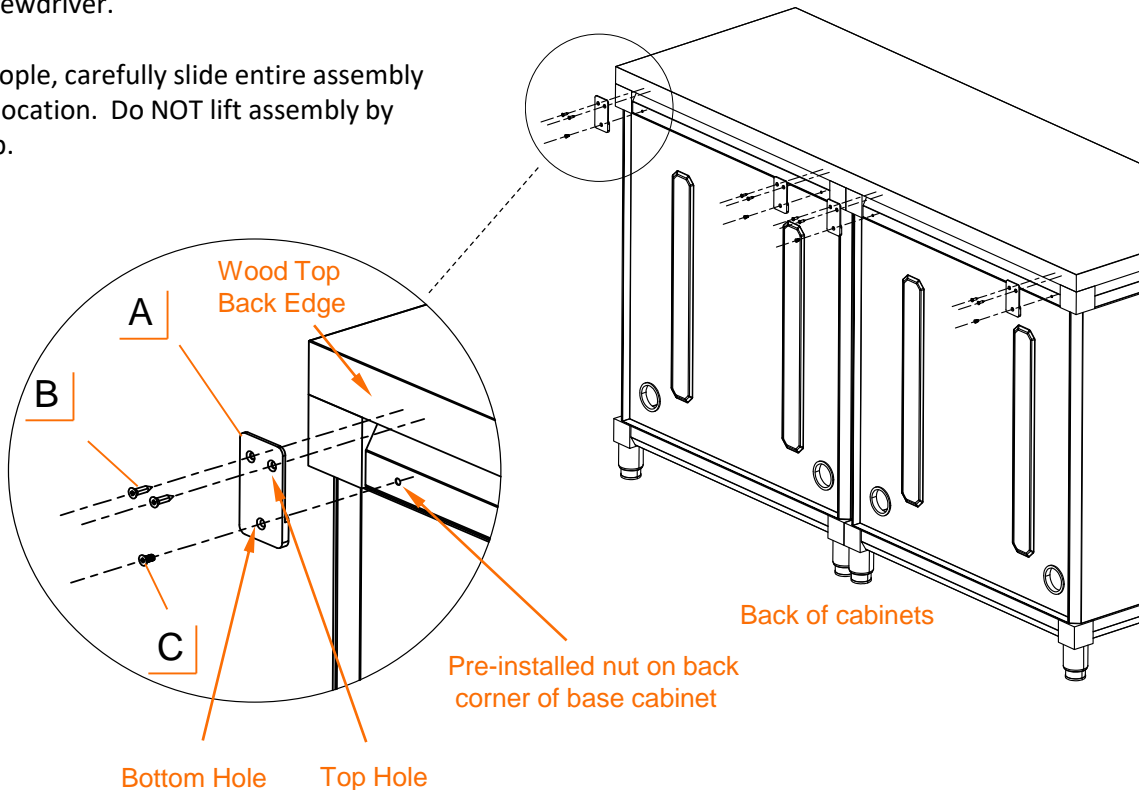
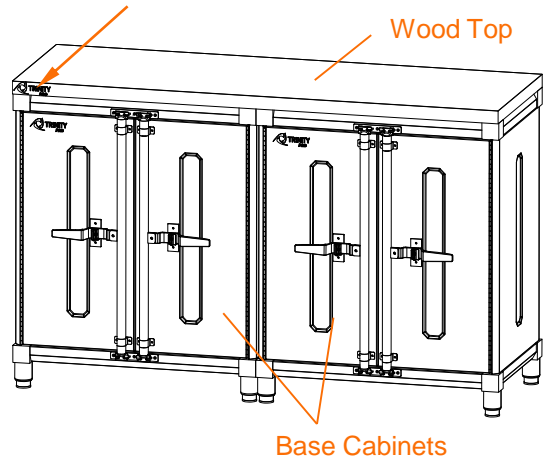

ASSEMBLY INSTRUCTIONS

Option 2 (Installed on 1 Base Cabinet)

Move TRINITY PRO Base Cabinet close to final location where it will be placed. With 2 people, position a TRINITY PRO 56" x 19" WOOD TOP on top of an assembled base cabinet as shown. Make sure logo on wood top edge is upright and front facing on cabinet.

Place WOOD TOP BRACKET (A) on back corner of cabinet. Align bottom hole on WOOD TOP BRACKET (A) to each pre-installed nut on back corner of cabinet. Insert CABINET SCREW (C) into each bottom hole and tighten them fully to cabinet with a Philips screwdriver.

Insert WOOD SCREW (B) into each top hole and tighten them fully to wood top edge with a Philips screwdriver.

Note: 4-piece Set does not include Wall Mounting Hardware. If you desire set up in this configuration you will need to buy a Wall Mounting Hardware Kit (PBK-02-011-0014) which is available for purchase through our website or our customer service number.

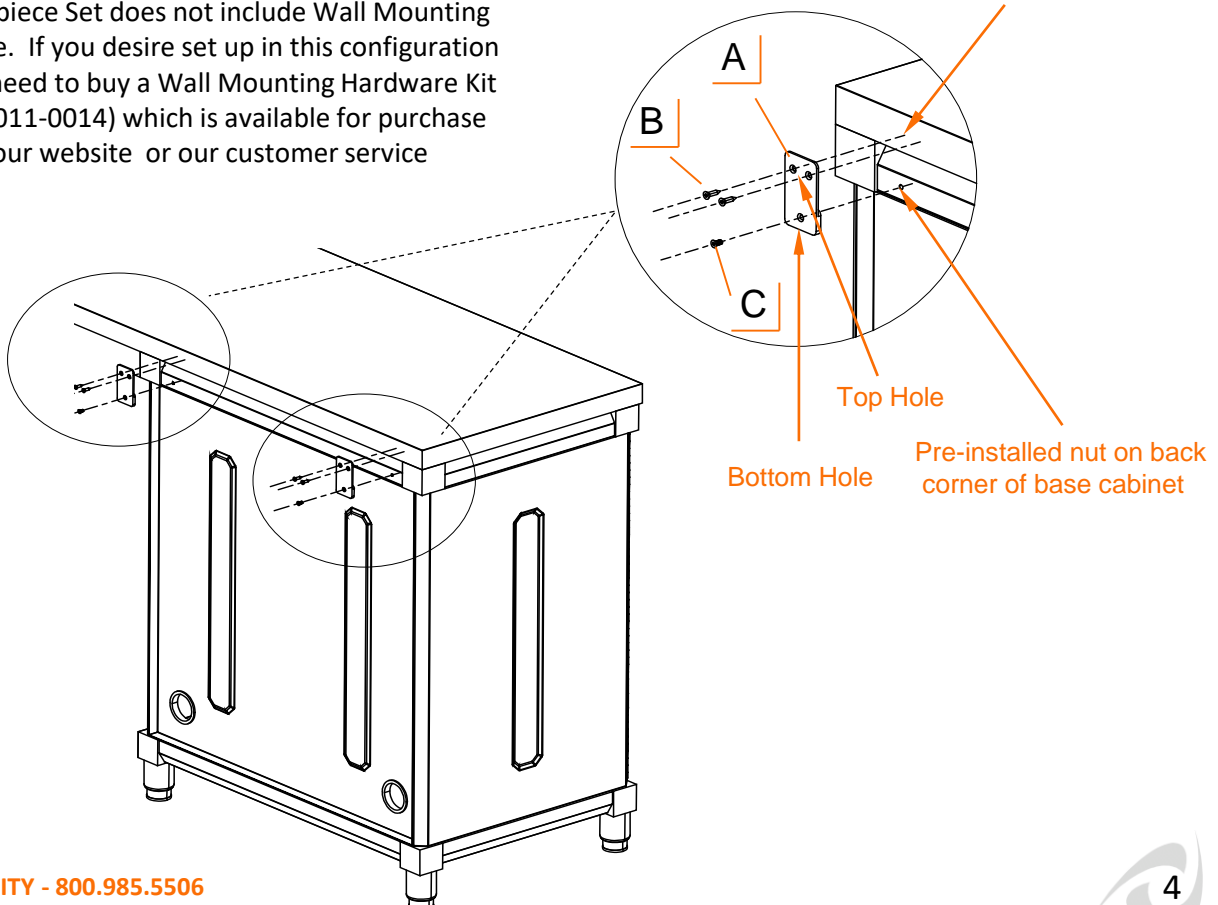
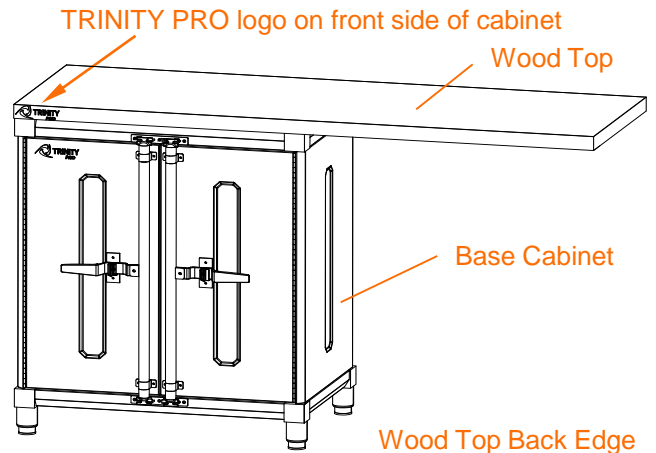
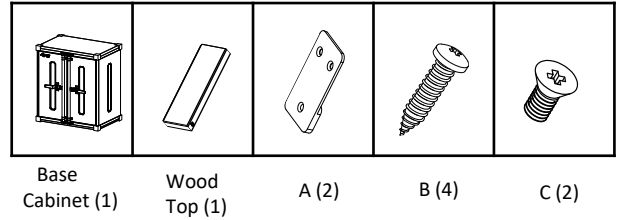

ASSEMBLY INSTRUCTIONS

Option 2 (Installed on 1 Base Cabinet)

Place two WALL BRACKETS (D) to other end of back edge of Wood Top as shown. Make sure one bracket is as close as possible to end of unsupported end of wood top. Insert WOOD SCREW (B) into each top hole and tighten them fully to wood top edge with a Philips screwdriver.

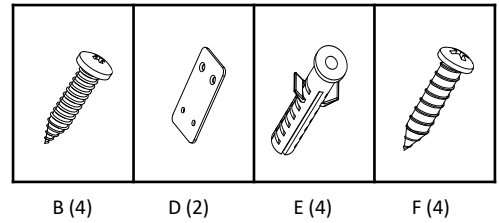

With 2 people, carefully slide assembled unit to wall at desired location. Do NOT lift assembly by wood top.

Mark off mounting location on wall through bottom holes on WALL BRACKET (D). If WALL ANCHORS (E) are required, drill holes in marked locations. Insert WALL ANCHOR (E) completely into each drilled hole.

Fasten WALL SCREWS (F) through bottom holes on WALL BRACKET (D) into the wall or anchors tightly with a Philips screwdriver.

Note: Please consult a local contractor if you are unsure if your wall is able to bear the load of the Wood Top.

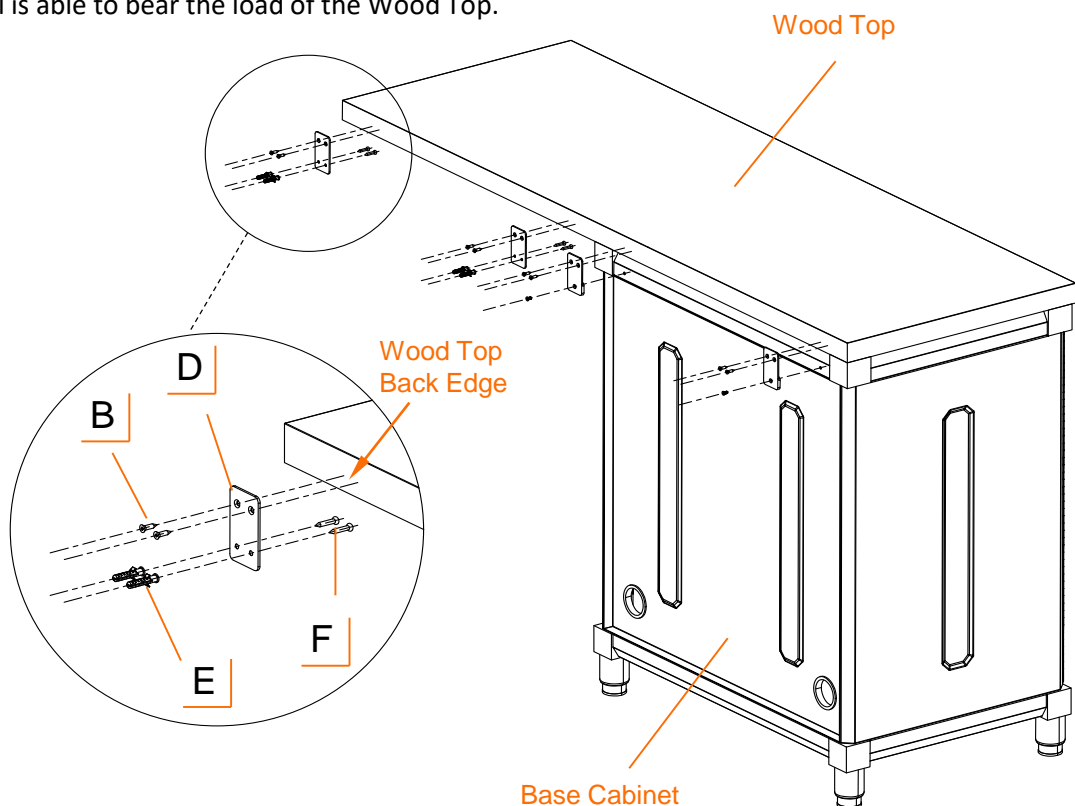

SERVICE PARTS LIST

TRINITY Customer Service provides the following replacement parts:

	Part Number	Description		Part Number	Description
1)	XSV-01-036-0425	Wall Screw	4)	XSV-01-027-0408	Cabinet Screw
2)	XGR-01-032-0525	Wall Anchor	5)	PBK-19-009-0300	Wood Top Bracket
3)	XSV-01-036-0416	Wood Screw	6)	PBK-19-010-0300	Wall Bracket

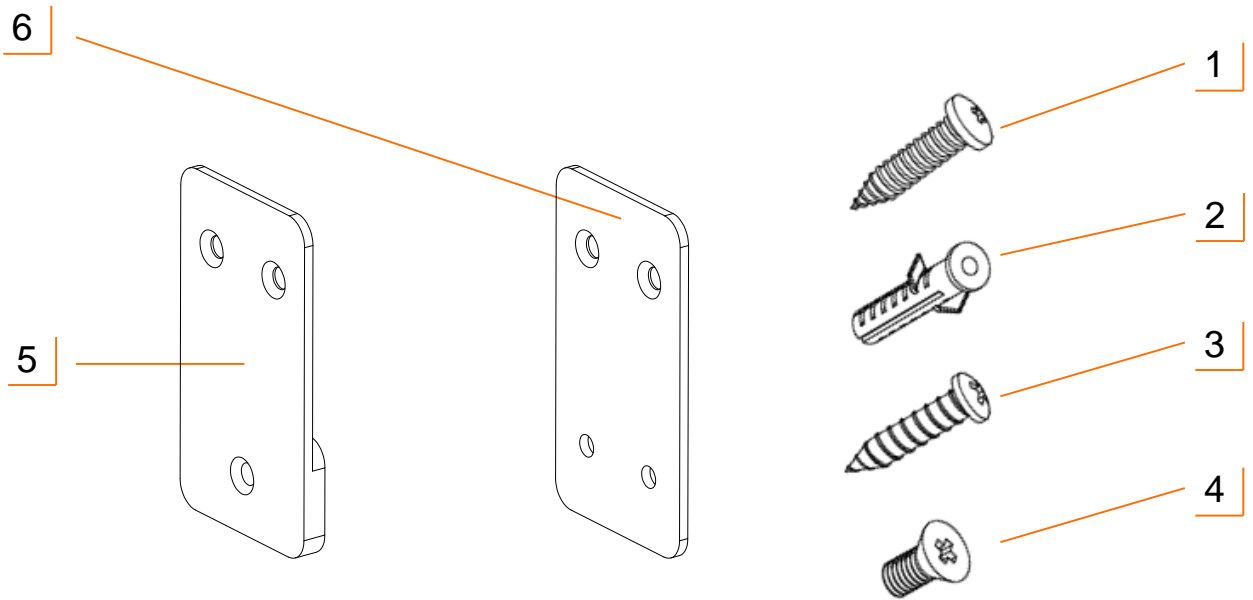

WARNINGS

1. **Read and understand all instructions.** Failure to follow all instructions may result in injury and/or damage.
2. **The warnings, cautions, and instructions discussed in this manual cannot cover all possible conditions or situations that may occur.** The user must always be aware of their environment and ensure that they use the product in a safe and responsible manner.
3. **Do NOT modify the product in any way.** Unauthorized modification may impair the function and/or safety of the product, and may affect the life of the product.
4. **Check for damaged parts.** Before using this product, carefully check that all parts are in good condition, and that the product will operate properly and perform its intended function. Check for damaged parts and any other conditions that may affect the operation of this product. Replace damaged or worn parts, and never use this product with a damaged part.
5. **Do NOT overload the product.**

Weight capacity on wood top in Option 1 configuration (evenly distributed)	600 lb
Weight capacity on wood top in Option 2 configuration (evenly distributed)	300 lb

6. **Do NOT use wood top unless it is securely attached.** All screws must be fastened tightly. Check regularly to ensure the screws have not loosened during use of wood top.

CARE AND MAINTENANCE

- Avoid harsh, abrasive cleaners, and other corrosive chemicals.
- Do not use scouring pad for cleaning.
- Clean up any spills immediately to prevent stains from forming on the wood top.
- Wood top can be cleaned with damp cloth and wiped dry immediately with dry cloth. If needed, solvent-based wood furniture cleaner can be used.

PRODUCT REGISTRATION

Thank you for purchasing a TRINITY PRO 56" x 19" Wood Top. In order to register your product and receive streamlined customer service, please fill out the following Product Registration Form and (1) fax the form to 310.347.4134 (2) complete the Product Registration Form online at www.trinityii.com or (3) scan and email the form to customerservice@trinityii.com. Include a copy of your original receipt with your submission.

First Name: _____ Last Name: _____

Address: _____

City: _____ State: _____ Zip Code: _____

Email Address: _____ Phone: _____

Product Model #: TLSLNA-4898 Purchase Date: ____ / ____ / ____

Location of Purchase: _____

Please rate the importance of each feature (1=least important; 10=most important)

Quality ____ Price ____ Size/Capacity ____ Appearance ____ Other ____

How did you hear about our product?

- Magazine Ad Catalog Salesperson Word of Mouth
 Internet Store Display Other

Marital Status: Single Married

Household Income: Below \$50,000 \$50,000-\$150,000 \$150,000+

Education: High School College Graduate School

Primary Residence: Own Rent

Comments/Suggestions:





1 YEAR LIMITED WARRANTY

TRINITY PRO 56" x 19" Wood Top Model # TLSLNA-4898

Trinity International Industries ("Trinity") warrants to the original consumer purchaser ("Purchaser") of the TRINITY PRO 56" x 19" Wood Top ("Product") that each Product shall be free from defects in workmanship and materials for a period of 1 year from the date of original purchase. Trinity's obligation under this warranty shall be limited to repair or replacement of, or adequate compensation for the Product which shall not be greater than the amount of the purchase price of the Product, at the option of Trinity, during the warranty period. All replaced parts and Products become the property of Trinity and must be returned to Trinity.

This warranty excludes normal wear and tear of the Product and its parts or components, and damage arising from any of the following: negligent use or misuse of the Product, use contrary to this User's Manual, or alteration by any one other than Trinity. The warranty period of 1 year shall not be extended or renewed by the repair or replacement of, or compensation for, the Product. Any warranty implied by applicable law is limited in duration to one year from the date of purchase and is subject to the same conditions and limitations as is provided for our express warranty.

Except as set forth herein, and to the extent of applicable there are no warranties on this Product either express or implied, and Trinity disclaims all warranties including, but not limited to, any implied warranties of merchantability, infringement or fitness for a particular purpose. No warranty or guarantee given by any person, firm, or corporation with respect to this product shall be binding on Trinity.

If your Product is defective or otherwise requires service or parts, please call TRINITY Customer Service toll-free at (800) 985-5506, between 5:00 a.m. and 5:00 p.m., PST. Please tell us which model you purchased, the date of the purchase, and the problem with your Product. A copy of your original purchase receipt must accompany your service request.

LIMITATION OF REMEDIES AND LIABILITY

Trinity (and its employees, officers, members, managers, affiliates and assigns) shall not be liable for any incidental, consequential, special, indirect, remote, special or punitive damages for breach of any warranty, express or implied, including, but not limited to, lost profits, lost savings, loss of anticipated benefits and attorneys' fees, which arise out of the purchase, use or inability to use the Product, whether arising out of contract, negligence, strict tort, product liability, or any other legal theory on which a claim is based. As noted above, to the extent damages are allowed by our express warranty or by applicable law, those damages may not exceed the purchase price paid for the Product. Without limiting the foregoing Purchaser assumes all risk and liability for loss, damage or injury to Purchaser and Purchaser's property and to others and their property arising out of the use, misuse, or inability to use this Product. This limited warranty shall not extend to anyone other than the original purchaser of this product, is nontransferable and states your exclusive remedy.

Some states do not allow the exclusion or limitation of incidental, consequential, special, or punitive damages, so the above limitation or exclusion may not apply to you. The above warranty gives you specific legal rights, and you may have other rights which vary from state to state.

CONTACT US

**QUESTIONS? NEED PARTS?
WE ARE HERE TO HELP!**

Please feel free to contact us. There are no questions too small, or any problems too big. We're committed to providing our customers with the highest level of service.

TRINITY Customer Service

TEL: 800.985.5506

FAX: 310.347.4134

EMAIL: customerservice@trinityii.com

**Monday through Friday
5:00 AM – 5:00 PM (PST)**

www.trinityii.com