

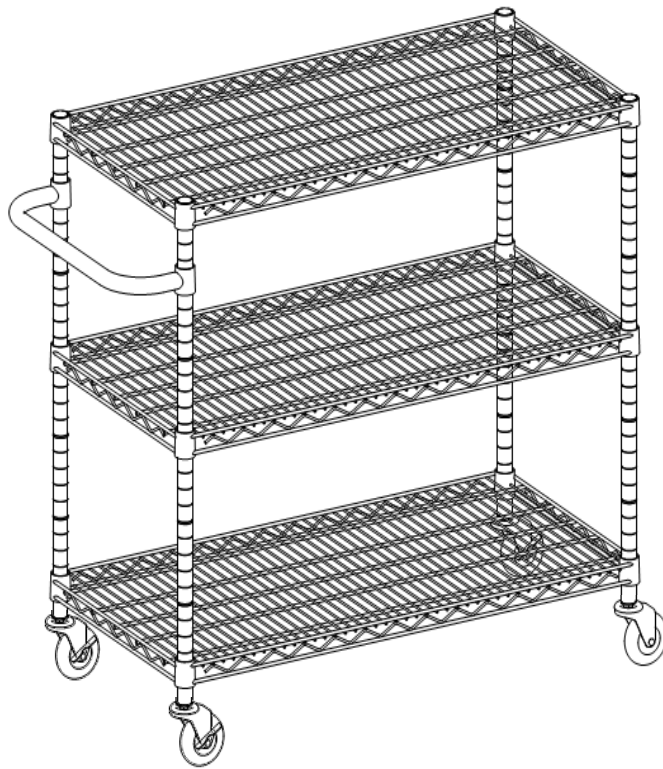

## OWNER'S MANUAL



### TRINITY ECOSTORAGE™ NSF 3-TIER CART Model # TBFZ-0902 / CTBFZ-0902



**Important / Important / Importante**

FOR QUICK & EASY 3D ASSEMBLY INSTRUCTIONS

POUR DES DIRECTIVES D'ASSEMBLAGE 3D RAPIDES ET FACILES

PARA INSTRUCCIONES DE ENSAMBLAJE RÁPIDAS Y SENCILLAS EN 3D

**BILT.**<sup>®</sup>

Intelligent Instructions  
Directives intelligentes  
Instrucciones Inteligentes





# PARTS LIST

Your TRINITY EcoStorage™ NSF 3-Tier Cart should include the following parts. Please inspect box contents to ensure you have received all components.

If you are missing any parts, need assistance with assembly or have questions, please contact TRINITY Customer Service: 800.985.5506 or [customerservice@trinityii.com](mailto:customerservice@trinityii.com). Parts can also be requested online via "Contact Us" section at [www.trinityii.com](http://www.trinityii.com).

You will NOT need additional tools for assembly.

A



4

B

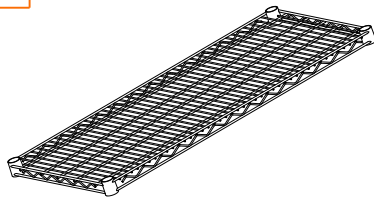

3

C



1

D



28 + 4

E



2

F



2

G



1



*Note: The black circular plastic spacers in between Shelves are used only for packaging purposes. They are NOT needed. Please discard.*

# ASSEMBLY INSTRUCTIONS

## STEP 1

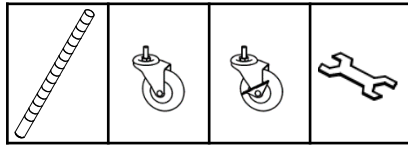

A (4)      E (2)      F (2)      G (1)

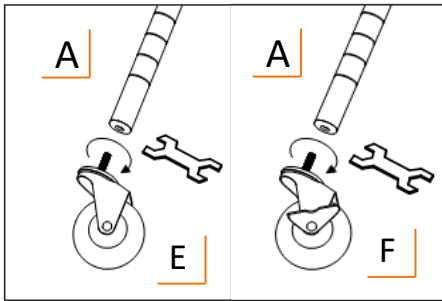

## STEP 2

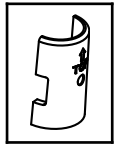

D (8)

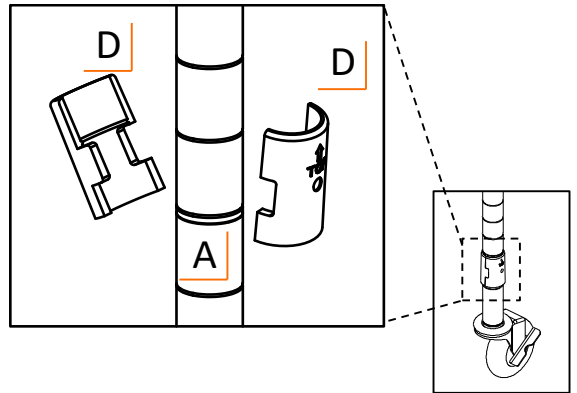

Warning: Tighten CASTERS (E & F) to POLES (A) completely. Failure to do as instructed could result in the caster stem breaking.

Note: For stability, the lowest SLIP SLEEVES (D) should be installed ***no higher*** than the 3rd indentation from the caster end of the POLES (A).

# ASSEMBLY INSTRUCTIONS

## STEP 3

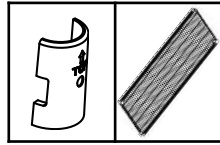

D (16) B (2)

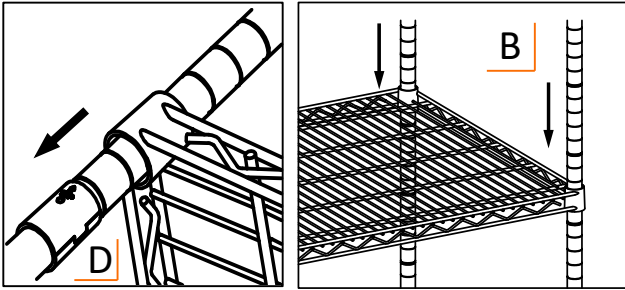

Note: The level side of the SHELF (B) is the TOP side (the TRINITY logo on the corner cylinders should be right-side up).

## STEP 4

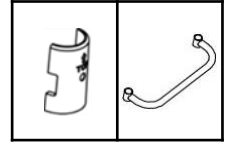

D (4) C (1)

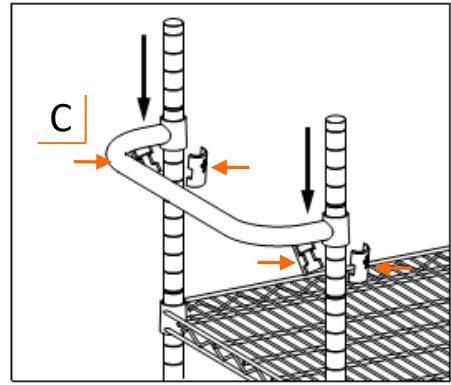

## STEP 5

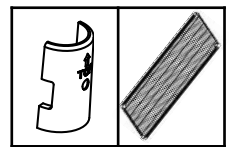

D (8) B (1)

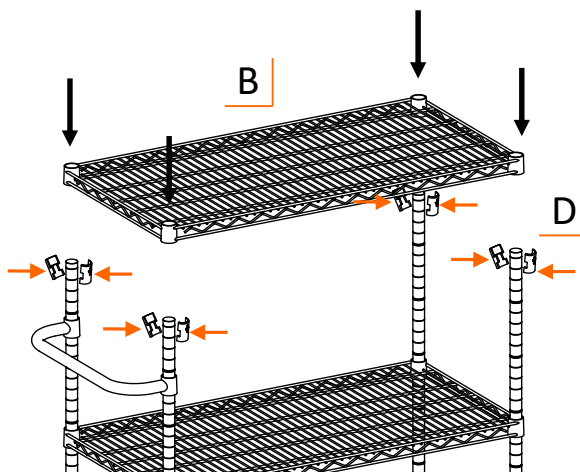

## SERVICE PARTS LIST – TBFZ-0902 / CTBFZ-0902 Chrome Color

TRINITY Customer Service provides the following replacement parts:

Part Number	Description	Part Number	Description
1) XBK-01-011-2543	Slip Sleeve	5) ZSV-99-008-4010	Locking Caster
2) ZSV-04-009-3100	Pole	6) ZSV-05-006-1800	Cart Handle
3) ZSV-99-007-4010	Non-locking Caster	7) XBK-23-004-2517	Endcap
4) XXX-97-002-0001	Wrench	8) ZSV-03-007-3618	Shelf

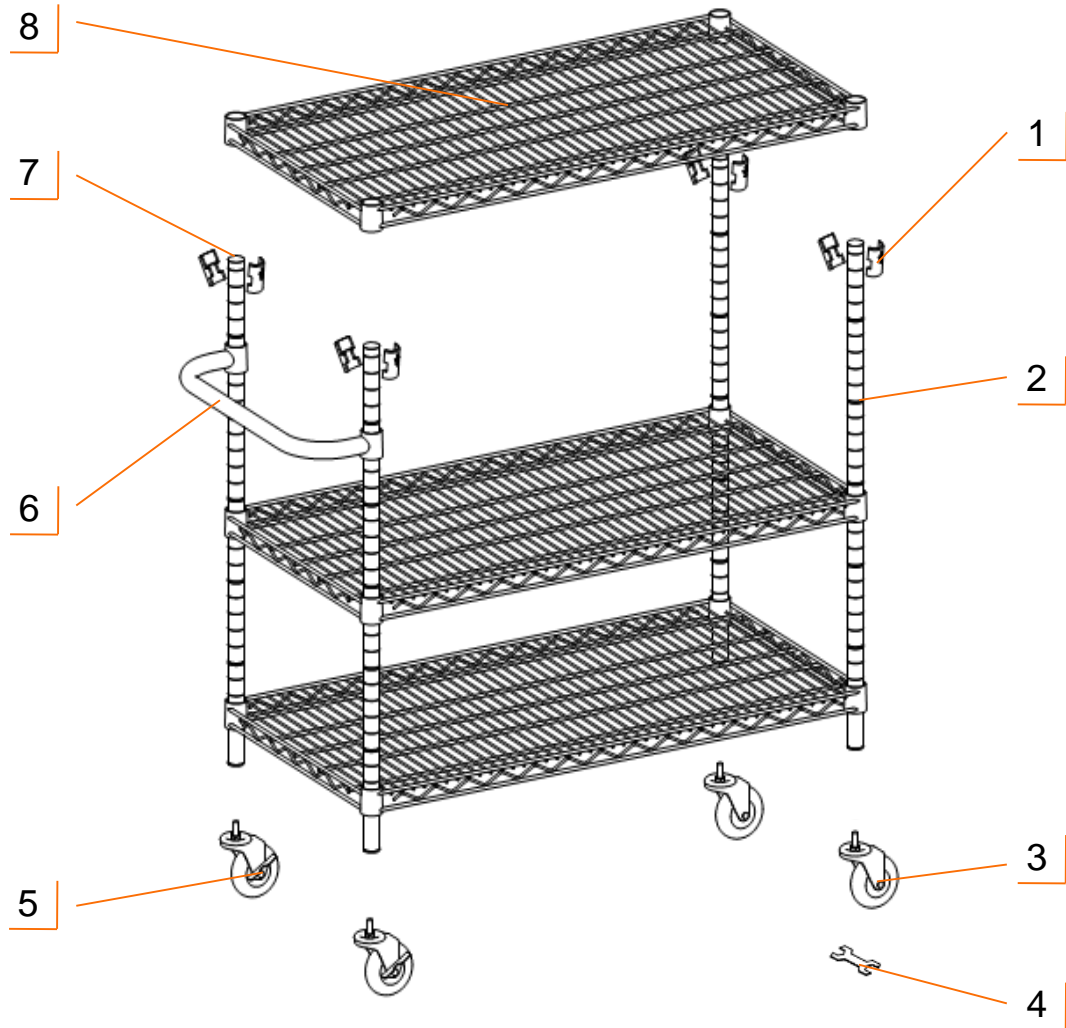

---

## WARNINGS

- 1. Read and understand all instructions.** Failure to follow all instructions may result in injury and / or damage.
- 2. Tighten all casters completely by using the wrench.** Failure to do as instructed could result in the caster stem breaking, thereby causing the product to collapse.
- 3. The warnings, cautions, and instructions discussed in this manual cannot cover all possible conditions or situations that may occur.** The user must always be aware of the environment and ensure to use the product in a safe and responsible manner.
- 4. Do NOT modify the product in any way.** Unauthorized modification may impair the function and / or safety of the product, and may affect the life of the product. Any modifications will void product warranty.
- 5. Check for damaged parts.** Before using this product, carefully check that all parts are in good condition, and that the product will operate properly and perform its intended function. Check for damaged parts and any other conditions that may affect the operation of this product. Replace damaged or worn parts, and never use this product with a damaged part.
- 6. Do NOT overload the product.**

Weight capacity per Shelf (evenly distributed)	<b>120.3 kg / 265 lb</b>
Total weight capacity of Cart (evenly distributed)	<b>363 kg / 800 lb</b>

- 7. Do NOT allow children to climb or play around the product.** Tipping may occur causing injury.
- 8. Do NOT roll the product on an uneven surface.** Only move the product on a smooth surface. Rolling over rough or uneven surface may cause casters to break or items on the product to fall, resulting in injury and / or damage.
- 9. Lock all locking casters when leaving the product in stationary position.**
- 10. Load the product evenly and place the heaviest items on the lower shelves.**

---

## CARE AND MAINTENANCE

- Avoid harsh, abrasive cleaners, and other corrosive chemicals.
- This product is not recommended for outdoor use.





# PRODUCT REGISTRATION

Thank you for purchasing a TRINITY EcoStorage™ NSF 3-Tier Cart. In order to register your product and receive streamlined customer service, please fill out the following Product Registration Form and (1) fax the form to 310.347.4134 (2) complete the Product Registration Form online at [www.trinityii.com](http://www.trinityii.com) or (3) scan and email the form to [customerservice@trinityii.com](mailto:customerservice@trinityii.com). Include a copy of your original receipt with your submission.

First Name: \_\_\_\_\_ Last Name: \_\_\_\_\_

Address: \_\_\_\_\_

City: \_\_\_\_\_ State: \_\_\_\_\_ Zip Code: \_\_\_\_\_

Email Address: \_\_\_\_\_ Phone: \_\_\_\_\_

Product Model #: TBFZ-0902 / CTBFZ-0902 Purchase Date: \_\_\_\_ / \_\_\_\_ / \_\_\_\_

Location of Purchase: \_\_\_\_\_

Please rate the importance of each feature (1=least important; 10=most important)

Quality \_\_\_\_ Price \_\_\_\_ Size/Capacity \_\_\_\_ Appearance \_\_\_\_ Other \_\_\_\_

How did you hear about our product?

- Magazine Ad     Catalog     Salesperson     Word of Mouth  
 Internet     Store Display     Other

Marital Status:                       Single                       Married

Household Income:                 Below \$50,000     \$50,000-\$150,000     \$150,000+

Education:                           High School     College     Graduate School

Primary Residence:                 Own                       Rent

Comments/Suggestions:





# 1 YEAR LIMITED WARRANTY

## TRINITY EcoStorage™ NSF 3-Tier Cart Model # TBFZ-0902 / CTBFZ-0902

Trinity International Industries (“Trinity”) warrants to the original consumer purchaser (“Purchaser”) of the TRINITY EcoStorage™ NSF 3-Tier Cart (“Product”) that each Product shall be free from defects in workmanship and materials for a period of 1 year from the date of original purchase. Trinity’s obligation under this warranty shall be limited to repair or replacement of, or adequate compensation for the Product which shall not be greater than the amount of the purchase price of the Product, at the option of Trinity, during the warranty period. All replaced parts and Products become the property of Trinity and must be returned to Trinity.

This warranty excludes normal wear and tear of the Product and its parts or components, and damage arising from any of the following: negligent use or misuse of the Product, use contrary to this User’s Manual, or alteration by any one other than Trinity. The warranty period of 1 year shall not be extended or renewed by the repair or replacement of, or compensation for, the Product. Any warranty implied by applicable law is limited in duration to one year from the date of purchase and is subject to the same conditions and limitations as is provided for our express warranty.

Except as set forth herein, and to the extent of applicable there are no warranties on this Product either express or implied, and Trinity disclaims all warranties including, but not limited to, any implied warranties of merchantability, infringement or fitness for a particular purpose. No warranty or guarantee given by any person, firm, or corporation with respect to this product shall be binding on Trinity.

If your Product is defective or otherwise requires service or parts, please call TRINITY Customer Service toll-free at (800) 985-5506, between 5:00 a.m. and 5:00 p.m., PST. Please tell us which model you purchased, the date of the purchase, and the problem with your Product. A copy of your original purchase receipt must accompany your service request.

## LIMITATION OF REMEDIES AND LIABILITY

Trinity (and its employees, officers, members, managers, affiliates and assigns) shall not be liable for any incidental, consequential, special, indirect, remote, special or punitive damages for breach of any warranty, express or implied, including, but not limited to, lost profits, lost savings, loss of anticipated benefits and attorneys’ fees, which arise out of the purchase, use or inability to use the Product, whether arising out of contract, negligence, strict tort, product liability, or any other legal theory on which a claim is based. As noted above, to the extent damages are allowed by our express warranty or by applicable law, those damages may not exceed the purchase price paid for the Product. Without limiting the foregoing Purchaser assumes all risk and liability for loss, damage or injury to Purchaser and Purchaser’s property and to others and their property arising out of the use, misuse, or inability to use this Product. This limited warranty shall not extend to anyone other than the original purchaser of this product, is nontransferable and states your exclusive remedy.

Some states do not allow the exclusion or limitation of incidental, consequential, special, or punitive damages, so the above limitation or exclusion may not apply to you. The above warranty gives you specific legal rights, and you may have other rights which vary from state to state.

---

## CONTACT US

**QUESTIONS? NEED PARTS?  
WE ARE HERE TO HELP!**

**Please feel free to contact us. There are no questions too small, or any problems too big. We're committed to providing our customers with the highest level of service.**

### **TRINITY Customer Service**

**TEL: 800.985.5506**

**FAX: 310.347.4134**

**EMAIL: [customerservice@trinityii.com](mailto:customerservice@trinityii.com)**

**Monday through Friday  
5:00 AM – 5:00 PM (PST)**

**[www.trinityii.com](http://www.trinityii.com)**