

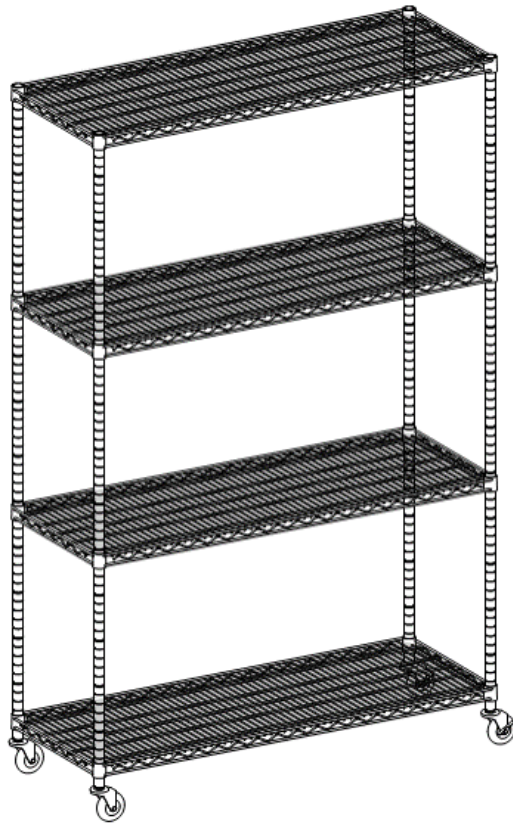

OWNER'S MANUAL



**TRINITY 4-TIER NSF 48" x 18" x 72"
WIRE SHELVING RACK w/WHEELS and LINERS – BLACK
Model # TBFPB-0907**



Important / Important / Importante

FOR QUICK & EASY 3D ASSEMBLY INSTRUCTIONS
POUR DES DIRECTIVES D'ASSEMBLAGE 3D RAPIDES ET FACILES
PARA INSTRUCCIONES DE ENSAMBLAJE RÁPIDAS Y SENCILLAS EN 3D

BILT.[®]

Intelligent Instructions
Directives intelligentes
Instrucciones Inteligentes



DOWNLOAD THE FREE APP | TÉLÉCHARGER L'APPLICATION GRATUITE | DESCARGUE LA APLICACIÓN GRATUITA

PARTS LIST

Your TRINITY 4-Tier NSF Wire Shelving Rack w/Wheels and Liners – Black should include the following parts. Please inspect box contents to ensure you have received all components.

If you are missing any parts, need assistance with assembly or have questions, please contact TRINITY Customer Service: 800.985.5506 or customerservice@trinityii.com. Parts can also be requested online via “Contact Us” section at www.trinityii.com.

You will NOT need additional tools for assembly.



BOTTOM POLE (4)
Threaded Insert (4)
is pre-installed



TOP POLE (4)
End Cap (4) and
Pole Connector (4)
are pre-installed

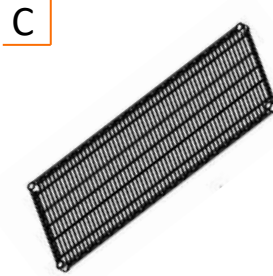

SHELF (4)

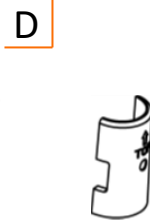

SLIP SLEEVE
(32) + (2) extra

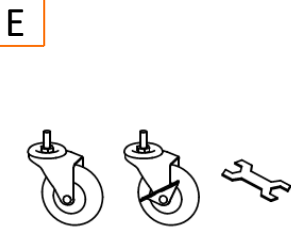

CASTER (w/wrench)
(2 locking, 2 non-locking)
For mobile option



FEET LEVELER (4)
For stationary option

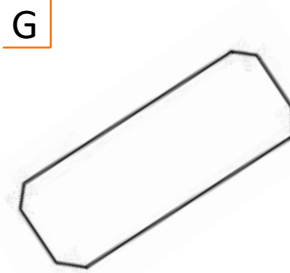

SHELF LINER (4)



Note: The black circular plastic spacers in between Shelves are used only for packaging purposes. They are NOT needed. Please discard.

ASSEMBLY INSTRUCTIONS

STEP 1: Stationary Option

Screw each FEET LEVELER (F) into the bottom of each BOTTOM POLE (A). Turn clockwise to screw in place.

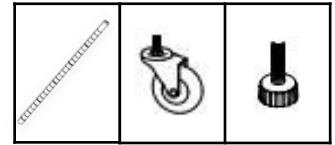

A (4) E (4) F (4)

STEP 1: Mobile Option

Screw each CASTER (E) into the bottom of each BOTTOM POLE (A). Turn clockwise to screw in place. Make sure the Locking Casters are on the same side.

Use the provided caster wrench to tighten completely. Failure to do as instructed could result in the caster stem breaking.

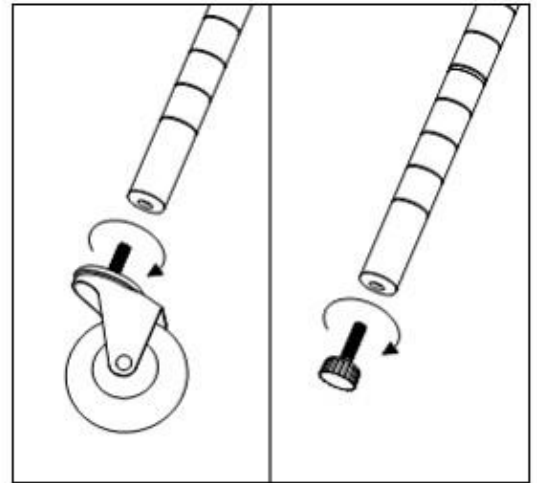

STEP 2: SLIP SLEEVES

For easiest assembly, do not attach the TOP (B) and BOTTOM (A) POLES until instructed. Once connected, these will be the posts for the Rack.

Note that each POLE (A+B) has slight horizontal line indentations at 1" intervals. Each SLIP SLEEVE (D) has raised horizontal lines inside designed to lock them in place on the POLE (A+B).

On the BOTTOM POLE (A), place 1 pair of SLIP SLEEVES (D) at the desired level. Please make sure the arrow faces up and that the word "TOP" is right side up. Do this for each BOTTOM POLE (A) and make sure that the heights are identical for BOTTOM POLE (A).

Slide the pair of SLIP SLEEVES (D) until you hear a click to confirm the pair is locked onto the BOTTOM POLE (A). DO NOT place more than one pair on each POLE (A) at a time.

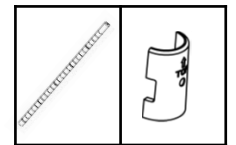

A (4) D (8)

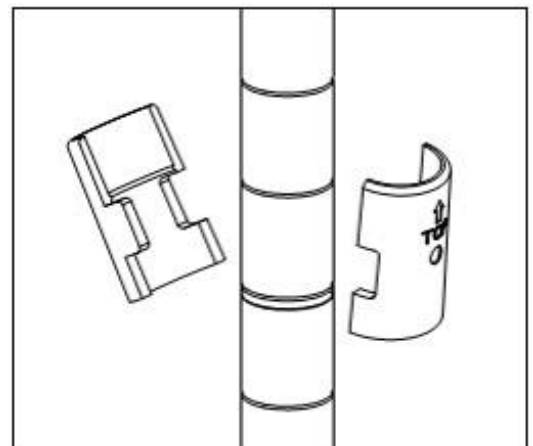

* For safety and stability, the lowest SHELF (C) should be lower than the 3rd notch from the bottom.

** Note: There will be a very small gap in-between the SLIP SLEEVES (D)—this is normal.

ASSEMBLY INSTRUCTIONS

STEP 3: INSTALLING BOTTOM SHELF

Place SHELF (C) on its side and slide the (4) BOTTOM POLES (A) through the holes in the SHELF (C). Make sure that the SHELF (C) corner cylinders are positioned over the SLIP SLEEVES (D).

Stand the unit upright.

**Note: The level side of the SHELF (C) is the TOP side (the TRINITY logo on the corner cylinders should be right-side up.)*

***Use a rubber mallet, if needed, to secure the SHELF (C).*

****For convenience, place BOTTOM POLES (A) with Locking Casters on the long side of the shelf if the rack will be pushed against a wall OR if the rack is frequently rolled around like a cart place BOTTOM POLES (A) with Locking Casters on the side being pushed or pulled.*

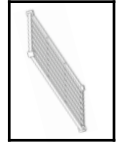

C (1)

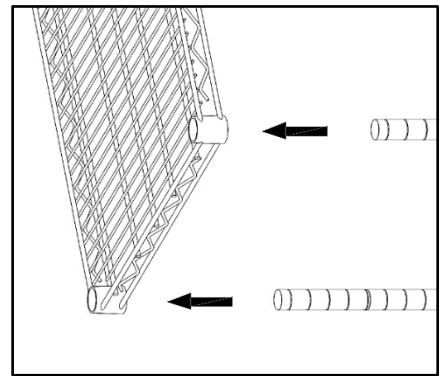

STEP 4: INSTALLING SHELVES

On POLE (A), place 1 pair of SLIP SLEEVES (E) at the desired distance between SHELVES (C). Please make sure the arrow faces up and that the word "TOP" is right side up. Do this for each POLE (A), and make sure that the heights are identical for each POLE (A).

Lower SHELF (C) over the BOTTOM POLES (A) so that the corner cylinders of the SHELF (C) are positioned over the SLIP SLEEVES (D).

Repeat Step 4 to install other SHELVES (C) as desired.

***Use a rubber mallet, if needed, to secure the SHELVES (C).*

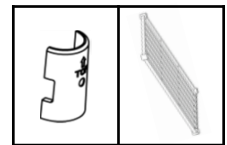

D (8)

C (1)

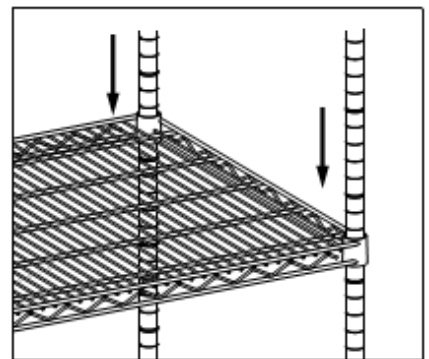

ASSEMBLY INSTRUCTIONS

STEP 5: INSTALLING TOP POLES

Screw the TOP POLE (B) into the BOTTOM POLE (A). The tops of these poles are indicated by the BLACK END CAP.



B (4)

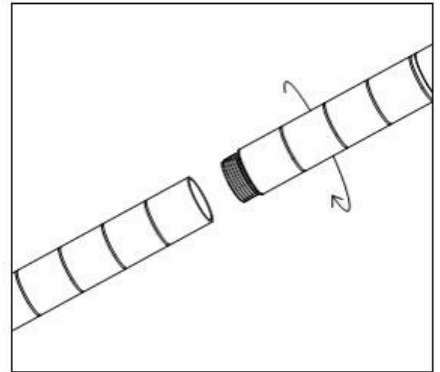

STEP 6: INSTALLING SHELVES

On POLE (A+B), place 1 pair of SLIP SLEEVES (D) at the desired distance between SHELVES (C). Please make sure the arrow faces up and that the word "TOP" is right side up. Do this for each POLE (A+B), and make sure that the heights are identical for each POLE (A+B).

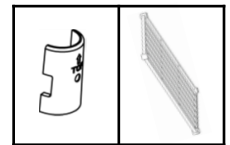

D (16)

C (2)

Lower SHELF (C) over the TOP POLES (B) so that the corner cylinders of the SHELF (C) are positioned over the SLIP SLEEVES (D).

Repeat Step 6 to install other SHELVES (C) as desired.

***Use a rubber mallet, if needed, to secure the SHELVES (C).*

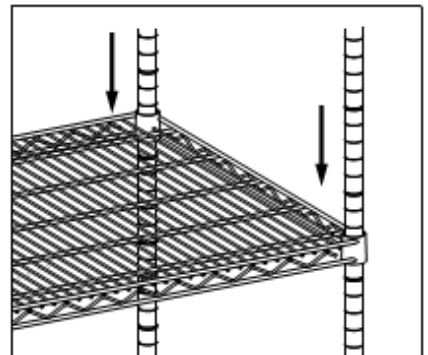

ASSEMBLY INSTRUCTIONS

STEP 7: INSTALLING SHELF LINERS

Your shelving rack comes with 4 SHELF LINERS (G) to prevent items from falling in between the wires. Lay them across each shelf as the corners are specially cut to fit your shelving unit. Liners can easily be cleaned and wiped down as necessary.

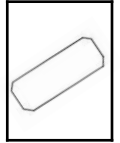

G (4)

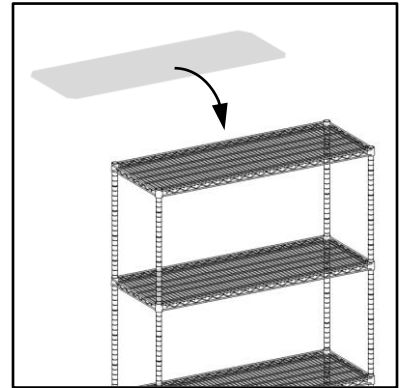

SERVICE PARTS LIST – TBFPB-0907 Black Color

TRINITY Customer Service provides the following replacement parts:

Part Number	Description	Part Number	Description
1) XBK-01-012-2543	Slip Sleeve	7) ZSV-99-007-4010	Non-locking Caster
2) PBK-04-006-3600	Top Pole	8) XXX-97-002-0001	Wrench
3) ZSV-01-013-2523	Pole Connector	9) TBF-LINERS01-4818	Liner
4) PBK-04-008-3600	Bottom Pole	10) XBK-23-004-2517	Endcap
5) ZSV-99-008-4010	Locking Caster	11) PBK-03-007-4818	Shelf
6) XBK-98-003-2538	Feet Leveler		

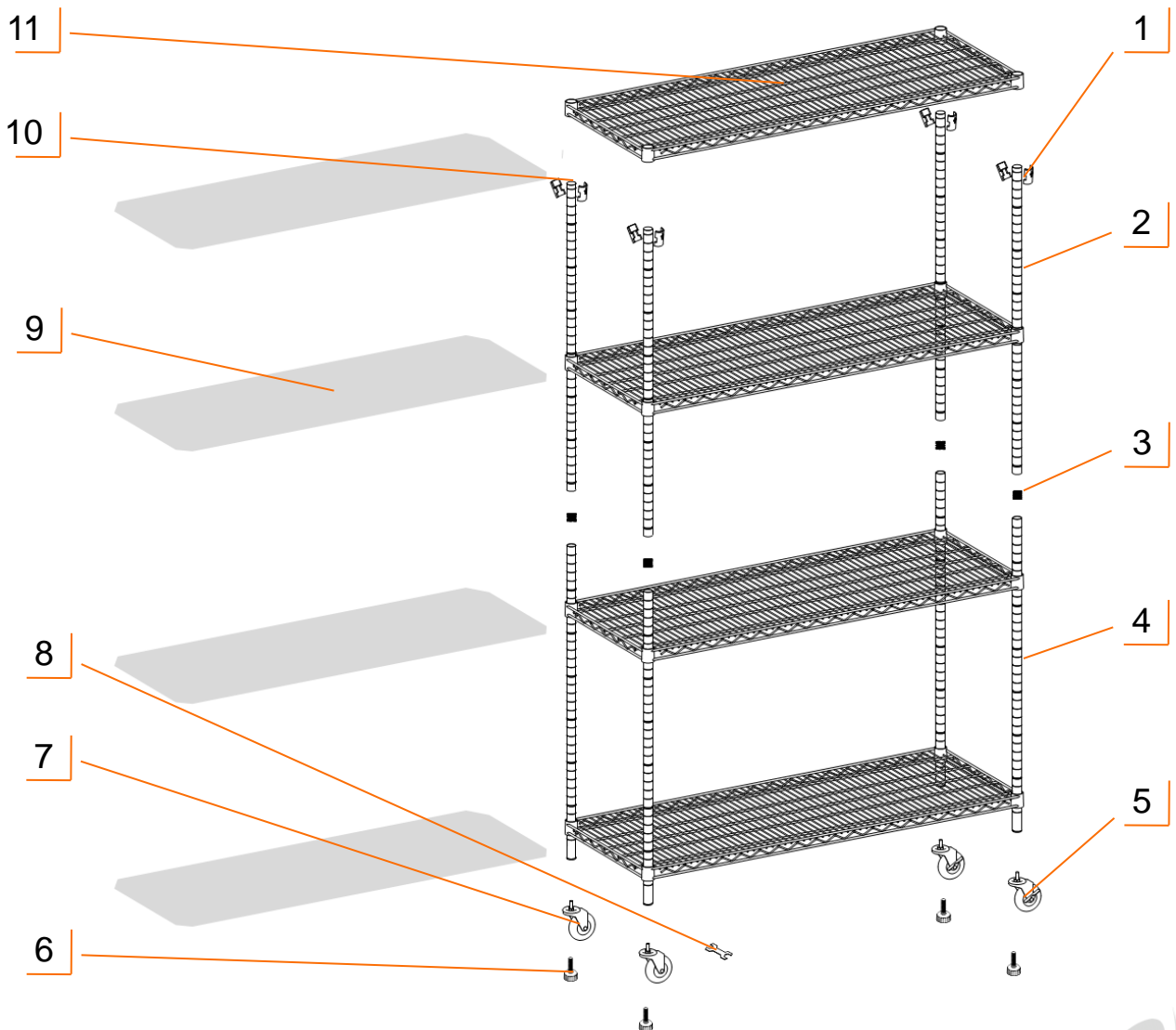

WARNINGS

1. **Read and understand all instructions.** Failure to follow all instructions may result in injury and/or damage.
2. **Use the provided caster wrench to tighten casters completely.** Failure to do as instructed could result in the caster stem breaking thereby causing the shelving rack to collapse.
3. **The warnings, cautions, and instructions discussed in this manual cannot cover all possible conditions or situations that may occur.** The user must always be aware of the environment where the product will be placed and make sure to use the product in a safe and responsible manner.
4. **Do NOT modify the product in any way.** Unauthorized modification may impair the function and/or safety of the product, and may affect the life of the product. Any modifications will void product warranty.
5. **Check for damaged parts.** Before using this product, carefully check that all parts are in good condition, and that the product will operate properly and perform its intended function. Check for damaged parts and any other conditions that may affect the operation of this product. Replace damaged or worn parts, and never use this product with a damaged part.
6. **Do NOT overload the product.**

Weight capacity per Shelf on Feet Levelers	800 lb (evenly distributed)
Weight capacity per Shelf on Casters	200 lb (evenly distributed)
Total weight capacity of Shelving Rack (evenly distributed)	3200 lb (on Feet Levelers) 800 lb (on Casters)

7. **Do NOT allow children to climb or play around the product.** Tipping may occur causing injury.
8. **Do NOT roll the product on an uneven surface.** Only move the product on a smooth surface. Rolling over rough or uneven surface may cause casters to break or items on the product to fall, resulting in injury and / or damage.
9. **Load the product evenly and place the heaviest items on the lower shelves.**

CARE AND MAINTENANCE

- Avoid harsh, abrasive cleaners, and other corrosive chemicals.
- This product is not recommended for outdoor use.





1 YEAR LIMITED WARRANTY

TRINITY 4-Tier NSF Wire Shelving Rack w/Wheels and Liners - Black Model # TBFPB-0907

Trinity International Industries (“Trinity”) warrants to the original consumer purchaser (“Purchaser”) of the TRINITY 4-Tier NSF Wire Shelving Rack w/Wheels and Liners – Black (“Product”) that each Product shall be free from defects in workmanship and materials for a period of 1 year from the date of original purchase. Trinity’s obligation under this warranty shall be limited to repair or replacement of, or adequate compensation for the Product which shall not be greater than the amount of the purchase price of the Product, at the option of Trinity, during the warranty period. All replaced parts and Products become the property of Trinity and must be returned to Trinity.

This warranty excludes normal wear and tear of the Product and its parts or components, and damage arising from any of the following: negligent use or misuse of the Product, use contrary to this User’s Manual, or alteration by any one other than Trinity. The warranty period of 1 year shall not be extended or renewed by the repair or replacement of, or compensation for, the Product. Any warranty implied by applicable law is limited in duration to one year from the date of purchase and is subject to the same conditions and limitations as is provided for our express warranty.

Except as set forth herein, and to the extent of applicable there are no warranties on this Product either express or implied, and Trinity disclaims all warranties including, but not limited to, any implied warranties of merchantability, infringement or fitness for a particular purpose. No warranty or guarantee given by any person, firm, or corporation with respect to this product shall be binding on Trinity.

If your Product is defective or otherwise requires service or parts, please call TRINITY Customer Service toll-free at (800) 985-5506, between 5:00 a.m. and 5:00 p.m., PST. Please tell us which model you purchased, the date of the purchase, and the problem with your Product. A copy of your original purchase receipt must accompany your service request.

LIMITATION OF REMEDIES AND LIABILITY

Trinity (and its employees, officers, members, managers, affiliates and assigns) shall not be liable for any incidental, consequential, special, indirect, remote, special or punitive damages for breach of any warranty, express or implied, including, but not limited to, lost profits, lost savings, loss of anticipated benefits and attorneys’ fees, which arise out of the purchase, use or inability to use the Product, whether arising out of contract, negligence, strict tort, product liability, or any other legal theory on which a claim is based. As noted above, to the extent damages are allowed by our express warranty or by applicable law, those damages may not exceed the purchase price paid for the Product. Without limiting the foregoing Purchaser assumes all risk and liability for loss, damage or injury to Purchaser and Purchaser’s property and to others and their property arising out of the use, misuse, or inability to use this Product. This limited warranty shall not extend to anyone other than the original purchaser of this product, is nontransferable and states your exclusive remedy.

Some states do not allow the exclusion or limitation of incidental, consequential, special, or punitive damages, so the above limitation or exclusion may not apply to you. The above warranty gives you specific legal rights, and you may have other rights which vary from state to state.

CONTACT US

**QUESTIONS? NEED PARTS?
WE ARE HERE TO HELP!**

Please feel free to contact us. There are no questions too small, or any problems too big. We're committed to providing our customers with the highest level of service.

TRINITY Customer Service

TEL: 800.985.5506

FAX: 310.347.4134

EMAIL: customerservice@trinityii.com

**Monday through Friday
5:00 AM – 5:00 PM (PST)**

www.trinityii.com