

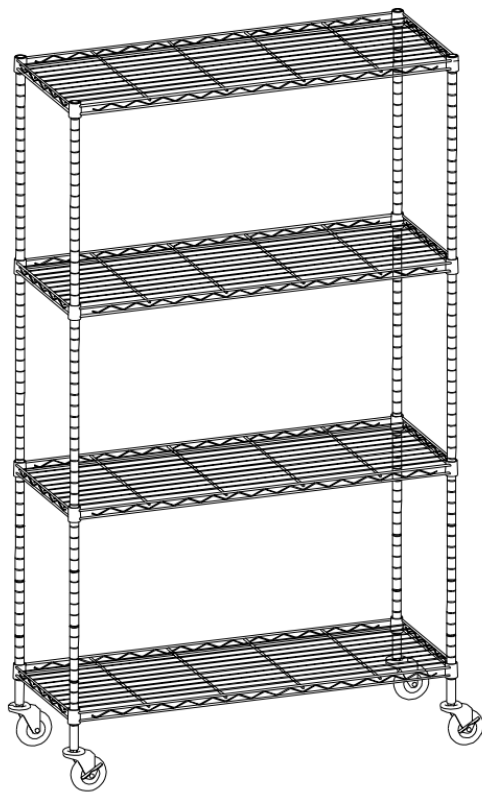

## OWNER'S MANUAL



**TRINITY BASICS ECOSTORAGE 4-TIER NSF 36" x 14" x 62.5"  
WIRE SHELVING RACK w/WHEELS – BLACK  
Model # TBFPB-0934**



**Important / Important / Importante**

FOR QUICK & EASY 3D ASSEMBLY INSTRUCTIONS

POUR DES DIRECTIVES D'ASSEMBLAGE 3D RAPIDES ET FACILES

PARA INSTRUCCIONES DE ENSAMBLAJE RÁPIDAS Y SENCILLAS EN 3D

**BILT.**<sup>®</sup>

Intelligent Instructions  
Directives intelligentes  
Instrucciones Inteligentes



DOWNLOAD THE FREE APP | TÉLÉCHARGER L'APPLICATION GRATUITE | DESCARGUE LA APLICACIÓN GRATUITA

# PARTS LIST

Your TRINITY Basics 4-TIER NSF Black Wire Shelving Rack with Wheels should include the following parts. Please inspect box contents to ensure you have received all components.

If you are missing any parts, need assistance with assembly or have questions, please contact TRINITY Customer Service: 800.985.5506 or [customerservice@trinityii.com](mailto:customerservice@trinityii.com). Parts can also be requested online via "Contact Us" section at [www.trinityii.com](http://www.trinityii.com).

You will NOT need additional tools for assembly.

A

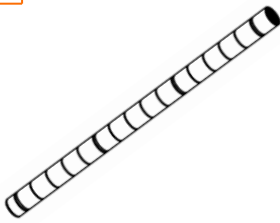

**TOP POLE (4)**  
End Cap (4) and  
Pole Connector (4)  
pre-installed

B

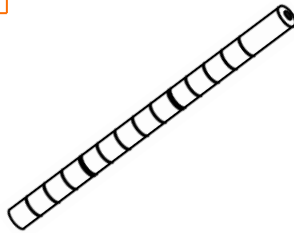

**BOTTOM POLE (4)**  
Threaded Insert (4)  
pre-installed

C

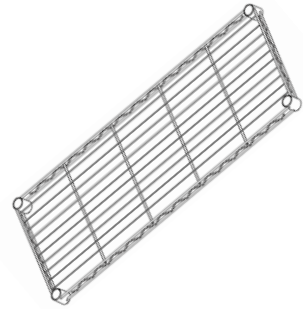

**SHELF (4)**

D



**SLIP SLEEVE**  
(32) + (2) extra

E

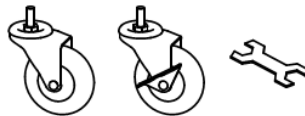

**CASTER (w/wrench)**  
(2 locking, 2 non-locking)  
For mobile option

F



**FEET LEVELER (4)**  
For stationary option



*Note: The black circular plastic spacers in between Shelves are used only for packaging purposes. They are NOT needed. Please discard.*

# ASSEMBLY INSTRUCTIONS

## STEP 1

### Stationary Option

Screw each FEET LEVELER (F) into bottom of each BOTTOM POLE (B). Turn clockwise to screw in place.

**Warning: For safety, at least half of FEET LEVELER (F) stem must be screwed into BOTTOM POLE (B).**

### Mobile Option

Screw each CASTER (E) into bottom of each BOTTOM POLE (B). Turn clockwise to screw in place. Make sure the locking casters are on the same side.

**Use the provided caster wrench to tighten completely. Failure to do as instructed could result in the caster stem breaking.**

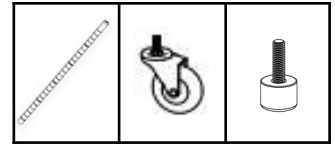

B (4)

E (4)

F (4)

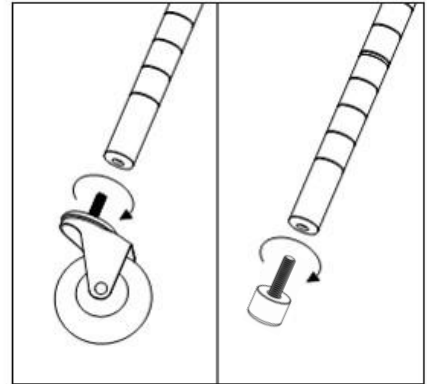

## STEP 2

For easiest assembly, do not attach TOP (A) and BOTTOM (B) POLES until instructed. Once connected, these will be the posts for the rack.

Note that each POLE (A+B) has slight horizontal line indentations at 1" intervals. Each SLIP SLEEVE (D) has raised horizontal lines inside designed to lock them in place on POLE (A+B).

On BOTTOM POLE (B), place 1 pair of SLIP SLEEVES (D) at the desired level no higher than the 3<sup>rd</sup> indentation from the bottom. Please make sure the arrow faces up and that the word "TOP" is right side up. Do this for each BOTTOM POLE (B) and make sure that the heights are identical for BOTTOM POLE (B).

Slide the pair of SLIP SLEEVES (D) until you hear a click to confirm the pair is locked onto BOTTOM POLE (B). DO NOT place more than one pair on each POLE (B) at a time.

*Note: There will be a very small gap in-between two locked SLIP SLEEVES (D)—this is normal.*

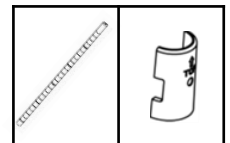

B (4)

D (8)

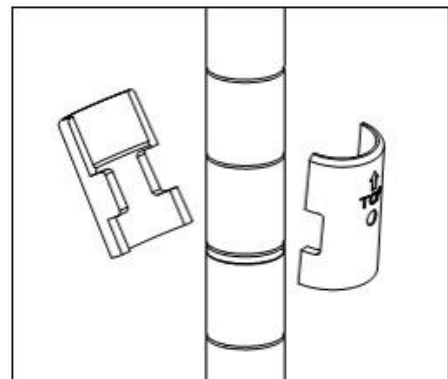

# ASSEMBLY INSTRUCTIONS

## STEP 3

Place SHELF (C) on its side and slide (4) BOTTOM POLES (B) through the holes in SHELF (C). Make sure that SHELF (C) corner cylinders are positioned over SLIP SLEEVES (D).

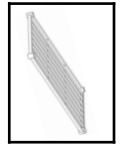

C (1)

Stand the unit upright.

### Note:

- The level side of SHELF (C) is the TOP side (the TRINITY logo on the corner cylinders should be right-side up.)
- Use a rubber mallet, if needed, to secure SHELF (C).
- For convenience, place BOTTOM POLES (B) with Locking Casters on the long side of the shelf if the rack will be pushed against a wall OR if the rack is frequently rolled around like a cart place BOTTOM POLES (B) with Locking Casters on the side being pushed or pulled.

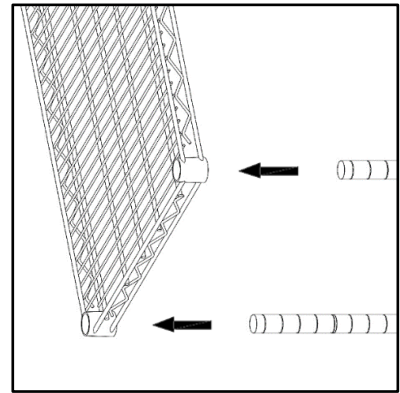

## STEP 4

On BOTTOM POLE (B), place 1 pair of SLIP SLEEVES (D) at the desired height between SHELVES (C). Please make sure the arrow faces up and that the word "TOP" is right side up. Do this for each BOTTOM POLE (B), and make sure that the heights are identical for each BOTTOM POLE (B).

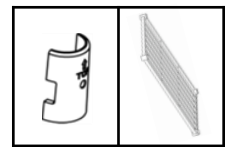

D (8)

C (1)

Lower SHELF (C) over BOTTOM POLES (B) so that the corner cylinders of SHELF (C) are positioned over SLIP SLEEVES (D).

Repeat Step 4 to install other SHELVES (C) as desired.

Note: Use a rubber mallet, if needed, to secure SHELVES (C).

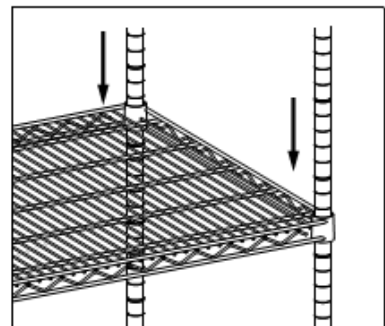

# ASSEMBLY INSTRUCTIONS

## STEP 5

Screw TOP POLE (A) into BOTTOM POLE (B).

The tops of these poles are indicated by the BLACK END CAP.

Repeat for remaining 3 TOP POLES (A).



A (4)

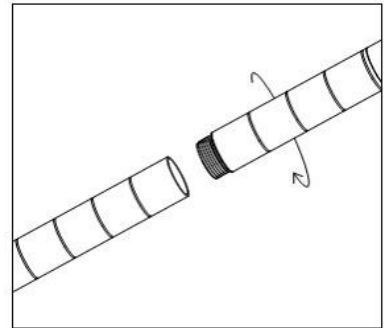

## STEP 6

On POLE (A+B), place 1 pair of SLIP SLEEVES (D) at the desired height between SHELVES (C). Please make sure the arrow faces up and that the word "TOP" is right side up. Do this for each POLE (A+B), and make sure that the heights are identical for each POLE (A+B).

Lower SHELF (C) over TOP POLES (A) so that the corner cylinders of SHELF (C) are positioned over SLIP SLEEVES (D).

Repeat Step 6 to install other SHELVES (C) as desired.

*Note: Use a rubber mallet, if needed, to secure SHELVES (C).*

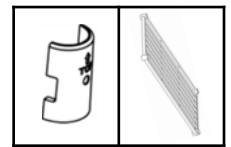

D (16)

C (4)

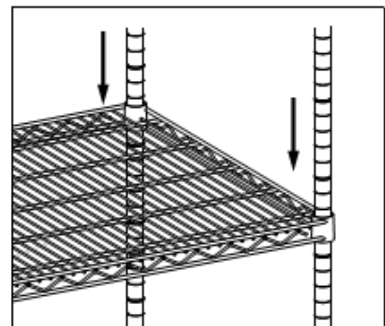

## SERVICE PARTS LIST – TBFPB-0934 Black Color

TRINITY Customer Service provides the following replacement parts:

Part Number	Description	Part Number	Description
1) XBK-01-012-1936	Slip Sleeve	6) XBK-98-003-1938	Feet Leveler
2) PBK-04-013-2950	Top Pole	7) ZSV-99-007-3010	Non-locking Caster
3) ZSV-01-013-1923	Pole Connector	8) XXX-97-002-0001	Wrench
4) PBK-04-015-2925	Bottom Pole	9) PBK-03-014-3614	Shelf
5) ZSV-99-008-3010	Locking Caster	10) XBK-23-004-1911	End Cap

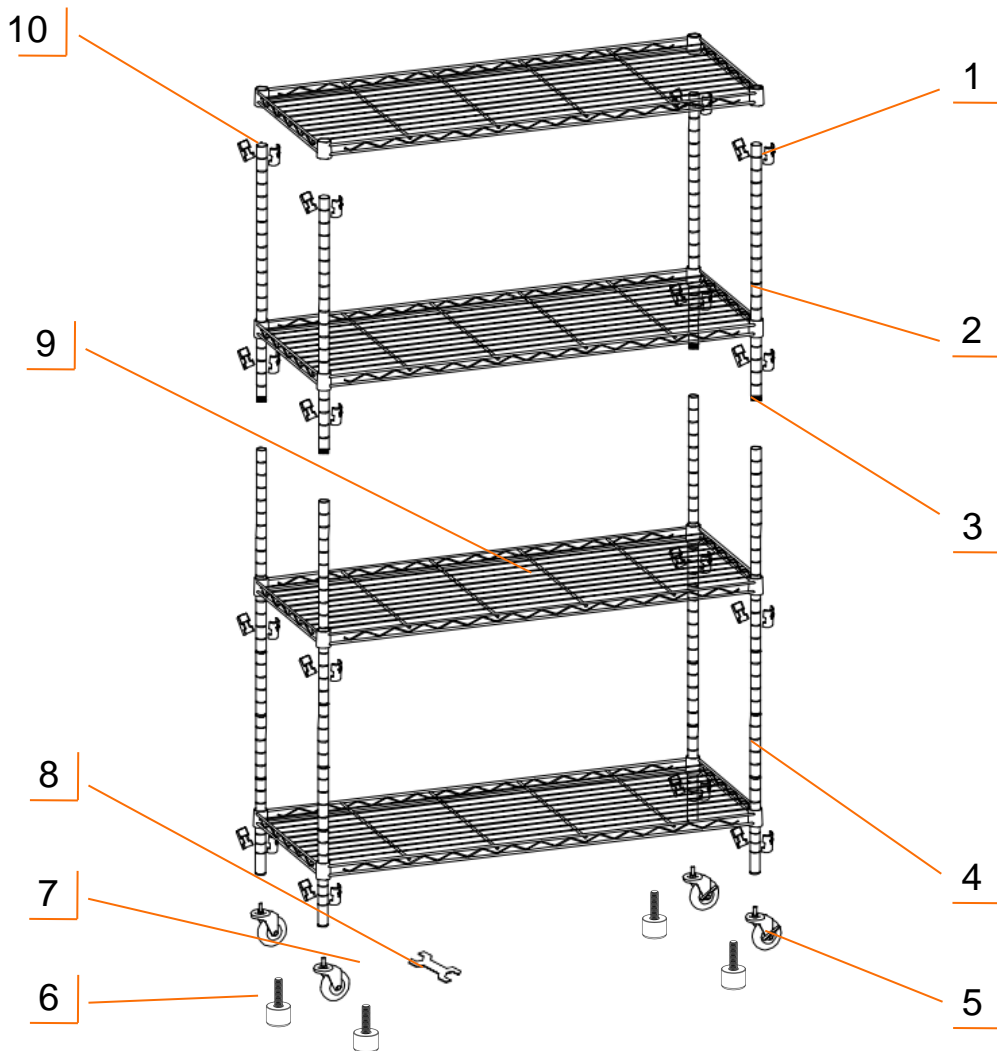

---

## WARNINGS

1. **Read and understand all instructions.** Failure to follow all instructions may result in injury and/or damage.
2. **Use the provided caster wrench to tighten casters completely.** Failure to do as instructed could result in the caster stem breaking thereby causing the shelving rack to collapse.
3. **The warnings, cautions, and instructions discussed in this manual cannot cover all possible conditions or situations that may occur.** The user must always be aware of the environment where the product will be placed and make sure to use the product in a safe and responsible manner.
4. **Do NOT modify the product in any way.** Unauthorized modification may impair the function and/or safety of the product, and may affect the life of the product. Any modifications will void product warranty.
5. **Check for damaged parts.** Before using this product, carefully check that all parts are in good condition, and that the product will operate properly and perform its intended function. Check for damaged parts and any other conditions that may affect the operation of this product. Replace damaged or worn parts, and never use this product with a damaged part.
6. **Do NOT overload the product.**

Weight capacity per Shelf on Feet Levelers	<b>250 lb (evenly distributed)</b>
Weight capacity per Shelf on Casters	<b>150 lb (evenly distributed)</b>
Total weight capacity of Shelving Rack (evenly distributed)	<b>1000 lb (on Feet Levelers) 600 lb (on Casters)</b>

7. **Do NOT allow children to climb or play around the product.** Tipping may occur causing injury.
8. **Do NOT roll the product on an uneven surface.** Only move the product on a smooth surface. Rolling over rough or uneven surface may cause casters to break or items on the product to fall, resulting in injury and / or damage.
9. **Load the unit evenly and place the heaviest items on the lower shelves.**

---

## CARE AND MAINTENANCE

- Wipe with a dry cloth as needed to remove dust and dirt.
- Avoid harsh, abrasive cleaners, and other corrosive chemicals.
- This item is not certified for outdoor use.









# 1 YEAR LIMITED WARRANTY

## TRINITY Basics 4-Tier NSF Wire Shelving Rack w/Wheels Model # TBFPB-0934

Trinity International Industries (“Trinity”) warrants to the original consumer purchaser (“Purchaser”) of the TRINITY Basics 4-Tier NSF Black Wire Shelving Rack w/Wheels (“Product”) that each Product shall be free from defects in workmanship and materials for a period of 1 year from the date of original purchase. Trinity’s obligation under this warranty shall be limited to repair or replacement of, or adequate compensation for the Product which shall not be greater than the amount of the purchase price of the Product, at the option of Trinity, during the warranty period. All replaced parts and Products become the property of Trinity and must be returned to Trinity.

This warranty excludes normal wear and tear of the Product and its parts or components, and damage arising from any of the following: negligent use or misuse of the Product, use contrary to this User’s Manual, or alteration by any one other than Trinity. The warranty period of 1 year shall not be extended or renewed by the repair or replacement of, or compensation for, the Product. Any warranty implied by applicable law is limited in duration to one year from the date of purchase and is subject to the same conditions and limitations as is provided for our express warranty.

Except as set forth herein, and to the extent of applicable there are no warranties on this Product either express or implied, and Trinity disclaims all warranties including, but not limited to, any implied warranties of merchantability, infringement or fitness for a particular purpose. No warranty or guarantee given by any person, firm, or corporation with respect to this product shall be binding on Trinity.

If your Product is defective or otherwise requires service or parts, please call TRINITY Customer Service toll-free at (800) 985-5506, between 5:00 a.m. and 5:00 p.m., PST. Please tell us which model you purchased, the date of the purchase, and the problem with your Product. A copy of your original purchase receipt must accompany your service request.

### LIMITATION OF REMEDIES AND LIABILITY

Trinity (and its employees, officers, members, managers, affiliates and assigns) shall not be liable for any incidental, consequential, special, indirect, remote, special or punitive damages for breach of any warranty, express or implied, including, but not limited to, lost profits, lost savings, loss of anticipated benefits and attorneys’ fees, which arise out of the purchase, use or inability to use the Product, whether arising out of contract, negligence, strict tort, product liability, or any other legal theory on which a claim is based. As noted above, to the extent damages are allowed by our express warranty or by applicable law, those damages may not exceed the purchase price paid for the Product. Without limiting the foregoing Purchaser assumes all risk and liability for loss, damage or injury to Purchaser and Purchaser’s property and to others and their property arising out of the use, misuse, or inability to use this Product. This limited warranty shall not extend to anyone other than the original purchaser of this product, is nontransferable and states your exclusive remedy.

Some states do not allow the exclusion or limitation of incidental, consequential, special, or punitive damages, so the above limitation or exclusion may not apply to you. The above warranty gives you specific legal rights, and you may have other rights which vary from state to state.

---

## CONTACT US

**QUESTIONS? NEED PARTS?  
WE ARE HERE TO HELP!**

**Please feel free to contact us. There are no questions too small, or any problems too big. We're committed to providing our customers with the highest level of service.**

### **TRINITY Customer Service**

**TEL: 800.985.5506**

**FAX: 310.347.4134**

**EMAIL: [customerservice@trinityii.com](mailto:customerservice@trinityii.com)**

**Monday through Friday  
5:00 AM – 5:00 PM (PST)**

**[www.trinityii.com](http://www.trinityii.com)**