

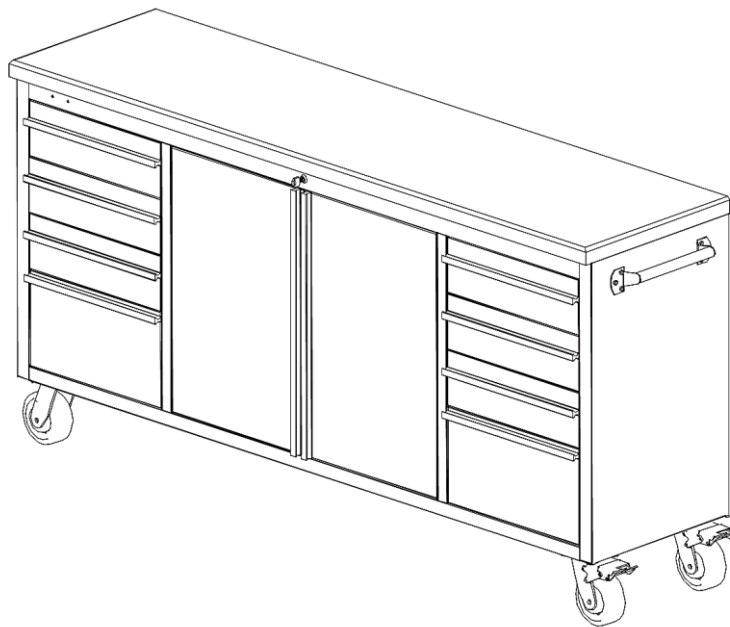

OWNER'S MANUAL



TRINITY 72" ROLLING WORKBENCH – STAINLESS STEEL Model # TLS-7204 (Stainless Body) TLS-7205 (Black Body)



Important / Important / Importante



FOR QUICK & EASY 3D ASSEMBLY INSTRUCTIONS
POUR DES DIRECTIVES D'ASSEMBLAGE 3D RAPIDES ET FACILES
PARA INSTRUCCIONES DE ENSAMBLAJE RAPIDAS Y SENCILLAS EN 3D

BILT.[®]

Intelligent Instructions
Directives intelligentes
Instrucciones Inteligentes



DOWNLOAD THE FREE APP | TÉLÉCHARGER L'APPLICATION GRATUITE | DESCARGUE LA APLICACIÓN GRATUITA

PARTS LIST

Your TRINITY 72" Rolling Workbench should include the following parts. Please inspect box contents to ensure you have received all components.

If you are missing any parts, need assistance with assembly or have questions, please contact TRINITY Customer Service: 800.985.5506 or customerservice@trinityii.com. Parts can also be requested online via our "Contact Us" section at www.trinityii.com.

You will need 10mm wrench (for handles) and 14mm socket wrench (for casters) for assembly.

A

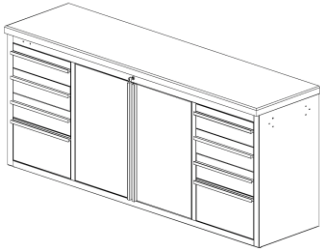

WORKBENCH (1)

B

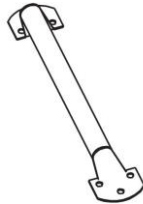

SIDE HANDLE (2)

C



**HANDLE BOLT (12)
M6**

D



LOCKING CASTER (2)

E



**NON-LOCKING
CASTER (2)**

F



**CASTER BOLT (16)
M10**

G

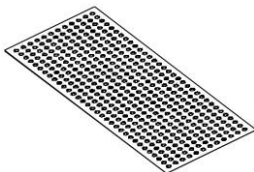

LINER (11)

H



KEY (4)

ASSEMBLY INSTRUCTIONS

STEP 1

Location of parts:

- 1) KEYS (H) are hooked on the key leash that is mounted in the TOP LEFT Drawer.

NOTE: Drawer lock and cabinet lock use different keys, please match code on lock to the code on key.

- 2) CASTERS (D/E) and CASTER BOLTS (F) are boxed and put in the BOTTOM LEFT Drawer.

- 3) LINERS (G) / SIDE HANDLES (B) / HANDLE BOLTS (C) are all in the BOTTOM RIGHT Drawer.

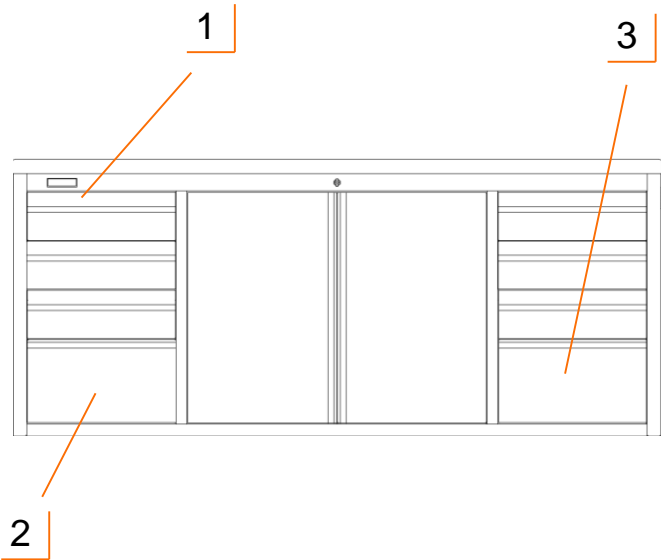

STEP 2

Position SIDE HANDLE (B) over pre-installed nuts on the side of WORKBENCH (A). Insert HANDLE BOLTS (C) through holes on SIDE HANDLE (B). Use a 10mm wrench to tighten HANDLE BOLTS (C) to WORKBENCH (A).

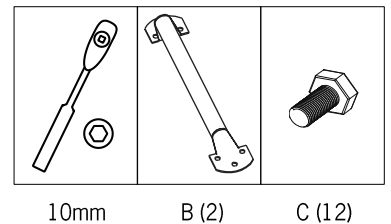

Repeat these instructions to install the other SIDE HANDLE (B).

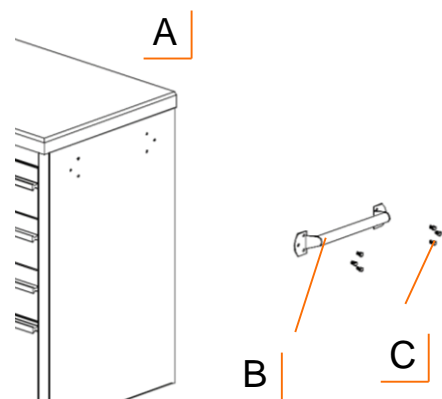
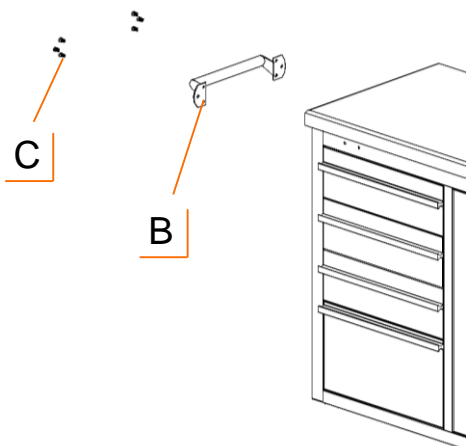

ASSEMBLY INSTRUCTIONS

STEP 3

Lay WORKBENCH (A) on its backside.

Position LOCKING CASTERS (D) on the side of the WORKBENCH (A) of your choice and align holes to pre-installed nuts on the underside of WORKBENCH (A). Use a 14mm socket wrench to tighten CASTER BOLT (F) to WORKBENCH (A).

Repeat above step to install the NON-LOCKING CASTERS (E).

Notes:

* Make sure to install both of the LOCKING CASTERS (E) on the same side.

** For ease of use, place LOCKING CASTERS (E) on the side you will regularly push or pull.

*** If you plan to push the Tool Chest against a wall, place LOCKING CASTERS (E) on the front long side for ease of access.

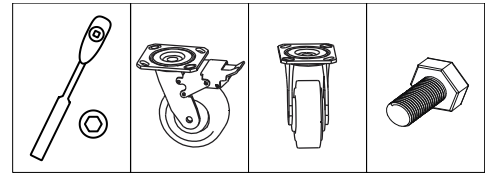

14mm

D (2)

E (2)

F (16)

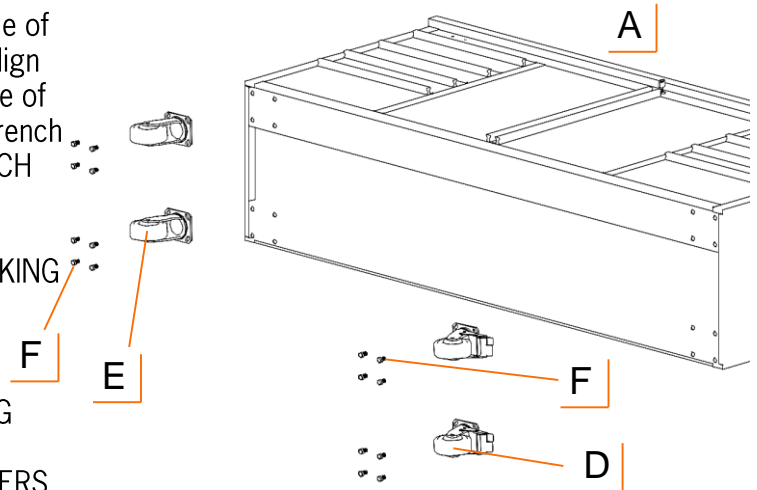

STEP 4

Place LINERS (G) in each drawer and on each shelf.

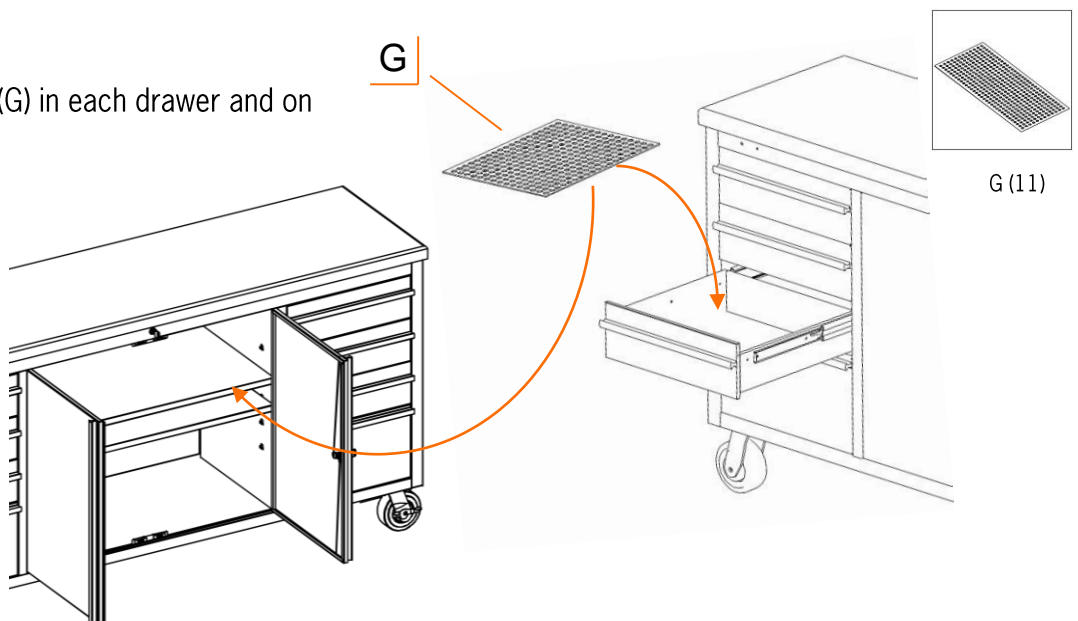

G (11)

USAGE INSTRUCTIONS

DRAWER REMOVAL

Pull the drawer out so that it is almost fully extended. On the RIGHT-hand side, push the black release lever DOWN. On the LEFT-hand side, pull the black release lever UP. While holding the levers as instructed, pull the drawer forward until released from the slides attached to the Tool Chest ("Tool Chest Slides").

Note: The slides attached to the drawer ("Drawer Slides") are an integral part of the drawer and must be removed along with the drawer itself.

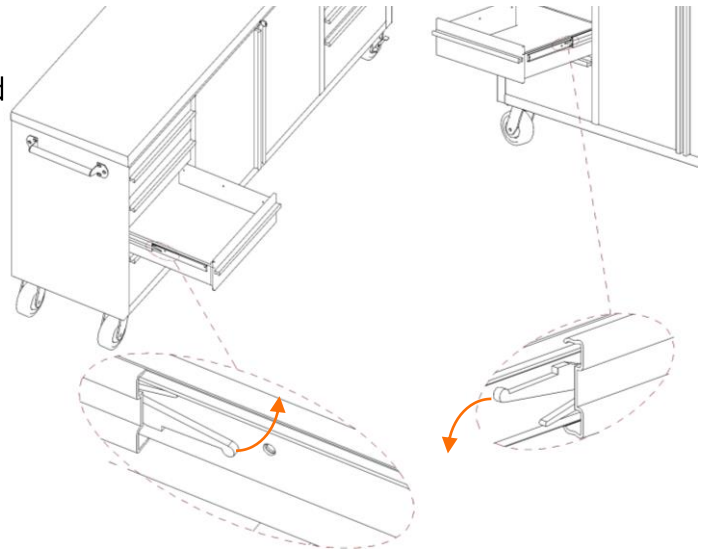

DRAWER REPLACEMENT

To replace the drawer, pull the slides out completely. Insert the brackets on each side of the Drawer Slides into the corresponding slots on the Tool Chest Slides, making sure they are properly positioned. Once the brackets are inserted into the slots, completely close the drawer to set all slides in their proper positions.

SHELF ADJUSTMENT

Ensure all products have been removed from the shelf.

To adjust the shelf height position, tap the underside of the shelf, starting on the right side. Disengage the shelf from the front and back cabinet tabs first from the right side and then from the left.

Tilt the shelf diagonally to move it to the desired position. Once at the desired height, secure the shelf by pushing down on all 4 corners until the shelf engages fully with the tabs.

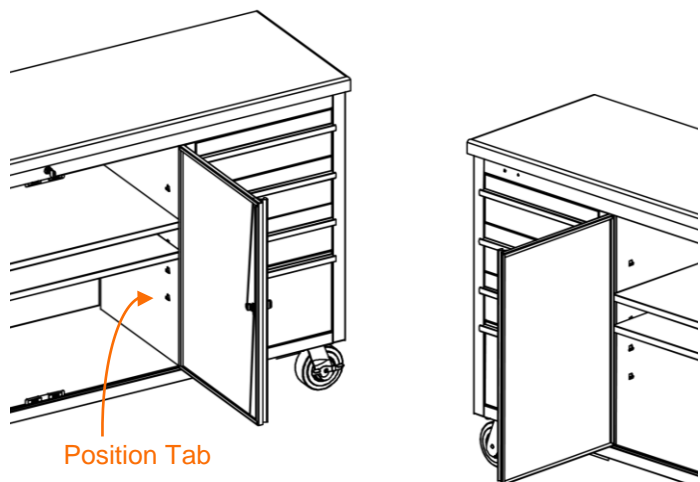

SERVICE PARTS LIST – TLS-7204 / TLS-7205

TRINITY Customer Service provides the following replacement parts:

Part Number	Description	Part Number	Description
1) LNA-06-001-7219	Wood Top	13) AMA-05-019-2350	Door Handle
2) CSV-11-001-0XXX	Lock	14) ZSV-99-002-5020	NonLocking Caster
3) ZSV-01-001-0612	Handle Bolt	15) ZSV-12-001-1575	Slide (drawer side)
4) XSV-05-001-0900	Side Handle	16) AMA-05-019-1500	Drawer Handle
5) XBS-07-001-1705	Small Drawer	17) XBK-23-007-2512	Handle End Cap
6) XBS-07-001-1709	Large Drawer	18) ZSV-12-002-1575	Slide (workbench side)
7) ZSV-01-001-1020	Caster Bolt	19) XBK-22-001-1616	Drawer Liner
8) ZSV-99-001-5020	Locking Caster	20) XBK-22-001-3317	Shelf Liner
9) PBK-03-001-3317	Shelf	21) XBK-02-047-0001	Key leash
10) XBS-08-001-1726	Right Door	22) XBK-10-001-0XXX	Key
11) XBK-02-001-0001	Door Magnet	23) ZBK-01-004-0406	Bracket screw
12) XBS-08-002-1726	Left Door	24) PBK-02-023-0701	Upper magnet bracket

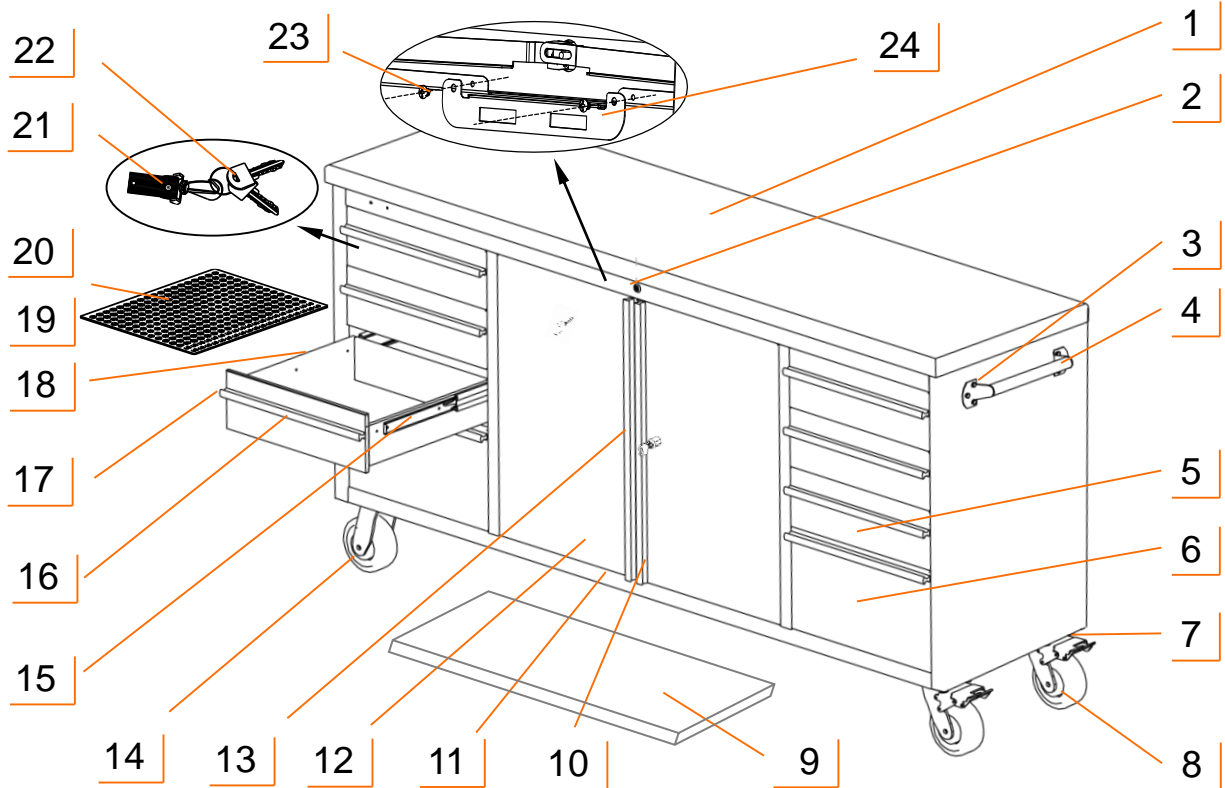

NOTE: Replacement keys may be ordered using the code shown on the face of the lock. The Drawer and Cabinet locks may have different key codes.

WARNINGS

- 1. Read and understand all instructions.** Failure to follow all instructions may result in injury and/or damage.
- 2. The warnings, cautions, and instructions discussed in this manual cannot cover all possible conditions or situations that may occur.** The user must always be aware of their environment and ensure that they use the product in a safe and responsible manner.
- 3. Do NOT modify the product in any way.** Unauthorized modification may impair the function and/or safety of the product, and may affect the life of the product.
- 4. Check for damaged parts.** Before using this product, carefully check that all parts are in good condition, and that the product will operate properly and perform its intended function. Check for damaged parts and any other conditions that may affect the operation of this product. Replace damaged or worn parts, and never use this product with a damaged part.
- 5. Do NOT overload the product.**

Weight capacity per drawer	100 lb
Weight capacity per shelf	75 lb
Total weight capacity of tool chest	1200 lb

- 6. Lock the casters when leaving workbench in stationary position.**
- 7. Lock the drawers and cabinet doors before moving the workbench.**
- 8. Do NOT open more than one drawer at a time.** Tipping can occur.
- 9. Do NOT step or lean on open drawers.** Tipping can occur.
- 10. Do NOT let children play near the workbench.**
- 11. Load the workbench starting with the bottom drawers to prevent workbench from tipping**
- 12. Make sure all drawers are closed tightly before locking or unlocking.**

CARE AND MAINTENANCE

- Avoid harsh, abrasive cleaners, and other corrosive chemicals.
- Do not use scouring pad for cleaning.
- Keep dry and avoid damp environments.
- Use a quality stainless steel cleaner and follow instructions that come with the cleaner. Wipe ALONG the grain (NOT against).
- Wood top can be cleaned with damp cloth and wiped dry immediately with dry cloth. If needed, solvent-based wood furniture cleaner can be used.
- Clean up any spills immediately to prevent stains from forming on the wood top.

PRODUCT REGISTRATION

Thank you for purchasing a TRINITY 72" Rolling Workbench. In order to register your product and receive streamlined customer service, please fill out the following Product Registration Form and (1) fax the form to 310.347.4134 (2) complete the Product Registration Form online at www.trinityii.com or (3) scan and email the form to customerservice@trinityii.com. Include a copy of your original receipt with your submission.

First Name: _____ Last Name: _____

Address: _____

City: _____ State: _____ Zip Code: _____

Email Address: _____ Phone: _____

Product Model #: _____ Purchase Date: ____ / ____ / ____

Location of Purchase: _____

Please rate the importance of each feature (1=least important; 10=most important)

Quality ____ Price ____ Size/Capacity ____ Appearance ____ Other ____

How did you hear about our product?

- Magazine Ad Catalog Salesperson Word of Mouth
 Internet Store Display Other

Marital Status: Single Married

Household Income: Below \$50,000 \$50,000-\$150,000 \$150,000+

Education: High School College Graduate School

Primary Residence: Own Rent

Comments/Suggestions:



1 YEAR LIMITED WARRANTY

TRINITY 72" Rolling Workbench Model # TLS-7204 / TLS-7205

Trinity International Industries ("Trinity") warrants to the original consumer purchaser ("Purchaser") of the TRINITY 72" Rolling Workbench ("Product") that each Product shall be free from defects in workmanship and materials for a period of 1 year from the date of original purchase. Trinity's obligation under this warranty shall be limited to repair or replacement of, or adequate compensation for the Product which shall not be greater than the amount of the purchase price of the Product, at the option of Trinity, during the warranty period. All replaced parts and Products become the property of Trinity and must be returned to Trinity.

This warranty excludes normal wear and tear of the Product and its parts or components, and damage arising from any of the following: negligent use or misuse of the Product, use contrary to this User's Manual, or alteration by any one other than Trinity. The warranty period of 1 year shall not be extended or renewed by the repair or replacement of, or compensation for, the Product. Any warranty implied by applicable law is limited in duration to one year from the date of purchase and is subject to the same conditions and limitations as is provided for our express warranty.

Except as set forth herein, and to the extent of applicable there are no warranties on this Product either express or implied, and Trinity disclaims all warranties including, but not limited to, any implied warranties of merchantability, infringement or fitness for a particular purpose. No warranty or guarantee given by any person, firm, or corporation with respect to this product shall be binding on Trinity.

If your Product is defective or otherwise requires service or parts, please call TRINITY Customer Service toll-free at (800) 985-5506, between 5:00 a.m. and 5:00 p.m., PST. Please tell us which model you purchased, the date of the purchase, and the problem with your Product. A copy of your original purchase receipt must accompany your service request.

LIMITATION OF REMEDIES AND LIABILITY

Trinity (and its employees, officers, members, managers, affiliates and assigns) shall not be liable for any incidental, consequential, special, indirect, remote, special or punitive damages for breach of any warranty, express or implied, including, but not limited to, lost profits, lost savings, loss of anticipated benefits and attorneys' fees, which arise out of the purchase, use or inability to use the Product, whether arising out of contract, negligence, strict tort, product liability, or any other legal theory on which a claim is based. As noted above, to the extent damages are allowed by our express warranty or by applicable law, those damages may not exceed the purchase price paid for the Product. Without limiting the foregoing Purchaser assumes all risk and liability for loss, damage or injury to Purchaser and Purchaser's property and to others and their property arising out of the use, misuse, or inability to use this Product. This limited warranty shall not extend to anyone other than the original purchaser of this product, is nontransferable and states your exclusive remedy.

Some states do not allow the exclusion or limitation of incidental, consequential, special, or punitive damages, so the above limitation or exclusion may not apply to you. The above warranty gives you specific legal rights, and you may have other rights which vary from state to state.

CONTACT US

**QUESTIONS? NEED PARTS?
WE ARE HERE TO HELP!**

Please feel free to contact us. There are no questions too small, or any problems too big. We're committed to providing our customers with the highest level of service.

TRINITY Customer Service

TEL: 800.985.5506

FAX: 310.347.4134

EMAIL: customerservice@trinityii.com

**Monday through Friday
5:00 AM – 5:00 PM (PST)**

www.trinityii.com