

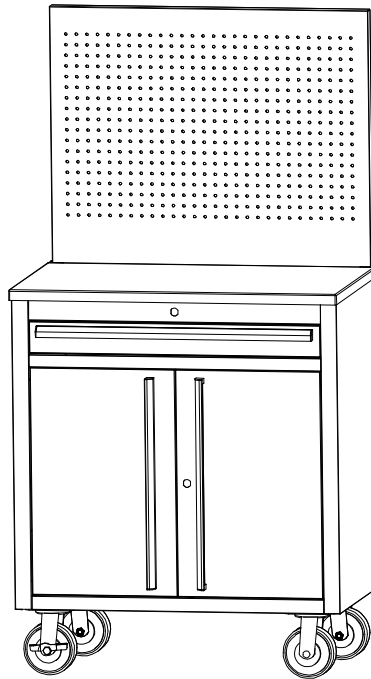

OWNER'S MANUAL



TRINITY BASICS STAINLESS STEEL WORKBENCH W/ PEGBOARD

Model # TLS-4820



Important / Important / Importante

FOR QUICK & EASY 3D ASSEMBLY INSTRUCTIONS

POUR DES DIRECTIVES D'ASSEMBLAGE 3D RAPIDES ET FACILES

PARA INSTRUCCIONES DE ENSAMBLAJE RÁPIDAS Y SENCILLAS EN 3D

BILT.[®]

Intelligent Instructions
Directives intelligentes
Instrucciones Inteligentes



DOWNLOAD THE FREE APP | TÉLÉCHARGER L'APPLICATION GRATUITE | DESCARGUE LA APLICACIÓN GRATUITA

PARTS LIST

Your TRINITY Basics Stainless Steel Workbench w/ Pegboard should include the following parts. Please inspect box contents to ensure you have received all components.

If you are missing any parts, need assistance with assembly or have questions, please contact TRINITY Customer Service: 800.985.5506 or customerservice@trinityii.com. Parts can also be requested online via "Contact Us" section at www.trinityii.com.

You will need 14mm wrench (for casters) and 12mm wrench (for pegboard) for assembly. These are NOT included.

A

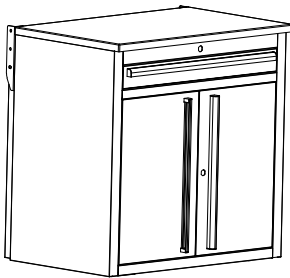

**WORKBENCH
w/PEGBOARD (1)**

B

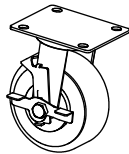

**LOCKING
CASTER (2)**

C

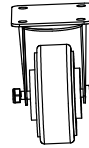

**NON-LOCKING
CASTER (2)**

D



**CASTER
BOLT (16)
M10**

E

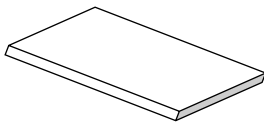

SHELF (1)

F

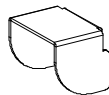

**SHELF
SUPPORT (4)**

G



LINER (3)

H



KEY (4)

I

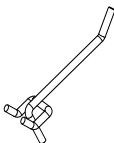

HOOK (10)

ASSEMBLY INSTRUCTIONS

STEP 1

Location of parts:

- 1) KEYS (H) are hooked to key leash mounted inside Drawer.
- 2) LINERS (G) are inside Drawer.
- 3) CASTERS (B/C) / CASTER BOLTS (D) / SHELF SUPPORTS (F) and HOOKS (I) are boxed inside Cabinet.
- 4) SHELF (E) is inside bottom Cabinet.

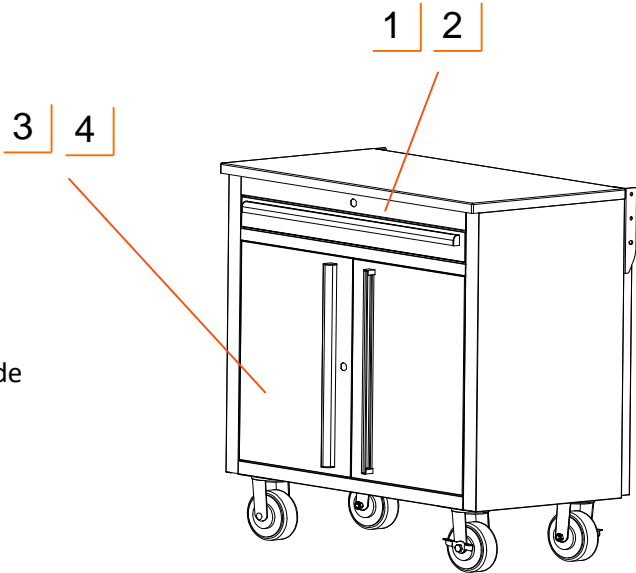

STEP 2

With two people, carefully lay WORKBENCH (A) on its backside. Do NOT attempt this alone.

Position LOCKING CASTERS (B) on side of WORKBENCH (A) of your choice and align holes to pre-installed nuts on underside of WORKBENCH (A). Use a 14mm socket wrench to fully tighten CASTER BOLT (D) to WORKBENCH (A).

Repeat above steps to install NON-LOCKING CASTERS (C).

Notes:

- * Make sure to install both LOCKING CASTERS (B) on same side of workbench, either left or right side. Do NOT install both on front or back side.
- ** For ease of use, place LOCKING CASTERS (B) on side you will regularly push.
- *** If you plan to push the workbench against a wall, push NON-LOCKING CASTER (C) against the wall first then swing LOCKING CASTERS (B) against the wall.

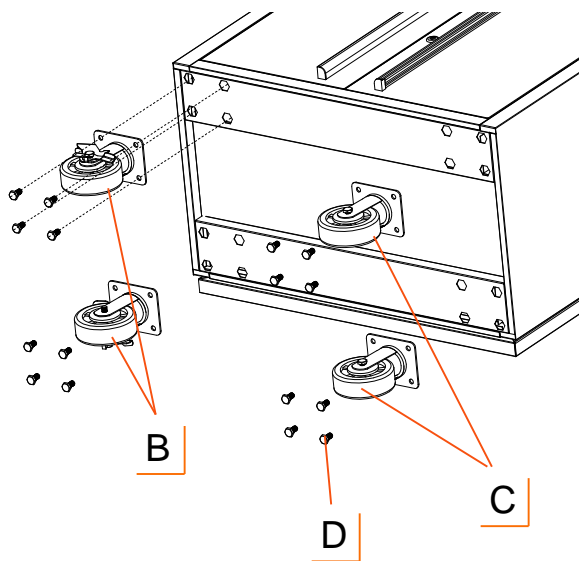
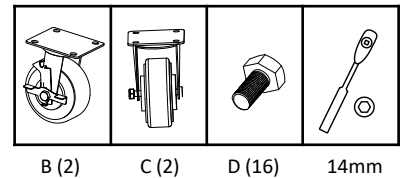

ASSEMBLY INSTRUCTIONS

STEP 3

Carefully lift Workbench upright. Two people are needed. Do NOT attempt this alone.

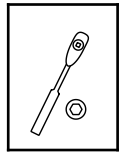

12mm

Unscrew bottom Bolt on left and right side of Pegboard with a 12mm socket wrench. Lift Pegboard upright. With one person holding Pegboard in place, have second person insert bottom Bolt into top hole of each bracket. Securely tighten both Bolts back with socket wrench.

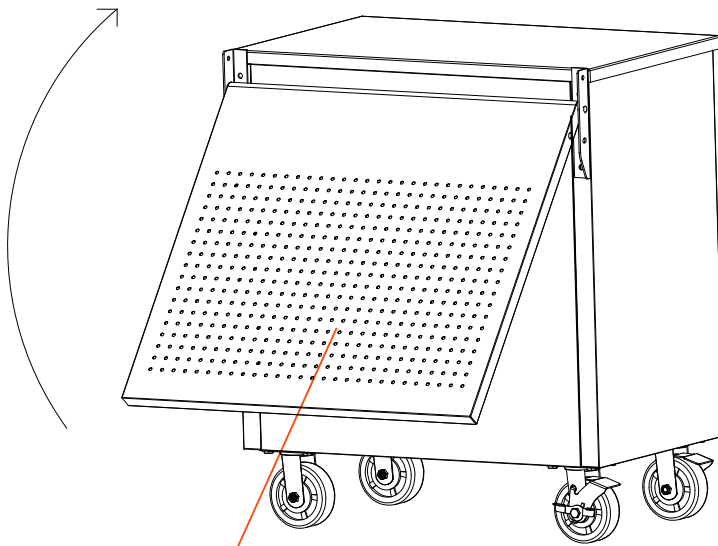

PEGBOARD

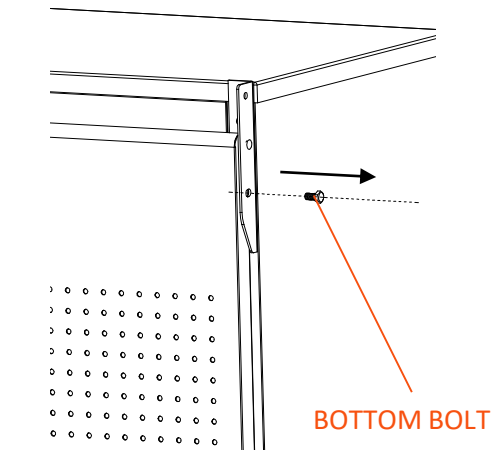

BOTTOM BOLT

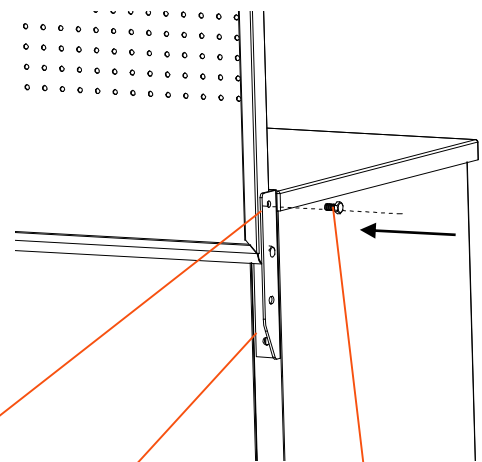

TOP HOLE

BOTTOM BOLT

BRACKET

ASSEMBLY INSTRUCTIONS

STEP 4

SHELF (E) is shipped inside the bottom cabinet. Tilt SHELF (E) diagonally and remove it from cabinet.

Attach SHELF SUPPORT (F) by hooking it over position tab at desired height. Make sure all four SHELF SUPPORTS (F) are at same level. Tilt SHELF (E) diagonally to move it inside cabinet. Place SHELF (E) on top of all four SHELF SUPPORTS (F).

You can adjust shelf height position by removing shelf, re-locating shelf supports and replacing shelf.

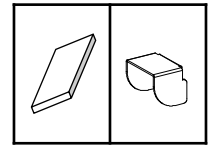

E (1) F (4)

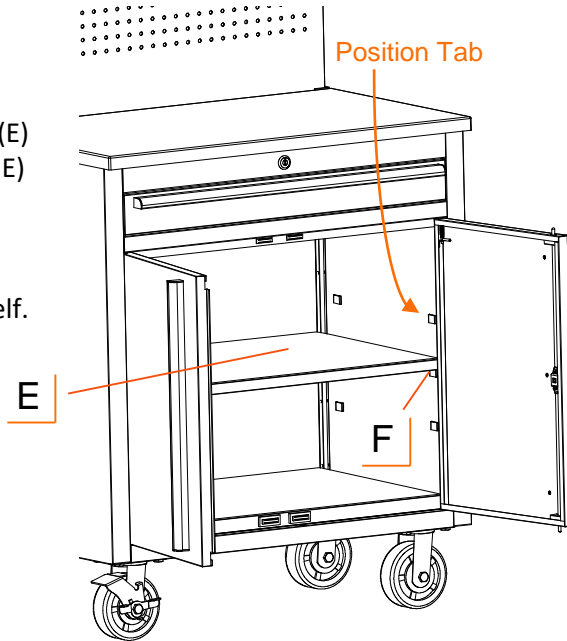

STEP 5

Place LINERS (G) inside drawer, on cabinet shelf and on bottom of cabinet.

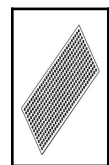

G (3)

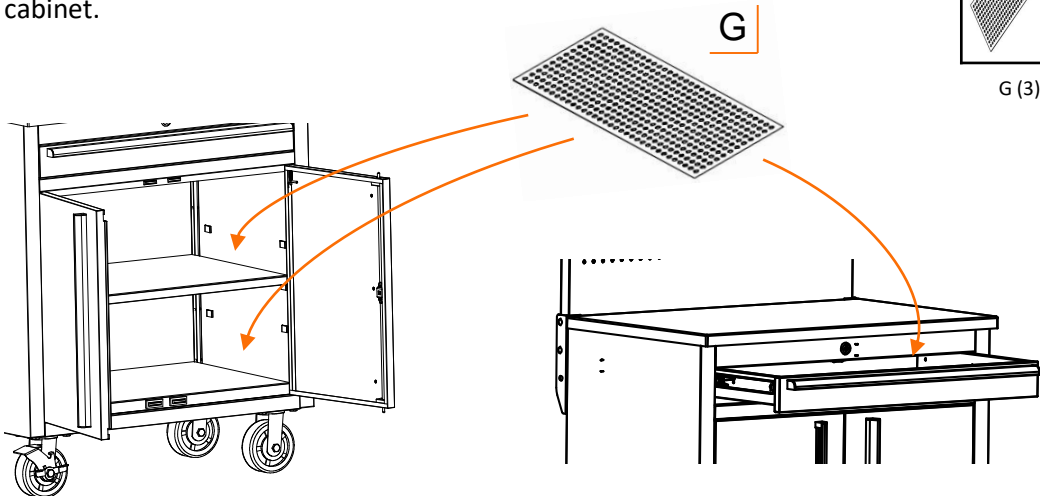

ASSEMBLY INSTRUCTIONS

STEP 6

Hang HOOKS (I) into holes on pegboard at your desired location.

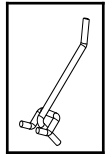

I (10)

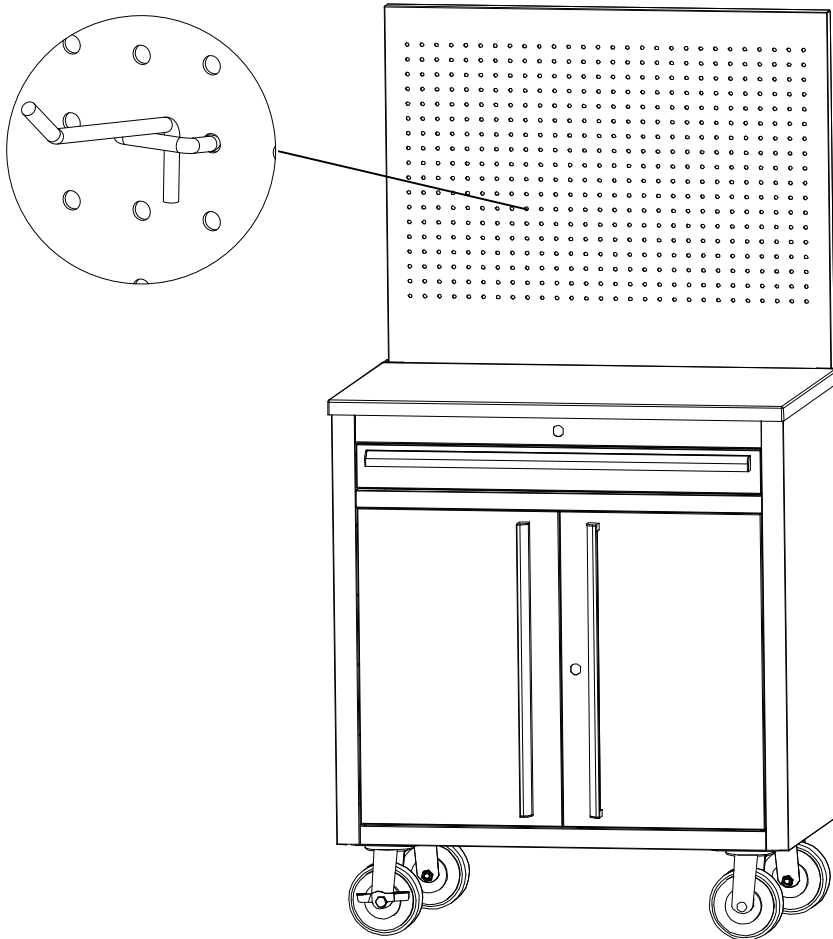

USAGE INSTRUCTIONS

DRAWER REMOVAL

Pull drawer out so that it is almost fully extended. On RIGHT-hand side, push black release lever DOWN. On LEFT-hand side, pull black release lever UP. While holding levers as instructed, pull drawer forward until released from slides attached to Workbench ("Workbench Slides").

Note: Slides attached to drawer ("Drawer Slides") are an integral part of drawer and must be removed along with drawer itself.

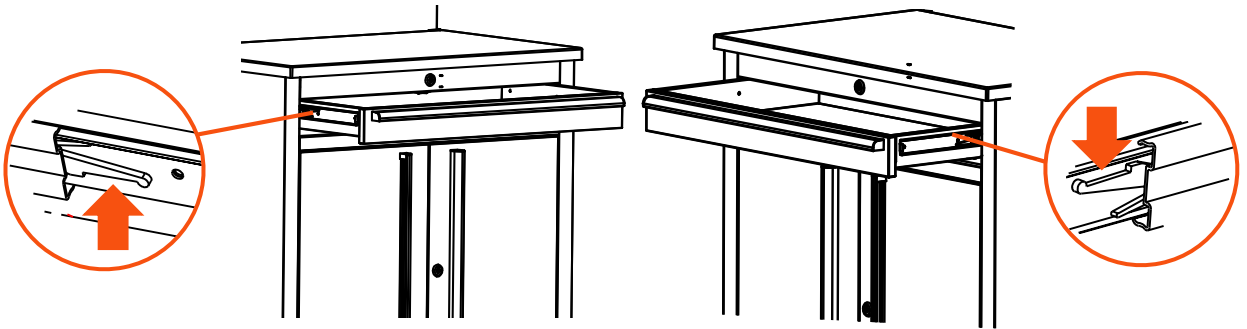

DRAWER REPLACEMENT

To replace drawer, pull slides out completely. Insert brackets on each side of Drawer Slides into corresponding slots on Workbench Slides, making sure they are properly positioned. Once brackets are inserted into slots, completely close drawer to set all slides in their proper positions.

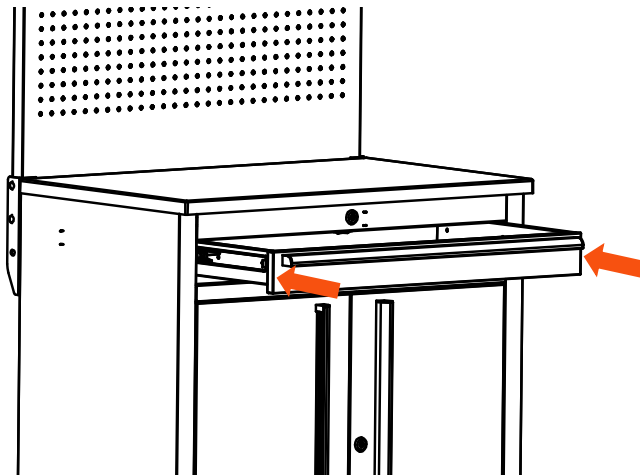

SERVICE PARTS LIST – TLS-4820

TRINITY Customer Service provides the following replacement parts:

	Part Number	Description		Part Number	Description
1)	XBK-02-047-0001	Key leash	13)	XBK-22-007-2717	Shelf Liner
2)	XBK-10-001-0XXX	Key	14)	ZSV-99-004-5020	Locking Caster
3)	XBS-07-013-2716	Drawer	15)	XBS-08-015-2114	Left Door
4)	LNA-06-015-3119	Wood Top	16)	AMA-05-007-2000	Door Handle
5)	ZSV-12-010-1575	Slide (workbench side)	17)	XBK-23-010-3012	End cap
6)	AMA-05-007-2600	Drawer Handle	18)	XBS-19-011-0825	Pegboard Bracket-Right
7)	XBS-08-014-2114	Right Door	19)	XBS-19-008-0825	Pegboard Bracket- Left
8)	XSV-02-017-0001	Shelf Support	20)	XSV-01-009-0816	Pegboard Bolt
9)	PBK-03-001-2717	Shelf	21)	CSV-11-001-0XXX	Lock
10)	ZSV-99-003-5020	Non-locking Caster	22)	ZSV-12-009-1575	Slide (drawer side)
11)	ZSV-01-001-1020	Caster Bolt	23)	PBK-15-016-3024	Pegboard
12)	XBK-22-007-1626	Drawer Liner	24)	ZSV-02-025-0001	Hook

SERVICE PARTS LIST – TLS-4820

TRINITY Customer Service provides the following replacement parts:

NOTE: Replacement keys may be ordered using the code shown on the face of the lock.

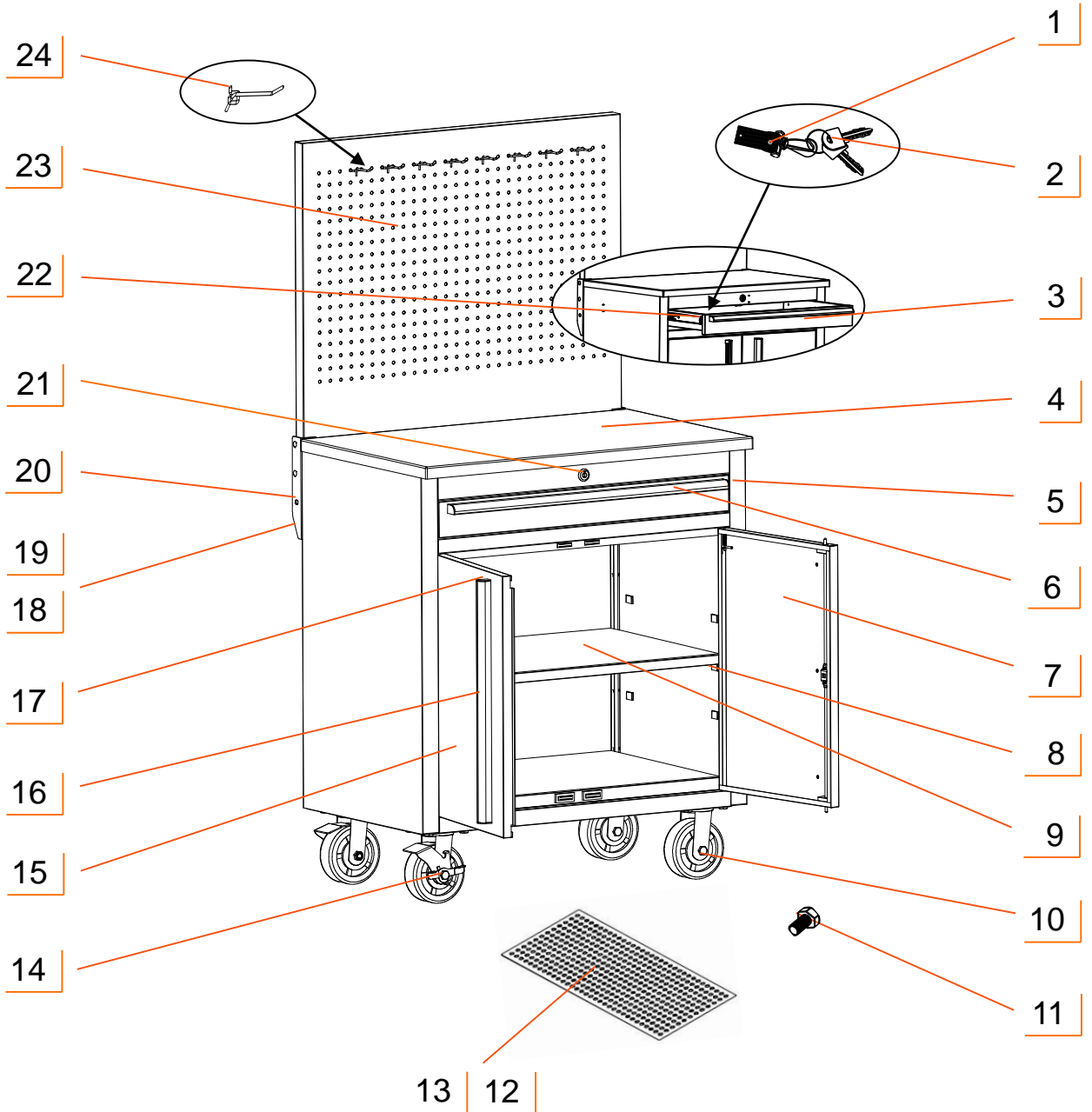

WARNINGS

1. **Read and understand all instructions.** Failure to follow all instructions may result in injury and/or damage.
2. **The warnings, cautions, and instructions discussed in this manual cannot cover all possible conditions or situations that may occur.** The user must always be aware of their environment and ensure that they use the product in a safe and responsible manner.
3. **Do NOT modify the product in any way.** Unauthorized modification may impair the function and/or safety of the product, and may affect the life of the product.
4. **Check for damaged parts.** Before using this product, carefully check that all parts are in good condition, and that the product will operate properly and perform its intended function. Check for damaged parts and any other conditions that may affect the operation of this product. Replace damaged or worn parts, and never use this product with a damaged part.
5. **Do NOT overload the product.** Below capacity is based on evenly distributed weight.

Weight capacity per drawer	34 kg / 75 lb
Weight capacity per shelf	22.7 kg / 50 lb
Weight capacity per hook	4.5 kg / 10 lb
Total weight capacity of pegboard	90.7 kg / 200 lb
Total weight capacity of workbench	453.6 kg / 1000 lb

6. **Lock the casters when leaving workbench in stationary position.**
7. **Lock the drawer and cabinet and remove all items from the pegboard before moving the workbench.**
8. **Move workbench by pushing and NOT pulling.** Roll slowly and constantly check surroundings to ensure enough clearance. Heavy weight workbench can be hard to stop if moving too fast, causing serious injury or damage.
9. **Do NOT step or lean on open drawer or open cabinet.** Tipping can occur.
10. **Do NOT hang on the Pegboard.**
11. **Ensure pegboard bolts are always securely tightened.** Check regularly to ensure the bolts have not loosened during use of workbench.
12. **Do NOT let children play near the workbench.**

WARNINGS

13. Load the workbench starting with the bottom of cabinet to prevent workbench from tipping.
14. Make sure the drawer and/or doors are closed tightly before locking or unlocking.

CARE AND MAINTENANCE

- Avoid harsh, abrasive cleaners, and other corrosive chemicals.
- Do not use scouring pad for cleaning.
- Keep dry and avoid damp environments.
- Use a quality stainless steel cleaner and follow instructions that come with the cleaner. Wipe ALONG the grain (NOT against).
- Wood top can be cleaned with damp cloth and wiped dry immediately with dry cloth. If needed, solvent-based wood furniture cleaner can be used.
- Clean up any spills immediately to prevent stains from forming on the wood top.





1 YEAR LIMITED WARRANTY

TRINITY Basics Stainless Steel Workbench w/Pegboard Model # TLS-4820

Trinity International Industries (“Trinity”) warrants to the original consumer purchaser (“Purchaser”) of the TRINITY Basics Stainless Steel Workbench w/ Pegboard (“Product”) that each Product shall be free from defects in workmanship and materials for a period of 1 year from the date of original purchase. Trinity’s obligation under this warranty shall be limited to repair or replacement of, or adequate compensation for the Product which shall not be greater than the amount of the purchase price of the Product, at the option of Trinity, during the warranty period. All replaced parts and Products become the property of Trinity and must be returned to Trinity.

This warranty excludes normal wear and tear of the Product and its parts or components, and damage arising from any of the following: negligent use or misuse of the Product, use contrary to this User’s Manual, or alteration by any one other than Trinity. The warranty period of 1 year shall not be extended or renewed by the repair or replacement of, or compensation for, the Product. Any warranty implied by applicable law is limited in duration to one year from the date of purchase and is subject to the same conditions and limitations as is provided for our express warranty.

Except as set forth herein, and to the extent of applicable there are no warranties on this Product either express or implied, and Trinity disclaims all warranties including, but not limited to, any implied warranties of merchantability, infringement or fitness for a particular purpose. No warranty or guarantee given by any person, firm, or corporation with respect to this product shall be binding on Trinity.

If your Product is defective or otherwise requires service or parts, please call TRINITY Customer Service toll-free at (800) 985-5506, between 5:00 a.m. and 5:00 p.m., PST. Please tell us which model you purchased, the date of the purchase, and the problem with your Product. A copy of your original purchase receipt must accompany your service request.

LIMITATION OF REMEDIES AND LIABILITY

Trinity (and its employees, officers, members, managers, affiliates and assigns) shall not be liable for any incidental, consequential, special, indirect, remote, special or punitive damages for breach of any warranty, express or implied, including, but not limited to, lost profits, lost savings, loss of anticipated benefits and attorneys’ fees, which arise out of the purchase, use or inability to use the Product, whether arising out of contract, negligence, strict tort, product liability, or any other legal theory on which a claim is based. As noted above, to the extent damages are allowed by our express warranty or by applicable law, those damages may not exceed the purchase price paid for the Product. Without limiting the foregoing Purchaser assumes all risk and liability for loss, damage or injury to Purchaser and Purchaser’s property and to others and their property arising out of the use, misuse, or inability to use this Product. This limited warranty shall not extend to anyone other than the original purchaser of this product, is nontransferable and states your exclusive remedy.

Some states do not allow the exclusion or limitation of incidental, consequential, special, or punitive damages, so the above limitation or exclusion may not apply to you. The above warranty gives you specific legal rights, and you may have other rights which vary from state to state.

CONTACT US

**QUESTIONS? NEED PARTS?
WE ARE HERE TO HELP!**

Please feel free to contact us. There are no questions too small, or any problems too big. We're committed to providing our customers with the highest level of service.

TRINITY Customer Service

TEL: 800.985.5506

FAX: 310.347.4134

EMAIL: customerservice@trinityii.com

**Monday through Friday
5:00 AM – 5:00 PM (PST)**

www.trinityii.com