



User Manual Pistol Keypad Biometric Safe

Read all instructions before using this safe.

WARNING

- Safe can be opened by Fingerprint, PIN code, and/ or Emergency keys.
- Avoid leaving door open and unattended; it will allow unauthorized individuals to reprogram the safe, gaining full access to the safe and the contents.
- Store emergency keys in a secure place; NOT inside of the safe.
- Be aware of the load bearing. Failure to do so can result in personal injury and/ or damage to property. Use appropriate tools when performing work and always use eye protection.
- When mounting the safe, make sure that the compartment has enough space to drop open. The compartment requires gravity to fully release, always install in a vertical position.
- To maximize the security and performance of the safe, test registered fingerprints every 6 months.
- Keep safe away from children.

NOTE: BARSKA is not responsible if the safe or its contents gets lost or stolen

Parts

- A. Mounting Bracket
- B. Indicator Light
- C. Keypad and Fingerprint Scanner
- D. Key Access
- E. Initialization Button
- F. Battery Compartment
- G. Mounting Area

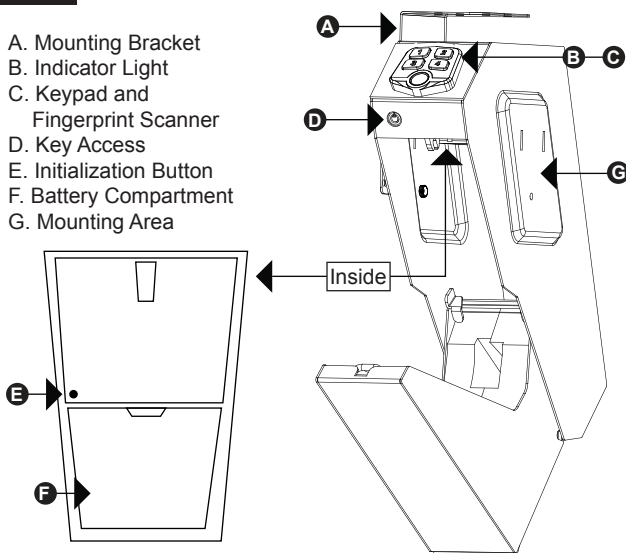

Getting Started

1. Remove safe from packaging and remove Manual and all accessories that came with the safe.
2. Open pistol safe with emergency keys and install 4AA batteries. Pay attention to the polarity of the batteries.

NOTE: Do not mix new and old batteries

Pin Code Registration

1. With safe open, press and hold the initialization button inside the safe until 2 beeps heard and light on keypad come on. Then, release the button.
2. Enter new desired 4 digits Pin Code and you will hear 2 beeps. Then, enter the same Pin Code again and 2 beeps are heard. New Pin Code is registered successfully.

NOTE: Default Pin Code is 1234. Once the Pin Code has been registered with New Pin Code, the default Pin Code will be replaced.

3. If the registration is unsuccessful, 5 beeps will be heard.

Fingerprint Registration

1. With safe open, press and hold the initialization button inside the safe until 2 beeps heard and light on keypad come on. Then, release the button.
2. Place desired finger on fingerprint scanner. When 2 beeps are heard, remove the finger. Fingerprint is registered successfully.
3. If the registration is unsuccessful, 5 beeps will be heard.
4. To delete the registered fingerprint, press and hold the initialization button until SECOND 2 beeps heard. Then, the fingerprint record has been deleted. No fingerprint can open the safe.

Close/Open Safe Door

Press registered Pin Code or fingerprint. When the green light comes on, the safe door should open.

NOTE: If green light and blue light of keypad come on together, it means that power is low and it needs to change the batteries.

Sound Option

Sound Off

Press and hold 1 of keypad for 3 seconds to turn sound off. The safe can be operated under silence mode.

Sound On

To turn on the sound, press and hold 1 again of keypad for 3 seconds. The sound will be back.

Lock Mode

Safe will be in lock mode if user enters incorrect Pin Code or put wrong fingerprint three times. Under lock mode, keypad and fingerprint scanner don't work for 2 minutes. Keypad and fingerprint scanner will be able to work again after 2 minutes.

Mounting

- a. Mounting Bracket Hole
- b. Thumb Screw Hole
- c. Wall Mounting Hole

Mounting Holes Of The Safe

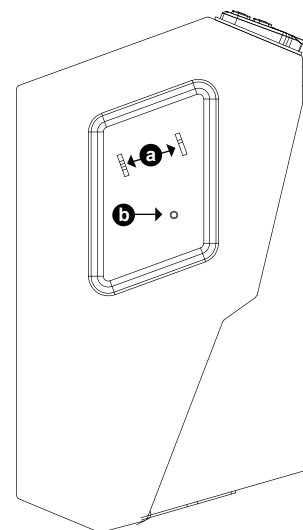

Mounting Holes Of The Mounting Bracket

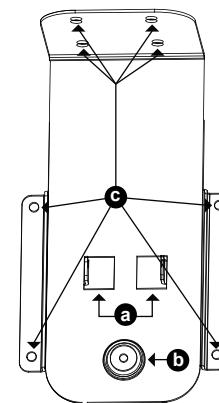

The safe can be mounted from the left or right with the included mounting bracket.

Use proper drill tools and mounting hardware for the type of surface you are mounting the safe too. Included screws are designed to be used on wood surfaces.

1. Open the safe with the pin code or key.
2. Unscrew the thumbscrews located on the inside of the safe.
3. Remove the bracket by sliding it down and off of the safe.
4. Use the wall mounting holes on the side or top of the mounting bracket to mark the desired mounting location.
5. Use appropriate mounting hardware to screw the bracket into desired location.
6. Slide the safe onto the bracket screw in thumbscrews located on the inside of the safe.
7. Close the safe

The safe is now ready to be used.

Note: All information, feature, and specification displayed herein are based on the data available at the time of publishing, thus they are subject to change without notice. All product pictures displayed herein are for illustration purposes only. The actual product may vary due to different circumstances.



1 YEAR LIMITED WARRANTY

SAFE/LOCK BOX

BARSKA warrants this new safe/lock box to be free of defects in material and/ or workmanship under normal use for a period of twelve (12) months from the date product is purchased. This limited warranty is delimited to repair or replacement only. This warranty does not cover damage caused by improper installation or maintenance. BARSKA disclaims all liability for incidental or consequential damages resulting from misuse, abuse, accident (such as dropping), fire, flood, service or repairs other than those performed by BARSKA, acts of nature, or arising out of any breach of this warranty. Altering the product under any circumstances will automatically void the warranty.

For service under this limited warranty, please have available the proof of purchase and the purchase date and location as well as a detailed description of the problem. This warranty is not transferable and only applies to the original purchaser with a proof of purchase from BARSKA or from an authorized dealer. This warranty applies only to products purchased within the United States, excluding Alaska, the Hawaiian Islands and all U.S. territories in the Caribbean and the Pacific.

BARSKA will examine and go through troubleshooting procedures, product repair or replacement of defective part(s) or units with new part(s) or provide a new unit, if necessary, during the warranty period. Reasonable shipping/handling charges may apply and are based on Barska sole discretion. Purchaser shall be required to prepay Shipping/handling charges with a check or money order to BARSKA at time product is returned. The Return Merchandise Authorization Number (RMA#) and shipping/handling charge MUST be obtained from BARSKA in advance of return. BARSKA shall not be liable for damages or loss occurring during shipping. Please visit via www.barska.com or call 909.445.8168 to obtain the RMA#, Shipping/handling amount, and for more information.

BARSKA reserves the right to modify or discontinue, without prior notice to the purchaser, any model or style of the product. BARSKA will determine, at its sole discretion, whether a product will be repaired or replaced. BARSKA reserves the right to discontinue or change any feature of its products at any time. If an exact replacement or product is not available, BARSKA reserves the right to provide a part or product that matches as closely as possible.

LIMITATION OF REMEDIES

BARSKA disclaims any warranties, express or implied, whether of merchantability or fitness for a particular use, except as expressly set forth herein. The sole obligation of BARSKA under this limited warranty shall be to repair or replace the covered product, in accordance with the terms set forth herein. BARSKA expressly disclaims any lost profits, general, special, indirect or consequential damages which may result from breach of any warranty, or arising out of the use or inability to use any BARSKA product. Any warranties which are implied and which cannot be disclaimed shall be limited in duration to a term of one year from the date of original retail purchase.

Some states do not allow the exclusion or limitation of incidental or consequential damages or limitation on how long an implied warranty lasts, so the above limitations and exclusions may not apply to you.

BARSKA
855 Towne Center Drive, Pomona, CA 91767