



OWNER'S MANUAL

DEHUMIDIFIER



CONTENTS



Safety Precautions	Page 2
Identification of Parts	Page 5
Operating Instructions	Page 7
Care and Maintenance	Page 14
Troubleshooting Tips	Page 15

MODEL
2PFD22
2PFD35
2PFD50
2PFDP50

SAFETY PRECAUTIONS

Read these safety precautions before installation and operation.

For your safety, it is important that you read and follow the instructions in this manual to minimize the risk of personal injury, fire or electrical shock.

	Warning	This symbol shows that this appliance uses a flammable refrigerant. If a refrigerant leak occurs and is exposed to an external ignition source, there is a risk of fire.
	Caution	This symbol shows that the operation manual should be read carefully.
	Warning	This symbol shows that a service personnel should be handling this equipment with reference to the installation manual.



California Proposition 65 Warning

WARNING: Cancer and reproductive harm - P65warnings.ca.gov

CAUTION

- This dehumidifier is intended for indoor residential use only and should not be used for commercial or industrial applications. Do not use outdoors
- Do not place the unit near a heat source or other heat generating appliances such as clothes dryer, heater or radiator
- Do not attempt to disassemble or repair the unit by yourself.
- Do not use or store the dehumidifier near flammable gas or combustibles, such as gasoline, benzene thinner, or other chemicals, etc.
- Do not drink or use the water collected from the unit.
- Do not remove the water bucket during operation.
- Do not use the unit in small cramped spaces that are not well ventilated
- Do not store or use in areas where water may splash onto the unit.
- Place the unit on a level, sturdy section of the floor .
- Do not cover the intake or exhaust openings.
- Never insert your finger or other foreign objects into grills or openings. Take special care to warn children of these dangers.
- Do not climb or sit on the unit.
- Always insert the filters securely. Clean filter once every two weeks. If water enters the unit, turn the unit off and disconnect the power , contact a qualified service technician
- Do not place foreign objects on the unit.
- The dehumidifier must be operated in an enclosed area to be most effective
- Close all doors, windows and other outside openings to the room.
- When first using the dehumidifier , operate the unit continuously 24 hours. Make sure the plastic cover on the continuous drain hose outlet is fitted properly so there are no leaks.
- This unit is designed to operate with a working environment between 5 C/41 F and 32 C/90 F, and between 30%(RH) and 80%(RH).

WARNING: FOR YOUR SAFETY

- The dehumidifier should not be stored in a room with continuously operating ignition sources (for example: open flames, an operating gas appliance or an operating electric heater)
- Do not pierce or burn this dehumidifier
- Be aware that the refrigerant contained within this dehumidifier is odorless
- Appliance should be installed, operated and stored in a room with a floor area larger than 50ft².
- Compliance with national gas regulations shall be observed.
- Keep ventilation openings clear of obstruction.
- Servicing shall only be performed by an authorized service provider recommended by the equipment manufacturer.
- Maintenance and repair requiring the assistance of other skilled personnel shall be carried out under the supervision of the person competent in the use of flammable refrigerants.

NOTE ABOUT FLUORINATED GASES (NOT APPLICABLE TO THE UNIT USING R290 REFRIGERANT)



- Fluorinated greenhouse gases are contained in hermetically sealed equipment. For specific information on the type, the amount and the CO₂ equivalent in tons of the fluorinated greenhouse gas (on some models), please refer to the relevant label on the unit itself.
- Installation, service, maintenance and repair of this unit must be performed by a certified technician
- Recycling must be performed by a certified technician

IDENTIFICATION OF PARTS

BEFORE YOU BEGIN



NOTE: All the illustrations in the manual are for explanation purpose only. Your dehumidifier may be slightly different. The design specifications are subject to change without prior notice. Consult with the customer service for details. The most up-to-date versions of the manual can be found on the service website. Please check for the latest version.

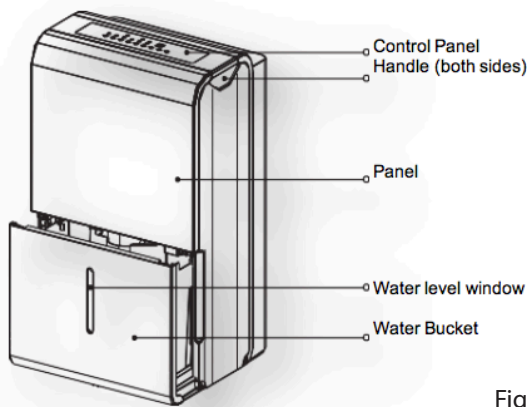
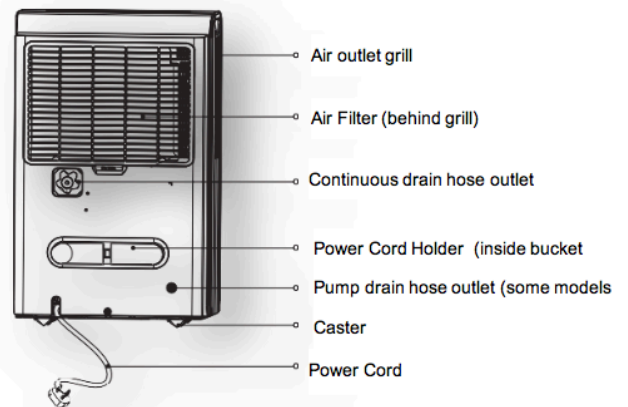

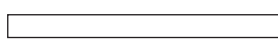

Fig 1



Accessories (shipped in the bucket of the unit)

<p>Power Cord Holder (1PC)</p>  <p>Fig 2</p>	<p>Female Threaded Connector (1PC) (some models)</p> 	<p>Pump Drain Hose (1PC) (some models)</p> 
---	--	--

Power Cord Holder Installation

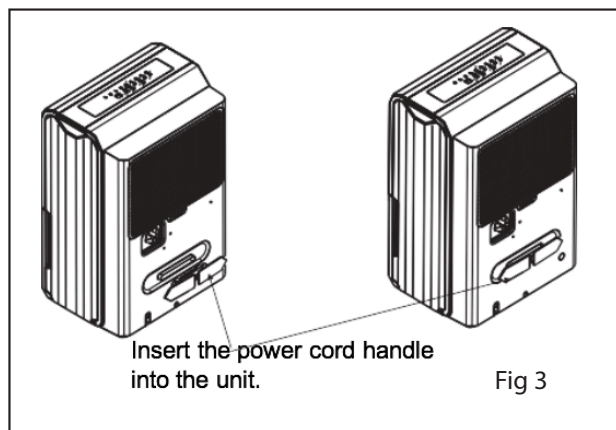

Fig 3

POSITIONING THE UNIT

This dehumidifier should not be used for commercial or industrial applications.

Place the dehumidifier on a smooth, level floor strong enough to support the unit with a full bucket of water.

For good air circulation, allow at least 8 inches of air space on all sides of the unit and a minimum of 16 inches of air space at the air outlet (Fig. 4)

Place the unit in an area where the temperature will not fall below 41^oF (5^oC) because low temperature could cause the coil to freeze.

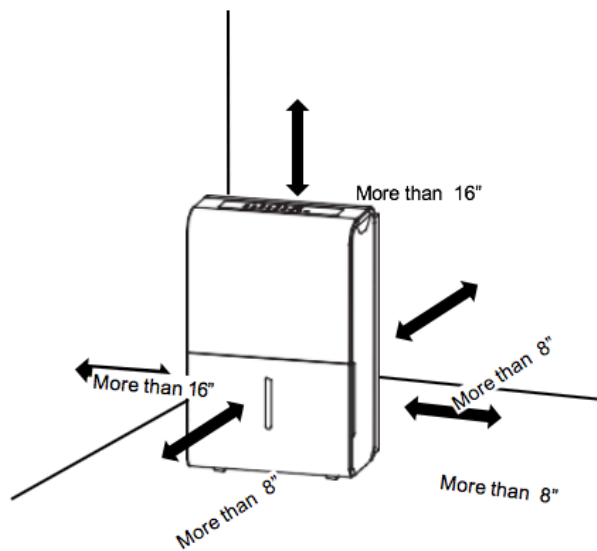

Casters: (Four casters on the bottom of the unit)

- Casters can move freely.
- Do not force the casters to move over carpet or when there is water in the bucket as this may lead to tipping and spillage.

Fig 4.

OPERATING INSTRUCTIONS

Control Panel Features:



Note: The following control panels are for explanation purpose only. The control panel of the unit you purchased may be slightly different according to the models. Your machine may not contain some indicators or buttons. The actual shape shall prevail.

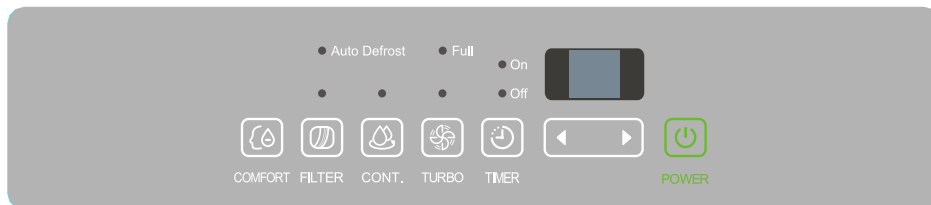

2PFD22, 2PFD35, 2PFD50

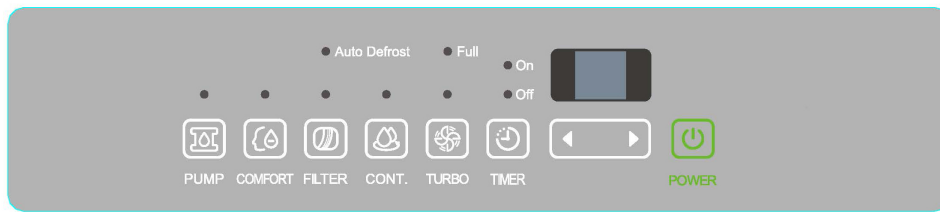

2PFDP50



COMFORT

COMFORT Button

- This dehumidification setting automatically keeps the humidity level in the room between 45%-55% relative humidity (based on room temperature).
- When operating in this mode the touch pad
- (◀ ▶) will be deactivated and you will NOT be able to set a desired humidity level.



FILTER

FILTER Button

- The FILTER light (clean filter indicator light) will illuminate after 250 hours of fan motor operation. This feature is a reminder to clean the air filter for more efficient operation of the dehumidifier.
- Reset the timer after cleaning the filter by pressing and holding the FILTER button until the light goes off



CONTINUE button

CONT.

- Press to activate the continuous dehumidifying operation.
- If the CONT. mode is selected the unit will continue to dehumidify and will not be controlled to a specific humidity setting.
- The humidity setting cannot be adjusted.
- To adjust the humidity setting, press the CONT. button to cancel the continuous mode.



TURBO button

TURBO

- The Turbo button is to toggle between normal fan speed and the highest fan speed (Turbo).
- Press to select either High or Normal fan speed.
- Set the unit to turbo by pressing the TURBO button (green light illuminated) for maximum moisture removal.
- When the desired humidity level has been reached, press the TURBO button once more (green line will extinguish) to return to normal operation.



TIMER button

TIMER

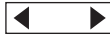
Timer button is used in conjunction with the  (Humidity Control) buttons to initiate the Auto start and Auto stop feature.

- On
- Off

Setting the Timer





TIMER

- The TIMER button can be used to set a desired ON or OFF time for the dehumidifier. The ON time or OFF time setting can only be set in increments of 0.5 hr. up to 10 hrs. and 1hr increments from 10 to 24 hrs.

Note:

- If the unit is off, the timer "On" indicator be the first to illuminate.
- If the dehumidifier is on, the timer "Off" indicator will first illuminate.
- Toggle between Timer On and Timer Off by pressing the TIMER button.

- Press the TIMER button, the timer Off or On indicator light illuminates. This indicates the auto stop/start program is initiated.
- Press or hold the  or  button to change the desired stop/start time by 0.5 hour increments, up to 10 hours, then at 1 hour increments from 10 to 24 hours from the time the feature is set. The control will count down the time remaining until the dehumidifier stops/starts

- Press the TIMER button again the timer On indicator light illuminates. This indicates the auto start program is initiated.
- Press or hold the ◀ or ▶ button to change the desired start time by 0.5hour increments, up to 10 hours, then at 1 hour increments from 10 to 24 hours from the time the feature is set. The control will count down the time remaining until starts.
- When the Timer On & Timer Off times are set, within the same program sequence, both On and Off indicator lights will illuminate indicating both On and Off times are programmed.
- Turning the unit On or Off at any time or adjusting the timer setting to 0.0 will cancel the Auto Start/Stop function.
- If the water bucket is full and the LED display window displays P2, the Auto Start/Stop function will also be canceled.

◀ ▶ Humidity Set Control Left/Right (buttons) _____

- The humidity set control buttons are used to set the desired humidity level.
- The humidity level can be set between 35% RH (Relative Humidity) to 85% RH (Relative Humidity) in 5% increments.
- For drier air, press the ◀ button to the desired lower RH % level.
- For more humid air, press the ▶ button to the desired higher RH% level.

POWER button _____ POWER

- Press to turn the dehumidifier on and off

OPTIONAL FEATURES (Only available on SOME Models)

PUMP button (on some models) _____ PUMP

- Press to activate the pump operation.



Note: Make sure the pump drain hose is installed into the unit and the continuous drain hose is disconnected from the unit before the pump operation is activated. When the bucket is full, the pump will start to operate.

- Refer to the next pages for removing the bucket and discarding the collected water.
- Do not use this operation when the outdoor temperature is at or below 32°F (0°C)

LED Display _____

Depending on the feature selected, the LED Display will show the current relative humidity level in the room (35% - 85%), the auto start/stop setting (0.0~24) while setting the timer function, as well as the desired humidity level setting for the dehumidifier. The accuracy of the relative humidity reading in the room is ±5% for humidity levels between 30% and 90%

OTHER FEATURES

○ FULL **Bucket Full Light**

The Full indicator light will be illuminated when the bucket is full and ready to be emptied or if the bucket was not put back in place correctly.

○ AUTO DEFROST **Auto Defrost**

The unit will automatically enter auto defrost mode when frost/ice builds up on the evaporator coils. The compressor will cycle off and the fan will continue to run until the frost disappears. During this operation the Auto Defrost indicator light will be illuminated.

Auto Shut Off

The dehumidifier shuts off when the bucket is full or when the bucket is removed or is not replaced in the proper position. The compressor will also automatically shut off when the desired humidity level is reached. The fan will continue to operate for an additional 3 minutes.

Auto-Restart

In the event of an unexpected power interruption, the unit will automatically restart with the previous function setting once the power is restored.

REMOVING THE COLLECTED WATER

There are three ways to remove collected water:

1

Using the bucket

- If the unit is off, and the bucket is full, the Full indicator light will illuminate
- If the unit is on and the bucket is full, the compressor and the fan will turn off, the Full indicator light will light will illuminate and the LED display will show P2.
- Slowly pull out the bucket. Grip the left and right handles securely, and carefully pull out straight so water does not spill. Do not put the bucket on the floor because the bottom of the bucket is uneven and the water may spill.
- Throw away the water and replace the bucket.
- The bucket must be replaced correctly and securely seated for the dehumidifier to operate
- The machine will re-start when the bucket is returned to its correct position.

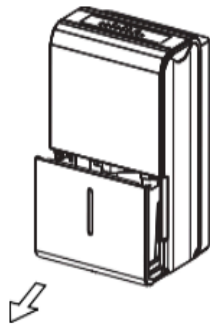

Fig. 6

1. Partially remove the bucket



Fig. 7

2. Hold both sides of the bucket with even strength, and completely remove from the unit and pour out the water

NOTE:

- When you remove the bucket, do not touch any parts inside the unit. Doing so may damage the product.
- Be sure to push the bucket gently all the way into the unit. Banging the bucket against anything or failing to push it in securely may cause the unit not to operate.
- If the pump hose drops when you remove the bucket, you must reinstall the pump hose properly to the unit before replacing the bucket into the unit.
- If there is some water in the unit after you remove the unit after you remove the bucket, you must dry it.
- If the bucket is removed while the unit is running, the compressor and the fan will turn off, the unit will beep 8 times and the digital display will show P2.
- If the bucket is removed while the unit is turn off, the unit will beep 8 times and the digital display will show P2.

2

Continuous draining

- Water can be automatically emptied into a floor drain by attaching a drain hose (ID \geq Φ 5/16", not included) with a female threaded end (ID:M=1", not included) to the drain outlet at the back of the dehumidifier (See Fig. 8)
- Remove the plastic cover from the continuous drain outlet at the back of the unit and set it aside.
- Connect the drain hose to the drain outlet of the unit and lead the drain hose to the floor drain or a suitable drainage facility (See Fig. 9)
- Make sure the hose is secure and there are not leaks or kinks that will stop the water from flowing
- Make sure the hose is angled down or level to allow for good flow of water towards the outlet.
- Select the desired dehumidifier setting, humidity level and fan speed

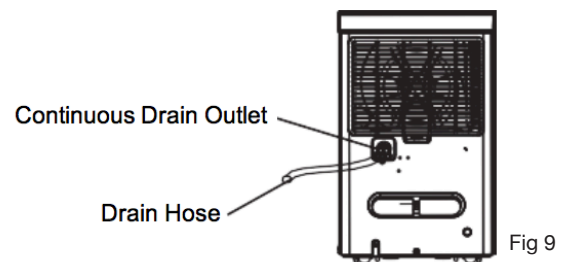
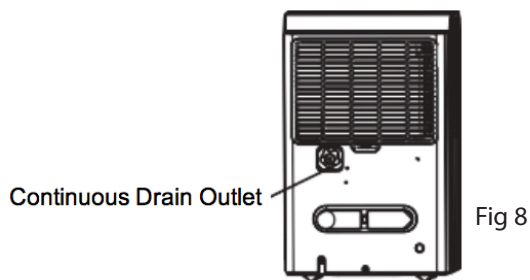

3

Pump draining (on some models)

- Water can be automatically emptied into a floor drain or a suitable drainage facility by connecting the pump drain hose (Φ OD=1/4", supplied) with the pump drain outlet as shown in Fig. 12 and using the pump feature on the dehumidifier.
- If a continuous drain hose is being used, remove it from the unit and reinstall the plastic cover to the continuous drain outlet.
- Connect the supplied pump drain hose onto the pump drain hose outlet (See Fig 12.)
- Make sure the hose is pushed on to the pump drain outlet to a depth of at least 1/2 inch (approx. 15 mm).
- Direct the drain hose outlet to a floor drain or a suitable drainage facility.
- Press the PUMP button on the control panel to start the pump operation
- The pump will start when the bucket is full

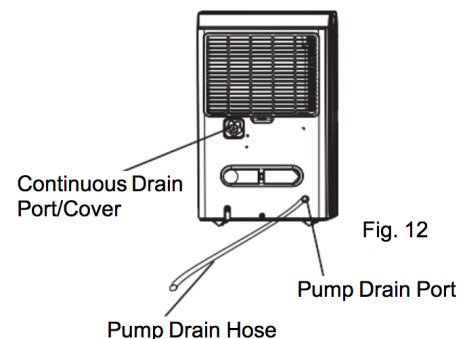
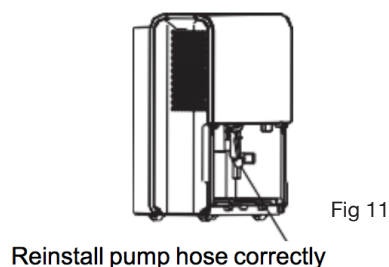
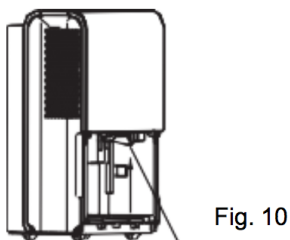

**Note:**

The pump may make a noticeable sound for 3~5 minutes on startup. It is a normal phenomenon.

**Note:**

The pump operation light will blink will at 1Hz if there is an operational failure of the pump. Please turn off the unit and unplug the power.

Check the following things:

- Clean pump filte
- Remove the bucket from the unit, take down the pump and clean the pump filte .
- Check that the pump drain hose is not kinked or blocked.
- Empty the water of the bucket.
- Reinstall the pump hose if it is disconnected from the unit and properly reinstall the bucket.
- Turn on the unit. If the error repeats, call for service.



Note: Do not use this operation when the outdoor temperature is equal to or less than 0 °C (32°F), otherwise water will freeze inside the hose resulting in unit failure.

- Empty the bucket once a week when using the pump drain feature.
- When the pump drain feature is not being used, remove the pump drain hose from the outlet.
- Press the pump drain hose outlet in towards the unit and pull the drain hose out (See Fig.13).
- Be careful to prevent water from leaking onto the floo .

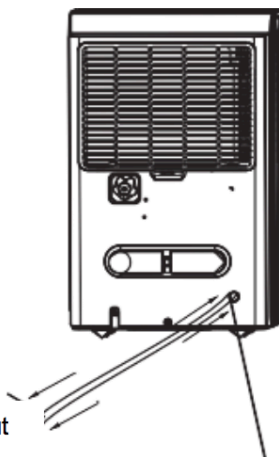

Fig. 13

Pull the pump drain hose out

Press the pump drain hose outlet in

CARE AND MAINTENANCE

Turn the dehumidifier off and unplug it from the wall outlet before cleaning.

- Use water and a mild detergent. Do not use bleach or abrasives.
- Do not splash water directly onto the main unit. Doing so may cause an electrical shock, cause the insulation to deteriorate, or cause the unit to rust.
- The air intake and outlet grilles get soiled easily; use a vacuum attachment or brush to clean.



Note:

Do not use a dishwasher to clean the bucket. After cleaning, the bucket must be replaced and securely seated for the dehumidifier to operate.

- Every few weeks, clean the bucket to prevent growth of mold, mildew and bacteria.
- Partially fill the bucket with clean water and add a little mild detergent.
- Swish it around in the bucket.
- Empty and rinse.

Cleaning the air filter

- The filter is integrated with the back panel of the unit and is not a separate item
- Remove the filter every two weeks based on normal operating conditions
- To remove the filter, pull filter outwards (See Fig. 14).
- Wash the filter with clean water then dry.
- Re-install the filter, replace Bucket.

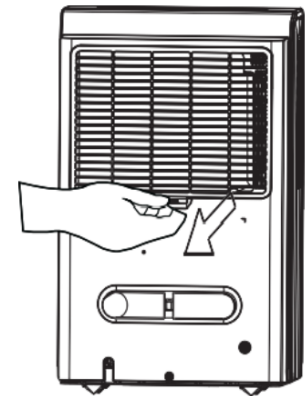

CAUTION

Do not operate the dehumidifier without a filter because dirt and lint will clog it and reduce performance

PREPARING FOR STORAGE

When not using the unit for long time periods

- After turning off the unit, wait one day before emptying the bucket.
- Clean the main unit, water bucket and air filter.
- Wrap the cord with onto the power cord handle
- Cover the unit with a plastic bag.
- Store the unit upright in a dry, well-ventilated place.

TROUBLESHOOTING TIPS

Before calling for service, review the chart below.

Problem	What to check
Unit does not start	<ul style="list-style-type: none"> • Make sure the dehumidifier's plug is pushed completely into the outlet. • Check the house fuse/circuit breaker box. • Dehumidifier has reached its preset level or bucket is full. • Water bucket is not in the proper position.
Dehumidifier does not dry the air as it should	<ul style="list-style-type: none"> • Did not allow enough time to remove the moisture. • Make sure there are no curtains, blinds or furniture blocking the front or back of the dehumidifier. • The humidity control may not be set low enough. • Check that all doors, windows and other openings are securely closed. • Room temperature is too low, below 5 °C(41 °F). • There is a kerosene heater or something giving off water vapor in the room.
The unit makes a loud noise when operating	<ul style="list-style-type: none"> • The air filter is clogged • The unit is tilted instead of upright as it should be. • The floor surface is not level
Frost appears on the coils	<ul style="list-style-type: none"> • This is normal. The dehumidifier has Auto defrost feature.
Water on floor	<ul style="list-style-type: none"> • Hose to connector or hose connection may be loose. • Intend to use the bucket to collect water, but the back drain plug is removed.
The pump operation on light blinks at 1Hz	<ul style="list-style-type: none"> • Clean the filter of the pump • Check the pump hose does not link or block. • Empty the water of the bucket.
ES- Tube Temperature sensor of the evaporator error	<ul style="list-style-type: none"> • Unplug the unit and plug it back in. If error repeats, call for service.
AS-Humidity sensor error	<ul style="list-style-type: none"> • Unplug the unit and plug it back in. If error repeats, call for service.
P2-Bucket is full or bucket is not in right position	<ul style="list-style-type: none"> • Empty the bucket and replace it in the right position
Eb-Bucket is removed or not in right position	<ul style="list-style-type: none"> • Replace the bucket in the right position.

The design and specifications are subject to change without prior notice. Consult with the sales agency or manufacturer for details. Any updates to the manual will be uploaded to the service website, please check for the latest version.



Perfect Aire, LLC
5401 Dansher Road
Countryside, IL 60625

1020_M398

844-4PA-AIRE | 844-472-2473
www.perfectaire.us

Printed in China