

# Razor®

## *dirt rocket*™

### SX500, MX500 and MX650



## OWNER'S MANUAL

**Read and understand this entire manual before allowing child to use this product! For assistance contact Razor.  
DO NOT RETURN TO STORE.**

**NOTE: Manual illustrations are for demonstration purposes only.  
Illustrations may not reflect exact appearance of actual product.  
Specifications subject to change without notice.**

**Please have your product along with the 19 character product I.D. code with you  
before contacting Razor for warranty assistance and/or replacement parts.**

**Product I.D. Code: \_\_\_\_\_ - \_\_\_\_\_ - \_\_\_\_\_**





# CONTENTS

Safety Warnings.....	1-2	Usage.....	7
Before You Begin.....	3	Repair and Maintenance.....	7-12
Assembly and Set-Up.....	4-5	Troubleshooting Guide.....	13-14
Charging the Battery.....	6	Product Parts.....	15
Pre-Ride Checklist.....	6	Warranty and Contact Information.....	17

# SAFETY WARNINGS

**⚠ WARNING:** Riding an electric motor bike does present potential risks and caution is required. Like any riding product, an electric motor bike has inherent hazards associated with its use (for example, falling off or riding it into a hazardous situation). Like any riding product, electric motor bikes can and are intended to move and it is therefore, of course, possible to lose control or otherwise get into dangerous situations. Both children, and adults responsible for supervising them, must recognize that if such things occur, a rider can be seriously injured or die even when using safety equipment and other precautions. **RIDE AT YOUR OWN RISK AND USE COMMON SENSE.**

**⚠ WARNING: PARENTAL AND ADULT RESPONSIBILITY AND SUPERVISION NECESSARY:** This manual contains important safety information. It is your responsibility to review this information and make sure that all riders understand all warnings, cautions, instructions and safety topics, and assure that young riders are able to safely and responsibly use these products. Razor recommends that you periodically review and reinforce the information in this manual with younger riders, and that you inspect and maintain your children's product to ensure their safety.

**⚠ WARNING: THE SX500/MX500 IS NOT FOR CHILDREN UNDER AGE 14 OR HEAVIER THAN 175 LB (79 KG). THE MX650 IS NOT FOR CHILDREN UNDER AGE 16 OR HEAVIER THAN 220 LB (100 KG).** Because products, like electric motor bikes, can and do present potential hazards plainly associated with their use, it is well recognized THE NEED FOR EXERCISE OF PARENTAL RESPONSIBILITY IN SELECTING RIDING PRODUCTS APPROPRIATE TO THE AGE OF A CHILD, OR PARENTAL SUPERVISION IN SITUATIONS IN WHICH CHILDREN OF VARIOUS AGES MAY HAVE ACCESS TO THE SAME RIDING PRODUCTS, IS IMPORTANT. Not every product is appropriate for every age or size of child, and different age recommendations are found within this category of product which are intended to reflect the nature of the hazards and the expected mental or physical ability, or both, of a rider to cope with the hazards.

Razor recommends that children under the age of 14 not be permitted to use the SX500/MX500 and that children under the age of 16 not be permitted to use the MX650. This recommendation is based not just on age or weight or height – it reflects consideration of expected maturity and skills as well as physical size. The recommended rider age of 14 years or older for SX500/MX500 and rider age of 16 years or older for MX650 are only estimates and can be affected by the rider's size, weight or skills – not every child 14 years old will be suited to the SX500/MX500 and not every child 16 years old will be suited to the MX650. Certainly, any rider unable to fit comfortably on the SX500/MX500/MX650 should not attempt to ride it, but a **parent's decision to allow his or her child to ride these products should be based on the child's maturity, skill, and ability to follow rules. Razor emphasizes that adults are strongly advised not to disregard Razor's recommendations or permit younger children to ride the SX500/MX500/MX650.**

**DO NOT EXCEED THE WEIGHT LIMIT OF 175 lb (79 kg) for SX500/MX500 and 220 lb (100 kg) for MX650. Rider weight alone also does not necessarily mean a person's size is appropriate to fit or maintain control of the SX500/MX500/MX650.** Keep these products away from small children and remember that these products are intended for use only by persons who are, at a minimum, completely comfortable and competent while operating these products.

Persons with any mental or physical conditions that may make them susceptible to injury, impair their physical dexterity or mental capabilities to recognize, understand, and follow safety instructions and to be able to understand the hazards inherent in a product's use, should not use or be permitted to use products inappropriate for their abilities. Persons with heart conditions, head, back or neck ailments (or prior surgeries to these areas of the body), or pregnant women, should be cautioned not to operate these products.

## CHECK AND MAINTAIN MOTOR BIKE CONDITIONS

Before use, check to confirm that any and all chain guards or other covers and guards are in place and in serviceable condition. Check that the brakes are functioning properly, and that tires are inflated properly and have sufficient tread remaining. The motor bike should be maintained and repaired in accordance with the manufacturer's specifications, using only the manufacturer's authorized replacement parts, and should not be modified from the manufacturer's original design and configuration.

## ACCEPTABLE RIDING PRACTICES AND CONDITIONS

**Always check and obey any local laws or regulations, which may affect the locations where the electric motor bike may be used. Keep safely away from cars and motor vehicle traffic at all times, and only use where allowed and with caution.**

Do not activate the speed control on the hand grip unless you are on the motor bike and in a safe, outdoor environment suitable for riding.

The normal powered top speed of these motor bikes will be approximately 15 mph (24 km/h) for SX500/MX500 and 17 mph (27 km/h) for MX650, which can be affected by conditions, such as rider weight, inclines, tire inflation and battery charge level. Avoid excessive speeds that can be associated with downhill rides.

Maintain a hold on the handlebars at all times. Do not touch the brakes or motor on your motor bike when in use or immediately after riding, as these parts can become very hot.

Ride defensively. Watch out for potential obstacles that could catch your wheel or force you to swerve suddenly or lose control. Be careful to avoid pedestrians, skaters, skateboards, scooters, bikes, children or animals who may enter your path, and respect the rights and property of others.

These electric motor bikes are intended for use on flat, dry surfaces, such as pavement or level ground, without loose debris, such as sand, leaves, rocks or gravel. Wet, slick, bumpy, uneven or rough surfaces may impair traction and contribute to possible accidents. Do not ride your motor bike in mud, ice, puddles or water. Watch out for potential obstacles that could catch your wheel or force you to swerve suddenly or lose control. Avoid sharp bumps, drainage grates, and sudden surface changes.

Do not attempt or do stunts or tricks on your electric motor bike. These motor bikes are not made to withstand abuse from misuse, such as jumping, curb grinding or any other type of stunts. Racing, stunt riding, or other maneuvers also enhance risk of loss of control, or may cause uncontrolled rider actions or reactions.

# SAFETY WARNINGS

Never allow more than one person at a time to ride the motor bike.

Do not ride at night or when visibility is limited.

Never use near steps or swimming pools.

Do not allow hands, feet, hair, body parts, clothing, or similar articles to come in contact with moving parts, wheels, or drive train chain while the motor is running.

Never use headphones, a cell phone or text when riding.

Never hitch a ride with a vehicle.

Do not ride your motor bike in wet or icy weather and never immerse the motor bike in water, as the electrical and drive components could be damaged by water or create other possibly unsafe conditions. Never risk damaging surfaces, such as carpet or flooring, by use of an electric motor bike indoors.

## PROPER RIDING ATTIRE

Always wear proper protective equipment, such as an approved safety helmet (with chin strap securely buckled), elbow pads and kneepads.

A helmet may be legally required by local law or regulation in your area.

A long-sleeved shirt, long pants, and gloves are recommended. Always wear athletic shoes (lace-up shoes with rubber soles) and keep shoelaces tied and out of the way of the wheels, motor and drive system. Never ride barefooted or in sandals.

## USING THE CHARGER

The charger supplied with the electric motor bike should be regularly examined for damage to the cord, plug, enclosure and other parts. In the event of such damage, the motor bike must not be charged until the charger has been repaired or replaced.

Use only with the recommended charger.

Use caution when charging.

The charger is not a toy. Charger should be operated by an adult.

Do not operate charger near flammable materials.

Unplug charger and disconnect from motor bike when not in use.

Always disconnect from the charger prior to wiping down and cleaning your motor bike with damp cloth.

**FAILURE TO USE COMMON SENSE AND HEED THE ABOVE WARNINGS INCREASES RISK OF SERIOUS INJURY. USE WITH APPROPRIATE CAUTION AND SERIOUS ATTENTION TO SAFE OPERATION.**

---

**Need Help?** Visit our website for replacement parts, product support, a list of authorized service centers in the US and customer service contact information at [www.razor.com](http://www.razor.com). Please have the product I.D. code (located on the white label of your product) available for better assistance. Additional Customer Service contact information is listed at the back of this manual.

# BEFORE YOU BEGIN

Remove contents from box. Remove the separators that protect the components from damage during shipping. Inspect the contents of the box for scratches in the paint, dents or kinked cables that may have occurred during shipping. Because the motor bike was 95 percent assembled and packed at the factory, there should not be any problems, even if the box has a few scars or dents.

**MAKE SURE POWER SWITCH IS TURNED "OFF" BEFORE CONDUCTING ANY ASSEMBLY OR MAINTENANCE PROCEDURES.**

## Estimated Assembly and Set-Up Time

Razor recommends assembly by an adult with experience in bicycle mechanics. Allow up to 30 minutes for assembly, not including initial charge time. Allow up to 12 hours for charge (see page 6 for charging information).

Charger  
(Note: Charger design may vary from one shown)

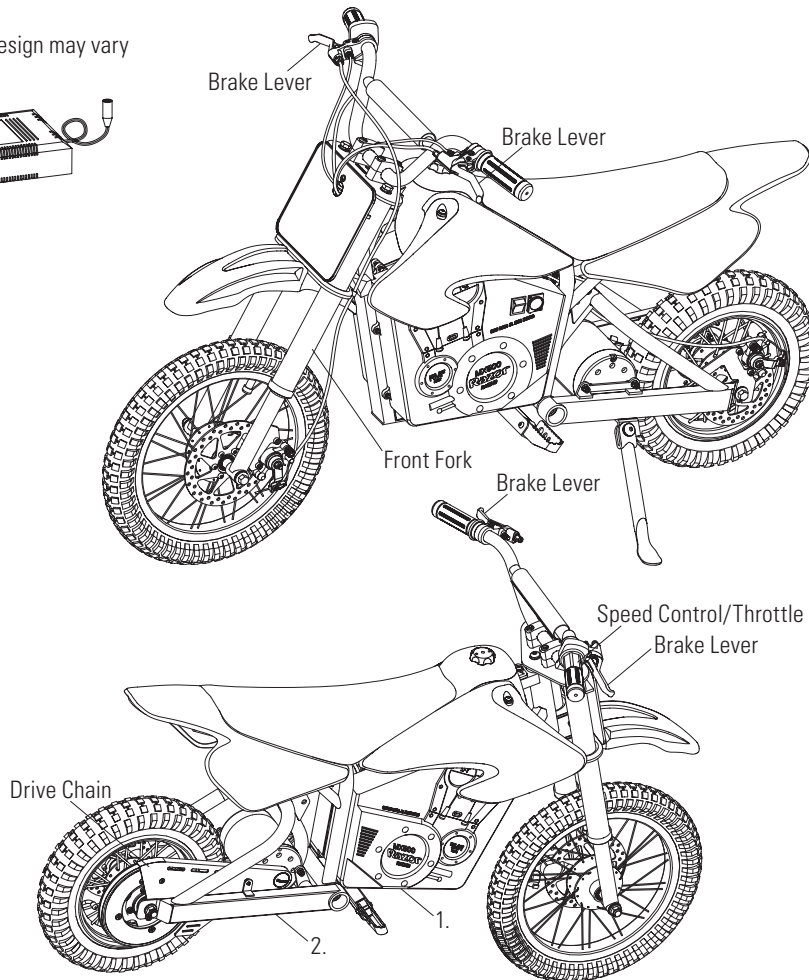
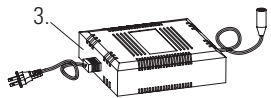

## WARNING:

**DO NOT USE NON-RAZOR PRODUCTS WITH YOUR RAZOR ELECTRIC MOTOR BIKE.** The motor bike has been built to certain Razor design specifications. The original equipment supplied at the time of sale was selected on the basis of its compatibility with the frame, fork and all other parts. Certain aftermarket products may not be compatible and will void the warranty.

## Product ID Locations:

(See locations to the left)

1. Battery cover
2. Frame (underneath unit)
3. Charger
4. Box - side of UPC (not shown)

## Required Tools

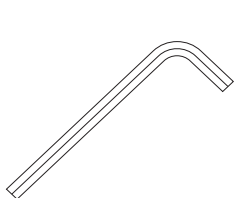

5 mm and 6 mm Allen wrenches (Included)

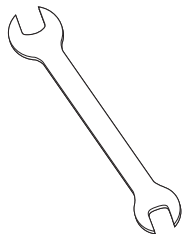

10 mm, 14 mm and 17 mm wrenches (Included)  
**(MX500/MX650 Models)**

10 mm, 17mm and 19 mm wrenches (included)  
**(SX500 Model)**

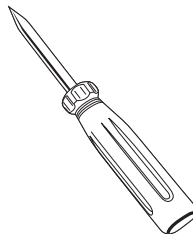

Phillips screwdriver (Included)

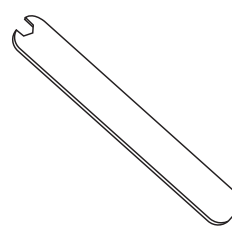

Spoke tightener (Included)

## Plastic Bag Contents:

- Charger
- Handlebar Clamps
- Front Axle Bolt
- Tools
- Owner's Manual



# ASSEMBLY AND SET-UP

## □ Attaching the Handlebars

**Required Tools:** 6 mm Allen Wrench and 5 mm Allen Wrench (included)

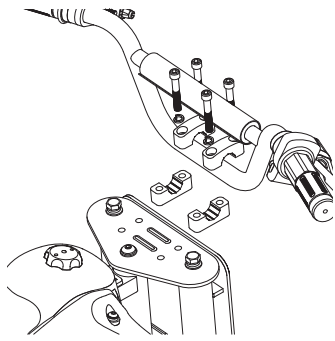

**1** Place the handlebars in the handlebar clamps.

**Note:** Handlebar clamps are located in the plastic bag.

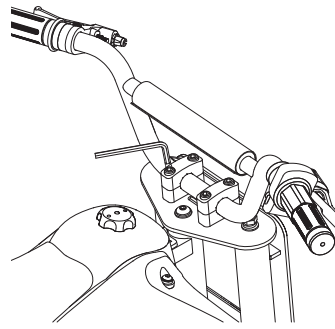

**2** Align handlebars parallel to the fork and tighten the bolts using a 6 mm Allen wrench. When properly tightened, the handlebars should not move forward or backward.

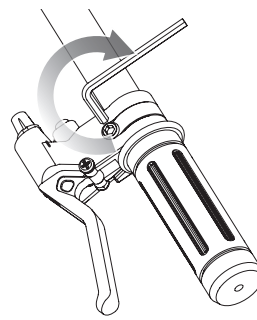

**3** Adjust the brake lever adjuster to the proper place and tighten it with the 5 mm Allen wrench.

### **⚠ WARNING:**

Failing to properly adjust and tighten the bolts that affix the handlebars can cause you to lose control and crash.

## □ Attaching the Front Fender

**Required Tools:** 10 mm Wrench and 5 mm Allen Wrench (included)

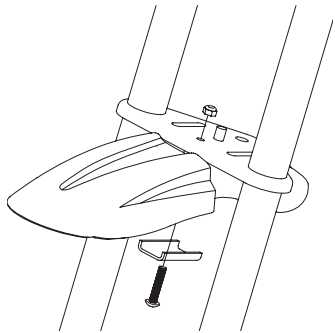

Align fender with the hole in the fork and insert the bolt. Tighten securely using a 10 mm wrench and 5 mm Allen wrench.

**Note:** Front fender design may vary.

## □ Attaching the Number Plate

**Required Tools:** Phillips Screwdriver (included)

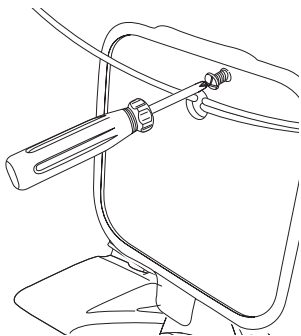

### **MX500/MX650 Models**

Remove screw from front fork. Align the number plate with the hole in the fork and tighten with a Phillips screwdriver.

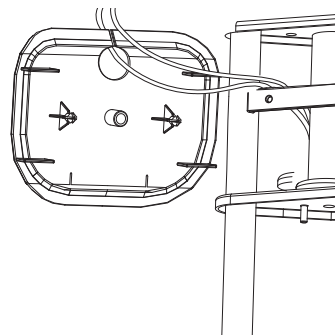

### **SX500 Model**

Slip the cables through the slit on the top of the number plate. Align the number plate with the holes on the fork and snap on the number plate.

**Need Help?** Visit our website for replacement parts, product support, a list of authorized service centers in the US and customer service contact information at [www.razor.com](http://www.razor.com). Please have the product I.D. code (located on the white label of your product) available for better assistance. Additional Customer Service contact information is listed at the back of this manual.

# ASSEMBLY AND SET-UP

## □ Installing the Front Wheel

**Required Tools:** 14 mm Wrench and 17 mm Wrench (**MX500/MX650 Models**) (included)  
17 mm Wrench and 19 mm Wrench (**SX500 Model**) (included)

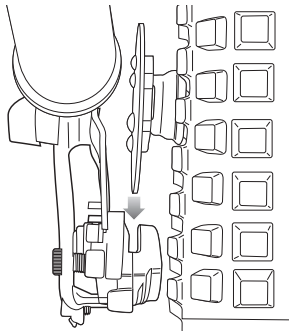

**1** Position wheel in front fork and slide disc brake into caliper.

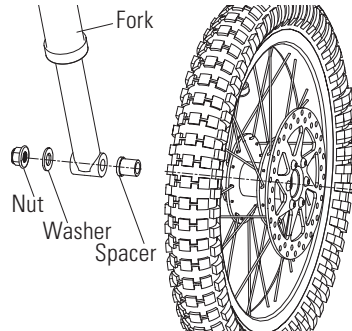

**2** Slide axle through fork, spacer and wheel hub. When axle passes through the other side of the wheel hub, add the other spacer, and slide through the fork. Secure with washer and nut.

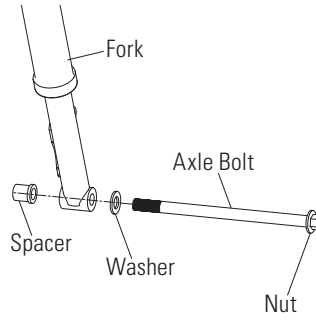

**Note:** Front axle is installed with the spacer between the fork and wheel for all Dirt Rockets.



### MX500/MX650 Models

**3** With a 14 mm and 17 mm wrench, tighten the front wheel.

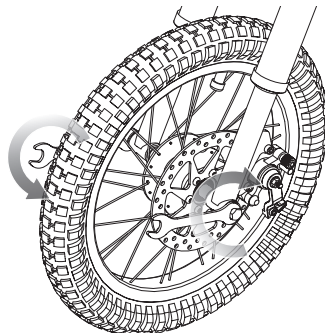

### SX500 Model

**3** With a 17 mm and 19 mm wrench, tighten the front wheel.

## □ Inflating the Tires

Tires are inflated when shipped, but they invariably may lose some pressure between the point of manufacturing and your purchase. **Always inflate tires to the correct PSI before first time use.**

Lower air pressure can result in a shorter ride time. Periodically check tires. Reinflate when needed.

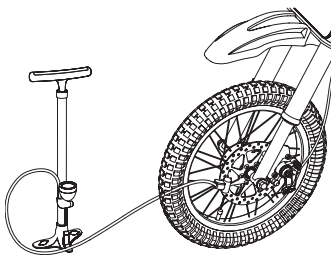

**1** Using a bicycle-style tire pump equipped for a Schrader-type valve, inflate the tires to the correct PSI indicated on the sidewall of the tires.

**⚠ WARNING:** Failing to properly adjust and tighten the nuts and bolts that affix the fork can cause you to lose control and fall.

**⚠ WARNING:** Do not use the electric motor bike for the first time until you have inflated the tires to the correct PSI. Failure to do so may damage your electric motor bike and void your warranty.

**⚠ WARNING:** Do not overinflate, as this could damage tire or wheel.

**Note:** The pressurized air supplies found at gasoline stations are designed to inflate high-volume automobile tires. If you decide to use such an air supply to inflate your motor bike tires, first make sure the pressure gauge is working, then use very short bursts to inflate to the correct PSI. If you inadvertently over-inflate the tire, release the excess pressure immediately.

**Need Help?** Visit our website for replacement parts, product support, a list of authorized service centers in the US and customer service contact information at [www.razor.com](http://www.razor.com). Please have the product I.D. code (located on the white label of your product) available for better assistance. Additional Customer Service contact information is listed at the back of this manual.



# CHARGING THE BATTERY

**Your electric motor bike may not have a fully charged battery; therefore you must charge the battery prior to use.**

- Initial charge time: 12 hours.
- Recharge time: up to 12 hours, even if the light turns green. Recommended maximum charging time is 24 hours.
- Always charge the battery immediately after riding.
- Fully charge battery before storing for extended periods of time.
- Unplug charger from the wall outlet when not in use.
- Failure to recharge battery periodically may result in a battery that will not accept a charge.
- Make sure the power switch is turned **OFF** when unit is not in use. If the power switch is left on for an extended period of time, the battery may reach a stage at which it will no longer hold a charge.
- To ensure long battery life, never store the product in freezing or below freezing temperatures! Freezing will permanently damage the battery.
- Run time: Up to 40 minutes of continuous ride time. Run time may vary depending on riding conditions, rider weight, climate, and/or proper maintenance.
- Battery life can vary depending on proper maintenance and usage of the unit.

Charger

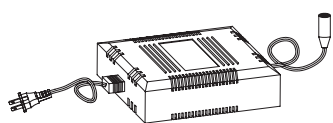

Charger

(Note: Charger design may vary from one shown)

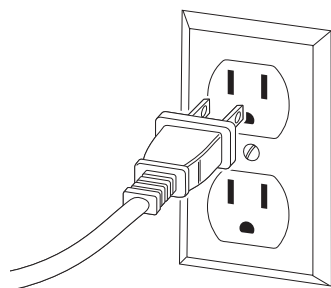

**1** Plug the charger plug into wall outlet. The light on the charger should be green.

**Note:** If green light (LED) does not turn on, try a different outlet.

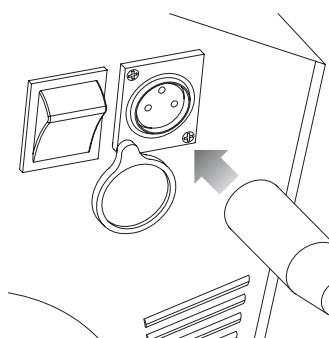

**2 Note:** Make sure power button is in the **OFF** position. Plug the charger into the charger port. The light on the charger should turn red during charging. The light will turn green again when charging is complete.

**⚠ WARNING:** Use **ONLY** with the recommended charger. Batteries are only to be charged under adult supervision. The charger is not a toy. Always disconnect the charger before wiping down and/or cleaning the motor bike with a damp cloth.

The charger supplied with the motor bike should be regularly examined for damage to the cord, plug, enclosure and other parts. In the event of such damage, the electric motor bike must not be charged until it has been repaired or replaced.

Chargers have built-in overcharge protection to prevent battery from being overcharged.

**Note:** If the charger gets warm during regular use, this is a normal response and is no cause for concern. If your charger does not get warm during use, it does not mean that it is not working properly.

Wall outlet - Green (stand by)  
Wall outlet and unit - Red (charging)  
Wall outlet and unit - Green (charged)

**Note:** Continue charging unit even if light turns green prior to 12 hours.

**⚠ WARNING:** Failure to recharge the battery at least once a month may result in a battery that will no longer accept a charge.

# PRE-RIDE CHECKLIST



## Brake

Check the brakes for proper function. When you squeeze the brake levers, the brakes should provide positive braking action. Make sure that brakes are not rubbing when the brake levers are released.



## Tires

Periodically inspect the tires for excess wear and replace as needed. Regularly check the tire pressure and inflate as needed. If you get a flat tire, the inner tube can be patched or a new tube can be purchased from Razor or an authorized repair center.



## Frame, Fork and Handlebars

Check for cracks or broken connections. Although broken frames are rare, it is possible for an aggressive rider to run into a curb or object, and wreck and bend or break a frame. Get in the habit of inspecting your electric motor bike on a regular basis.



## Hardware/Loose Parts

Before every ride, check all parts, such as nuts, bolts, cables, fasteners, etc., to ensure they are secure and assembled correctly. There should not be any unusual rattles or sounds from loose parts or broken components. If the unit is damaged, do not ride. **Reference "Safety Warnings" on pages 1 and 2 of this manual.**



## Safety Gear

Always wear proper protective gear, such as an approved safety helmet. Elbow pads and kneepads are recommended. Always wear athletic shoes (lace-up shoes with rubber soles) and keep shoelaces tied and out of the way of the wheels, motor and drive system. **NEVER RIDE BAREFOOTED OR IN SANDALS.**



## Laws and Regulations

Always check and obey any local laws or regulations.



## Insurance

Do not assume that your existing insurance policies necessarily provide coverage for motor bike use. Check with your insurance company for information regarding insurance.



## Storage

Prolonged exposure to UV rays, rain and the elements may damage the enclosure materials, store indoors when not in use.

## USAGE

### □ Starting the Electric Product

Place both hands on the handlebars. Slowly push forward with one foot and apply the throttle (A).

**Note:** Keep both feet on the foot pegs when unit is in motion.

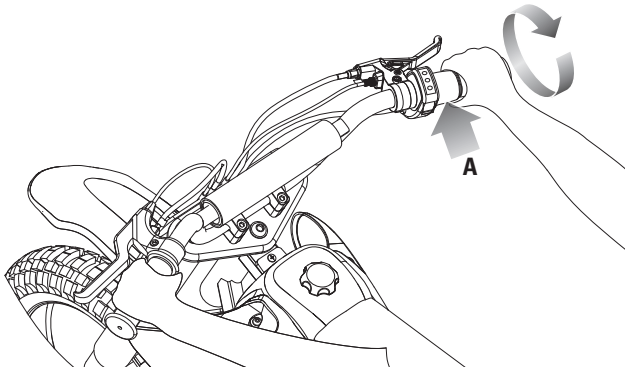

### □ Stopping the Electric Product

Release the throttle (A) and apply the brakes, by squeezing the brake levers (B & C).

**Note:** When coming to a complete stop, place both feet on the ground to balance the unit.

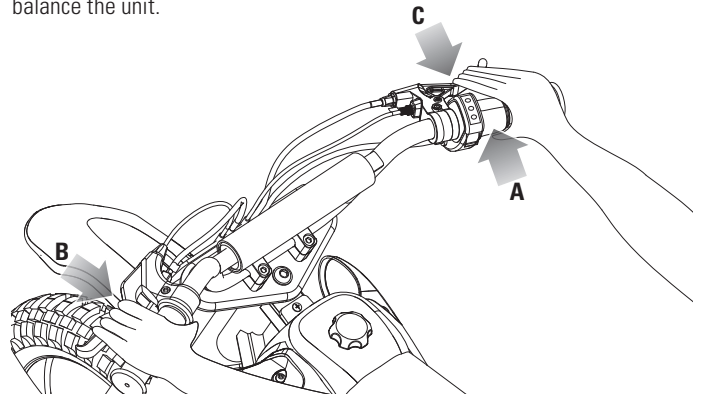

## REPAIR AND MAINTENANCE

### Turn power switch "OFF" before beginning repair or maintenance:

- Read the instructions
- Remove charger plug
- Turn the power switch off
- Secure the unit under repair
- Exercise caution around exposed parts
- Contact Razor customer service if unsure about any repair or maintenance

### □ Adjusting the Brakes

**Required Tools:** 5 mm Allen Wrench (included)

The brake lever is fitted with a cable adjuster to compensate for cable stretch and/or to fine tune the lever movement to brake engagement.

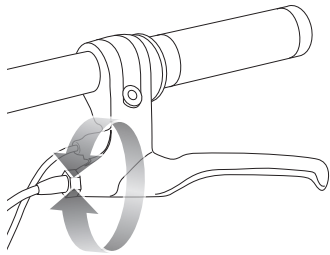

**1** To adjust brake cable play, thread the brake lever adjuster in or out 1/4 to 1/2 turn until the desired brake adjustment is attained. Most adjustments are complete at this step. If brake still needs further adjustment, proceed to step 2.

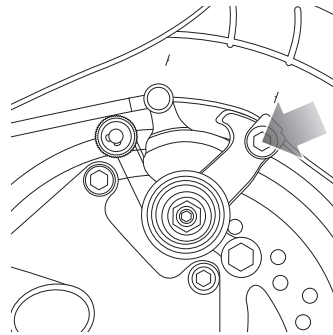

**2** If the brake has too much slack, loosen the rear anchor bolt with a 5 mm Allen wrench and pull the brake wire tighter. The distance of the brake wire between the end of the cable and the anchor bolt should be between 37 mm and 44 mm.

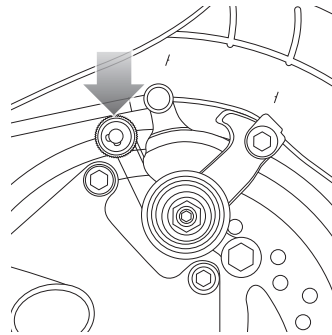

**3** If the brake rotor is dragging on the brake pads, use your fingers to twist the caliper adjuster in either direction until rotor is centered between pads.

**⚠ WARNING:** The brakes are capable of causing the electric motor bike to skid the tire throwing an unsuspecting rider. Practice in an open area free from obstacles until you are familiar with the brake function. Avoid skidding to a stop as this can cause you to lose control or damage the tires.

**Testing the Brakes.** To use the brakes, squeeze the brake levers to increase the pressure on the brakes. The brake levers are fitted with a cable adjuster to compensate for cable stretch and/or to fine-tune the lever movement to brake engagement. If brakes are not engaging properly, follow instructions for adjusting the brakes.

**Note:** The brake levers contain safety switches to cut power to the motor when the brakes are applied. In an emergency, applying the brakes will always stop the product from moving. Do not disable or replace these brake levers with anything other than genuine Razor replacement parts.

# REPAIR AND MAINTENANCE

## □ Replacing the Fuses

MX500/MX650

**Required Tools:** 4 mm Allen Wrench, 5 mm Allen Wrench, 10 mm Wrench, and Phillips Screwdriver (included)

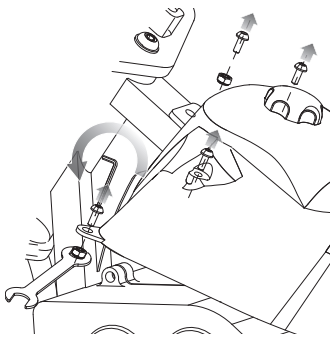

**1** Using a 5 mm Allen wrench and a 10 mm wrench remove the four (4) Allen bolts that hold the fairing in place. The two (2) screws at the bottom are held by 10 mm locknuts.

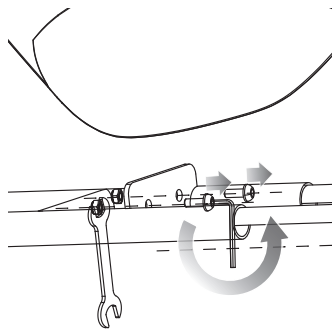

**2** Using a 5 mm Allen wrench and a 10 mm wrench remove the two (2) Allen bolts located underneath the rear of the seat. The two (2) screws are held by 10 mm locknuts.

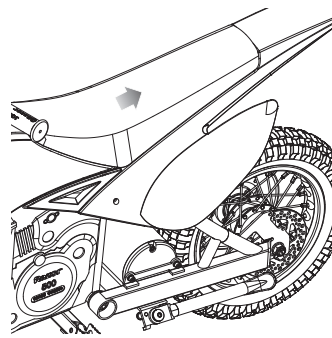

**3** Push the seat back and remove.

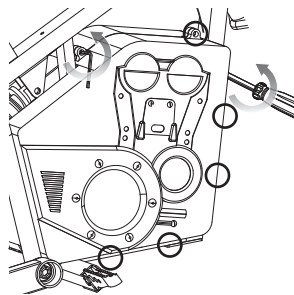

**4** Using a 4 mm Allen wrench locate and remove the two (2) bolts on top of the battery cover and using a Phillips screwdriver locate and remove the four (4) screws that attach the battery cover. Remove the battery cover and set aside.

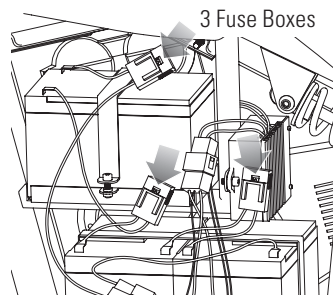

**5** Locate the three (3) fuse boxes attached to the batteries.

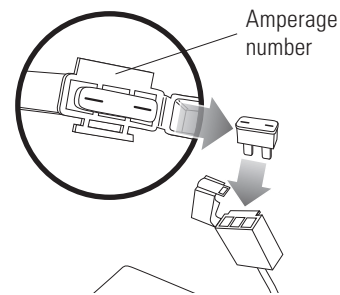

**6** Check all three (3) fuses to see if any fuses have burned out. Remove any fuse that is damaged or burned out and replace with a new one of equal amperage.

**Note:** Amperage is located on top of fuse.

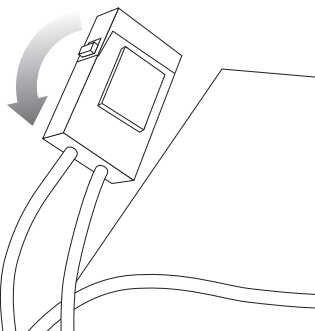

**7** Close the fuse cover.

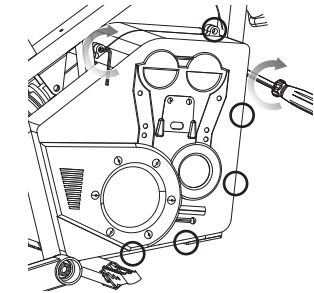

**8** Using a 4 mm Allen wrench reinstall the two (2) bolts on top of the battery cover and using a Phillips screwdriver reinstall the four (4) screws that attach the battery cover.

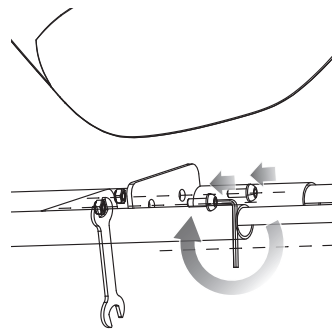

**9** Push the seat back on and using a 5 mm Allen wrench and a 10 mm wrench reinstall the two (2) Allen bolts located underneath the rear of the seat. The two (2) screws are held by 10 mm locknuts.

**⚠ WARNING:** To prevent shock, please follow the instructions accordingly and do not skip any steps.

**Need Help?** Visit our [www.razor.com](http://www.razor.com) for replacement parts, product support, a list of authorized service centers in the US and customer service contact information at [www.razor.com](http://www.razor.com). Please have the product I.D. code (located on the white label of your product) available for better assistance. Additional Customer Service contact information is listed at the back of this manual.

# REPAIR AND MAINTENANCE

## □ Replacing the Fuses (Continued)

MX500/MX650

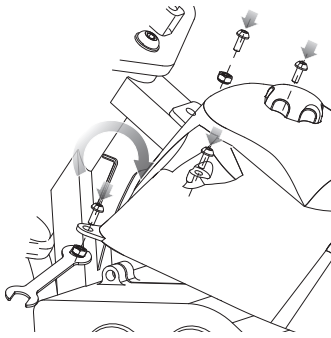

**10** Using a 5 mm Allen wrench and a 10 mm wrench reinstall the four (4) Allen bolts that hold the fairing in place. The two (2) screws at the bottom are held by 10 mm locknuts.

### SX500

**Required Tools:** 5 mm Allen Wrench and 4 mm Allen Wrench (included)

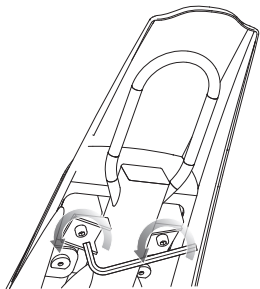

**1** Using a 5 mm Allen wrench remove the two (2) bolts from the underside of the back of the fairing.

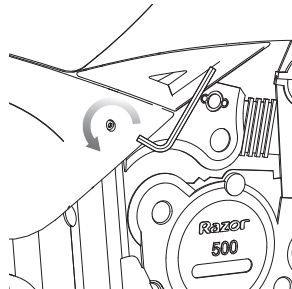

**2** Using a 4 mm Allen wrench remove the bolts located on each side of the unit and one more at the front next to the "tank."

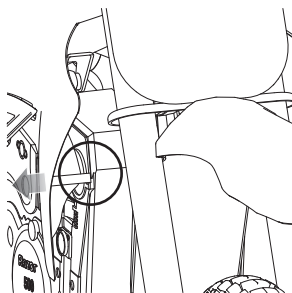
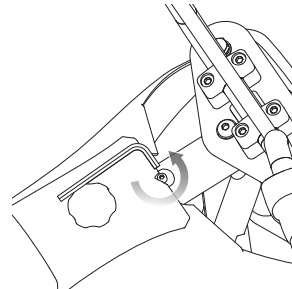

**3** Pull the left and right leafboards apart to remove the positioning column from the battery box and using a 4 mm Allen wrench remove the two (2) bolts from the top of the battery cover and three (3) more on each side and remove the covers.

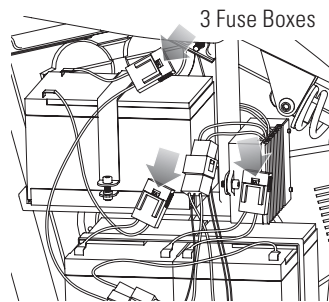
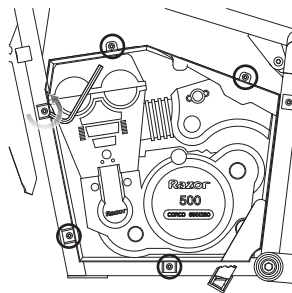

**4** Locate the three (3) fuse boxes attached to the batteries.

**⚠ WARNING:** To prevent shock, please follow the instructions accordingly and do not skip any steps.

**Need Help?** Visit our [www.razor.com](http://www.razor.com) for replacement parts, product support, a list of authorized service centers in the US and customer service contact information at [www.razor.com](http://www.razor.com). Please have the product I.D. code (located on the white label of your product) available for better assistance. Additional Customer Service contact information is listed at the back of this manual.



# REPAIR AND MAINTENANCE

## □ Replacing the Fuses (Continued)

SX500

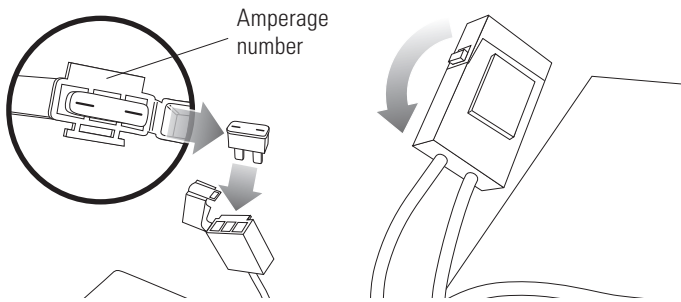

**5** Check all three (3) fuses to see if any fuses have burned out. Remove any fuse that is damaged or burned out and replace with a new one of equal amperage.

**6** Close the fuse cover.

**Note:** Amperage is located on top of fuse.

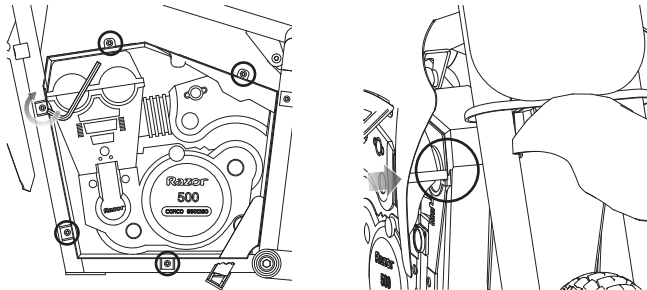

**7** Using a 4 mm Allen wrench reinstall the two (2) bolts to the top of the battery cover and three (3) more on each side and push the left and right leafboards together to reinstall the positioning column to the battery box and reinstall the covers.

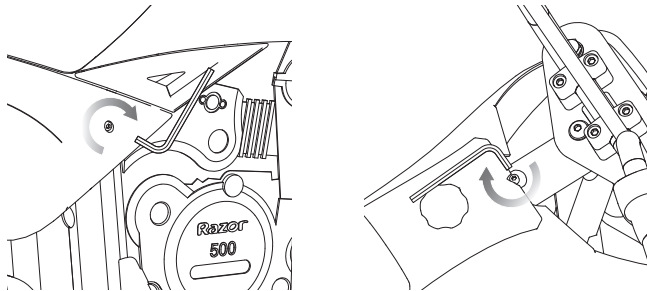

**8** Using a 4 mm Allen wrench reinstall the bolts located on each side of the unit and one more at the front next to the "tank."

**9** Using a 5 mm Allen wrench reinstall the two (2) bolts to the underside of the back of the fairing.

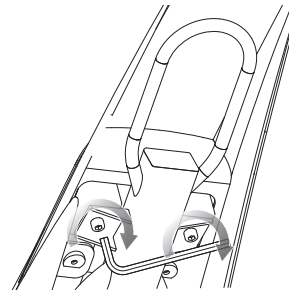



# REPAIR AND MAINTENANCE

## □ Replacing the Chain and Tire

**Required Tools:** Phillips Screwdriver and Two (2) 19 mm Wrenches (included)

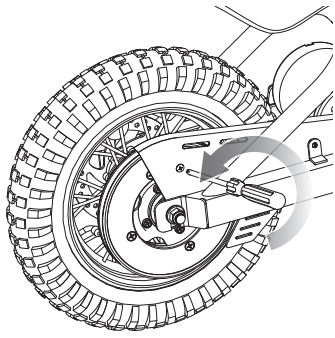

**1** Using a Phillips screwdriver loosen screws and remove chain guard.

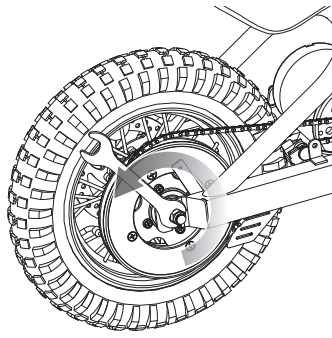

**2** Using two 19 mm wrenches, loosen both axle nuts.

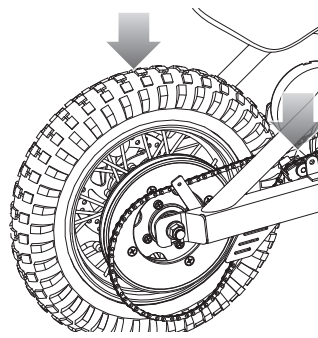

**3** Push the chain tensioner down to loosen the chain and remove the chain from the wheel sprocket and motor sprocket. Push and remove the wheel downward.

**Note:** Your hands will get greasy doing this.

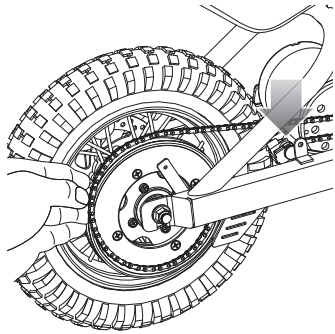

**4** Install the new chain or wheel by slipping the chain around the axle. Slide the axle into the slots on the frame. Slide the chain tensioner down and maneuver the chain onto the rear sprocket and motor sprocket.

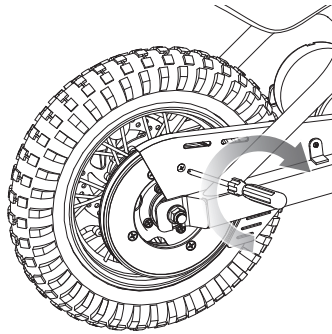

**5** Reattach the chain guard. Test ride and check. Readjust as needed.

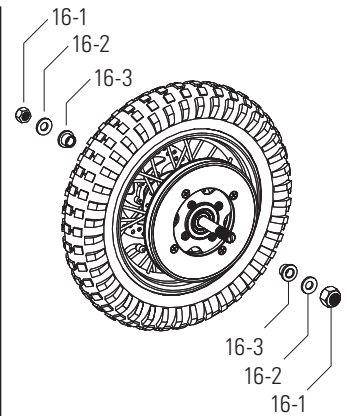

**Note:** the arrangement of the hardware sequence:

### Right Side (Throttle)

16-1 Nut  
16-2 Washer  
Frame  
16-3 Spacer

### Left Side (Brake)

16-1 Nut  
16-2 Washer  
Frame  
16-3 Spacer

**Need Help?** Visit our [www.razor.com](http://www.razor.com) for replacement parts, product support, a list of authorized service centers in the US and customer service contact information at [www.razor.com](http://www.razor.com). Please have the product I.D. code (located on the white label of your product) available for better assistance. Additional Customer Service contact information is listed at the back of this manual.

# REPAIR AND MAINTENANCE

## ☐ Spoke Tension

**Required Tool:** Spoke tightener (included)

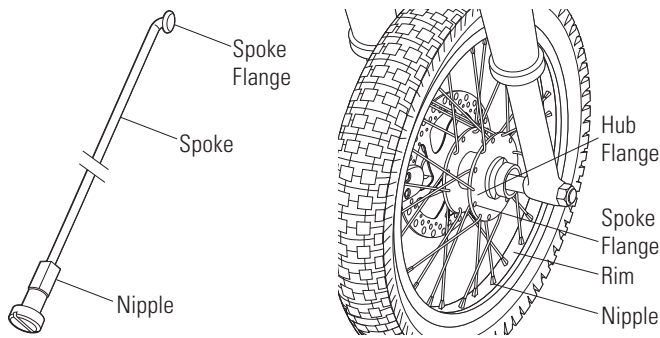

**1** Verify the spoke tension by shaking each spoke with your fingers. Spoke should not be loose from hub. Look for any play between where the spoke flanges attach to the hub. Try to turn the nipple using your fingers. You should not be able to spin any nipple by hand. If one or more spokes is loose, all spokes must be checked and need to be tightened with a spoke tightener.

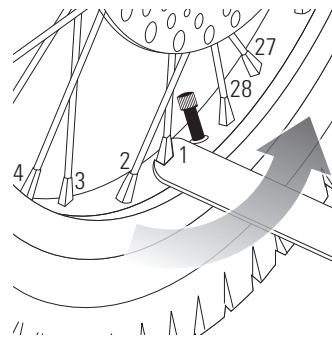

**2** Start with spoke closest to the tire valve stem and tighten each nipple, in sequence, exactly 1/4 to 1/2 turn. A single 1/4 to 1/2 turn may not be enough to bring the spokes into proper tension. Continue tightening all spokes, no more than 1/2 turn, in sequence until all spokes are tight.

**Note:** More than a 1/2 turn each can cause the wheel to become distorted and wobbly, thus permanently damaging the wheel.

## ☐ Chain and Sprocket

Proper chain alignment must be maintained. The wheel must not be skewed. If the chain is noisy or running rough, check the lubrication, tension and alignment of the sprockets, in that order.

## ☐ Battery Care and Disposal

Do not store in freezing or below temperatures. To properly maintain your battery and ensure maximum battery life, carefully read the "Charging the Battery" section on page 6 of this owner's manual.



CONTAINS SEALED NON-SPILLABLE LEAD-ACID BATTERIES. BATTERIES MUST BE RECYCLED.

**Disposal:** Your Razor product uses sealed lead-acid batteries which must be recycled or disposed of in an environmentally safe manner. Do not dispose of a lead-acid battery in a fire. The battery may explode or leak. Do not dispose of a lead-acid battery in your regular household trash. The incineration, land filling or mixing of sealed lead-acid batteries with household trash is prohibited by law in most areas. Return exhausted batteries to a federal or state approved lead-acid battery recycler or a local seller of automotive batteries. If you live in Florida or Minnesota, it is prohibited by law to throw away lead-acid batteries in the municipal waste stream.

## ☐ Charger

The charger supplied with the electric motor bike should be regularly examined for damage to the cord, plug, enclosure and other parts, and in the event of such damage, the product must not be charged until it has been repaired or replaced.

Use ONLY with the recommended charger.

## ☐ Wheels

Wheels and drive system are subject to normal wear and tear. It is the responsibility of the user to periodically inspect wheels for excess wear and adjust and replace drive train components as required.

## ☐ Replacement Parts

The most frequently requested replacement parts are available for purchase at some Razor retail partners. For the complete selection of replacement parts visit .

## ☐ Authorized Service Centers

For a list of authorized Razor service centers:

- Check online at [www.razor.com](http://www.razor.com).
- Additional Customer Service contact information is listed at the back of this manual.

**⚠ WARNING:** Regularly check the spoke tension and retighten the spokes whenever loose. If you have any doubt, ask an experienced motorcycle or bicycle mechanic to inspect your spokes to determine if the spokes need tightening or adjusting.

**⚠ WARNING:** To avoid a pinch or injury, keep fingers away from moving sprockets and chain.



**In the US and Canada only:**

For more information regarding recycling of rechargeable batteries, call toll free 1-800-822-8837, or visit <http://www.call2recycle.org>

**⚠ WARNING:** If a battery leak develops, avoid contact with the leaking acid and place the damaged battery in a plastic bag. Refer to the disposal instructions at left. If acid comes into contact with skin or eyes, flush with cool water for at least 15 minutes and contact a physician.

**⚠ WARNING:** Battery posts, terminals and related accessories contain lead and lead compounds. **Wash your hands after handling.**

# TROUBLESHOOTING GUIDE

**\*Product(s) should be turned OFF and fully charged prior to doing any troubleshooting.**

**NOTE: All troubleshooting steps should be performed by an adult only.**

<b>Problem</b>	<b>Possible Cause</b>	<b>Solution</b>
Does not work	Battery not fully charged	Charge unit for a full 12 hours.
	Loose connection(s)	Check for loose connections/wires. Check power to wall outlet and/or try a different outlet.
No longer works	Burned-out fuse	The fuse will burn out and automatically shut off the power if the motor is overloaded. An excessive overload, such as too heavy a rider or too steep a hill, could cause the motor to overheat. Replace the fuse(s) with a new one of equal amperage. Correct the conditions that caused the fuse to burn out and avoid repeatedly burning out fuse.
	Motor or electrical switch damage	Contact your local Razor authorized service center for diagnosis and repair.
	Loose connection(s)	Check for loose connections/wires. Check power to wall outlet and/or try a different outlet.
	Charger not working	Check lights on charger: Plugged into wall - Green Plugged into wall & unit - Red (charging) Plugged into wall & unit - Green (charging complete) No lights/Blinking lights - Replace Charger Secure unit, turn power <b>ON</b> with no weight on the unit, carefully lift up back end and apply the throttle to engage the motor. If motor engages - replace battery.
	Battery will not hold a charge	If motor does not engage, but makes a clicking sound - Replace Battery. If motor does not engage, no clicking sound - Replace Control Module.
Short run time/runs slow	Rider weight	Do not exceed the weight limit of 175 lb (79 kg) for SX500/MX500 and 220 lb (100 kg) for MX650.
	Battery not fully charged	Charge unit for a full 12 hours.
	Old/damaged battery	Check all connectors. Make sure the charger connector is tightly plugged into the charging port, and that the charger is plugged into the wall. Secure unit, turn power <b>ON</b> with no weight on the unit, carefully lift up back end and apply the throttle to engage the motor. If motor engages - replace battery. Charge battery periodically when not in use.
	Improper battery maintenance	Do not store unit in freezing or below freezing temperatures. Freezing will permanently damage the battery and greatly reduce ride time. Refer to page 6 "Charging the Battery".
	Tires are not properly inflated	Tires will lose some pressure over time. Verify correct tire pressure.
	Brakes are not adjusted properly	Refer to "Adjusting the Brakes" on page 7.

# TROUBLESHOOTING GUIDE

<b>Problem</b>	<b>Possible Cause</b>	<b>Solution</b>
Runs intermittently	Loose connection(s) Motor or electrical switch damage	Check for loose connections/wires. Contact your local Razor authorized service center for diagnosis and repair.
Electric motor bike does not stop when applying the brake	Brakes are not adjusted properly	Refer to "Adjusting the Brakes" on page 7
Electric motor bike makes loud noises or grinding sounds	Chain is too dry	Apply a lubricant, such as 3 in 1™ or Tri-Flow™ to the chain.

For more troubleshooting tips, a list of available replacement parts or to locate an authorized Service Center in your area, visit our website at [www.razor.com](http://www.razor.com) or call toll free +1 866-467-2967 to speak to a live Customer Service Representative.

**Need Help?** Visit our website for replacement parts, product support, a list of authorized service centers in the US and customer service contact information at [www.razor.com](http://www.razor.com). Please have the product I.D. code (located on the white label of your product) available for better assistance. Additional Customer Service contact information is listed at the back of this manual.

# PRODUCT PARTS

Keep your electric motor bike running for years with genuine Razor parts. Visit our website for more information on spare part availability. (Illustrations may not reflect exact appearance of actual product. Specifications subject to change without notice.)

- |                                       |  |                               |
|---------------------------------------|--|-------------------------------|
| 1. Handlebar Grip (Right/Left)        | 8. Handlebar Clamp (Upper/Lower)                           | 15. Kickstand                 |
| 2. Twist-Grip Throttle<br>2-1 Sleeve  | 9. Front Wheel Complete                                    | 16. Rear Wheel Complete       |
| 3. Front Brake Lever Assembly (Right) | 10. Caliper Brake (x2)                                     | 17. Chain                     |
| 4. Handlebar                          | 11. Shock Absorber   | 18. Chain Guard               |
| 5. Rear Brake Lever Assembly (Left)   | 12. Control Module   | 19. Batter Cover (Left/Right) |
| 6. Front Fork                         | 13. Battery (3- 12V/12Ah) w/ Fuses                         | 20. On/Off Switch             |
| 7. Front Fender                       | 14. SX500/MX500 Motor (36V/500W)<br>MX650 Motor (36V/650W) | 21. Charger Port              |
|                                       |  | 22. Seat Fairing              |

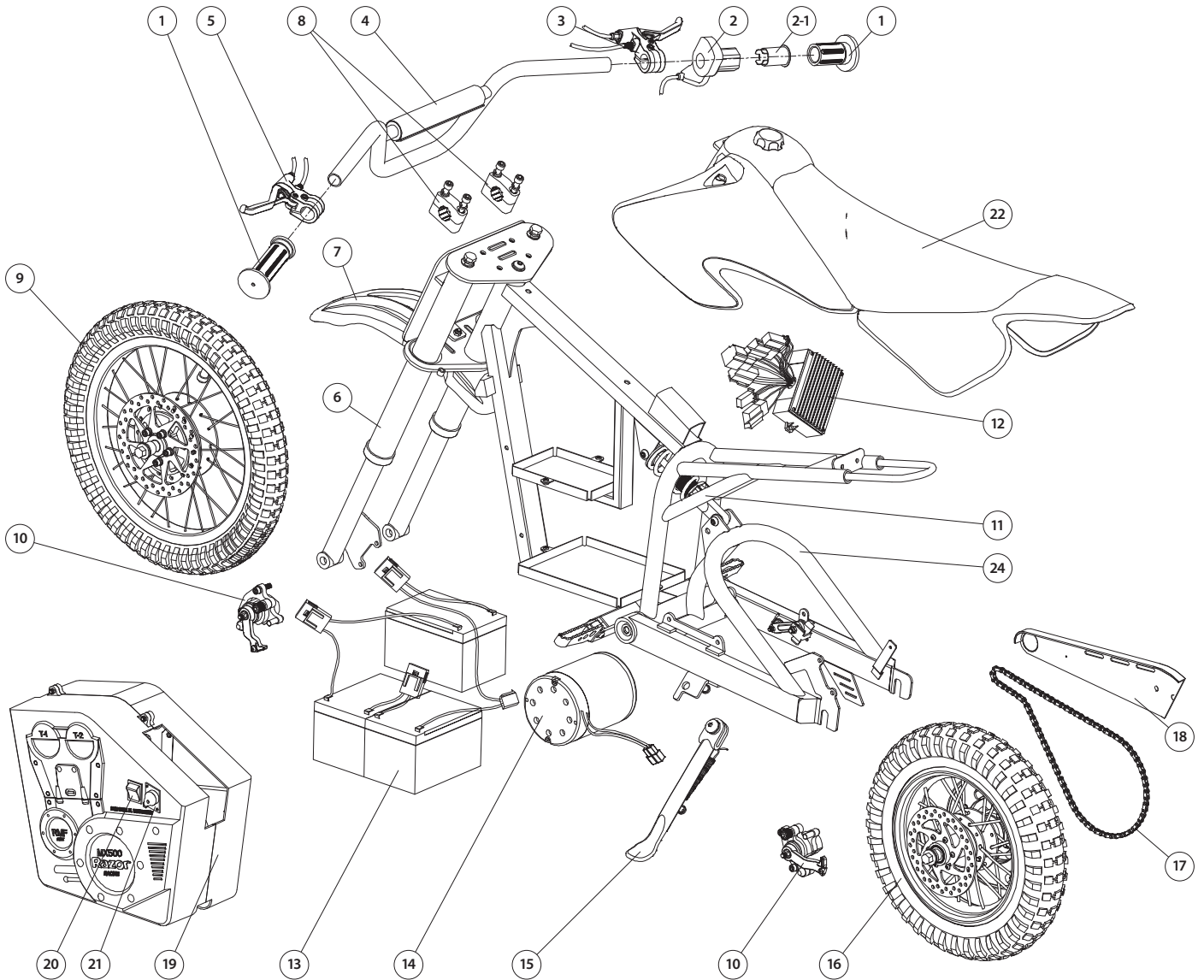



**NOTICE: INSURANCE**

**YOUR INSURANCE POLICIES MAY NOT PROVIDE COVERAGE FOR ACCIDENTS INVOLVING THE USE OF THIS SCOOTER/ELECTRIC RIDE-ON PRODUCT. TO DETERMINE IF COVERAGE IS PROVIDED, YOU SHOULD CONTACT YOUR INSURANCE COMPANY OR AGENT.**

## FCC COMPLIANCE

This device complies with Part 15 of the FCC Rules. Operation is subject to the following two conditions: (1) This device may not cause harmful interference, and (2) this device must accept any interference received, including interference that may cause undesired operation.

Note: This equipment has been tested and found to comply with the limits for a Class B digital device, pursuant to part 15 of the FCC Rules. These limits are designed to provide reasonable protection against harmful interference in a residential installation. This equipment generates, uses and can radiate radio frequency energy and, if not installed and used in accordance with the instructions, may cause harmful interference to radio communications. However, there is no guarantee that interference will not occur in a particular installation. If this equipment does cause harmful interference to radio or television reception, which can be determined by turning the equipment off and on, the user is encouraged to try to correct the interference by one or more of the following measures:

- Reorient or relocate the receiving antenna.
- Increase the separation between the equipment and receiver.
- Connect the equipment into an outlet on a circuit different from that to which the receiver is connected.
- Consult the dealer or an experienced radio/TV technician for help.

**⚠ WARNING:** Changes or modifications to this unit not expressly approved by Razor USA, could void the user's authority to operate the equipment.

## WARRANTY

### Razor Limited Warranty

The manufacturer warrants this product to be free of manufacturing defects for a period of 90 days from date of purchase. This Limited Warranty does not cover normal wear and tear, tires, tubes or cables, or any damage, failure or loss caused by improper assembly, maintenance, storage or use of the Razor Dirt Rocket SX500, MX500 and MX650.

This Limited Warranty will be void if the product is ever:

- used in a manner other than for recreation or transportation;
- modified in any way;
- rented.

The manufacturer is not liable for incidental or consequential loss or damage due directly or indirectly to the use of this product.

Razor does not offer an extended warranty. If you have purchased an extended warranty, it must be honored by the store at which it was purchased.

For your records, save your original sales receipt with this manual and write the serial number below.

-----

## CUSTOMER SERVICE CONTACT INFORMATION

**Need Help?** Visit our website for product support, a list of authorized service centers in the US and customer service contact information at [www.razor.com](http://www.razor.com). Please have the product I.D. code (located on the white label of your product) available for better assistance. Additional Customer Service contact information is listed below:

### AMERICAS

Razor USA LLC  
P.O. Box 3610  
Cerritos, CA 90703  
USA

+1 866 467 2967  
Monday - Friday  
8:00 AM - 5:00 PM Pacific Time  
customersupport@razorusa.com

### EUROPE, MIDDLE EAST, AFRICA

Razor USA LLC (Europe)  
Handelsweg 2  
2742 RD Waddinxveen  
Netherlands

+44 (0) 120 267 2702  
info@razoreu.com

### ASIA

Razor USA LLC (Asia)  
P.O. Box 3610  
Cerritos, CA 90703  
USA

+81 50 7579 6622  
info@razor-asia.com

### UNITED KINGDOM AND IRELAND

Razor USA LLC (UK)  
Unit 20  
Hartnoll Business Centre  
Post Hill, Tiverton  
Devon EX16 4NG  
UK

+44 (0) 120 267 2702  
info@razoreu.com

### AUSTRALIA AND NEW ZEALAND

Razor USA LLC  
P.O. Box 4280  
Auburn South  
VIC 3122  
Australia

+1 800 954 354 (AU)  
+0 800 003 221 (NZ)  
info@razoranz.com

### IMPORTED IN JAPAN BY B-PLUS ASIA CORP.

Razor USA LLC  
**THE RIZSTIK COMPANY**  
Kurokawa 3-1, Asaoku,  
Kawasaki, Kanagawa  
215-0035 JAPAN

+81 (0) 44 328 9057 Tel  
+81 (0) 44 328 9067 Fax  
info@razor-asia.com

Printed in China for Razor USA LLC.

Copyright © 2003-2021 Razor USA, LLC. All rights reserved. Razor® and the Razor logo design are among the registered trademarks of Razor USA LLC in the United States and/or select foreign countries. Dirt Rocket™ and the Dirt Rocket logo design are trademarks of Razor USA LLC.

US\_210331