

 **Razor Jr**
Lip Kick™
SCOOTER



OWNER'S MANUAL

**Read and understand this entire manual before allowing child to use this product! For assistance contact Razor.
DO NOT RETURN TO STORE.**

**NOTE: Manual illustrations are for demonstration purposes only.
Illustrations may not reflect exact appearance of actual product.
Specifications subject to change without notice.**

**Please have your product along with the 22 character product I.D. code with you
before contacting Razor for warranty assistance and/or replacement parts.**

Product I.D. Code: _____ - _____ - _____

CONTENTS

Safety Warnings	1	Usage	5
Before You Begin	2	Repair and Maintenance	5
Assembly and Set-up	3-4	Product Parts	6
Pre-Ride Checklist	5	Warranty and Contact Information	7

SAFETY WARNINGS

! AN IMPORTANT MESSAGE TO PARENTS:

Razor® Jr. products are intended to allow younger children to learn and to enjoy their early experiences using ride-on toys. Studies suggest that children at age 3 have the coordination required to use a steering wheel or handlebar and can use a 3-wheeled scooter, but may not have developed the balance required to operate 2-wheeled scooters. This ability is expected to develop with time and experience to where, depending on experience, most children by the age of 5 have the balance and coordination to use 2-wheeled scooters. Adult supervision is required as children learn and grow because children do not understand the risks of riding in areas with cars and are at a very high risk of falling and injuring themselves.

This manual contains important information. For your child's safety, it is your responsibility to review this information and make sure that you instruct your child to follow all warnings, cautions, instructions and safety topics. Razor USA recommends that you periodically review and reinforce the information in this manual with younger riders and that you inspect and maintain your child's Razor Jr. scooter to insure their safety.

! GENERAL WARNING: Scooter riding can be a hazardous activity. Scooters can and are intended to move, and it is therefore possible to get into dangerous situations and/or lose control and/or fall. If such things occur you can be seriously injured or die. LIKE ANY OTHER MOVING PRODUCT, USING A SCOOTER CAN BE A DANGEROUS ACTIVITY AND MAY RESULT IN INJURY OR DEATH EVEN WHEN USED WITH PROPER SAFETY PRECAUTIONS. USE AT YOUR OWN RISK AND USE COMMON SENSE.

This manual contains many warnings and cautions concerning the consequences of failing to maintain, inspect or properly use your scooter. Because any incident can result in serious injury or even death, we do not repeat the warning of potential serious injury or death each time such a possibility is mentioned.

- Do not allow children under age three (3) to use the scooter. Close adult supervision is required.
- Do not exceed 44 lb (20 kg) total weight on the Razor Jr. scooter.
- Rider weight does not necessarily mean a child's size is appropriate to fit or maintain control of the scooter.
- This product has no brake. Place feet on floor to stop.
- Always pay attention to where your child is going.
- Always wear safety equipment, such as helmet, knee pads and elbow pads. Always wear a helmet when riding your scooter and keep the chinstrap securely buckled.
- Always wear closed toe shoes.
- Ride on smooth, paved surfaces without loose debris, such as rocks or gravel, and away from motor vehicles.
- Avoid sharp bumps, drainage grates, and sudden surface changes as scooter may suddenly stop.

- Avoid streets and surfaces with water, mud, ice, sand, gravel, dirt, leaves and other debris. Wet weather impairs traction, stopping, and visibility.
- Do not ride at night or when visibility is impaired.
- Avoid excessive speed associated with downhill rides.
- Obey all local traffic and scooting laws and regulations.
- Watch out for pedestrians.
- A parent's decision to allow his or her child to ride this product should be based on the child's maturity, skill and ability to follow rules.

ACCEPTABLE RIDING PRACTICES AND CONDITIONS

Direct parental supervision is required at all times. Scooters are meant to be used only in controlled environments, free of potential traffic hazards and not on public streets. Do not allow your child to ride a scooter in any areas where vehicle traffic is present. Child must maintain a hold on the handlebar at all times. Never allow more than one child at a time to ride a scooter. Never use near steps, sloped driveways, hills, roadways, alleys or swimming pool areas.

PROPER RIDING ATTIRE

Always ensure child is wearing proper protective equipment, such as an approved safety helmet. A helmet may be legally required by local law or regulation in your area. A child should always wear shoes and keep shoelaces tied and out of the way of the wheels. Never ride barefooted or in sandals. Knee pads and elbow pads are recommended.

! WARNING: ALWAYS INSPECT SCOOTER PRIOR TO RIDING. Properly inspecting and maintaining your scooter can reduce the risk of injury. Always inspect your scooter before riding and regularly maintain it. Replace worn or broken parts immediately.

! WARNING: CHECK LOCAL LAWS REGARDING SCOOTER USE. Check local laws and regulations to see where and how you may use your scooter legally. In many states and local areas scooter riders are required BY LAW to wear a helmet. Check local laws and regulations regarding laws governing helmet use and scooter operation in your area.

FAILURE TO USE COMMON SENSE AND HEED THE ABOVE WARNINGS FURTHER INCREASES RISK OF SERIOUS INJURY. USE AT YOUR OWN RISK AND WITH APPROPRIATE AND SERIOUS ATTENTION TO SAFE OPERATION. USE CAUTION.

BEFORE YOU BEGIN

Adult assembly required. Remove contents from box. Inspect the contents for scratches in the paint and/or dents that may have occurred during shipping. Because your scooter was partially assembled and packed at the factory, there should not be any problems, even if the box has a few scars or dents.

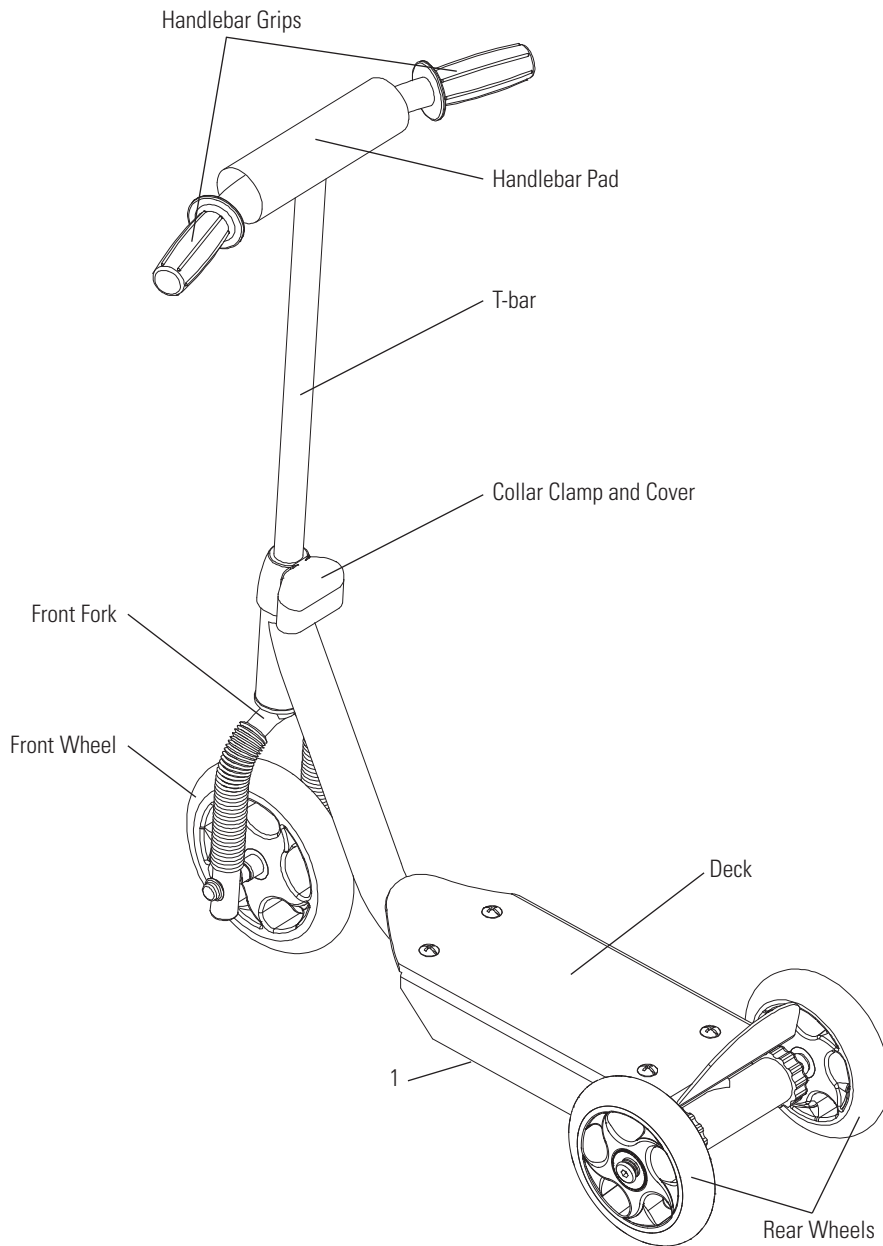

Required Tool(s)

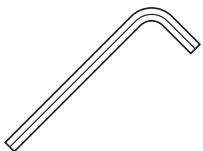

Two (2) 5 mm Allen Wrench

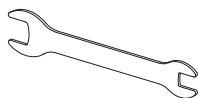

10 mm/13mm Wrench

WARNING: DO NOT USE NON-RAZOR PRODUCTS WITH YOUR RAZOR JR. SCOOTER.

Razor Jr. scooters have been built to certain Razor design specifications. The original equipment supplied at the time of sale was selected on the basis of its compatibility with the frame and all other parts. Certain aftermarket products may not be compatible and will void the warranty.

Product I.D. Locations:

(See locations to the left)

1. Deck (Underneath Unit)
2. Box - Side of UPC (Not Shown)

Box Contents:

- Scooter
- Tools
- Owner's Manual

Need Help? Visit our website for replacement parts, product support, a list of authorized service centers in the US and customer service contact information at www.razor.com. Please have the product I.D. code (located on the white label of your product) available for better assistance. Additional Customer Service contact information is listed at the back of this manual.

ASSEMBLY AND SET-UP

□ Handlebar Assembly

Tool Required: 10 mm Wrench

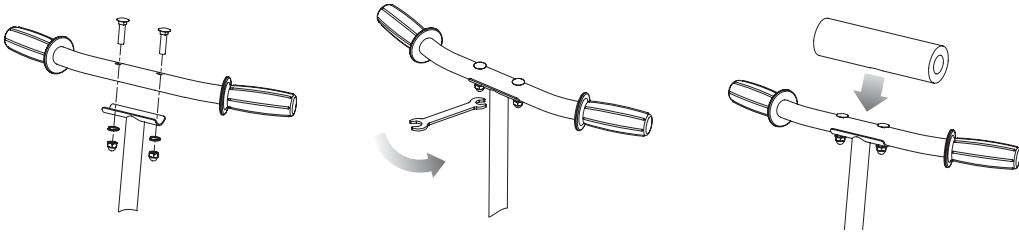

1 Align the holes on the handlebar and the T-bar. Insert handlebar bolts into the top of the handlebar and through the T-bar. Install the washers and nuts onto the bottom of the handlebar bolts. Tighten securely into place using a 10 mm wrench.

2 Place the handlebar pad over the handlebar and secure tightly with the velcro cover.

□ Rear Wheel Assembly

Tools Required: Two (2) 5 mm Allen Wrenches

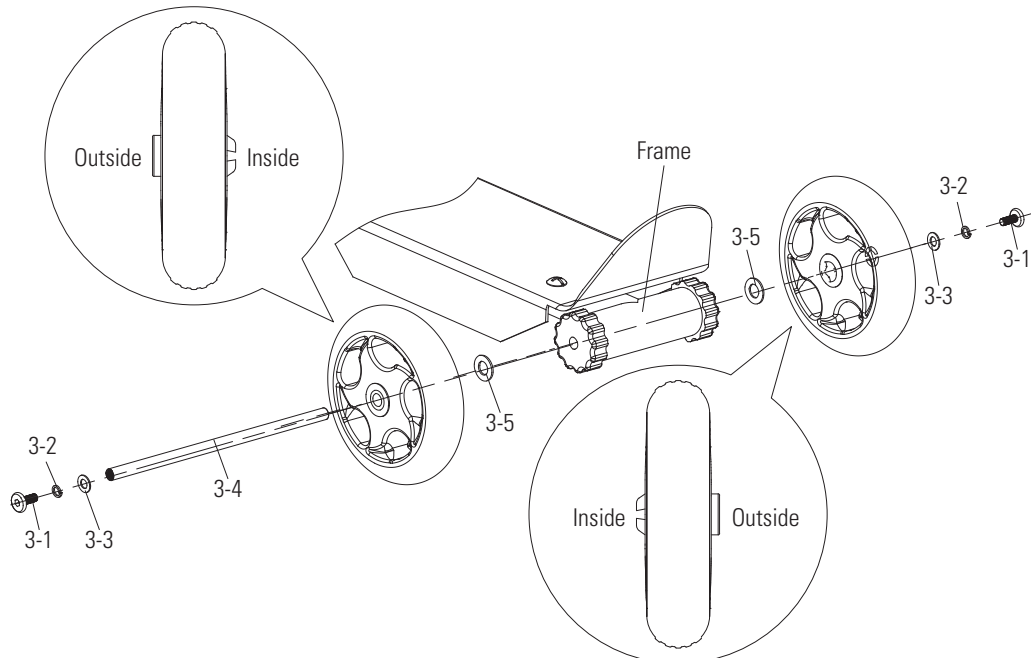

1 Remove the locking screw (3-1), spring washer (3-2), small washer (3-3) and large washer (3-5) **from one side** of the axle bolt. Insert the axle bolt through the rear wheel. Insert the large washer (3-5) onto the axle bolt between the frame and rear wheel and slide the axle bolt through the frame. Slide the other large washer and wheel onto the axle bolt.

Note: Wheels are interchangeable.

Rear wheel hardware sequence

- 3-1 Locking Screw
- 3-2 Spring Washer
- 3-3 Washer (Small)
- 3-4 Axle Bolt

Wheel

- 3-5 Washer (Large)

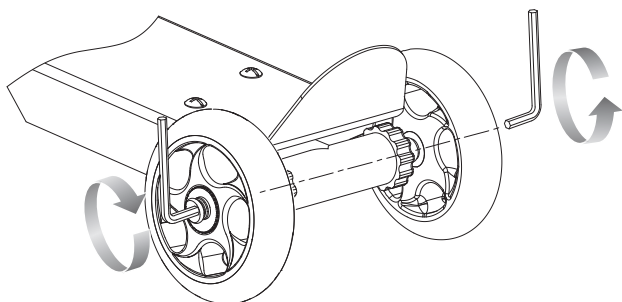

2 Tighten securely using two (2) 5 mm Allen wrenches.

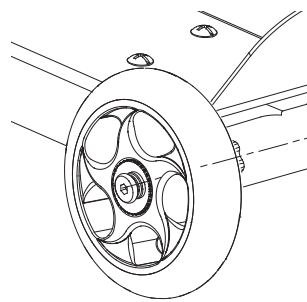

3 Make sure the locking screw, spring washer and small washer are securely tightened against the wheel.

ASSEMBLY AND SET-UP

□ Front Fork Assembly

Tool Required: 13 mm Wrench

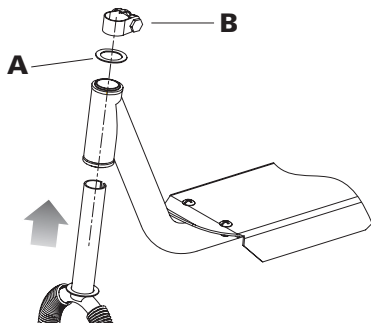

1 Remove the black protective cover from the top of the fork. Using a 13 mm wrench, loosen collar clamp bolt and slide collar clamp (B) up the fork and remove. Remove washer (A) from fork. Insert the front fork into the steering tube. Slide washer (A) back onto the front fork. Slide collar clamp (B) back down onto the fork until it is sitting directly on top of washer (A).

□ T-bar Assembly

Tool Required: 13 mm Wrench

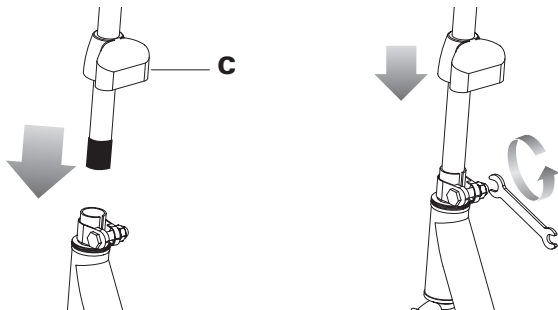

1 Slide collar clamp cover (C) up to the middle of the T-bar. Insert the T-bar all the way down into the front fork.

2 Align the handlebar with the front wheel and using a 13 mm wrench, tighten the collar clamp bolt until the handlebar is locked securely into place. Slide the collar clamp cover down over the collar clamp.

A	
B	
C	

Need Help? Visit our website for replacement parts, product support, a list of authorized service centers in the US and customer service contact information at www.razor.com. Please have the product I.D. code (located on the white label of your product) available for better assistance. Additional Customer Service contact information is listed at the back of this manual.

PRE-RIDE CHECKLIST



Frame, Fork and Handlebar

Check for cracks or broken connections. Although broken frames are rare, it is possible for an aggressive rider to run into a curb or object and wreck, bend or break a frame. Get in the habit of inspecting your scooter on a regular basis.



Hardware/Loose Parts

Before every ride, check all parts, such as nuts, bolts, cables, fasteners, etc., to ensure they are secure and assembled correctly. There should not be any unusual rattles or sounds from loose parts or broken components. If the unit is damaged, do not ride. **Reference "Safety Warnings" on page 1 of this manual.**



Safety Gear

Always wear proper protective gear, such as an approved safety helmet. Elbow pads and kneepads are recommended. Always wear athletic shoes (lace-up shoes with rubber soles) and keep shoelaces tied and out of the way of the wheels. **NEVER RIDE BAREFOOTED OR IN SANDALS.**



Laws and Regulations

Always check and obey any local laws or regulations.

USAGE

How to Ride

Place one foot on the baseboard and push forward with the other foot. Ride with both hands on the handlebar. To turn, move handlebar in the direction you wish to travel. Step off to stop.

REPAIR AND MAINTENANCE

Cleaning

Wipe with a damp cloth to remove dirt and dust. Do not use industrial cleaners or solvents, as they may damage the surfaces. Do not use alcohol, alcohol-based or ammonia-based cleaners, as they may damage or dissolve the plastic components or soften the decals or decal adhesive.

Wheels

Under normal circumstances and conditions, Razor wheels are maintenance free. Nonetheless, it is the responsibility of the owner or guardian to periodically inspect the wheels for wear and tear, the axle for proper tightness, and for loose parts. When a wheel develops play, this is an indication of excess wear and replacement is necessary. Replace immediately with only genuine Razor wheels. Worn wheels are considered normal wear-and-tear and are not covered by the Razor Warranty. Wheels other than genuine Razor wheels may not be compatible with your Razor Jr. scooter. The use of anything other than genuine Razor replacement parts may affect your safety and will void your warranty.

Replacement Parts

The most frequently requested replacement parts are available for purchase at some Razor retail partners. For the complete selection of replacement parts visit shop.razor.com.

Repair Centers

For a list of authorized Razor repair centers:

- Check online at www.razor.com.
- Additional Customer Service contact information is listed at the back of this manual.

PRODUCT PARTS

Keep your product working for years with genuine Razor parts. Visit our website for more information on spare part availability. (Specifications subject to change without notice.)

- | | | | |
|------------------------|----------------------------------|---------------------------------------|----------------------------------|
| 1. Handlebar Grip (x2) | 5. Collar Clamp Cover | 9. Front Wheel | 11. Rear Wheel (x2) |
| 2. Handlebar Pad | 6. Collar Clamp | 9-1 Fixed Cap (x2) | 11-1 Short Bushing / Spacer (x4) |
| 3. Handlebar | 6-1 Bolt | 9-2 C Clip (x2) | 12. Rear Axle Bolt |
| 3-1 Bolt (x2) | 6-2 Spring | 9-3 Front Axle | 12-1 Rear Tube Cover (x2) |
| 3-2 Spring Washer (x2) | 6-3 Lock Nut | 9-4 Front Wheel Bushing / Spacer (x2) | 12-2 Washer (Large) (x2) |
| 3-3 Nut (x2) | 7. Washer | 10. Front Fork | 12-3 Washer (Small) (x2) |
| 4. T-bar | 8. Plastic Headset (Upper/Lower) | 10-1 Fork Cover (x2) | 12-4 Spring Washer (x2) |
| | | | 12-5 Locking Screw (x2) |

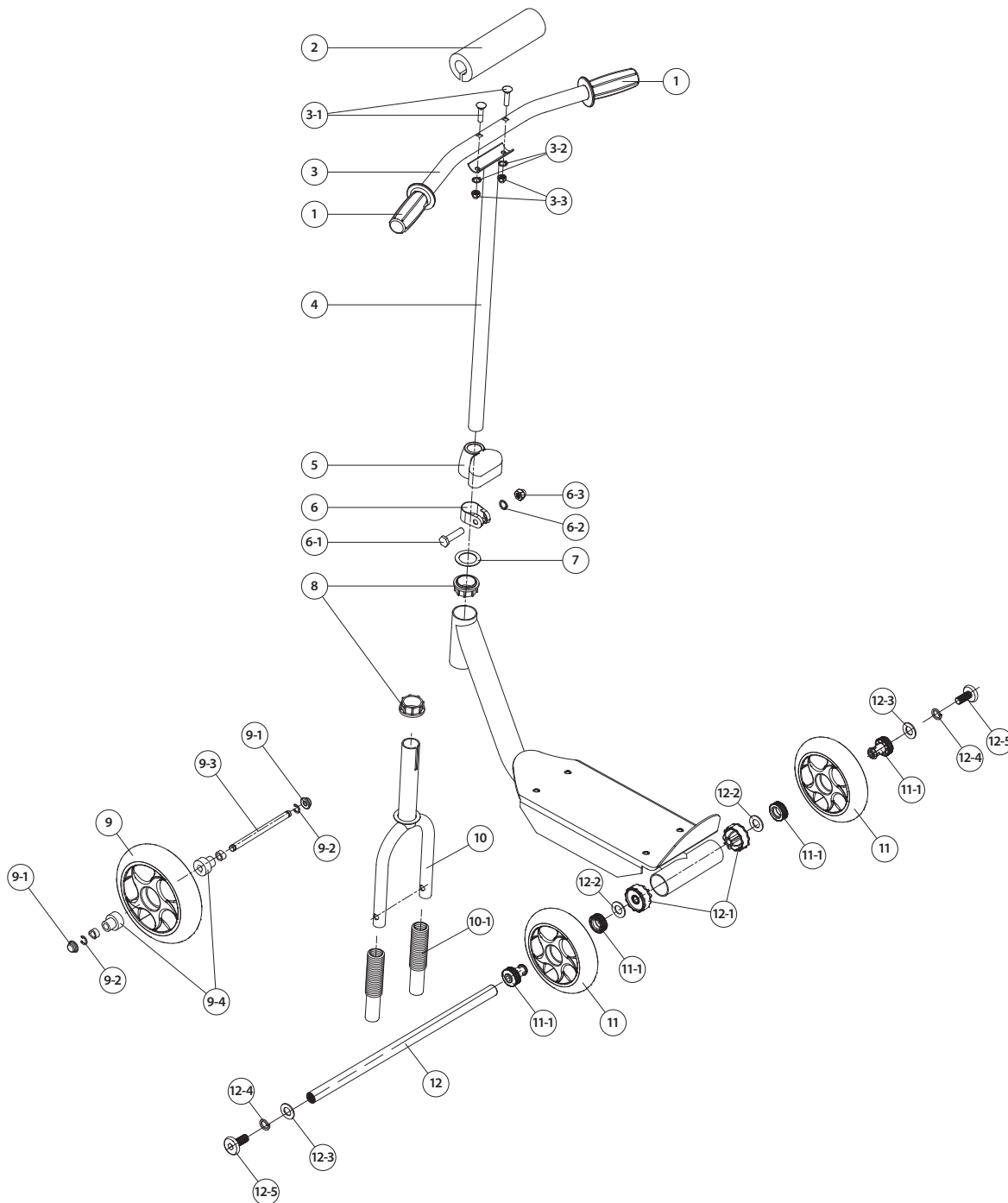

Need Help? Visit our website for replacement parts, product support, a list of authorized service centers in the US and customer service contact information at www.razor.com. Please have the product I.D. code (located on the white label of your product) available for better assistance. Additional Customer Service contact information is listed at the back of this manual.

WARRANTY

Razor Limited Warranty

The manufacturer warrants this product to be free of manufacturing defects for a period of 6 months from date of purchase. This Limited Warranty does not cover normal wear and tear, or any damage, failure or loss caused by improper assembly, maintenance, storage, or use of the Lil' Kick scooter.

This Limited Warranty will be void if the product is ever:

- used in a manner other than for recreation;
- modified in any way;
- rented.

The manufacturer is not liable for incidental or consequential loss or damage due directly or indirectly to the use of this product.

Razor does not offer an extended warranty. If you have purchased an extended warranty, it must be honored by the store at which it was purchased.

For your records, save your original sales receipt with this manual and write the serial number below.

CUSTOMER SERVICE CONTACT INFORMATION

Need Help? Visit our website for replacement parts, product support, a list of authorized service centers in the US and customer service contact information at www.razor.com. Please have the product I.D. code (located on the white label of your product) available for better assistance. Additional Customer Service contact information is listed below:

AMERICAS

Razor USA LLC
P.O. Box 3610
Cerritos, CA 90703
USA

+1 866 467 2967
Monday - Friday
8:00 AM - 5:00 PM Pacific Time
customersupport@razorusa.com

EUROPE, MIDDLE EAST, AFRICA

Razor USA LLC (Europe)
Handelsweg 2
2742 RD Waddinxveen
Netherlands

+44 (0) 120 267 2702
info@razoreu.com

ASIA

Razor USA LLC (Asia)
P.O. Box 3610
Cerritos, CA 90703
USA

+81 50 7579 6622
info@razor-asia.com

UNITED KINGDOM AND IRELAND

Razor USA LLC (UK)
Unit 20
Hartnoll Business Centre
Post Hill, Tiverton
Devon EX16 4NG
UK

+44 (0) 120 267 2702
info@razoreu.com

DISTRIBUTED IN AUSTRALIA BY:

Funtastic Limited
Suite 2.01, Level 2
315 Ferntree Gully Road
Mount Waverley VIC 3149,
Australia

+1 800 244 543
info@funtastic.com.au

Printed in China for Razor USA LLC.

Copyright © 2003-2020 Razor USA, LLC. All rights reserved. Razor® and the Razor logo design are among the registered trademarks of Razor USA LLC in the United States and/or select foreign countries. Razor Jr. and Lil' Kick logo designs are trademarks of Razor USA LLC.