



MASSIMO

POWERFUL. AFFORDABLE. RELIABLE.



WWW.MASSIMOMOTOR.COM





MASSIMO

POWERFUL. AFFORDABLE. RELIABLE.

TABLE OF CONTENTS

About Us	1
UTVs	2 - 21
ATVs	22 - 25
Go-Karts	26 - 27
Motorcycles	28 - 29
Snow Equipment	30



THE MASSIMO STORY

IMAGINE COMING TO A DISTANT FOREIGN LAND WITH ABOUT A HUNDRED BUCKS IN YOUR POCKET, A SUITCASE WITH JUST A FEW PERSONAL ITEMS AND COUPLE WIDGETS YOU THINK MIGHT SELL. KNOWING NO ONE, NO JOB, NO PLACE TO LIVE AND CAN'T SPEAK THE LANGUAGE. IN FACT, THE ONLY THING YOU HAVE IS A DREAM.

It's from these incredibly humble beginnings where the Massimo story truly begins. Learning real fast through hard work, practice and perseverance that people will and in fact want to buy, if your product quality is good, price is good, and service is good. This simple, yet hard earned statement..."Good Price, Good Quality and Good Service" is in fact our foundation at Massimo Motor.

FOUNDED IN 2009

Our pride and joy is our 325,000 square foot factory in the heart of the Dallas / Fort Worth area of Texas USA, in the city of Garland. It's here we offer some of the most sought after, value packed UTV's, off-road, and on-road vehicles in the industry. Our vast product lines include a wide selection of farm and ranch tested utility UTV's, recreational ATV's, and Americana style mini-bikes. We work hard to continue to deliver one of the most diverse, value packed and expansive product-lines in the industry.

OUR ROOTS GROW DEEP

Massimo is proud partners with 1000's of service centers, full-line dealers and handpicked retailers to ensure each and every Massimo customer receives the best customer service and support experience possible. The shared passion of our customers has always been our greatest motivation in bringing products with good quality, good price and good service to the market.



BUCK 200



DIMENSIONS

- VEHICLE SIZE (L X W X H): 105 IN X 54 IN X 73 IN
- WHEELBASE: 63 IN
- GROUND CLEARANCE: 11 IN
- CARGO BED (L X W X H): 34.75 IN X 48 IN X 11.5 IN
- CARGO BED CAPACITY: 220 LBS
- FUEL CAPACITY: 4.8 GALLONS
- SEAT HEIGHT: 33 IN
- DRY WEIGHT: 828 LBS



4 STROKE SINGLE CYLINDER

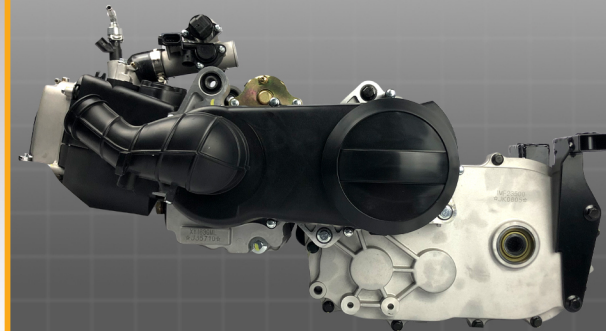

- ENGINE TYPE: FOUR STROKE SINGLE CYLINDER
- DISPLACEMENT: 177CC
- HORSEPOWER: 8.7 HP
- COOLING: AIR COOLED
- TRANSMISSION/FINAL DRIVE: AUTOMATIC P/R/N/F, SHAFT DRIVE
- DRIVE SYSTEM: 2WD
- FUEL SYSTEM: FUEL INJECTED

CHASSIS

- FRONT SUSPENSION: MACPHERSON INDEPENDENT
- REAR SUSPENSION: INDEPENDENT DUAL A-ARM
- FRONT TIRES: AT 24X 8-12
- REAR TIRES: AT 24X 8-12
- FRONT BRAKES: HYDRAULIC DISK BRAKES
- REAR BRAKES: HYDRAULIC DISK BRAKES

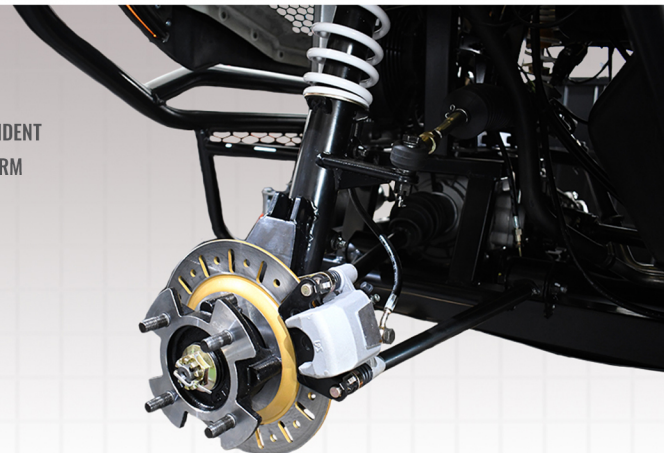

ADDITIONAL FEATURES

- WARRANTY: 1 YEAR PARTS & LABOR
- BATTERY: 12V 35AMP
- ASSEMBLED IN TEXAS, USA
- INSTRUMENTATION: DIGITAL DISPLAY, SPEEDOMETER, ODOMETER, TACHOMETER, HOUR METER, GEAR INDICATOR, TRIP METER, HEADLIGHTS (HIGH/LOW), TURN SIGNALS, FUEL GAUGE, HI-TEMP





BUCK 200 X



DIMENSIONS

- VEHICLE SIZE (L X W X H): 105 IN X 54 IN X 73 IN
- WHEELBASE: 63 IN
- GROUND CLEARANCE: 11 IN
- FUEL CAPACITY: 4.8 GALLONS
- SEAT HEIGHT: 33 IN
- DRY WEIGHT: 828 LBS



73" HEIGHT

4 STROKE SINGLE CYLINDER

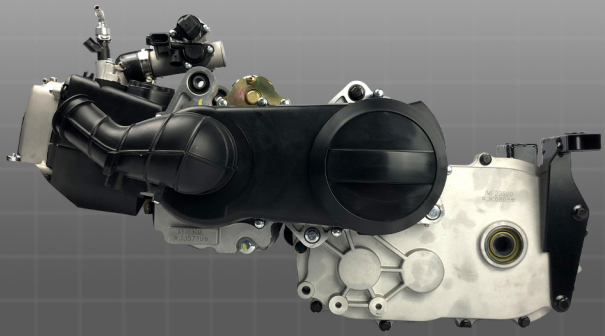

- ENGINE TYPE: FOUR STROKE SINGLE CYLINDER
- DISPLACEMENT: 177CC
- HORSEPOWER: 8.7 HP
- COOLING: AIR COOLED
- TRANSMISSION/FINAL DRIVE: AUTOMATIC P/R/N/F, SHAFT DRIVE
- DRIVE SYSTEM: 2WD
- FUEL SYSTEM: FUEL INJECTED

CHASSIS

- FRONT SUSPENSION: MACPHERSON INDEPENDENT
- REAR SUSPENSION: INDEPENDENT DUAL A-ARM
- FRONT TIRES: AT 24X 8-12
- REAR TIRES: AT 24X 8-12
- FRONT BRAKES: HYDRAULIC DISK BRAKES
- REAR BRAKES: HYDRAULIC DISK BRAKES

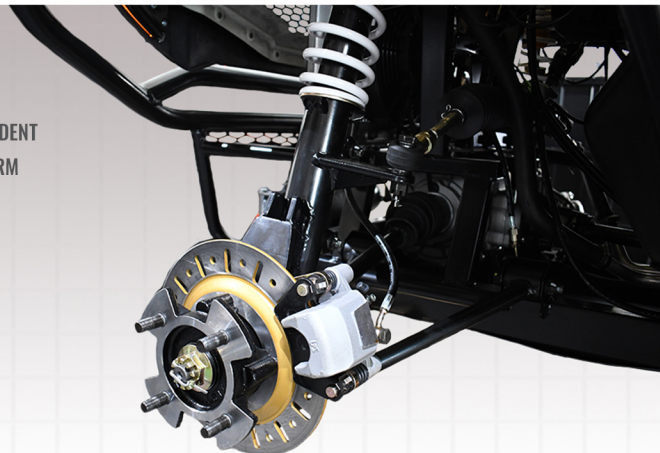

ADDITIONAL FEATURES

- WARRANTY: 1 YEAR PARTS & LABOR
- BATTERY: 12V 35AMP
- ASSEMBLED IN TEXAS, USA
- INSTRUMENTATION: DIGITAL DISPLAY, SPEEDOMETER, ODOMETER, TACHOMETER, HOUR METER, GEAR INDICATOR, TRIP METER, HEADLIGHTS (HIGH/LOW), TURN SIGNALS, FUEL GAUGE, HI-TEMP





BUCK 60



DIMENSIONS

- VEHICLE SIZE (L X W X H): 105 IN X 54 IN X 73.5 IN
- WHEELBASE: 63 IN
- GROUND CLEARANCE: 11.5 IN
- SEAT HEIGHT: 33 IN
- DRY WEIGHT: 1,236 LBS



XQ-3.8 ELECTRIC TRACTION MOTOR

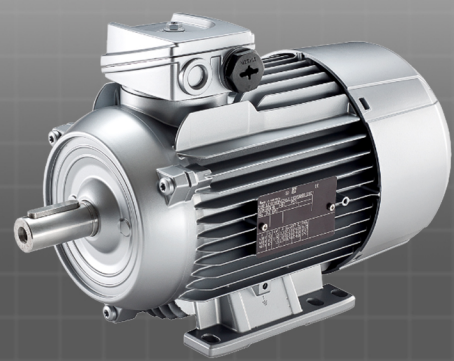

- ENGINE TYPE: BRUSHLESS
- MAXIMUM CONTINUOUS RATED POWER: 4KW
- OPERATING VOLTAGE: 60V
- CAPACITY: 185AH@5HR RATE
- QUANTITY OF BATTERIES: 5
- ACTIVE AXLE: REAR AXLE
- LIMITED DRIVING DISTANCE: 80KM

CHASSIS

- FRONT SUSPENSION: MACPHERSON INDEPENDENT
- REAR SUSPENSION: INDEPENDENT DUAL A-ARM
- FRONT TIRES: AT 24X 8-12
- REAR TIRES: AT 24X 8-12
- FRONT BRAKES: HYDRAULIC DISK BRAKES
- REAR BRAKES: HYDRAULIC DISK BRAKES

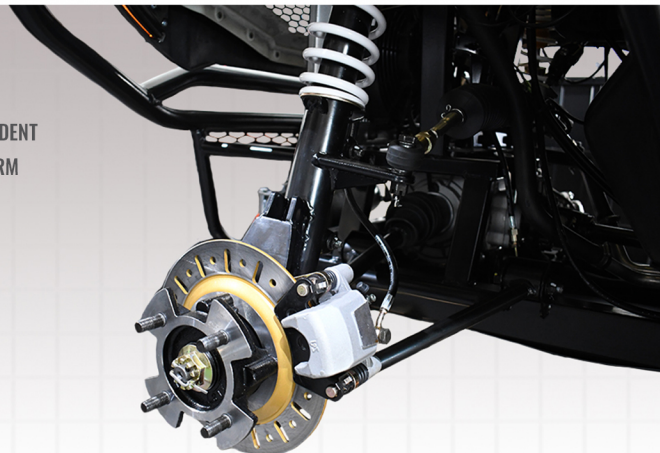

ADDITIONAL FEATURES

- WARRANTY: 1 YEAR PARTS & LABOR
- BATTERY: 12V
- ASSEMBLED IN TEXAS, USA
- INSTRUMENTATION: DIGITAL DISPLAY, SPEEDOMETER, ODOMETER, TACHOMETER, HOUR METER, GEAR INDICATOR, TRIP METER, HEADLIGHTS (HIGH/LOW), TURN SIGNALS,





BUCK 400



DIMENSIONS

- VEHICLE SIZE (L X W X H): 103 IN X 56.5 IN X 74.5 IN
- WHEELBASE: 74 IN
- GROUND CLEARANCE: 9 IN
- CARGO BED (L X W X H): 34.75 IN X 48 IN X 11.5 IN
- TOWING CAPACITY: 1,000 LBS
- CARGO BED CAPACITY: 400 LBS
- FUEL CAPACITY: 4.8 GALLONS
- SEAT HEIGHT: 34.5 IN
- DRY WEIGHT: 992 LBS



4 STROKE SINGLE CYLINDER

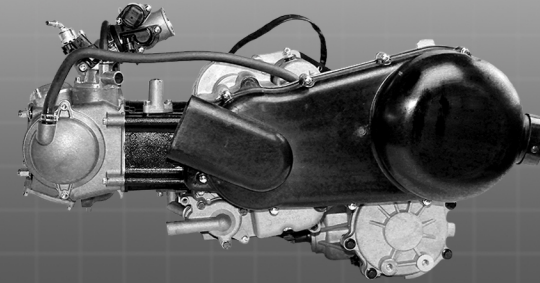

- ENGINE TYPE: FOUR STROKE SINGLE CYLINDER
- DISPLACEMENT: 391CC
- HORSEPOWER: 25 HP
- COOLING: LIQUID COOLED
- TRANSMISSION/FINAL DRIVE: AUTOMATIC CVT P/R/N/L/H, SHAFT DRIVE
- DRIVE SYSTEM: 2WD/4WD, LOCKING DIFFERENTIAL
- FUEL SYSTEM: ELECTRONIC FUEL INJECTION(EFI)

CHASSIS

- FRONT SUSPENSION: MACPHERSON INDEPENDENT
- REAR SUSPENSION: INDEPENDENT DUAL A-ARM
- FRONT TIRES: AT 25X 8-12
- REAR TIRES: AT 25X 10-12
- FRONT BRAKES: HYDRAULIC DISK BRAKES
- REAR BRAKES: HYDRAULIC DISK BRAKES

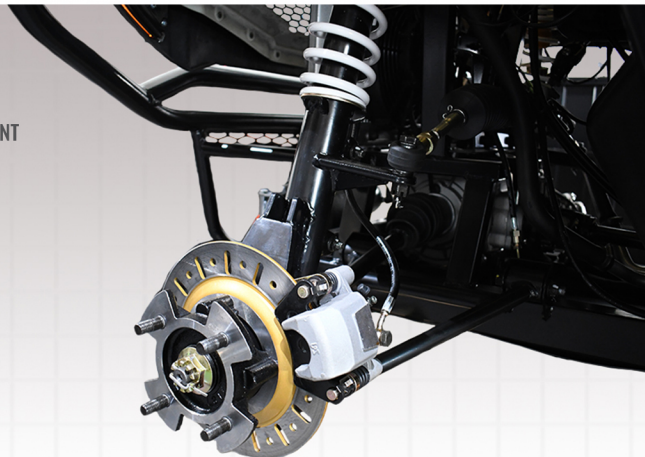

ADDITIONAL FEATURES

- WARRANTY: 1 YEAR PARTS & LABOR
- BATTERY: 12V 30AMP
- ASSEMBLED IN TEXAS, USA
- INSTRUMENTATION: DIGITAL DISPLAY, SPEEDOMETER, ODOMETER, TACHOMETER, HOUR METER, GEAR INDICATOR, 4WD INDICATOR, DIFFERENTIAL LOCK INDICATOR, TRIP METER, HEADLIGHTS (HIGH/LOW), TURN SIGNALS, 3500 LB WINCH, FUEL GAUGE, HI-TEMP





BUCK 400 X



DIMENSIONS

- VEHICLE SIZE (L X W X H): 112 IN X 56.5 IN X 74.5 IN
- WHEELBASE: 74 IN
- GROUND CLEARANCE: 9 IN
- FUEL CAPACITY: 4.8 GALLONS
- SEAT HEIGHT: 34.5 IN
- DRY WEIGHT: 1,102 LBS



4 STROKE SINGLE CYLINDER

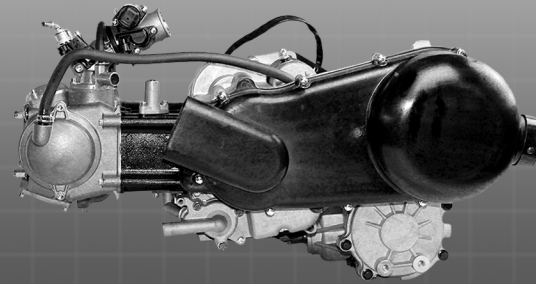

- ENGINE TYPE: FOUR STROKE SINGLE CYLINDER
- DISPLACEMENT: 391CC
- HORSEPOWER: 25 HP
- COOLING: LIQUID COOLED
- TRANSMISSION/FINAL DRIVE: AUTOMATIC CVT P/R/N/L/H, SHAFT DRIVE
- DRIVE SYSTEM: 2WD/4WD, LOCKING DIFFERENTIAL
- FUEL SYSTEM: ELECTRONIC FUEL INJECTION(EFI)

CHASSIS

- FRONT SUSPENSION: MACPHERSON INDEPENDENT
- REAR SUSPENSION: INDEPENDENT DUAL A-ARM
- FRONT TIRES: AT 25X 8-12
- REAR TIRES: AT 25X 10-12
- FRONT BRAKES: HYDRAULIC DISK BRAKES
- REAR BRAKES: HYDRAULIC DISK BRAKES

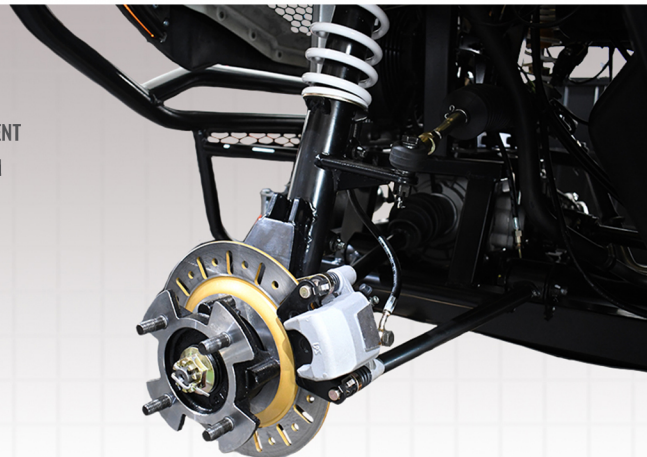

ADDITIONAL FEATURES

- WARRANTY: 1 YEAR PARTS & LABOR
- BATTERY: 12V 30AMP
- ASSEMBLED IN TEXAS, USA
- INSTRUMENTATION: DIGITAL DISPLAY, SPEEDOMETER, ODOMETER, TACHOMETER, HOUR METER, GEAR INDICATOR, 4WD INDICATOR, DIFFERENTIAL LOCK INDICATOR, TRIP METER, HEADLIGHTS (HIGH/LOW), TURN SIGNALS, 3500 LB WINCH, FUEL GAUGE, HI-TEMP





T-BOSS 410



DIMENSIONS

- VEHICLE SIZE (L X W X H): 105.5 IN X 54 IN X 74 IN
- WHEELBASE: 72 IN
- GROUND CLEARANCE: 9.75 IN
- TOWING CAPACITY: 1,200 LBS
- FUEL CAPACITY: 6.9 GALLONS
- SEAT HEIGHT: 33.5 IN
- DRY WEIGHT: 999 LBS



4 STROKE SINGLE CYLINDER

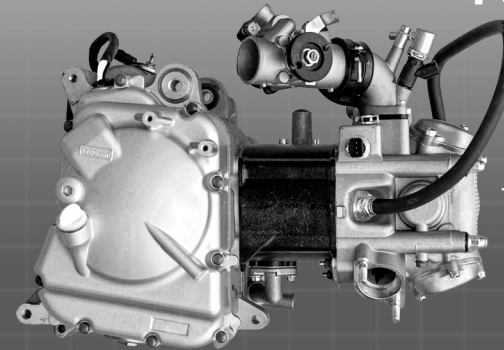

- ENGINE TYPE: FOUR STROKE SINGLE CYLINDER SOHC
- DISPLACEMENT: 352CC
- HORSEPOWER: 25.5 HP
- COOLING: LIQUID COOLED
- TRANSMISSION/FINAL DRIVE: AUTOMATIC R/N/L/H, SHAFT DRIVE
- DRIVE SYSTEM: ON DEMAND 2WD/4WD,
- FUEL SYSTEM: ELECTRONIC FUEL INJECTION(EFI)

CHASSIS

- FRONT SUSPENSION: MACPHERSON INDEPENDENT
- REAR SUSPENSION: INDEPENDENT DUAL A-ARM
- FRONT TIRES: AT 25X 8-12
- REAR TIRES: AT 25X 10-12
- FRONT BRAKES: HYDRAULIC DISK BRAKES
- REAR BRAKES: HYDRAULIC DISK BRAKES

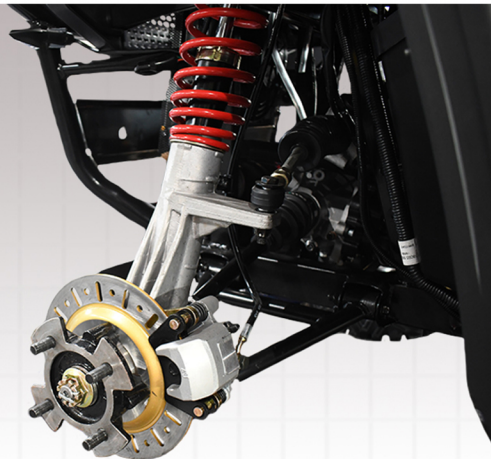

ADDITIONAL FEATURES

- WARRANTY: 1 YEAR PARTS & LABOR
- BATTERY: 12V 35AMP
- ASSEMBLED IN TEXAS, USA
- 3,000 LB WINCH, NETTED DOORS,
- FULL TILT WINDSHIELD, 2 USB PORTS
- INSTRUMENTATION: DIGITAL DISPLAY, SPEEDOMETER,
- ODOMETER, TACHOMETER, GEAR INDICATOR,
- 4WD INDICATOR, TRIP METER, LED HEAD LIGHTS,
- TURN SIGNALS, FUEL GAUGE, HI-TEMP





T-BOSS 410 X



DIMENSIONS

- VEHICLE SIZE (L X W X H): 105.5 IN X 54 IN X 74 IN
- WHEELBASE: 72 IN
- GROUND CLEARANCE: 9.75 IN
- FUEL CAPACITY: 6.9 GALLONS
- SEAT HEIGHT: 33.5 IN
- DRY WEIGHT: 999 LBS



4 STROKE SINGLE CYLINDER

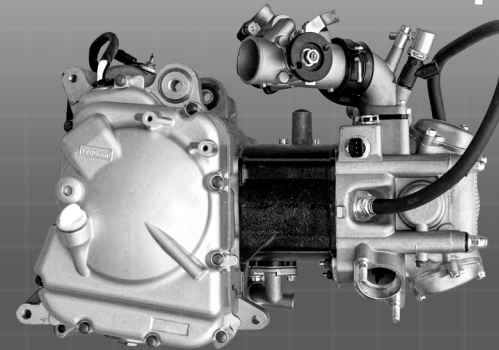

- ENGINE TYPE: FOUR STROKE SINGLE CYLINDER SOHC
- DISPLACEMENT: 352CC
- HORSEPOWER: 25.5 HP
- COOLING: LIQUID COOLED
- TRANSMISSION/FINAL DRIVE: AUTOMATIC R/N/L/H, SHAFT DRIVE
- DRIVE SYSTEM: ON DEMAND 2WD/4WD
- FUEL SYSTEM: ELECTRONIC FUEL INJECTION(EFI)

CHASSIS

- FRONT SUSPENSION: MACPHERSON INDEPENDENT
- REAR SUSPENSION: INDEPENDENT DUAL A-ARM
- FRONT TIRES: AT 25X 8-12
- REAR TIRES: AT 25X 10-12
- FRONT BRAKES: HYDRAULIC DISK BRAKES
- REAR BRAKES: HYDRAULIC DISK BRAKES

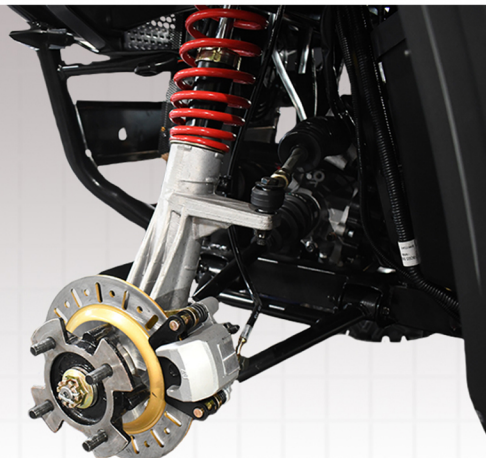

ADDITIONAL FEATURES

- WARRANTY: 1 YEAR PARTS & LABOR
- BATTERY: 12V 35AMP
- ASSEMBLED IN TEXAS, USA
- 3,000 LB WINCH, NETTED DOORS,
- FULL TILT WINDSHIELD, 2 USB PORTS
- INSTRUMENTATION: DIGITAL DISPLAY, SPEEDOMETER,
- ODOMETER, TACHOMETER, GEAR INDICATOR,
- 4WD INDICATOR, TRIP METER, LED HEAD LIGHTS,
- TURN SIGNALS, FUEL GAUGE, HI-TEMP





T-BOSS 550



DIMENSIONS

- VEHICLE SIZE (L X W X H): 103.5 IN X 54 IN X 76 IN
- WHEELBASE: 72 IN
- GROUND CLEARANCE: 9.25 IN
- TOWING CAPACITY: 1,200 LBS
- FUEL CAPACITY: 6.9 GALLONS
- SEAT HEIGHT: 33.5 IN
- DRY WEIGHT: 999 LBS



4 STROKE SINGLE CYLINDER

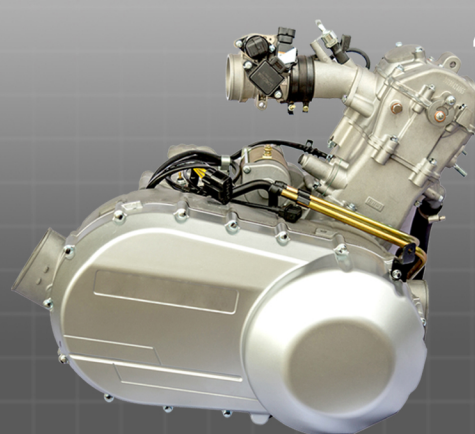

- ENGINE TYPE: FOUR STROKE SINGLE CYLINDER SOHC
- DISPLACEMENT: 493CC
- HORSEPOWER: 33 HP
- COOLING: LIQUID COOLED
- TRANSMISSION/FINAL DRIVE: AUTOMATIC CVT R/N/L/H, SHAFT DRIVE
- DRIVE SYSTEM: ON DEMAND 2WD/4WD, LOCKING DIFFERENTIAL
- FUEL SYSTEM: ELECTRONIC FUEL INJECTION(EFI)

CHASSIS

- FRONT SUSPENSION: INDEPENDENT DUAL A-ARM
- REAR SUSPENSION: INDEPENDENT DUAL A-ARM
- FRONT TIRES: AT 25X 8-12
- REAR TIRES: AT 25X 10-12
- FRONT BRAKES: HYDRAULIC DISK BRAKES
- REAR BRAKES: HYDRAULIC DISK BRAKES



ADDITIONAL FEATURES

- WARRANTY: 1 YEAR PARTS & LABOR
- BATTERY: 12V 35AMP
- ASSEMBLED IN TEXAS, USA
- 3,000 LB WINCH, NETTED DOORS,
- ADJUSTABLE TILT STEERING WHEEL, FULL TILT WIND SHIELD
- INSTRUMENTATION: DIGITAL DISPLAY, SPEEDOMETER, ODOMETER, TACHOMETER, HOUR METER, GEAR INDICATOR, 4WD INDICATOR, DIFFERENTIAL LOCK INDICATOR, TRIP METER, HEADLIGHTS (HIGH/LOW), TURN SIGNALS, FUEL GAUGE, HI-TEMP





T-BOSS 550 X



DIMENSIONS

- VEHICLE SIZE (L X W X H): 103.5 IN X 54 IN X 76 IN
- WHEELBASE: 72 IN
- GROUND CLEARANCE: 9.25 IN
- FUEL CAPACITY: 6.9 GALLONS
- SEAT HEIGHT: 33.5 IN
- DRY WEIGHT: 999 LBS



4 STROKE SINGLE CYLINDER

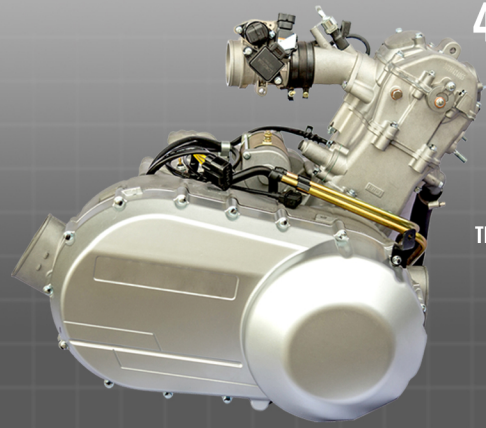

- ENGINE TYPE: FOUR STROKE SINGLE CYLINDER SOHC
- DISPLACEMENT: 493CC
- HORSEPOWER: 33 HP
- COOLING: LIQUID COOLED
- TRANSMISSION/FINAL DRIVE: AUTOMATIC CVT R/N/L/H, SHAFT DRIVE
- DRIVE SYSTEM: ON DEMAND 2WD/4WD, LOCKING DIFFERENTIAL
- FUEL SYSTEM: ELECTRONIC FUEL INJECTION(EFI)

CHASSIS

- FRONT SUSPENSION: INDEPENDENT DUAL A-ARM
- REAR SUSPENSION: INDEPENDENT DUAL A-ARM
- FRONT TIRES: AT 25X 8-12
- REAR TIRES: AT 25X 10-12
- FRONT BRAKES: HYDRAULIC DISK BRAKES
- REAR BRAKES: HYDRAULIC DISK BRAKES

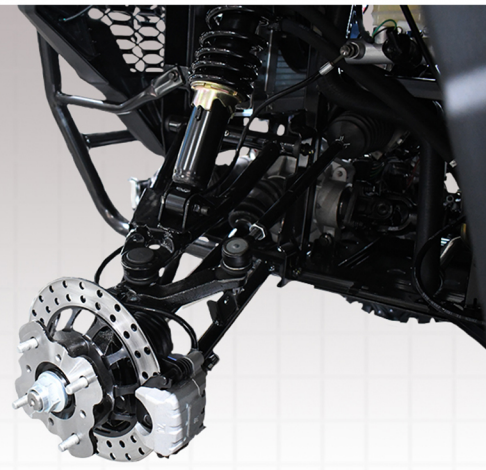

ADDITIONAL FEATURES

- WARRANTY: 1 YEAR PARTS & LABOR
- BATTERY: 12V 35AMP
- ASSEMBLED IN TEXAS, USA
- 3,000 LB WINCH, NETTED DOORS,
- ADJUSTABLE TILT STEERING WHEEL, FULL TILT WIND SHIELD
- INSTRUMENTATION: DIGITAL DISPLAY, SPEEDOMETER,
- ODOMETER, TACHOMETER, HOUR METER, GEAR INDICATOR,
- 4WD INDICATOR, DIFFERENTIAL LOCK INDICATOR,
- TRIP METER, HEADLIGHTS (HIGH/LOW), TURN SIGNALS,
- FUEL GAUGE, HI-TEMP





T-BOSS 550 F



DIMENSIONS

- VEHICLE SIZE (L X W X H): 120 IN X 58 IN X 75.6 IN
- WHEELBASE: 72 IN
- GROUND CLEARANCE: 9.25 IN
- TOWING CAPACITY: 1,200 LBS
- FUEL CAPACITY: 6.9 GALLONS
- SEAT HEIGHT: 33.5 IN
- DRY WEIGHT: 999 LBS



4 STROKE SINGLE CYLINDER

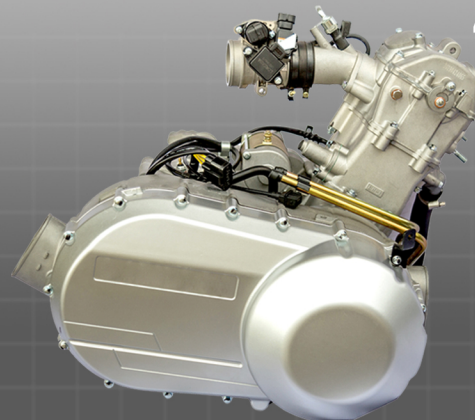

- ENGINE TYPE: FOUR STROKE SINGLE CYLINDER SOHC
- DISPLACEMENT: 493CC
- HORSEPOWER: 33 HP
- COOLING: LIQUID COOLED
- TRANSMISSION/FINAL DRIVE: AUTOMATIC CVT R/N/L/H, SHAFT DRIVE
- DRIVE SYSTEM: ON DEMAND 2WD/4WD, LOCKING DIFFERENTIAL
- FUEL SYSTEM: ELECTRONIC FUEL INJECTION(EFI)

CHASSIS

- FRONT SUSPENSION: INDEPENDENT DUAL A-ARM
- REAR SUSPENSION: INDEPENDENT DUAL A-ARM
- FRONT TIRES: AT 25X 8-12
- REAR TIRES: AT 25X 10-12
- FRONT BRAKES: HYDRAULIC DISK BRAKES
- REAR BRAKES: HYDRAULIC DISK BRAKES



ADDITIONAL FEATURES

- WARRANTY: 1 YEAR PARTS & LABOR
- BATTERY: 12V 35AMP
- ASSEMBLED IN TEXAS, USA
- 3,000 LB WINCH, NETTED DOORS,
- ADJUSTABLE TILT STEERING WHEEL, FULL TILT WIND SHIELD
- INSTRUMENTATION: DIGITAL DISPLAY, SPEEDOMETER,
- ODOMETER, TACHOMETER, HOUR METER, GEAR INDICATOR,
- 4WD INDICATOR, DIFFERENTIAL LOCK INDICATOR,
- TRIP METER, HEADLIGHTS (HIGH/LOW), TURN SIGNALS,
- FUEL GAUGE, HI-TEMP





T-BOSS 750



DIMENSIONS

- VEHICLE SIZE (L X W X H): 103.5 IN X 57 IN X 77.5 IN
- WHEELBASE: 72 IN
- GROUND CLEARANCE: 10 IN
- TOWING CAPACITY: 1,500 LBS
- FUEL CAPACITY: 6.9 GALLONS
- SEAT HEIGHT: 34 IN
- DRY WEIGHT: 999 LBS



4 STROKE SINGLE CYLINDER

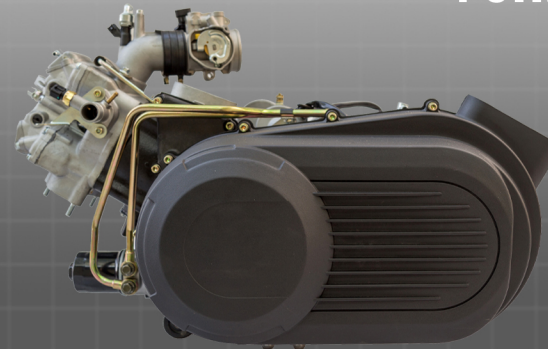

- ENGINE TYPE: FOUR STROKE SINGLE CYLINDER
- DISPLACEMENT: 694.6CC
- HORSEPOWER: 42 HP
- COOLING: LIQUID COOLED
- TRANSMISSION/FINAL DRIVE: AUTOMATIC L-H-N-R, SHAFT DRIVE
- DRIVE SYSTEM: 2WD/4WD; LOCK DIFFERENTIAL
- FUEL SYSTEM: ELECTRONIC FUEL INJECTION (EFI)

CHASSIS

- FRONT SUSPENSION: INDEPENDENT DUAL A-ARM
- REAR SUSPENSION: INDEPENDENT DUAL A-ARM
- FRONT TIRES: AT 27X 9-14
- REAR TIRES: AT 27X 11-14
- FRONT BRAKES: HYDRAULIC DISK BRAKES
- REAR BRAKES: HYDRAULIC DISK BRAKES



ADDITIONAL FEATURES

- ELECTRONIC POWER STEERING
- WARRANTY: 1 YEAR PARTS & LABOR
- BATTERY: 12V 35AMP
- ASSEMBLED IN TEXAS, USA
- INSTRUMENTATION: DIGITAL DISPLAY, SPEEDOMETER, ODOMETER, TACHOMETER, HOUR METER, GEAR INDICATOR, 4WD INDICATOR, DIFFERENTIAL LOCK INDICATOR, TRIP METER, HEADLIGHTS (HIGH/LOW), TURN SIGNALS, FUEL GAUGE, HI-TEMP





T-BOSS 750 X



DIMENSIONS

- VEHICLE SIZE (L X W X H): 103.5 IN X 57 IN X 77.5 IN
- WHEELBASE: 72 IN
- GROUND CLEARANCE: 10 IN
- FUEL CAPACITY: 6.9 GALLONS
- SEAT HEIGHT: 34 IN
- DRY WEIGHT: 999 LBS



4 STROKE SINGLE CYLINDER

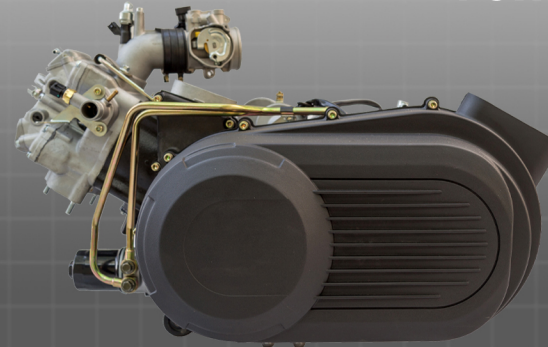

- ENGINE TYPE: FOUR STROKE SINGLE CYLINDER
- DISPLACEMENT: 694.6CC
- HORSEPOWER: 42 HP
- COOLING: LIQUID COOLED
- TRANSMISSION/FINAL DRIVE: AUTOMATIC L-H-N-R,
SHAFT DRIVE
- DRIVE SYSTEM: 2WD/4WD; LOCK DIFFERENTIAL
- FUEL SYSTEM: ELECTRONIC FUEL INJECTION (EFI)

CHASSIS

- FRONT SUSPENSION: INDEPENDENT DUAL A-ARM
- REAR SUSPENSION: INDEPENDENT DUAL A-ARM
- FRONT TIRES: AT 27X 9-14
- REAR TIRES: AT 27X 11-14
- FRONT BRAKES: HYDRAULIC DISK BRAKES
- REAR BRAKES: HYDRAULIC DISK BRAKES



ADDITIONAL FEATURES

- ELECTRONIC POWER STEERING
- WARRANTY: 1 YEAR PARTS & LABOR
- BATTERY: 12V 35AMP
- ASSEMBLED IN TEXAS, USA
- INSTRUMENTATION: DIGITAL DISPLAY, SPEEDOMETER,
ODOMETER, TACHOMETER, HOUR METER, GEAR INDICATOR,
4WD INDICATOR, DIFFERENTIAL LOCK INDICATOR,
TRIP METER, HEADLIGHTS (HIGH/LOW), TURN SIGNALS,
FUEL GAUGE, HI-TEMP





T-BOSS 1100



DIMENSIONS

- VEHICLE SIZE (L X W X H): 118.8 IN X 59.8 IN X 79.5 IN
- WHEELBASE: 76 IN
- GROUND CLEARANCE: 9.45 IN
- TOWING CAPACITY: 1,800 LBS
- FUEL CAPACITY: 9.25 GALLONS
- SEAT HEIGHT: 36.5 IN
- DRY WEIGHT: 1,543 LBS



KUBOTA DIESEL 3-CYLINDER

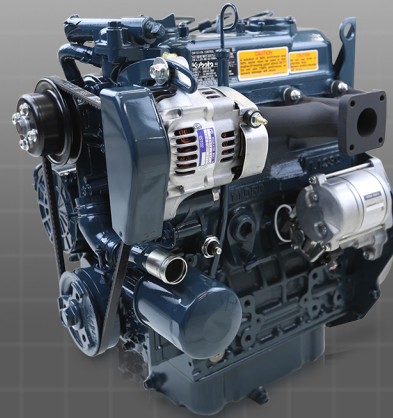

- ENGINE TYPE: KUBOTA DIESEL D1105-E3B, 3-CYLINDER
- DISPLACEMENT: 1123CC
- HORSEPOWER: 24.8 HP
- COOLING: LIQUID COOLED
- TRANSMISSION/FINAL DRIVE: AUTOMATIC L-H-N-R, SHAFT DRIVE
- DRIVE SYSTEM: ON DEMAND 2WD/4WD, LOCKING DIFFERENTIAL

CHASSIS

- FRONT SUSPENSION: INDEPENDENT DOUBLE A-ARM
- REAR SUSPENSION: INDEPENDENT DOUBLE A-ARM
- FRONT TIRES: AT 26X 9-14
- REAR TIRES: AT 26X 11-14
- FRONT BRAKES: HYDRAULIC DISK BRAKES
- REAR BRAKES: HYDRAULIC DISK BRAKES

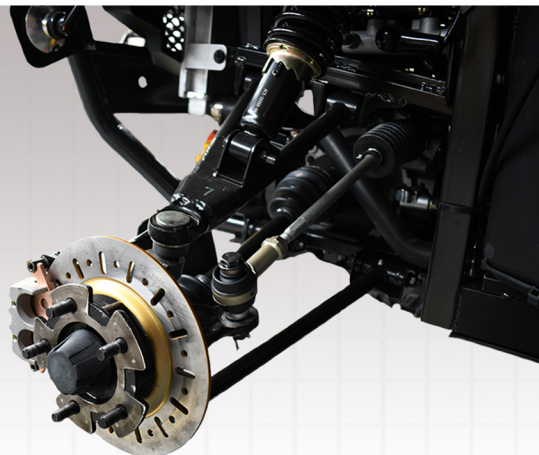

ADDITIONAL FEATURES

- ELECTRONIC POWER STEERING
- WARRANTY: 1 YEAR PARTS & LABOR
- BATTERY: 12V 35AMP
- ASSEMBLED IN TEXAS, USA
- INSTRUMENTATION: DIGITAL DISPLAY, SPEEDOMETER, ODOMETER, TACHOMETER, HOUR METER, GEAR INDICATOR, 4WD INDICATOR, DIFFERENTIAL LOCK INDICATOR, TRIP METER, HEADLIGHTS (HIGH/LOW), TURN SIGNALS, FUEL GAUGE, HI-TEMP





T-BOSS 1100 LE



DIMENSIONS

- VEHICLE SIZE (L X W X H): 118.8 IN X 59.8 IN X 79.5 IN
- WHEELBASE: 76 IN
- GROUND CLEARANCE: 9.45 IN
- TOWING CAPACITY: 1,800 LBS
- FUEL CAPACITY: 9.25 GALLONS
- SEAT HEIGHT: 36.5 IN
- DRY WEIGHT: 1,543 LBS



KUBOTA DIESEL 3-CYLINDER

- ENGINE TYPE: KUBOTA DIESEL D1105-E3B, 3-CYLINDER
- DISPLACEMENT: 1123CC
- HORSEPOWER: 24.8 HP
- COOLING: LIQUID COOLED
- TRANSMISSION/FINAL DRIVE: AUTOMATIC L-H-N-R, SHAFT DRIVE
- DRIVE SYSTEM: ON DEMAND 2WD/4WD, LOCKING DIFFERENTIAL

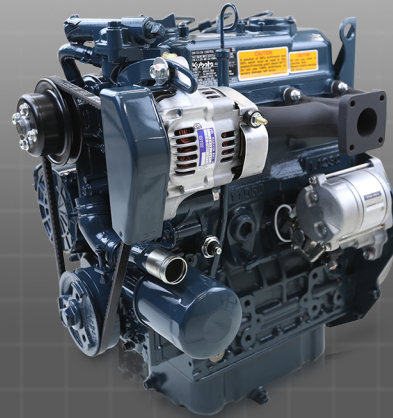

CHASSIS

- FRONT SUSPENSION: INDEPENDENT DOUBLE A-ARM
- REAR SUSPENSION: INDEPENDENT DOUBLE A-ARM
- FRONT TIRES: AT 26X 9-14
- REAR TIRES: AT 26X 11-14
- FRONT BRAKES: HYDRAULIC DISK BRAKES
- REAR BRAKES: HYDRAULIC DISK BRAKES

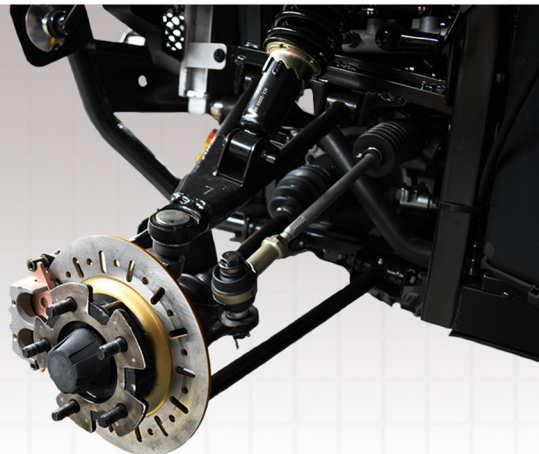

ADDITIONAL FEATURES

- ELECTRONIC POWER STEERING
- WARRANTY: 1 YEAR PARTS & LABOR
- BATTERY: 12V 35AMP
- ASSEMBLED IN TEXAS, USA
- INSTRUMENTATION: DIGITAL DISPLAY, SPEEDOMETER, ODOMETER, TACHOMETER, HOUR METER, GEAR INDICATOR, 4WD INDICATOR, DIFFERENTIAL LOCK INDICATOR, TRIP METER, HEADLIGHTS (HIGH/LOW), TURN SIGNALS, FUEL GAUGE, HI-TEMP





MSU 850



DIMENSIONS

- VEHICLE SIZE (L X W X H): 110 IN X 57 IN X 73.5 IN
- WHEELBASE: 102.5 IN
- GROUND CLEARANCE: 11 IN
- TOWING CAPACITY: 1,500 LBS
- CARGO BED CAPACITY: 660 LBS
- FUEL CAPACITY: 8 GALLONS
- SEAT HEIGHT: 32.5 IN
- DRY WEIGHT: 1,542 LBS



4 STROKE TWO CYLINDER

- ENGINE TYPE: FOUR STROKE 2 CYLINDER SOHC
- DISPLACEMENT: 800CC
- HORSEPOWER: 60 HP
- COOLING: LIQUID COOLED
- TRANSMISSION/FINAL DRIVE: AUTOMATIC CVT P/R/N/L/H, SHAFT DRIVE
- DRIVE SYSTEM: ON DEMAND 2WD/4WD, LOCKING DIFFERENTIAL
- FUEL SYSTEM: ELECTRONIC FUEL INJECTION(EFI)

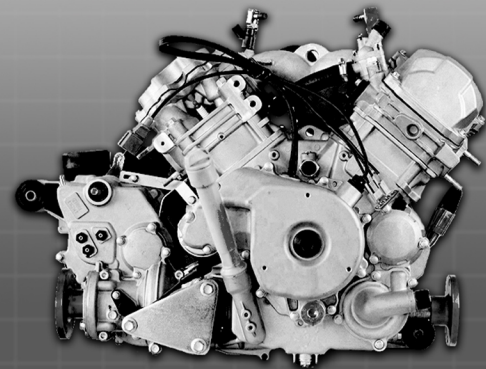

CHASSIS

- FRONT SUSPENSION: INDEPENDENT DUAL A-ARM
- REAR SUSPENSION: INDEPENDENT DUAL A-ARM
- FRONT TIRES: AT 25X 8-12
- REAR TIRES: AT 25X 10-12
- FRONT BRAKES: HYDRAULIC DISK BRAKES
- REAR BRAKES: HYDRAULIC DISK BRAKES
- ADJUSTABLE COILOVERS

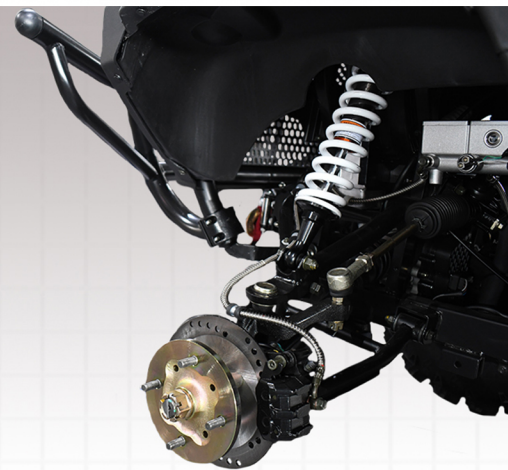

ADDITIONAL FEATURES

- ELECTRONIC POWER STEERING
- WARRANTY: 1 YEAR PARTS & LABOR
- BATTERY: 12V 35AMP
- ASSEMBLED IN TEXAS, USA
- LED LIGHT BAR, WINCH, ELECTRIC DUMP BED, DOORS, & TILT WINDSHIELD
- INSTRUMENTATION: DIGITAL DISPLAY, SPEEDOMETER, ODOMETER, TACHOMETER, HOUR METER, GEAR INDICATOR, 4WD INDICATOR, DIFFERENTIAL LOCK INDICATOR, TRIP METER, HEADLIGHTS (HIGH/LOW), TURN SIGNALS, FUEL GAUGE, HI-TEMP





MSU 850-5



DIMENSIONS

- VEHICLE SIZE (L X W X H): 137 IN X 57 IN X 73.5 IN
- WHEELBASE: 102.5 IN
- GROUND CLEARANCE: 11 IN
- TOWING CAPACITY: 1,500 LBS
- CARGO BED CAPACITY: 660 LBS
- FUEL CAPACITY: 8 GALLONS
- SEAT HEIGHT: 32.5 IN
- DRY WEIGHT: 1,542 LBS



4 STROKE TWO CYLINDER

- ENGINE TYPE: FOUR STROKE 2 CYLINDER SOHC
- DISPLACEMENT: 800CC
- HORSEPOWER: 60 HP
- COOLING: LIQUID COOLED
- TRANSMISSION/FINAL DRIVE: AUTOMATIC CVT P/R/N/L/H, SHAFT DRIVE
- DRIVE SYSTEM: ON DEMAND 2WD/4WD, LOCKING DIFFERENTIAL
- FUEL SYSTEM: ELECTRONIC FUEL INJECTION(EFI)

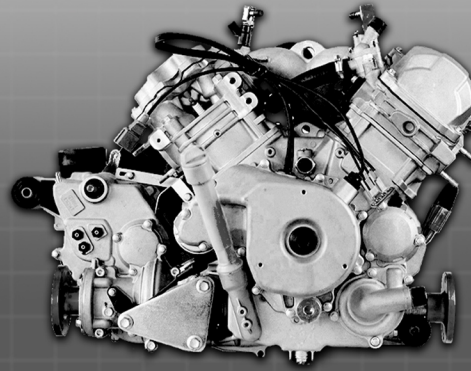

CHASSIS

- FRONT SUSPENSION: INDEPENDENT DUAL A-ARM
- REAR SUSPENSION: INDEPENDENT DUAL A-ARM
- FRONT TIRES: AT 25X 8-12
- REAR TIRES: AT 25X 10-12
- FRONT BRAKES: HYDRAULIC DISK BRAKES
- REAR BRAKES: HYDRAULIC DISK BRAKES
- ADJUSTABLE COILOVERS

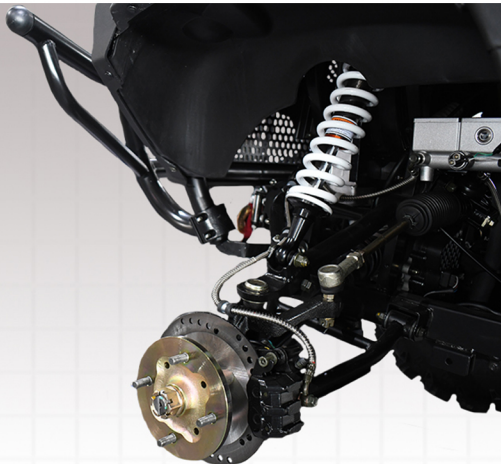

ADDITIONAL FEATURES

- ELECTRONIC POWER STEERING
- WARRANTY: 1 YEAR PARTS & LABOR
- BATTERY: 12V 35AMP
- ASSEMBLED IN TEXAS, USA
- LED LIGHT BAR, WINCH, ELECTRIC DUMP BED, DOORS, & TILT WINDSHIELD
- INSTRUMENTATION: DIGITAL DISPLAY, SPEEDOMETER, ODOMETER, TACHOMETER, HOUR METER, GEAR INDICATOR, 4WD INDICATOR, DIFFERENTIAL LOCK INDICATOR, TRIP METER, HEADLIGHTS (HIGH/LOW), TURN SIGNALS, FUEL GAUGE, HI-TEMP





WARRIOR 800



DIMENSIONS

- VEHICLE SIZE (L X W X H): 131.5 IN X 70 IN X 77 IN
- WHEELBASE: 91.5 IN
- GROUND CLEARANCE: 12.5 IN
- CARGO BED (L X W X H): 42.5 IN X 65.5 IN X 10.25 IN
- CARGO BED: HYDRAULIC PISTON DUMP
- CARGO BED CAPACITY: 500 LBS
- TOWING CAPACITY: 1,500 LBS
- FUEL CAPACITY: 12.7 GALLONS
- SEAT HEIGHT: 34.5 IN
- DRY WEIGHT: 1,830 LBS



800CC V-TWIN ENGINE

- ENGINE TYPE: FOUR STROKE 2 CYLINDER V-TWIN
- DISPLACEMENT: 800CC
- HORSEPOWER: 60 HP
- COOLING: LIQUID COOLED
- TRANSMISSION/FINAL DRIVE: AUTOMATIC CVT P/R/N/L/H, SHAFT DRIVE
- DRIVE SYSTEM: 2WD/4WD, LOCKING DIFFERENTIAL
- FUEL SYSTEM: ELECTRONIC FUEL INJECTION (EFI)

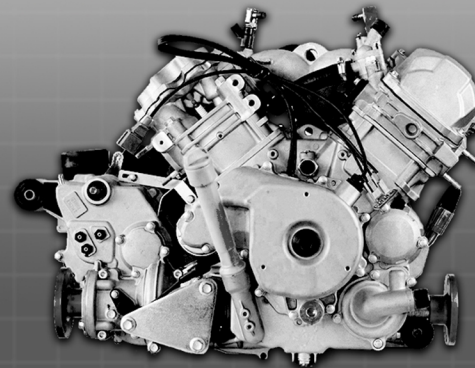

CHASSIS

- FRONT SUSPENSION: INDEPENDENT DUAL A-ARM
- REAR SUSPENSION: INDEPENDENT DUAL A-ARM
- FRONT TIRES: AT 27 X 9-14
- REAR TIRES: AT 27 X 11-14
- FRONT BRAKES: DUAL VENTILATED HYDRAULIC DISK BRAKES
- REAR BRAKES: DUAL VENTILATED HYDRAULIC DISK BRAKES
- WHEELS: ALUMINUM

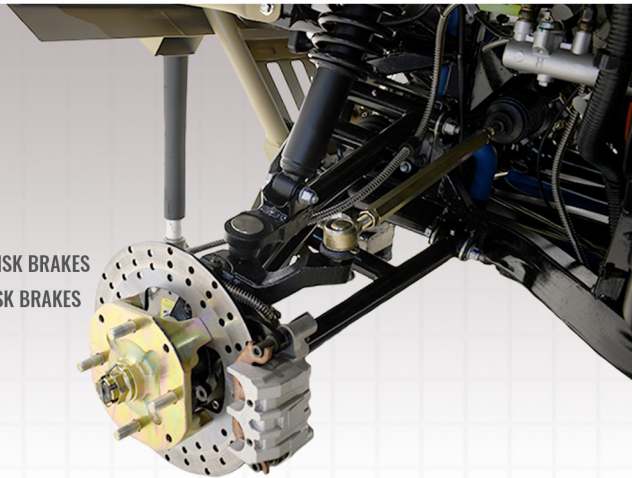

ADDITIONAL FEATURES

- ELECTRONIC POWER STEERING
- WARRANTY: 1 YEAR PARTS & LABOR
- BATTERY: 12V 35AMP
- ASSEMBLED IN TEXAS, USA
- INSTRUMENTATION: DIGITAL DISPLAY, SPEEDOMETER, ODOMETER, TACHOMETER, HOUR METER, GEAR INDICATOR, 4WD INDICATOR, DIFFERENTIAL LOCK INDICATOR, TRIP METER, HEADLIGHTS (HIGH/LOW), TURN SIGNALS, FUEL GAUGE, HI-TEMP





WARRIOR 1000



DIMENSIONS

- VEHICLE SIZE (L X W X H): 131.5 IN X 70 IN X 77 IN
- WHEELBASE: 91.5 IN
- GROUND CLEARANCE: 12.5 IN
- CARGO BED (L X W X H): 42.5 IN X 65.5 IN X 10.25 IN
- TOWING CAPACITY: 1,500 LBS
- CARGO BED CAPACITY: 500 LBS
- FUEL CAPACITY: 12.7 GALLONS
- SEAT HEIGHT: 34.5 IN
- DRY WEIGHT: 1,830 LBS



4 STROKE 2 CYLINDER V-TWIN

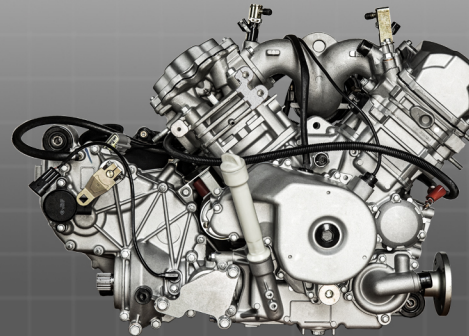

- ENGINE TYPE: FOUR STROKE 2 CYLINDER V-TWIN
- DISPLACEMENT: 1000CC
- HORSEPOWER: 85 HP
- COOLING: LIQUID COOLED
- TRANSMISSION/FINAL DRIVE: AUTOMATIC CVT P/R/N/L/H, SHAFT DRIVE
- DRIVE SYSTEM: 2WD/4WD, LOCKING DIFFERENTIAL
- FUEL SYSTEM: ELECTRONIC FUEL INJECTION(EFI)

CHASSIS

- FRONT SUSPENSION: INDEPENDENT DUAL A-ARM
- REAR SUSPENSION: INDEPENDENT DUAL A-ARM
- FRONT TIRES: AT 27X 9-14
- REAR TIRES: AT 27X 11-14
- FRONT BRAKES: DUAL VENTILATED HYDRAULIC DISK BRAKES
- REAR BRAKES: DUAL VENTILATED HYDRAULIC DISK BRAKES

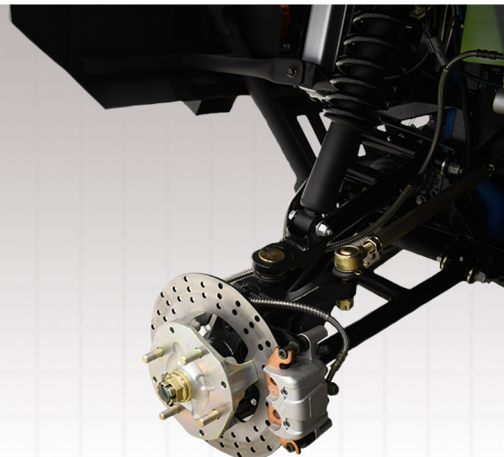

ADDITIONAL FEATURES

- ELECTRONIC POWER STEERING
- WARRANTY: 1 YEAR PARTS & LABOR
- BATTERY: 12V 35AMP
- ASSEMBLED IN TEXAS, USA
- INSTRUMENTATION: DIGITAL DISPLAY, SPEEDOMETER, ODOMETER, TACHOMETER, HOUR METER, GEAR INDICATOR, 4WD INDICATOR, DIFFERENTIAL LOCK INDICATOR, TRIP METER, HEADLIGHTS (HIGH/LOW), TURN SIGNALS, FUEL GAUGE, HI-TEMP





WARRIOR 1000 MXU

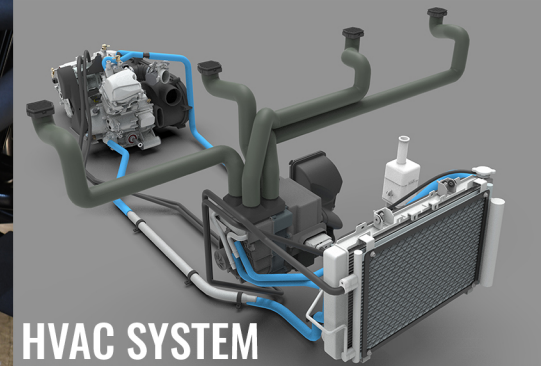

HVAC SYSTEM

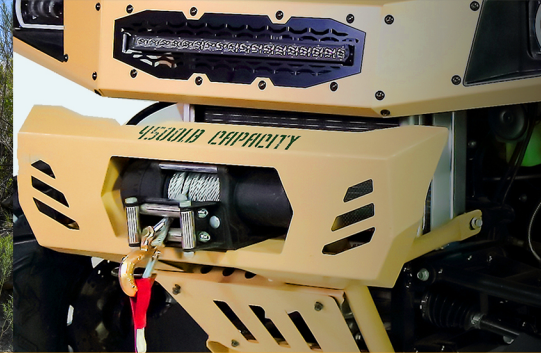

DIMENSIONS

- VEHICLE SIZE (L X W X H): 132.4 IN X 73.6 IN X 76.7 IN
- WHEELBASE: 91.5 IN
- GROUND CLEARANCE: 12.5 IN
- CARGO BED (L X W X H): 42.5 IN X 65.5 IN X 10.25 IN
- TOWING CAPACITY: 1,500 LBS
- CARGO BED CAPACITY: 500 LBS
- FUEL CAPACITY: 12.7 GALLONS
- SEAT HEIGHT: 34.5 IN
- DRY WEIGHT: 2,138 LBS



76.7" HEIGHT

4 STROKE 2 CYLINDER V-TWIN

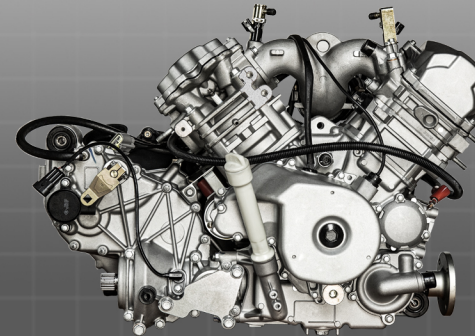

- ENGINE TYPE: FOUR STROKE 2 CYLINDER V-TWIN
- DISPLACEMENT: 1000CC
- HORSEPOWER: 85 HP
- COOLING: LIQUID COOLED
- TRANSMISSION/FINAL DRIVE: AUTOMATIC CVT P/R/N/L/H, SHAFT DRIVE
- DRIVE SYSTEM: 2WD/4WD, LOCKING DIFFERENTIAL
- FUEL SYSTEM: ELECTRONIC FUEL INJECTION(EFI)

CHASSIS

- FRONT SUSPENSION: INDEPENDENT DUAL A-ARM
- REAR SUSPENSION: INDEPENDENT DUAL A-ARM
- FRONT TIRES: AT 27X 9-14
- REAR TIRES: AT 27X 11-14
- FRONT BRAKES: DUAL VENTILATED HYDRAULIC DISK BRAKES
- REAR BRAKES: DUAL VENTILATED HYDRAULIC DISK BRAKES

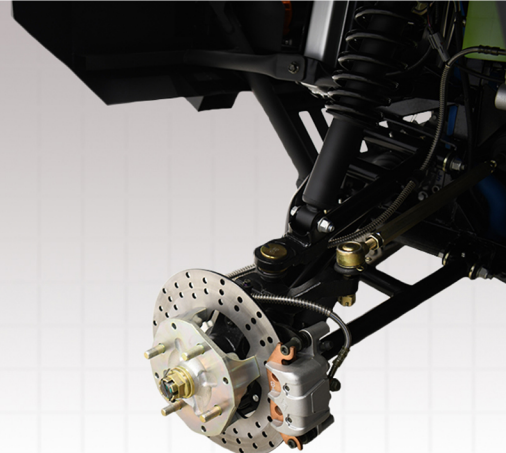

ADDITIONAL FEATURES



- ELECTRONIC POWER STEERING
- WARRANTY: 1 YEAR PARTS & LABOR
- BATTERY: 12V 35AMP
- ASSEMBLED IN TEXAS, USA
- FULLY ENCLOSED CLIMATE CONTROLLED CAB
- INSTRUMENTATION: DIGITAL DISPLAY, SPEEDOMETER, ODOMETER, TACHOMETER, HOUR METER, GEAR INDICATOR, 4WD INDICATOR, DIFFERENTIAL LOCK INDICATOR, TRIP METER, HEADLIGHTS (HIGH/LOW), TURN SIGNALS, FUEL GAUGE, HI-TEMP



WARRIOR 1000 MXU-6

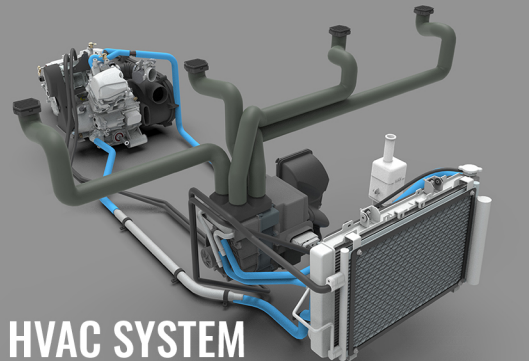

HVAC SYSTEM



DIMENSIONS

- VEHICLE SIZE (L X W X H): 163.7 IN X 75.3 IN X 76.7 IN
- WHEELBASE: 123 IN
- GROUND CLEARANCE: 12.9 IN
- CARGO BED (L X W X H): 42.5 IN X 65.5 IN X 10.25 IN
- TOWING CAPACITY: 1,500 LBS
- CARGO BED CAPACITY: 500 LBS
- FUEL CAPACITY: 12.7 GALLONS
- SEAT HEIGHT: 34.5 IN
- DRY WEIGHT: N/A



CHASSIS

- FRONT SUSPENSION: INDEPENDENT DUAL A-ARM
- REAR SUSPENSION: INDEPENDENT DUAL A-ARM
- FRONT TIRES: AT 27X 9-14
- REAR TIRES: AT 27X 11-14
- FRONT BRAKES: DUAL VENTILATED HYDRAULIC DISK BRAKES
- REAR BRAKES: DUAL VENTILATED HYDRAULIC DISK BRAKES

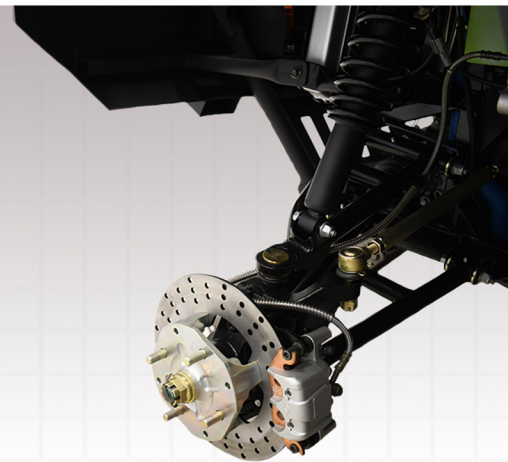

4 STROKE 2 CYLINDER V-TWIN

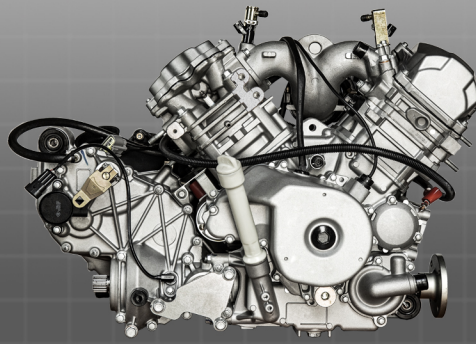

- ENGINE TYPE: FOUR STROKE 2 CYLINDER V-TWIN
- DISPLACEMENT: 1000CC
- HORSEPOWER: 85 HP
- COOLING: LIQUID COOLED
- TRANSMISSION/FINAL DRIVE: AUTOMATIC CVT P/R/N/L/H, SHAFT DRIVE
- DRIVE SYSTEM: 2WD/4WD, LOCKING DIFFERENTIAL
- FUEL SYSTEM: ELECTRONIC FUEL INJECTION(EFI)

ADDITIONAL FEATURES



- ELECTRONIC POWER STEERING
- WARRANTY: 1 YEAR PARTS & LABOR
- BATTERY: 12V 35AMP
- ASSEMBLED IN TEXAS, USA
- FULLY ENCLOSED CLIMATE CONTROLLED CAB
- INSTRUMENTATION: DIGITAL DISPLAY, SPEEDOMETER, ODOMETER, TACHOMETER, HOUR METER, GEAR INDICATOR, 4WD INDICATOR, DIFFERENTIAL LOCK INDICATOR, TRIP METER, HEADLIGHTS (HIGH/LOW), TURN SIGNALS, FUEL GAUGE, HI-TEMP



MSA 150



DIMENSIONS

- VEHICLE SIZE (L X W X H): 89 IN X 48 IN X 50 IN
- WHEELBASE: 43.7 IN
- GROUND CLEARANCE: 8 IN
- TOWING CAPACITY: N/A
- FUEL CAPACITY: 2.65 GALLONS
- SEAT HEIGHT: 38 IN
- DRY WEIGHT: 418.9 LBS



4 STROKE SINGLE CYLINDER

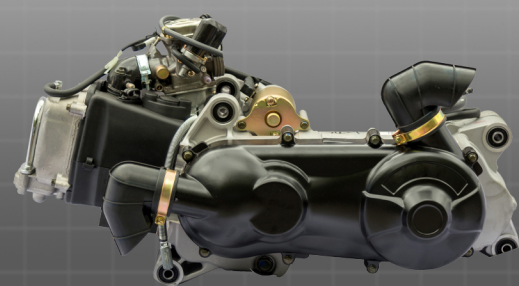

- ENGINE TYPE: FOUR STROKE SINGLE CYLINDER OHC
- DISPLACEMENT: 147.5CC
- HORSEPOWER: 7.4 HP
- COOLING: AIR COOLED
- TRANSMISSION/FINAL DRIVE: AUTOMATIC R/N/D, CVT DRIVE
- DRIVE SYSTEM: 2WD

CHASSIS

- FRONT SUSPENSION: SINGLE A-ARM
- REAR SUSPENSION: SWING ARM
- FRONT TIRES: AT 21X 7-10
- REAR TIRES: AT 22X 10-10
- FRONT BRAKES: MECHANICS DRUM BRAKES
- REAR BRAKES: HYDRAULIC DISK BRAKES

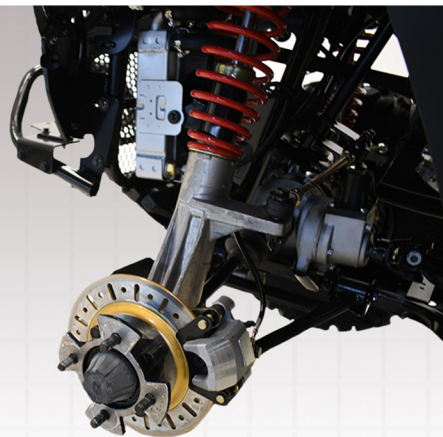

ADDITIONAL FEATURES

- ASSEMBLED IN TEXAS, USA
- INSTRUMENTATION: DIGITAL DISPLAY, SPEEDOMETER, ODOMETER, TACHOMETER, GEAR INDICATOR, DUAL TRIP METER, FUEL GAUGE, HI-TEMP





MSA 400



DIMENSIONS

- VEHICLE SIZE (L X W X H): 83 IN X 45 IN X 50 IN
- WHEELBASE: 51 IN
- GROUND CLEARANCE: 12 IN
- TOWING CAPACITY: 800 LBS
- FUEL CAPACITY: 3.8 GALLONS
- SEAT HEIGHT: 38 IN
- DRY WEIGHT: 695 LBS



4 STROKE SINGLE CYLINDER

- ENGINE TYPE: FOUR STROKE SINGLE CYLINDER
- DISPLACEMENT: 352CC
- HORSEPOWER: 25 HP
- COOLING: LIQUID COOLED
- TRANSMISSION/FINAL DRIVE: AUTOMATIC/R/N/L/H, SHAFT DRIVE
- DRIVE SYSTEM: 2WD/4WD
- FUEL SYSTEM: ELECTRONIC FUEL INJECTION(EFI)

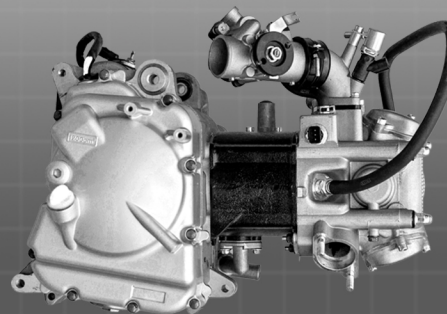

CHASSIS

- FRONT SUSPENSION: INDEPENDENT DUAL A-ARM
- REAR SUSPENSION: INDEPENDENT DUAL A-ARM
- FRONT TIRES: AT 27X 9-14
- REAR TIRES: AT 27X 11-14
- FRONT BRAKES: DUAL VENTILATED HYDRAULIC DISK BRAKES
- REAR BRAKES: DUAL VENTILATED HYDRAULIC DISK BRAKES

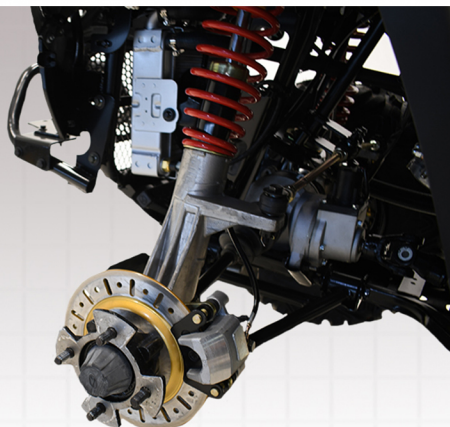

ADDITIONAL FEATURES

- WARRANTY: 1 YEAR PARTS & LABOR
- ASSEMBLED IN TEXAS, USA
- INSTRUMENTATION: DIGITAL DISPLAY, SPEEDOMETER, ODOMETER, TACHOMETER, HOUR METER, GEAR INDICATOR, 4WD INDICATOR, TRIP METER, HEADLIGHTS (HIGH/LOW), FUEL GAUGE, HI-TEMP





MSA 550



DIMENSIONS

- VEHICLE SIZE (L X W X H): 91 IN X 46 IN X 52 IN
- WHEELBASE: 57.5 IN
- GROUND CLEARANCE: 10.5 IN
- TOWING CAPACITY: 1,200 LBS
- FUEL CAPACITY: 3.8 GALLONS
- SEAT HEIGHT: 38 IN
- DRY WEIGHT: 799 LBS



4 STROKE SINGLE CYLINDER

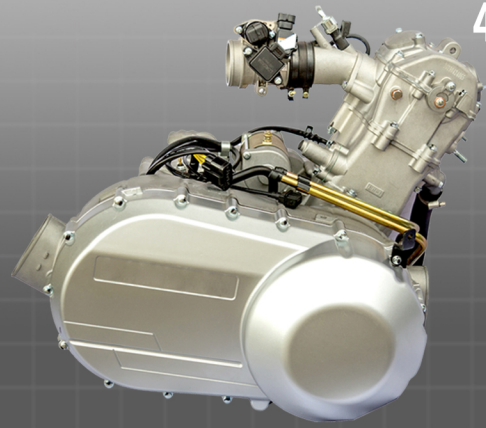

- ENGINE TYPE: FOUR STROKE SINGLE CYLINDER SOHC
- DISPLACEMENT: 493CC
- HORSEPOWER: 33 HP
- COOLING: LIQUID COOLED
- TRANSMISSION/FINAL DRIVE: AUTOMATIC R/N/L/H, SHAFT DRIVE
- DRIVE SYSTEM: ON DEMAND 2WD/4WD, LOCKING DIFFERENTIAL
- FUEL SYSTEM: ELECTRONIC FUEL INJECTION(EFI)

CHASSIS

- FRONT SUSPENSION: MACPHERSON INDEPENDENT
- REAR SUSPENSION: INDEPENDENT DUAL A-ARM
- FRONT TIRES: AT 25X 8-12
- REAR TIRES: AT 25X 10-12
- FRONT BRAKES: DUAL VENTILATED HYDRAULIC DISK BRAKES
- REAR BRAKES: DUAL VENTILATED HYDRAULIC DISK BRAKES

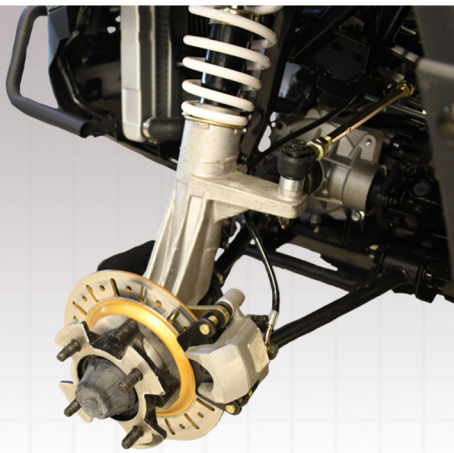

ADDITIONAL FEATURES

- ELECTRONIC POWER STEERING
- WARRANTY: 1 YEAR PARTS & LABOR
- BATTERY: 12V 35AMP
- ASSEMBLED IN TEXAS, USA
- INSTRUMENTATION: DIGITAL DISPLAY, SPEEDOMETER, ODOMETER, TACHOMETER, HOUR METER, GEAR INDICATOR, 4WD INDICATOR, DIFFERENTIAL LOCK INDICATOR, TRIP METER, HEADLIGHTS (HIGH/LOW), TURN SIGNALS, FUEL GAUGE, HI-TEMP





MSA 750



DIMENSIONS

- VEHICLE SIZE (L X W X H): 103.5 IN X 54 IN X 76 IN
- WHEELBASE: 72 IN
- GROUND CLEARANCE: 9.25 IN
- TOWING CAPACITY: 1,200 LBS
- FUEL CAPACITY: 6.9 GALLONS
- SEAT HEIGHT: 33.5 IN
- DRY WEIGHT: 999 LBS



4 STROKE SINGLE CYLINDER

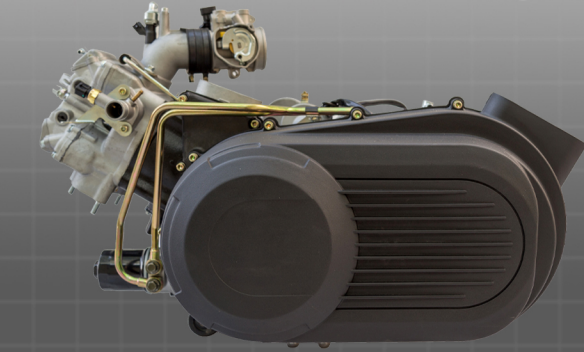

- ENGINE TYPE: FOUR STROKE SINGLE CYLINDER
- DISPLACEMENT: 694.6CC
- HORSEPOWER: 42 HP
- COOLING: LIQUID COOLED
- TRANSMISSION/FINAL DRIVE: AUTOMATIC L-H-N-R, SHAFT DRIVE
- DRIVE SYSTEM: 2WD/4WD; LOCK DIFFERENTIAL
- FUEL SYSTEM: ELECTRONIC FUEL INJECTION (EFI)

CHASSIS

- FRONT SUSPENSION: MACPHERSON INDEPENDENT
- REAR SUSPENSION: INDEPENDENT DUAL A-ARM
- FRONT TIRES: AT 25X 8-12
- REAR TIRES: AT 25X 10-12
- FRONT BRAKES: HYDRAULIC DISK BRAKES
- REAR BRAKES: HYDRAULIC DISK BRAKES

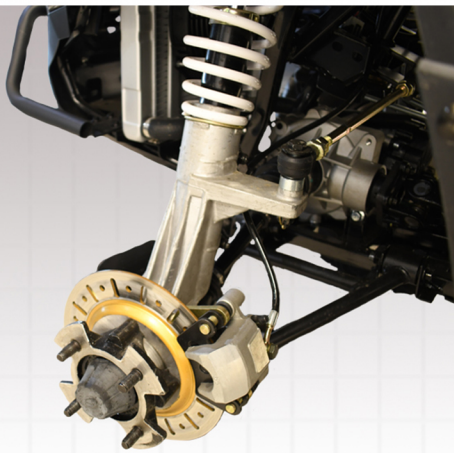

ADDITIONAL FEATURES



- ASSEMBLED IN TEXAS, USA
- INSTRUMENTATION: DIGITAL DISPLAY, SPEEDOMETER, ODOMETER, TACHOMETER, HOUR METER, GEAR INDICATOR, 4WD INDICATOR, DIFFERENTIAL LOCK INDICATOR, DUAL TRIP METER, HEADLIGHTS (HIGH/LOW), TURN SIGNALS, FUEL GAUGE, HI-TEMP, USB



125 CC GO-KART SERIES



GKM 125



GKT 125



GKG 125



DIMENSIONS

- VEHICLE SIZE (L X W X H): 74 IN X 46 IN X 51 IN
- WHEELBASE: 59 IN
- GROUND CLEARANCE: 8.5 IN
- TOWING CAPACITY: N/A
- FUEL CAPACITY: .5 GALLONS
- SEAT HEIGHT: 12 IN
- DRY WEIGHT: 281 LBS



4 STROKE SINGLE CYLINDER

- ENGINE TYPE: FOUR STROKE SINGLE CYLINDER
- DISPLACEMENT: 125CC
- BORE & STROKE: 54.5 X 54MM
- COMPRESSION RATIO: 9:1
- HORSEPOWER: 6.5 HP
- TOP SPEED: 35 MPH
- COOLING: AIR COOLED
- TRANSMISSION: AUTOMATIC W/REVERSE
- FINAL DRIVE: CHAIN DRIVE
- FUEL SYSTEM: CARBURETED
- STARTING SYSTEM: ELECTRIC
- IGNITION: CDI IGNITION

CHASSIS

- FRONT SUSPENSION: INDEPENDENT DOUBLE A-ARM
- REAR SUSPENSION: SWING ARM
- FRONT TIRES: AT 16X 8.00-7
- REAR TIRES: AT 16X 8.00-7
- FRONT BRAKE: HYDRAULIC DISC BRAKE
- REAR BRAKE: HYDRAULIC DISC BRAKE

ADDITIONAL FEATURES

- WARRANTY: 6 MONTHS LIMITED WARRANTY
- AGE LIMIT: 16 YEARS OLD
- PRODUCTION: ASSEMBLED IN TEXAS USA
- ENGINE KILL SWITCH: YES
- REMOTE CONTROL: NO
- HEADLIGHTS: YES
- TAIL LIGHTS: NO
- TURN SIGNAL INDICATOR: NO
- HORN: NO
- SPEED GOVERNOR: YES
- FOOT BRAKE: YES
- CALIFORNIA LEGALITY? NO



200CC GO-KART SERIES



GKA 200



GKM 200



GKJ 200



DIMENSIONS

- VEHICLE SIZE (L X W X H): 98 IN X 57 IN X 60 IN
- WHEELBASE: 75.5 IN
- GROUND CLEARANCE: 9 IN
- TOWING CAPACITY: N/A
- FUEL CAPACITY: 1.5 GALLONS
- SEAT HEIGHT: 14 IN
- DRY WEIGHT: 595 LBS



4 STROKE SINGLE CYLINDER

- ENGINE TYPE: FOUR STROKE SINGLE CYLINDER
- DISPLACEMENT: 200CC
- BORE & STROKE: 67.5 X 64MM
- COMPRESSION RATIO: 9.5:1
- HORSEPOWER: 9.5 HP
- TOP SPEED: 45 MPH
- COOLING: AIR COOLED
- TRANSMISSION: AUTOMATIC W/REVERSE
- FINAL DRIVE: CHAIN DRIVE
- FUEL SYSTEM: CARBURETED
- STARTING SYSTEM: ELECTRIC
- IGNITION: CDI IGNITION

CHASSIS

- FRONT SUSPENSION: INDEPENDENT SUSPENSION
- REAR SUSPENSION: SWING ARM
- FRONT TIRES: AT 27X 7.00-10
- REAR TIRES: AT 22X 11.00-10
- FRONT BRAKE: HYDRAULIC DISC BRAKE
- REAR BRAKE: HYDRAULIC DISC BRAKE

ADDITIONAL FEATURES

- WARRANTY: 6 MONTHS LIMITED WARRANTY
- AGE LIMIT: 16 YEARS OLD
- PRODUCTION: ASSEMBLED IN TEXAS USA
- FUEL GAUGE: YES
- REMOTE CONTROL: NO
- HEADLIGHTS: YES
- TAIL LIGHTS: YES
- TURN SIGNAL INDICATOR: YES
- HORN: NO
- HOUR METER: NO
- WINDSHIELD: NO
- CALIFORNIA LEGALITY? NO



MB 200 MINIBIKE



DIMENSIONS

- VEHICLE SIZE (L X W X H): 66.1 IN X 30.3 IN X 40 IN
- WHEELBASE: 36.5 IN
- GROUND CLEARANCE: 8 IN
- FUEL CAPACITY: .82 GALLONS
- SEAT HEIGHT: 24 IN
- DRY WEIGHT: 152 LBS

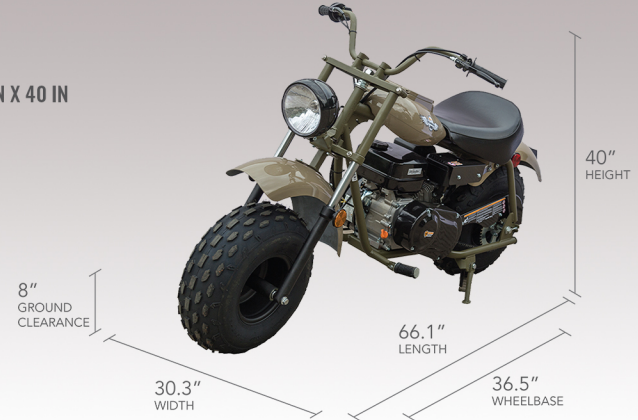

4 STROKE SINGLE CYLINDER



- ENGINE TYPE: FOUR STROKE SINGLE CYLINDER
- DISPLACEMENT: 196CC
- HORSEPOWER: 6.5 HP
- TOP SPEED: 24 MPH
- COOLING: AIR COOLED
- TRANSMISSION/FIANTL DRIVE: AUTOMATIC, CHAIN DRIVE
- DRIVE SYSTEM: CHAIN DRIVEN
- FUEL SYSTEM: CARBURETED
- IGNITION: RECOIL PULL START

CHASSIS

- FRONT SUSPENSION: HYDRAULIC TELESCOPIC
- FRONT TIRES: AT 19 X 7-8
- REAR TIRES: AT 19 X 7-8
- REAR BRAKE: DRUM BRAKE

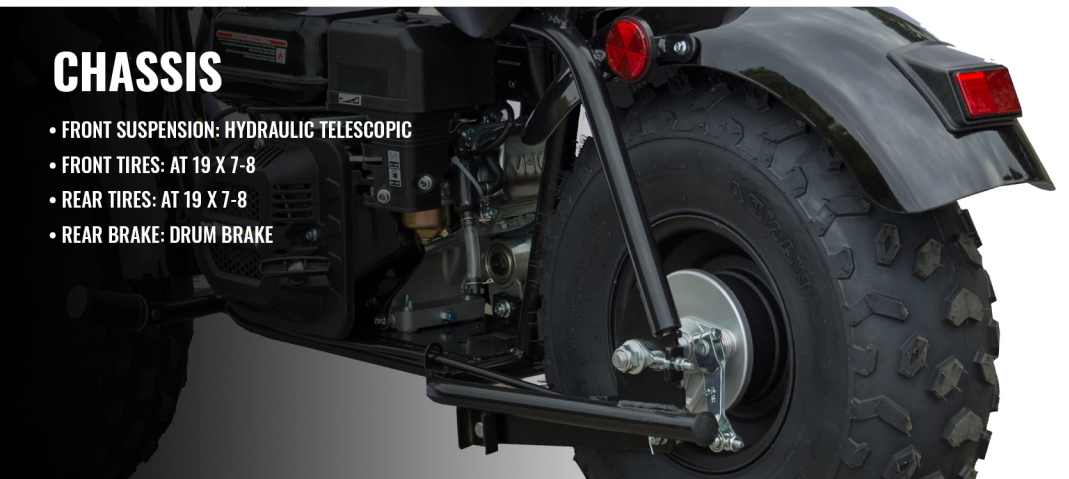

ADDITIONAL FEATURES

- HEADQUARTERED IN TEXAS, USA
- WARRANTY: 6 MONTHS PARTS & LABOR
- INCLUDES FRONT HEADLIGHT WITH SIDE AND REAR REFLECTORS





SPIDER 200



DIMENSIONS

- VEHICLE SIZE (L X W X H): 68 IN X 45 IN X 44 IN
- WHEELBASE: 46 IN
- GROUND CLEARANCE: 7 IN
- FUEL CAPACITY: 2.5 GALLONS
- SEAT HEIGHT: 31.5 IN
- DRY WEIGHT: 419 LBS



4 STROKE SINGLE CYLINDER

- ENGINE TYPE: FOUR STROKE SINGLE CYLINDER SOHC
- DISPLACEMENT: 177CC
- HORSEPOWER: 8.7 HP
- COOLING: AIR COOLED
- TRANSMISSION/FINAL DRIVE: AUTOMATIC R/N/F CHAIN DRIVE
- DRIVE SYSTEM: REAR WHEEL DRIVE
- FUEL SYSTEM: CARBURETED



CHASSIS

- FRONT SUSPENSION: INDEPENDENT DUAL A-ARM
- REAR SUSPENSION: SWING ARM
- FRONT TIRES: AT 21X 7-10
- REAR TIRES: AT 20X 10-10
- FRONT BRAKES: DRUM BRAKES
- REAR BRAKES: HYDRAULIC DISK BRAKES
- WHEELS: ALUMINUM



ADDITIONAL FEATURES

- WARRANTY: 1 YEAR PARTS & LABOR
- ASSEMBLED IN TEXAS, USA
- INSTRUMENTATION: DIGITAL GEAR INDICATOR, HEADLIGHTS, BRAKE LIGHT





MASSIMO

SNOW BLOWERS

THE **1** STOP SHOP
FOR ALL YOUR
SNOW EQUIPMENT
NEEDS



**UNIVERSAL 60 IN.
420CC UTV/ATV
SNOW BLOWER**

Engine:
4 Stroke Single Cylinder
OVH 25
Displacement:
420cc
Horsepower:
13 HP
Torque:
20 Ft./Lbs.
Bore x Stroke:
90mm x 66 mm
Compression Ratio:
8.2:1
Fuel Tank Capacities:
5.5 L, 1.45 Gallons
Enging Oil Capacities:
1.1 L, 1.16 Quarts



**34 IN. 375CC 2-STAGE
ELECTRIC START GAS
SNOW BLOWER**

Engine:
4 Stroke Single Cylinder
OVH 25
Displacement:
375cc
Max Power:
7.8 kW / 3600rpm
Torque:
23.2N.m / 2500rpm
Bore x Stroke:
85mm x 66 mm
Compression Ratio:
8.2:1
Fuel Tank Capacities:
5.5 L, 1.45 Gallons
Enging Oil Capacities:
1.1 L, 1.16 Quarts



**30 IN. 302CC 2-STAGE
ELECTRIC START GAS
SNOW BLOWER**

Engine:
4 Stroke Single Cylinder
OVH 25
Displacement:
302cc
Max Power:
6.2 kW / 3600rpm
Torque:
18.5N.m / 2500rpm
Bore x Stroke:
80mm x 60 mm
Compression Ratio:
8.2:1
Fuel Tank Capacities:
4.0L
Enging Oil Capacities:
0.95 L



**24 IN. 196CC 2-STAGE
ELECTRIC START GAS
SNOW BLOWER**

Engine:
4 Stroke Single Cylinder
OVH 25
Displacement:
196cc
Max Power:
4.4 kW / 3600rpm
Torque:
12.5N.m / 2500rpm.
Bore x Stroke:
70mm x 55 mm
Compression Ratio:
8.5:1
Fuel Tank Capacities:
3 L
Enging Oil Capacities:
0.6 L





MASSIMO

POWERFUL. AFFORDABLE. RELIABLE.



WWW.MASSIMOMOTOR.COM



@MASSIMOMOTOR



@MASSIMOMOTOR



MASSIMO MOTOR



MASSIMOMOTORSPORTS

Massimo Motor Sports, LLC

3101 W. Miller Rd. Garland, TX 75041 | (877) 881-6376 | customerservice@massimomotor.com

© 2020 Massimo Motor Sports, LLC