



MASSIMO

POWERFUL. AFFORDABLE. RELIABLE.



WWW.MASSIMOMOTOR.COM





BUCK 250



DIMENSIONS

- VEHICLE SIZE (L X W X H): 92 IN X 56 IN X 72 IN
- WHEELBASE: 69 IN
- GROUND CLEARANCE: 5.5 IN
- CARGO BED (L X W X H): 22 IN X 50 IN X 6.5 IN
- FUEL CAPACITY: N/A
- SEAT HEIGHT: N/A
- DRY WEIGHT: N/A



4 STROKE SINGLE CYLINDER

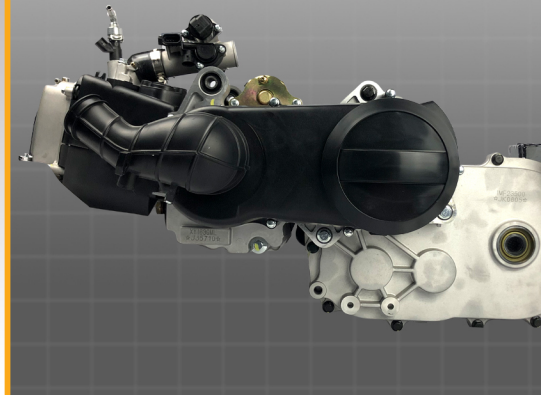

- ENGINE TYPE: FOUR STROKE SINGLE CYLINDER
- DISPLACEMENT: 177CC
- HORSEPOWER: 8.7 HP
- COOLING: AIR COOLED
- TRANSMISSION/FINAL DRIVE: CVT F/N/R,
CHAIN DRIVE
- DRIVE SYSTEM: 2WD
- FUEL SYSTEM: ELECTRONIC FUEL INJECTED

CHASSIS

- FRONT SUSPENSION: INDEPENDENT DUAL A-ARM
- REAR SUSPENSION: SWING ARM DUAL SHOCKS
- FRONT TIRES: AT 22X 7-10
- REAR TIRES: AT 22X 10-10
- FRONT BRAKES: HYDRAULIC DISK BRAKES
- REAR BRAKES: HYDRAULIC DISK BRAKES

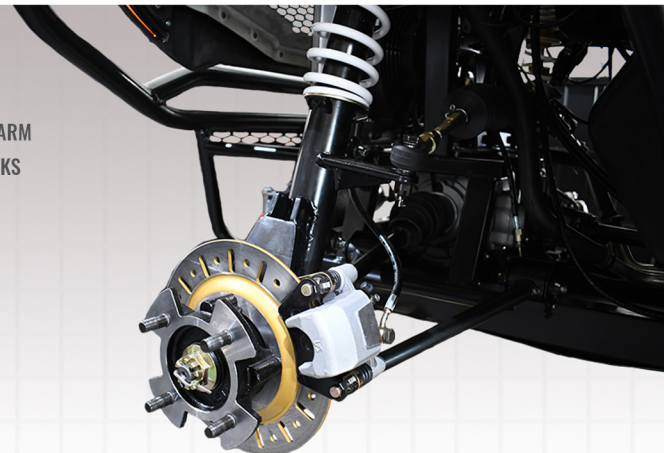

ADDITIONAL FEATURES



- WARRANTY: 1 YEAR PARTS & LABOR
- BATTERY: 12V 35AMP
- ASSEMBLED IN TEXAS, USA
- INSTRUMENTATION: DIGITAL DISPLAY, SPEEDOMETER,
ODOMETER, TACHOMETER, HOUR METER, GEAR INDICATOR,
TRIP METER, HEADLIGHTS (HIGH/LOW), TURN SIGNALS,
FUEL GAUGE, HI-TEMP



BUCK 250 X



DIMENSIONS

- VEHICLE SIZE (L X W X H): 92 IN X 56 IN X 72 IN
- WHEELBASE: 69 IN
- GROUND CLEARANCE: 5.5 IN
- CARGO BED (L X W X H): 22 IN X 50 IN X 6.5 IN
- FUEL CAPACITY: N/A
- SEAT HEIGHT: N/A
- DRY WEIGHT: N/A



4 STROKE SINGLE CYLINDER

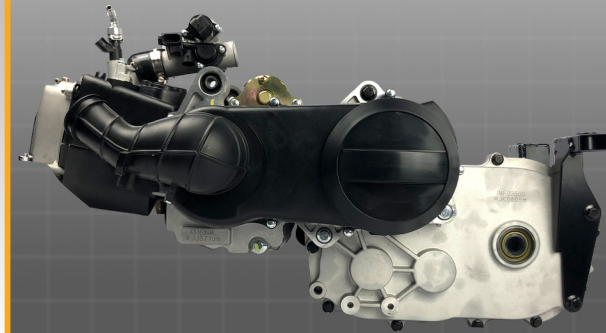

- ENGINE TYPE: FOUR STROKE SINGLE CYLINDER
- DISPLACEMENT: 177CC
- HORSEPOWER: 8.7 HP
- COOLING: AIR COOLED
- TRANSMISSION/FINAL DRIVE: CVT F/N/R,
CHAIN DRIVE
- DRIVE SYSTEM: 2WD
- FUEL SYSTEM: ELECTRONIC FUEL INJECTED

CHASSIS

- FRONT SUSPENSION: INDEPENDENT DUAL A-ARM
- REAR SUSPENSION: SWING ARM DUAL SHOCKS
- FRONT TIRES: AT 22X 7-10
- REAR TIRES: AT 22X 10-10
- FRONT BRAKES: HYDRAULIC DISK BRAKES
- REAR BRAKES: HYDRAULIC DISK BRAKES

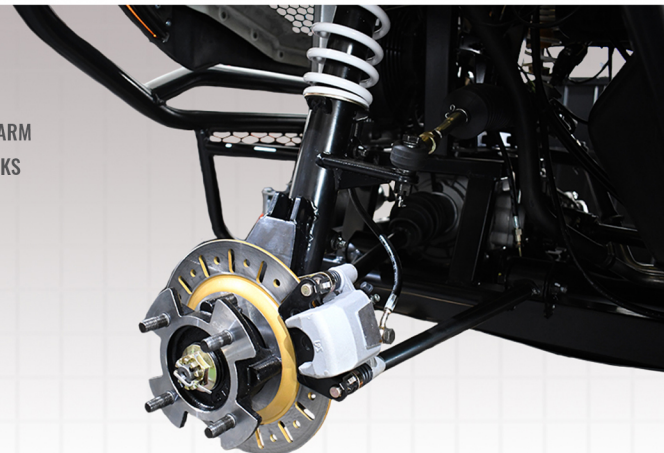

ADDITIONAL FEATURES

- WARRANTY: 1 YEAR PARTS & LABOR
- BATTERY: 12V 35AMP
- ASSEMBLED IN TEXAS, USA
- INSTRUMENTATION: DIGITAL DISPLAY, SPEEDOMETER,
ODOMETER, TACHOMETER, HOUR METER, GEAR INDICATOR,
TRIP METER, HEADLIGHTS (HIGH/LOW), TURN SIGNALS,
FUEL GAUGE, HI-TEMP





BUCK 450



DIMENSIONS

- VEHICLE SIZE (L X W X H): 108 IN X 74 IN X 73 IN
- WHEELBASE: 74 IN
- GROUND CLEARANCE: 11 IN
- TOWING CAPACITY: 1,000 LBS
- FUEL CAPACITY: N/A
- SEAT HEIGHT: 18 IN
- DRY WEIGHT: 1102 LBS



73" HEIGHT

4 STROKE SINGLE CYLINDER

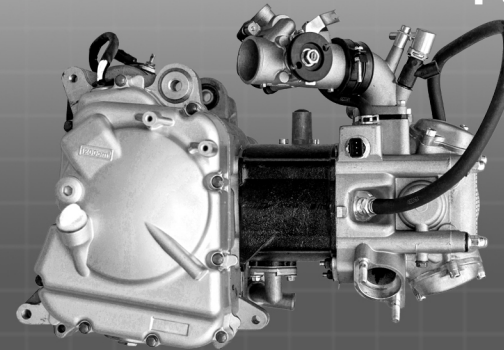

- ENGINE TYPE: FOUR STROKE SINGLE CYLINDER SOHC
- DISPLACEMENT: 352CC
- HORSEPOWER: 25.5 HP
- COOLING: LIQUID COOLED
- TRANSMISSION/FINAL DRIVE: AUTOMATIC R/N/L/H, CVT DRIVE
- DRIVE SYSTEM: ON DEMAND 2WD/4WD,
- FUEL SYSTEM: ELECTRONIC FUEL INJECTION(EFI)

CHASSIS

- FRONT SUSPENSION: INDEPENDENT DUAL A-ARM
- REAR SUSPENSION: INDEPENDENT DUAL A-ARM
- FRONT TIRES: AT 25X 8-12
- REAR TIRES: AT 25X 8-12
- FRONT BRAKES: DUAL HYDRAULIC DISK BRAKES
- REAR BRAKES: DUAL HYDRAULIC DISK BRAKES

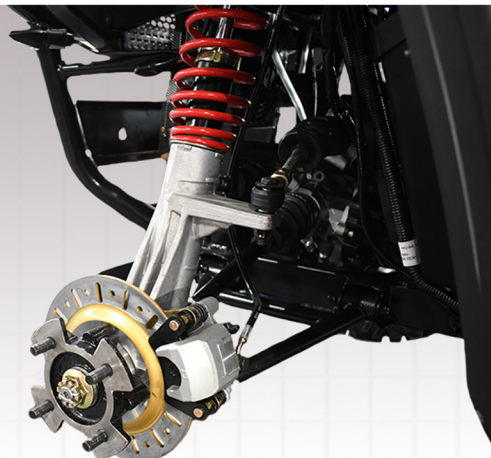

ADDITIONAL FEATURES

- WARRANTY: 1 YEAR PARTS & LABOR
- BATTERY: 12V 35AMP
- ASSEMBLED IN TEXAS, USA
- 3,000 LB WINCH, NETTED DOORS,
- FULL TILT WINDSHIELD,
- INSTRUMENTATION: DIGITAL DISPLAY, SPEEDOMETER,
- ODOMETER, TACHOMETER, GEAR INDICATOR,
- 4WD INDICATOR, TRIP METER, LED HEAD LIGHTS,
- TURN SIGNALS, FUEL GAUGE, HI-TEMP





BUCK 450 X



DIMENSIONS

- VEHICLE SIZE (L X W X H): 108 IN X 74 IN X 73 IN
- WHEELBASE: 74 IN
- GROUND CLEARANCE: 11 IN
- TOWING CAPACITY: N/A
- FUEL CAPACITY: N/A
- SEAT HEIGHT: 18 IN
- DRY WEIGHT: 1102 LBS



4 STROKE SINGLE CYLINDER

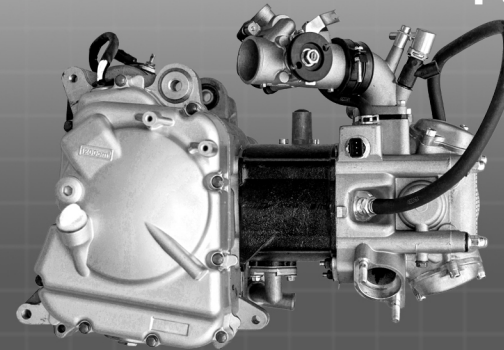

- ENGINE TYPE: FOUR STROKE SINGLE CYLINDER SOHC
- DISPLACEMENT: 352CC
- HORSEPOWER: 25.5 HP
- COOLING: LIQUID COOLED
- TRANSMISSION/FINAL DRIVE: AUTOMATIC R/N/L/H, CVT DRIVE
- DRIVE SYSTEM: ON DEMAND 2WD/4WD,
- FUEL SYSTEM: ELECTRONIC FUEL INJECTION(EFI)

CHASSIS

- FRONT SUSPENSION: INDEPENDENT DUAL A-ARM
- REAR SUSPENSION: INDEPENDENT DUAL A-ARM
- FRONT TIRES: AT 25X 8-12
- REAR TIRES: AT 25X 8-12
- FRONT BRAKES: DUAL HYDRAULIC DISK BRAKES
- REAR BRAKES: DUAL HYDRAULIC DISK BRAKES

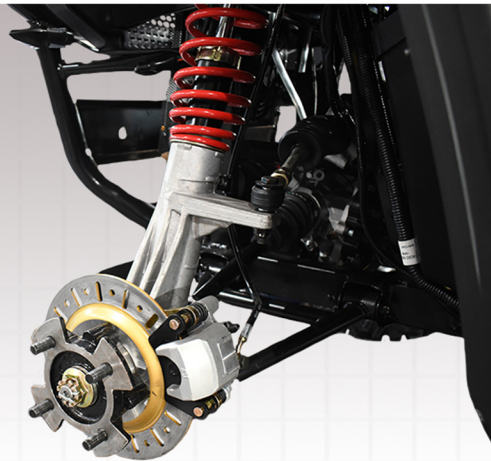

ADDITIONAL FEATURES

- WARRANTY: 1 YEAR PARTS & LABOR
- BATTERY: 12V 35AMP
- ASSEMBLED IN TEXAS, USA
- 3,000 LB WINCH, NETTED DOORS,
- FULL TILT WINDSHIELD,
- INSTRUMENTATION: DIGITAL DISPLAY, SPEEDOMETER,
- ODOMETER, TACHOMETER, GEAR INDICATOR,
- 4WD INDICATOR, TRIP METER, LED HEAD LIGHTS,
- TURN SIGNALS, FUEL GAUGE, HI-TEMP





T-BOSS 410



DIMENSIONS

- VEHICLE SIZE (L X W X H): 105.5 IN X 54 IN X 74 IN
- WHEELBASE: 72 IN
- GROUND CLEARANCE: 9.75 IN
- TOWING CAPACITY: 1,200 LBS
- FUEL CAPACITY: 6.9 GALLONS
- SEAT HEIGHT: 33.5 IN
- DRY WEIGHT: 999 LBS



4 STROKE SINGLE CYLINDER

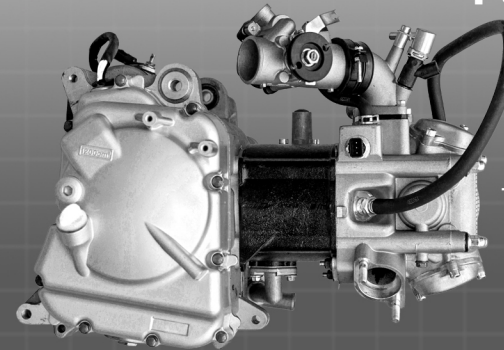

- ENGINE TYPE: FOUR STROKE SINGLE CYLINDER SOHC
- DISPLACEMENT: 352CC
- HORSEPOWER: 25.5 HP
- COOLING: LIQUID COOLED
- TRANSMISSION/FINAL DRIVE: AUTOMATIC R/N/L/H, SHAFT DRIVE
- DRIVE SYSTEM: ON DEMAND 2WD/4WD,
- FUEL SYSTEM: ELECTRONIC FUEL INJECTION(EFI)

CHASSIS

- FRONT SUSPENSION: MACPHERSON INDEPENDENT
- REAR SUSPENSION: INDEPENDENT DUAL A-ARM
- FRONT TIRES: AT 25X 8-12
- REAR TIRES: AT 25X 10-12
- FRONT BRAKES: HYDRAULIC DISK BRAKES
- REAR BRAKES: HYDRAULIC DISK BRAKES

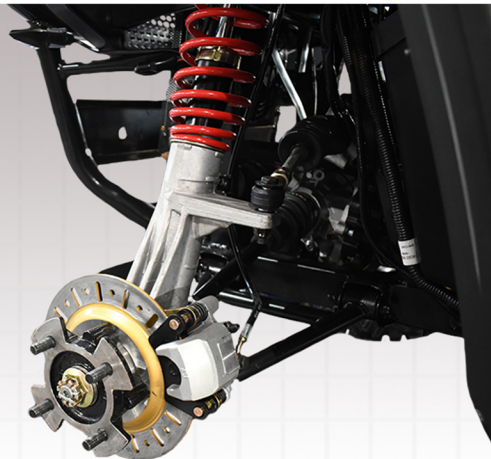

ADDITIONAL FEATURES

- WARRANTY: 1 YEAR PARTS & LABOR
- BATTERY: 12V 35AMP
- ASSEMBLED IN TEXAS, USA
- 3,000 LB WINCH, NETTED DOORS,
- FULL TILT WINDSHIELD, 2 USB PORTS
- INSTRUMENTATION: DIGITAL DISPLAY, SPEEDOMETER,
- ODOMETER, TACHOMETER, GEAR INDICATOR,
- 4WD INDICATOR, TRIP METER, LED HEAD LIGHTS,
- TURN SIGNALS, FUEL GAUGE, HI-TEMP





T-BOSS 410 X



DIMENSIONS

- VEHICLE SIZE (L X W X H): 105.5 IN X 54 IN X 74 IN
- WHEELBASE: 72 IN
- GROUND CLEARANCE: 9.75 IN
- FUEL CAPACITY: 6.9 GALLONS
- SEAT HEIGHT: 33.5 IN
- DRY WEIGHT: 999 LBS



74" HEIGHT

9.75" GROUND CLEARANCE

105.5" LENGTH

54" WIDTH

72" WHEELBASE

4 STROKE SINGLE CYLINDER

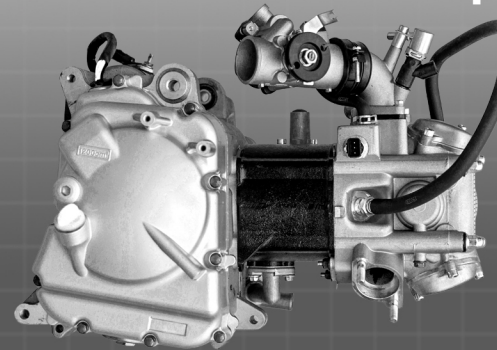

ENGINE TYPE: FOUR STROKE SINGLE CYLINDER SOHC

DISPLACEMENT: 352CC

HORSEPOWER: 25.5 HP

COOLING: LIQUID COOLED

TRANSMISSION/FINAL DRIVE: AUTOMATIC R/N/L/H, SHAFT DRIVE

DRIVE SYSTEM: ON DEMAND 2WD/4WD,

FUEL SYSTEM: ELECTRONIC FUEL INJECTION(EFI)

CHASSIS

- FRONT SUSPENSION: MACPHERSON INDEPENDENT
- REAR SUSPENSION: INDEPENDENT DUAL A-ARM
- FRONT TIRES: AT 25X 8-12
- REAR TIRES: AT 25X 10-12
- FRONT BRAKES: HYDRAULIC DISK BRAKES
- REAR BRAKES: HYDRAULIC DISK BRAKES

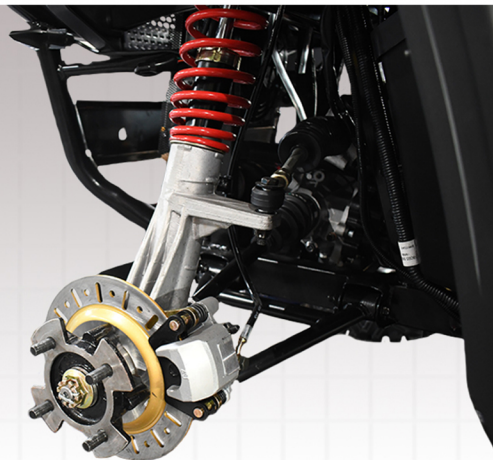

ADDITIONAL FEATURES

WARRANTY: 1 YEAR PARTS & LABOR

BATTERY: 12V 35AMP

ASSEMBLED IN TEXAS, USA

3,000 LB WINCH, NETTED DOORS,

FULL TILT WINDSHIELD, 2 USB PORTS

INSTRUMENTATION: DIGITAL DISPLAY, SPEEDOMETER,

ODOMETER, TACHOMETER, GEAR INDICATOR,

4WD INDICATOR, TRIP METER, LED HEAD LIGHTS,

TURN SIGNALS, FUEL GAUGE, HI-TEMP





T-BOSS 550



DIMENSIONS

- VEHICLE SIZE (L X W X H): 103.5 IN X 54 IN X 76 IN
- WHEELBASE: 72 IN
- GROUND CLEARANCE: 9.25 IN
- TOWING CAPACITY: 1,200 LBS
- FUEL CAPACITY: 6.9 GALLONS
- SEAT HEIGHT: 33.5 IN
- DRY WEIGHT: 999 LBS



CHASSIS

- FRONT SUSPENSION: INDEPENDENT DUAL A-ARM
- REAR SUSPENSION: INDEPENDENT DUAL A-ARM
- FRONT TIRES: AT 25X 8-12
- REAR TIRES: AT 25X 10-12
- FRONT BRAKES: HYDRAULIC DISK BRAKES
- REAR BRAKES: HYDRAULIC DISK BRAKES



4 STROKE SINGLE CYLINDER

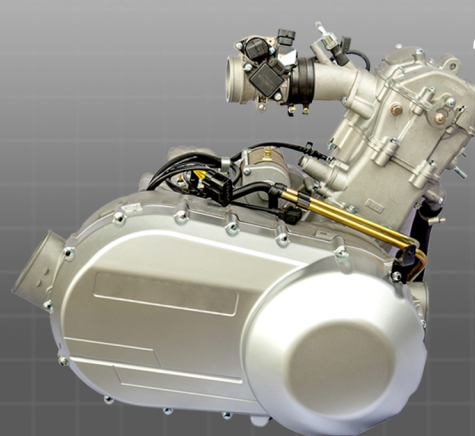

- ENGINE TYPE: FOUR STROKE SINGLE CYLINDER SOHC
- DISPLACEMENT: 493CC
- HORSEPOWER: 33 HP
- COOLING: LIQUID COOLED
- TRANSMISSION/FINAL DRIVE: AUTOMATIC CVT R/N/L/H, SHAFT DRIVE
- DRIVE SYSTEM: ON DEMAND 2WD/4WD, LOCKING DIFFERENTIAL
- FUEL SYSTEM: ELECTRONIC FUEL INJECTION(EFI)

ADDITIONAL FEATURES

- WARRANTY: 1 YEAR PARTS & LABOR
- BATTERY: 12V 35AMP
- ASSEMBLED IN TEXAS, USA
- 3,000 LB WINCH, NETTED DOORS,
- ADJUSTABLE TILT STEERING WHEEL, FULL TILT WIND SHIELD
- INSTRUMENTATION: DIGITAL DISPLAY, SPEEDOMETER, ODOMETER, TACHOMETER, HOUR METER, GEAR INDICATOR, 4WD INDICATOR, DIFFERENTIAL LOCK INDICATOR, TRIP METER, HEADLIGHTS (HIGH/LOW), TURN SIGNALS, FUEL GAUGE, HI-TEMP





T-BOSS 550 X



DIMENSIONS

- VEHICLE SIZE (L X W X H): 103.5 IN X 54 IN X 76 IN
- WHEELBASE: 72 IN
- GROUND CLEARANCE: 9.25 IN
- FUEL CAPACITY: 6.9 GALLONS
- SEAT HEIGHT: 33.5 IN
- DRY WEIGHT: 999 LBS



4 STROKE SINGLE CYLINDER

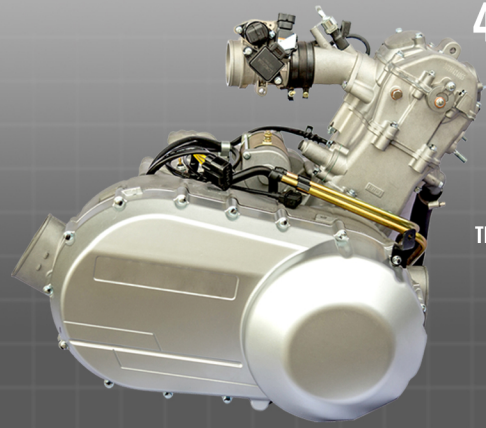

- ENGINE TYPE: FOUR STROKE SINGLE CYLINDER SOHC
- DISPLACEMENT: 493CC
- HORSEPOWER: 33 HP
- COOLING: LIQUID COOLED
- TRANSMISSION/FINAL DRIVE: AUTOMATIC CVT R/N/L/H, SHAFT DRIVE
- DRIVE SYSTEM: ON DEMAND 2WD/4WD, LOCKING DIFFERENTIAL
- FUEL SYSTEM: ELECTRONIC FUEL INJECTION(EFI)

CHASSIS

- FRONT SUSPENSION: INDEPENDENT DUAL A-ARM
- REAR SUSPENSION: INDEPENDENT DUAL A-ARM
- FRONT TIRES: AT 25X 8-12
- REAR TIRES: AT 25X 10-12
- FRONT BRAKES: HYDRAULIC DISK BRAKES
- REAR BRAKES: HYDRAULIC DISK BRAKES

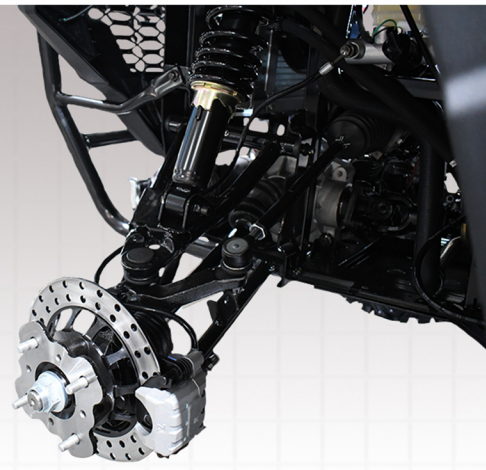

ADDITIONAL FEATURES

- WARRANTY: 1 YEAR PARTS & LABOR
- BATTERY: 12V 35AMP
- ASSEMBLED IN TEXAS, USA
- 3,000 LB WINCH, NETTED DOORS,
- ADJUSTABLE TILT STEERING WHEEL, FULL TILT WIND SHIELD
- INSTRUMENTATION: DIGITAL DISPLAY, SPEEDOMETER, ODOMETER, TACHOMETER, HOUR METER, GEAR INDICATOR, 4WD INDICATOR, DIFFERENTIAL LOCK INDICATOR, TRIP METER, HEADLIGHTS (HIGH/LOW), TURN SIGNALS, FUEL GAUGE, HI-TEMP





T-BOSS 550 F



DIMENSIONS

- VEHICLE SIZE (L X W X H): 120 IN X 58 IN X 75.6 IN
- WHEELBASE: 72 IN
- GROUND CLEARANCE: 9.25 IN
- TOWING CAPACITY: 1,200 LBS
- FUEL CAPACITY: 6.9 GALLONS
- SEAT HEIGHT: 33.5 IN
- DRY WEIGHT: 999 LBS



4 STROKE SINGLE CYLINDER

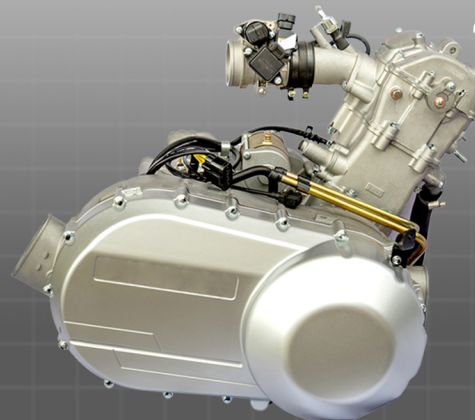

- ENGINE TYPE: FOUR STROKE SINGLE CYLINDER SOHC
- DISPLACEMENT: 493CC
- HORSEPOWER: 33 HP
- COOLING: LIQUID COOLED
- TRANSMISSION/FINAL DRIVE: AUTOMATIC CVT R/N/L/H, SHAFT DRIVE
- DRIVE SYSTEM: ON DEMAND 2WD/4WD, LOCKING DIFFERENTIAL
- FUEL SYSTEM: ELECTRONIC FUEL INJECTION(EFI)

CHASSIS

- FRONT SUSPENSION: INDEPENDENT DUAL A-ARM
- REAR SUSPENSION: INDEPENDENT DUAL A-ARM
- FRONT TIRES: AT 25X 8-12
- REAR TIRES: AT 25X 10-12
- FRONT BRAKES: HYDRAULIC DISK BRAKES
- REAR BRAKES: HYDRAULIC DISK BRAKES



ADDITIONAL FEATURES

- WARRANTY: 1 YEAR PARTS & LABOR
- BATTERY: 12V 35AMP
- ASSEMBLED IN TEXAS, USA
- 3,000 LB WINCH, NETTED DOORS,
- ADJUSTABLE TILT STEERING WHEEL, FULL TILT WIND SHIELD
- INSTRUMENTATION: DIGITAL DISPLAY, SPEEDOMETER,
- ODOMETER, TACHOMETER, HOUR METER, GEAR INDICATOR,
- 4WD INDICATOR, DIFFERENTIAL LOCK INDICATOR,
- TRIP METER, HEADLIGHTS (HIGH/LOW), TURN SIGNALS,
- FUEL GAUGE, HI-TEMP





T-BOSS 750



DIMENSIONS

- VEHICLE SIZE (L X W X H): 103.5 IN X 57 IN X 77.5 IN
- WHEELBASE: 72 IN
- GROUND CLEARANCE: 10 IN
- TOWING CAPACITY: 1,500 LBS
- FUEL CAPACITY: 6.9 GALLONS
- SEAT HEIGHT: 34 IN
- DRY WEIGHT: 999 LBS



4 STROKE SINGLE CYLINDER

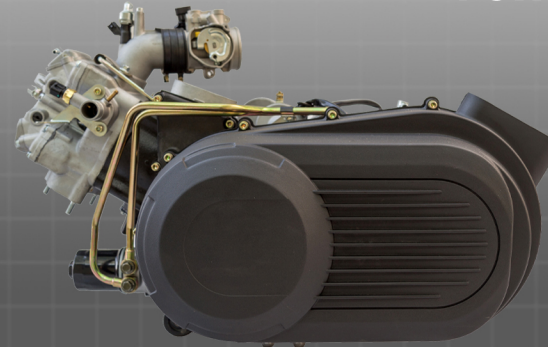

- ENGINE TYPE: FOUR STROKE SINGLE CYLINDER
- DISPLACEMENT: 694.6CC
- HORSEPOWER: 42 HP
- COOLING: LIQUID COOLED
- TRANSMISSION/FINAL DRIVE: AUTOMATIC L-H-N-R, SHAFT DRIVE
- DRIVE SYSTEM: 2WD/4WD; LOCK DIFFERENTIAL
- FUEL SYSTEM: ELECTRONIC FUEL INJECTION (EFI)

CHASSIS

- FRONT SUSPENSION: INDEPENDENT DUAL A-ARM
- REAR SUSPENSION: INDEPENDENT DUAL A-ARM
- FRONT TIRES: AT 27X 9-14
- REAR TIRES: AT 27X 11-14
- FRONT BRAKES: HYDRAULIC DISK BRAKES
- REAR BRAKES: HYDRAULIC DISK BRAKES



ADDITIONAL FEATURES

- ELECTRONIC POWER STEERING
- WARRANTY: 1 YEAR PARTS & LABOR
- BATTERY: 12V 35AMP
- ASSEMBLED IN TEXAS, USA
- INSTRUMENTATION: DIGITAL DISPLAY, SPEEDOMETER, ODOMETER, TACHOMETER, HOUR METER, GEAR INDICATOR, 4WD INDICATOR, DIFFERENTIAL LOCK INDICATOR, TRIP METER, HEADLIGHTS (HIGH/LOW), TURN SIGNALS, FUEL GAUGE, HI-TEMP





T-BOSS 750 X



DIMENSIONS

- VEHICLE SIZE (L X W X H): 103.5 IN X 57 IN X 77.5 IN
- WHEELBASE: 72 IN
- GROUND CLEARANCE: 10 IN
- FUEL CAPACITY: 6.9 GALLONS
- SEAT HEIGHT: 34 IN
- DRY WEIGHT: 999 LBS



4 STROKE SINGLE CYLINDER

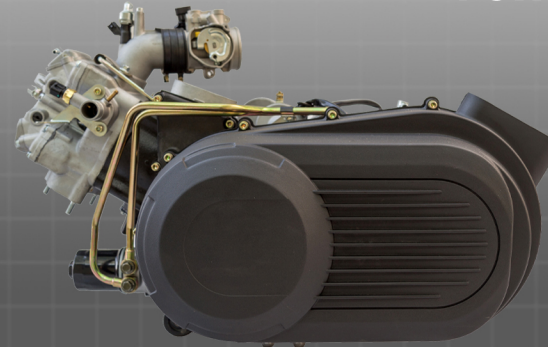

- ENGINE TYPE: FOUR STROKE SINGLE CYLINDER
- DISPLACEMENT: 694.6CC
- HORSEPOWER: 42 HP
- COOLING: LIQUID COOLED
- TRANSMISSION/FINAL DRIVE: AUTOMATIC L-H-N-R, SHAFT DRIVE
- DRIVE SYSTEM: 2WD/4WD; LOCK DIFFERENTIAL
- FUEL SYSTEM: ELECTRONIC FUEL INJECTION (EFI)

CHASSIS

- FRONT SUSPENSION: INDEPENDENT DUAL A-ARM
- REAR SUSPENSION: INDEPENDENT DUAL A-ARM
- FRONT TIRES: AT 27X 9-14
- REAR TIRES: AT 27X 11-14
- FRONT BRAKES: HYDRAULIC DISK BRAKES
- REAR BRAKES: HYDRAULIC DISK BRAKES

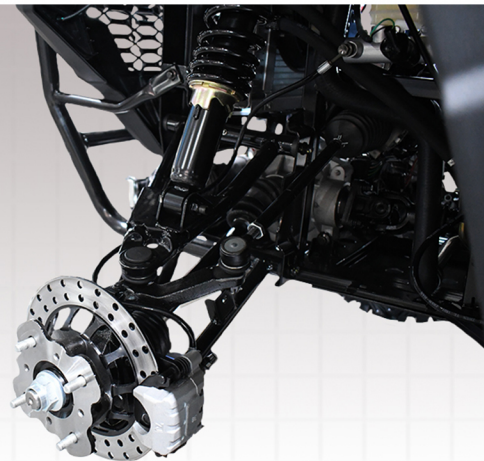

ADDITIONAL FEATURES

- ELECTRONIC POWER STEERING
- WARRANTY: 1 YEAR PARTS & LABOR
- BATTERY: 12V 35AMP
- ASSEMBLED IN TEXAS, USA
- INSTRUMENTATION: DIGITAL DISPLAY, SPEEDOMETER, ODOMETER, TACHOMETER, HOUR METER, GEAR INDICATOR, 4WD INDICATOR, DIFFERENTIAL LOCK INDICATOR, TRIP METER, HEADLIGHTS (HIGH/LOW), TURN SIGNALS, FUEL GAUGE, HI-TEMP





T-BOSS 1100



DIMENSIONS

- VEHICLE SIZE (L X W X H): 118.8 IN X 59.8 IN X 79.5 IN
- WHEELBASE: 76 IN
- GROUND CLEARANCE: 9.45 IN
- TOWING CAPACITY: 1,800 LBS
- FUEL CAPACITY: 9.25 GALLONS
- SEAT HEIGHT: 36.5 IN
- DRY WEIGHT: 1,543 LBS



KUBOTA DIESEL 3-CYLINDER

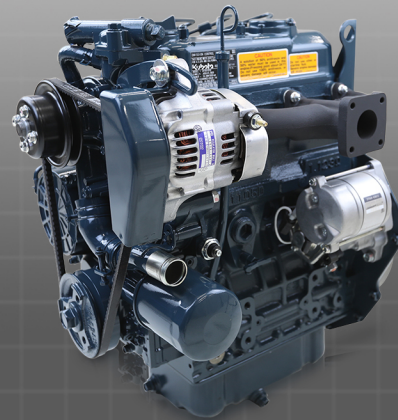

- ENGINE TYPE: KUBOTA DIESEL D1105-E3B, 3-CYLINDER
- DISPLACEMENT: 1123CC
- HORSEPOWER: 24.8 HP
- COOLING: LIQUID COOLED
- TRANSMISSION/FINAL DRIVE: AUTOMATIC L-H-N-R, SHAFT DRIVE
- DRIVE SYSTEM: ON DEMAND 2WD/4WD, LOCKING DIFFERENTIAL

CHASSIS

- FRONT SUSPENSION: INDEPENDENT DOUBLE A-ARM
- REAR SUSPENSION: INDEPENDENT DOUBLE A-ARM
- FRONT TIRES: AT 26X 9-14
- REAR TIRES: AT 26X 11-14
- FRONT BRAKES: HYDRAULIC DISK BRAKES
- REAR BRAKES: HYDRAULIC DISK BRAKES

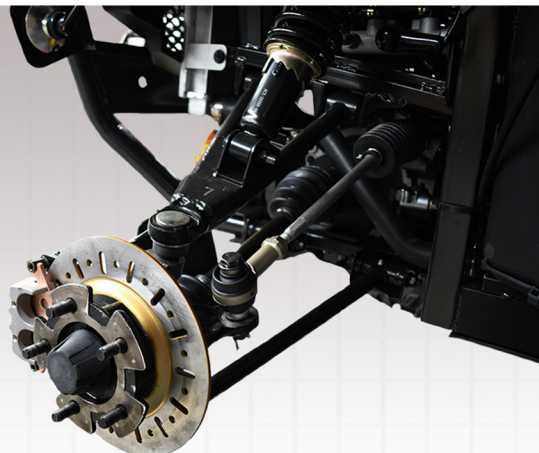

ADDITIONAL FEATURES

- ELECTRONIC POWER STEERING
- WARRANTY: 1 YEAR PARTS & LABOR
- BATTERY: 12V 35AMP
- ASSEMBLED IN TEXAS, USA
- INSTRUMENTATION: DIGITAL DISPLAY, SPEEDOMETER, ODOMETER, TACHOMETER, HOUR METER, GEAR INDICATOR, 4WD INDICATOR, DIFFERENTIAL LOCK INDICATOR, TRIP METER, HEADLIGHTS (HIGH/LOW), TURN SIGNALS, FUEL GAUGE, HI-TEMP





T-BOSS 1100 LE



DIMENSIONS

- VEHICLE SIZE (L X W X H): 118.8 IN X 59.8 IN X 79.5 IN
- WHEELBASE: 76 IN
- GROUND CLEARANCE: 9.45 IN
- TOWING CAPACITY: 1,800 LBS
- FUEL CAPACITY: 9.25 GALLONS
- SEAT HEIGHT: 36.5 IN
- DRY WEIGHT: 1,543 LBS



KUBOTA DIESEL 3-CYLINDER

- ENGINE TYPE: KUBOTA DIESEL D1105-E3B, 3-CYLINDER
- DISPLACEMENT: 1123CC
- HORSEPOWER: 24.8 HP
- COOLING: LIQUID COOLED
- TRANSMISSION/FINAL DRIVE: AUTOMATIC L-H-N-R, SHAFT DRIVE
- DRIVE SYSTEM: ON DEMAND 2WD/4WD, LOCKING DIFFERENTIAL

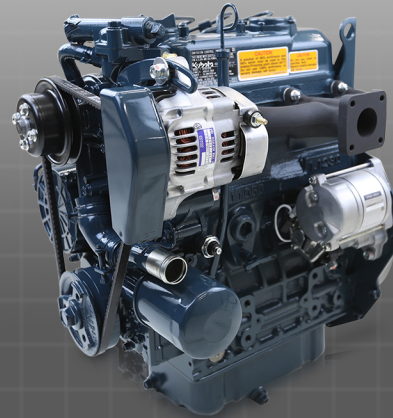

CHASSIS

- FRONT SUSPENSION: INDEPENDENT DOUBLE A-ARM
- REAR SUSPENSION: INDEPENDENT DOUBLE A-ARM
- FRONT TIRES: AT 26X 9-14
- REAR TIRES: AT 26X 11-14
- FRONT BRAKES: HYDRAULIC DISK BRAKES
- REAR BRAKES: HYDRAULIC DISK BRAKES

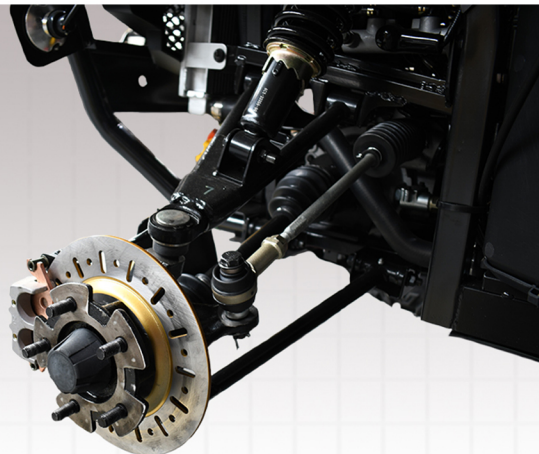

ADDITIONAL FEATURES

- ELECTRONIC POWER STEERING
- WARRANTY: 1 YEAR PARTS & LABOR
- BATTERY: 12V 35AMP
- ASSEMBLED IN TEXAS, USA
- INSTRUMENTATION: DIGITAL DISPLAY, SPEEDOMETER, ODOMETER, TACHOMETER, HOUR METER, GEAR INDICATOR, 4WD INDICATOR, DIFFERENTIAL LOCK INDICATOR, TRIP METER, HEADLIGHTS (HIGH/LOW), TURN SIGNALS, FUEL GAUGE, HI-TEMP





MSU 800



DIMENSIONS

- VEHICLE SIZE (L X W X H): 118 IN X 66 IN X 79 IN
- WHEELBASE: 64 IN
- GROUND CLEARANCE: 13 IN
- TOWING CAPACITY: 2,000 LBS
- CARGO BED CAPACITY: 660 LBS
- FUEL CAPACITY: 9 GALLONS
- SEAT HEIGHT: 39 IN
- DRY WEIGHT: 1,384 LBS



4 STROKE TWO CYLINDER

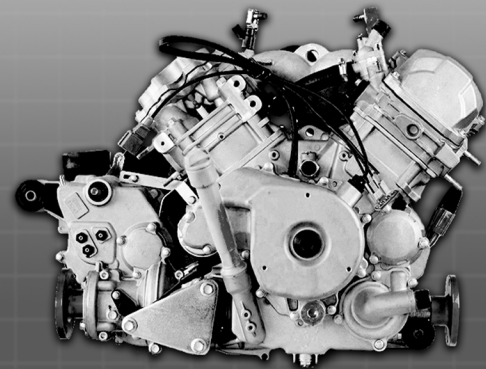

- ENGINE TYPE: V-TWIN CYLINDER 4 STROKE EFI
- DISPLACEMENT: 800CC
- HORSEPOWER: 60 HP
- COOLING: LIQUID COOLED
- TRANSMISSION/FINAL DRIVE: AUTOMATIC CVT L/H/N/R/P
- SHAFT DRIVE
- DRIVE SYSTEM: ON DEMAND 2WD/4WD, LOCKING DIFFERENTIAL
- FUEL SYSTEM: ELECTRONIC FUEL INJECTION(EFI)

CHASSIS

- FRONT SUSPENSION: INDEPENDENT DUAL A-ARM
- REAR SUSPENSION: INDEPENDENT DUAL A-ARM
- FRONT TIRES: AT 26X 9-14
- REAR TIRES: AT 26X 11-14
- FRONT BRAKES: DUAL VENTILATED DISC BRAKES W/HYDRAULIC TWIN-PISTON CALIPERS
- REAR BRAKES: DUAL VENTILATED DISC BRAKES W/HYDRAULIC TWIN-PISTON CALIPERS

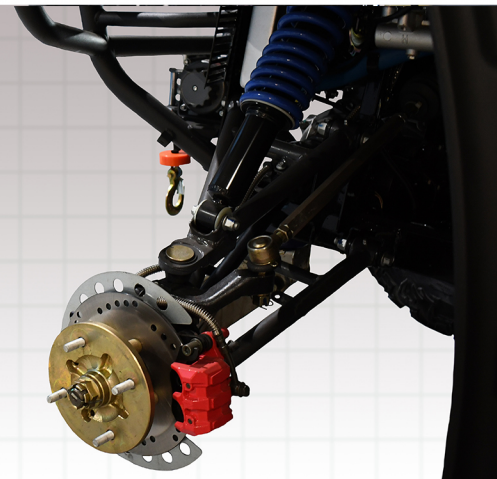

ADDITIONAL FEATURES

- WARRANTY 1 YEAR PARTS & LABOR
- WINCH: 3500LBS
- BATTERY: 12V 35AMP
- ASSEMBLED IN TEXAS, USA
- INSUTRUMENTAION: SPEEDOMETER, TACHOMETER, ODOMETER, TRIP & HOURS METERS, FUEL, GEAR INDICATION, 4X4/DIFF LOCK, DIAGNOSTIC INDICATOR, TEMPERATURE INDICATION & CLOCK





MSU 800-5



DIMENSIONS

- VEHICLE SIZE (L X W X H): 156 IN X 66 IN X 79 IN
- WHEELBASE: 64 IN
- GROUND CLEARANCE: 13 IN
- TOWING CAPACITY: 2,000 LBS
- CARGO BED CAPACITY: 660 LBS
- FUEL CAPACITY: 9 GALLONS
- SEAT HEIGHT: 39 IN
- DRY WEIGHT: 1,384 LBS



4 STROKE TWO CYLINDER

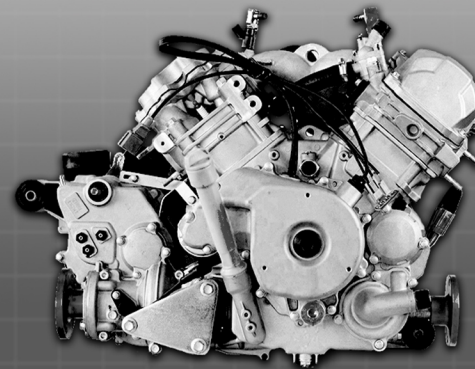

- ENGINE TYPE: V-TWIN CYLINDER 4 STROKE EFI
- DISPLACEMENT: 800CC
- HORSEPOWER: 60 HP
- COOLING: LIQUID COOLED
- TRANSMISSION/FINAL DRIVE: AUTOMATIC CVT L/H/N/R/P SHAFT DRIVE
- DRIVE SYSTEM: ON DEMAND 2WD/4WD, LOCKING DIFFERENTIAL
- FUEL SYSTEM: ELECTRONIC FUEL INJECTION(EFI)

CHASSIS

- FRONT SUSPENSION: INDEPENDENT DUAL A-ARM
- REAR SUSPENSION: INDEPENDENT DUAL A-ARM
- FRONT TIRES: AT 26X 9-14
- REAR TIRES: AT 26X 11-14
- FRONT BRAKES: DUAL VENTILATED DISC BRAKES W/HYDRAULIC TWIN-PISTON CALIPERS
- REAR BRAKES: DUAL VENTILATED DISC BRAKES W/HYDRAULIC TWIN-PISTON CALIPERS

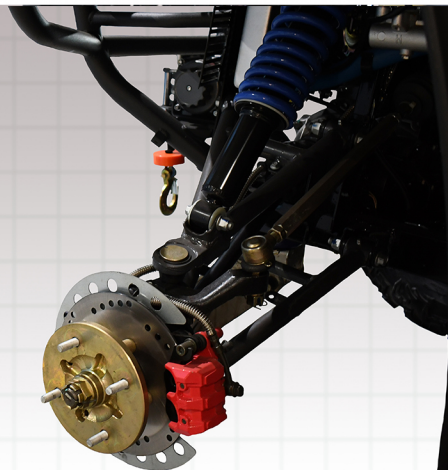

ADDITIONAL FEATURES

- WARRANTY 1 YEAR PARTS & LABOR
- WINCH: 3500LBS
- BATTERY: 12V 35AMP
- ASSEMBLED IN TEXAS, USA
- INSUTRUMENTAION: SPEEDOMETER, TACHOMETER, ODOMETER, TRIP & HOURS METERS, FUEL, GEAR INDICATION, 4X4/DIFF LOCK, DIAGNOSTIC INDICATOR, TEMPERATURE INDICATION & CLOCK





WARRIOR 800



DIMENSIONS

- VEHICLE SIZE (L X W X H): 131.5 IN X 70 IN X 77 IN
- WHEELBASE: 91.5 IN
- GROUND CLEARANCE: 12.5 IN
- CARGO BED (L X W X H): 42.5 IN X 65.5 IN X 10.25 IN
- CARGO BED: HYDRAULIC PISTON DUMP
- CARGO BED CAPACITY: 500 LBS
- TOWING CAPACITY: 2,000 LBS
- FUEL CAPACITY: 12.7 GALLONS
- SEAT HEIGHT: 34.5 IN
- DRY WEIGHT: 1,830 LBS



800CC V-TWIN ENGINE

- ENGINE TYPE: FOUR STROKE 2 CYLINDER V-TWIN
- DISPLACEMENT: 800CC
- HORSEPOWER: 60 HP
- COOLING: LIQUID COOLED
- TRANSMISSION/FINAL DRIVE: AUTOMATIC CVT P/R/N/L/H, SHAFT DRIVE
- DRIVE SYSTEM: 2WD/4WD, LOCKING DIFFERENTIAL
- FUEL SYSTEM: ELECTRONIC FUEL INJECTION (EFI)

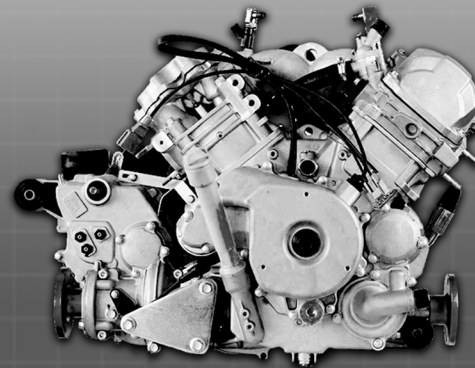

CHASSIS

- FRONT SUSPENSION: INDEPENDENT DUAL A-ARM
- REAR SUSPENSION: INDEPENDENT DUAL A-ARM
- FRONT TIRES: AT 27 X 9-14
- REAR TIRES: AT 27 X 11-14
- FRONT BRAKES: DUAL VENTILATED HYDRAULIC DISK BRAKES
- REAR BRAKES: DUAL VENTILATED HYDRAULIC DISK BRAKES
- WHEELS: ALUMINUM

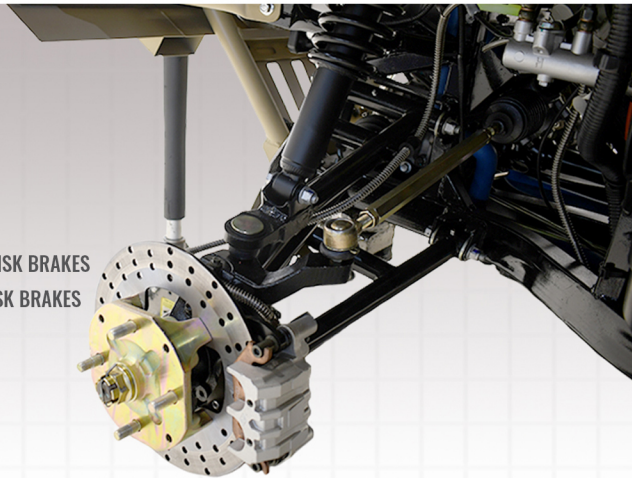

ADDITIONAL FEATURES

- ELECTRONIC POWER STEERING
- WARRANTY: 1 YEAR PARTS & LABOR
- BATTERY: 12V 35AMP
- ASSEMBLED IN TEXAS, USA
- INSTRUMENTATION: DIGITAL DISPLAY, SPEEDOMETER, ODOMETER, TACHOMETER, HOUR METER, GEAR INDICATOR, 4WD INDICATOR, DIFFERENTIAL LOCK INDICATOR, TRIP METER, HEADLIGHTS (HIGH/LOW), TURN SIGNALS, FUEL GAUGE, HI-TEMP





WARRIOR 1000



DIMENSIONS

- VEHICLE SIZE (L X W X H): 131.5 IN X 70 IN X 77 IN
- WHEELBASE: 91.5 IN
- GROUND CLEARANCE: 12.5 IN
- CARGO BED (L X W X H): 42.5 IN X 65.5 IN X 10.25 IN
- TOWING CAPACITY: 2,500 LBS
- CARGO BED CAPACITY: 500 LBS
- FUEL CAPACITY: 12.7 GALLONS
- SEAT HEIGHT: 34.5 IN
- DRY WEIGHT: 1,830 LBS



4 STROKE 2 CYLINDER V-TWIN

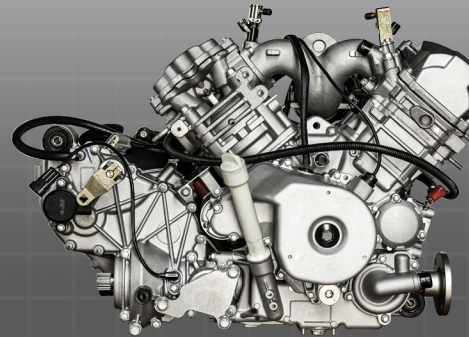

- ENGINE TYPE: FOUR STROKE 2 CYLINDER V-TWIN
- DISPLACEMENT: 1000CC
- HORSEPOWER: 85 HP
- COOLING: LIQUID COOLED
- TRANSMISSION/FINAL DRIVE: AUTOMATIC CVT P/R/N/L/H, SHAFT DRIVE
- DRIVE SYSTEM: 2WD/4WD, LOCKING DIFFERENTIAL
- FUEL SYSTEM: ELECTRONIC FUEL INJECTION(EFI)

CHASSIS

- FRONT SUSPENSION: INDEPENDENT DUAL A-ARM
- REAR SUSPENSION: INDEPENDENT DUAL A-ARM
- FRONT TIRES: AT 27X 9-14
- REAR TIRES: AT 27X 11-14
- FRONT BRAKES: DUAL VENTILATED HYDRAULIC DISK BRAKES
- REAR BRAKES: DUAL VENTILATED HYDRAULIC DISK BRAKES

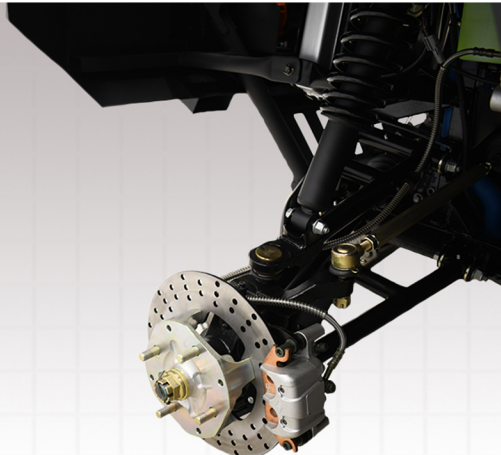

ADDITIONAL FEATURES

- ELECTRONIC POWER STEERING
- WARRANTY: 1 YEAR PARTS & LABOR
- BATTERY: 12V 35AMP
- ASSEMBLED IN TEXAS, USA
- INSTRUMENTATION: DIGITAL DISPLAY, SPEEDOMETER, ODOMETER, TACHOMETER, HOUR METER, GEAR INDICATOR, 4WD INDICATOR, DIFFERENTIAL LOCK INDICATOR, TRIP METER, HEADLIGHTS (HIGH/LOW), TURN SIGNALS, FUEL GAUGE, HI-TEMP

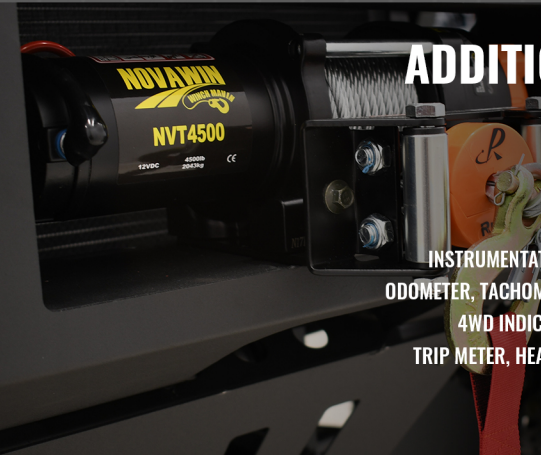



WARRIOR 1000 MXU

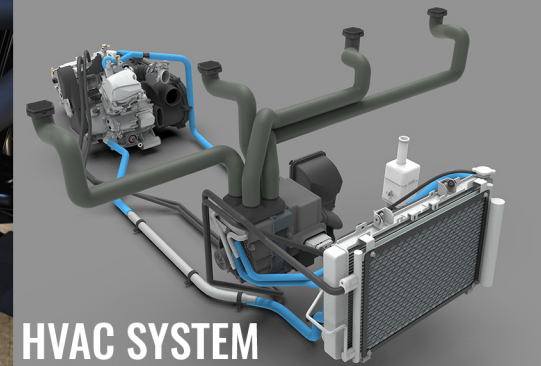

HVAC SYSTEM



DIMENSIONS

- VEHICLE SIZE (L X W X H): 132.4 IN X 73.6 IN X 76.7 IN
- WHEELBASE: 91.5 IN
- GROUND CLEARANCE: 12.5 IN
- CARGO BED (L X W X H): 42.5 IN X 65.5 IN X 10.25 IN
- TOWING CAPACITY: 2,500 LBS
- CARGO BED CAPACITY: 500 LBS
- FUEL CAPACITY: 12.7 GALLONS
- SEAT HEIGHT: 34.5 IN
- DRY WEIGHT: 2,138 LBS



CHASSIS

- FRONT SUSPENSION: INDEPENDENT DUAL A-ARM
- REAR SUSPENSION: INDEPENDENT DUAL A-ARM
- FRONT TIRES: AT 27X 9-14
- REAR TIRES: AT 27X 11-14
- FRONT BRAKES: DUAL VENTILATED HYDRAULIC DISK BRAKES
- REAR BRAKES: DUAL VENTILATED HYDRAULIC DISK BRAKES

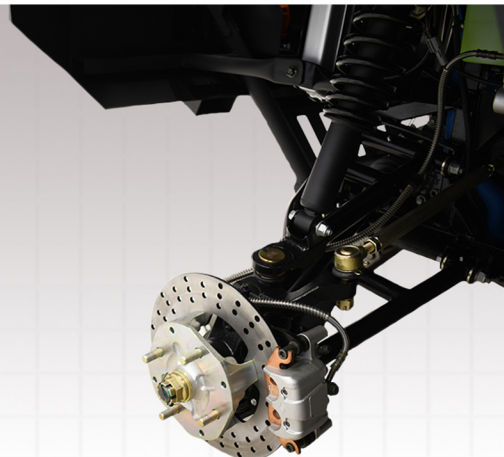

4 STROKE 2 CYLINDER V-TWIN

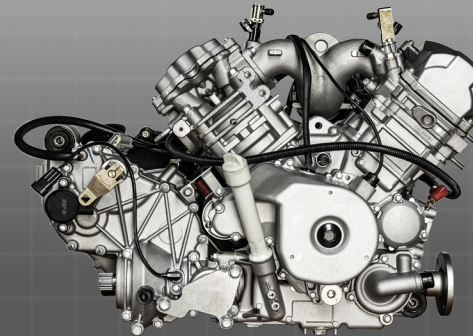

- ENGINE TYPE: FOUR STROKE 2 CYLINDER V-TWIN
- DISPLACEMENT: 1000CC
- HORSEPOWER: 85 HP
- COOLING: LIQUID COOLED
- TRANSMISSION/FINAL DRIVE: AUTOMATIC CVT P/R/N/L/H, SHAFT DRIVE
- DRIVE SYSTEM: 2WD/4WD, LOCKING DIFFERENTIAL
- FUEL SYSTEM: ELECTRONIC FUEL INJECTION(EFI)

ADDITIONAL FEATURES



- ELECTRONIC POWER STEERING
- WARRANTY: 1 YEAR PARTS & LABOR
- BATTERY: 12V 35AMP
- ASSEMBLED IN TEXAS, USA
- FULLY ENCLOSED CLIMATE CONTROLLED CAB
- INSTRUMENTATION: DIGITAL DISPLAY, SPEEDOMETER, ODOMETER, TACHOMETER, HOUR METER, GEAR INDICATOR, 4WD INDICATOR, DIFFERENTIAL LOCK INDICATOR, TRIP METER, HEADLIGHTS (HIGH/LOW), TURN SIGNALS, FUEL GAUGE, HI-TEMP



WARRIOR 1000 MXU-6

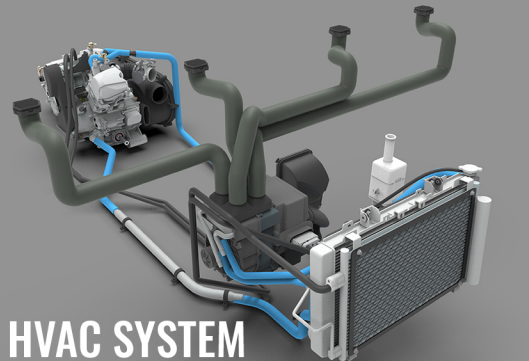

HVAC SYSTEM



DIMENSIONS

- VEHICLE SIZE (L X W X H): 163.7 IN X 75.3 IN X 76.7 IN
- WHEELBASE: 123 IN
- GROUND CLEARANCE: 12.9 IN
- CARGO BED(L X W X H): 42.5 IN X 65.5 IN X 10.25 IN
- TOWING CAPACITY: 2,500 LBS
- CARGO BED CAPACITY: 500 LBS
- FUEL CAPACITY: 12.7 GALLONS
- SEAT HEIGHT: 34.5 IN
- DRY WEIGHT: N/A



4 STROKE 2 CYLINDER V-TWIN

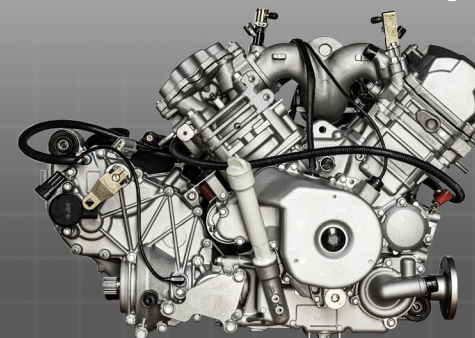

- ENGINE TYPE: FOUR STROKE 2 CYLINDER V-TWIN
- DISPLACEMENT: 1000CC
- HORSEPOWER: 85 HP
- COOLING: LIQUID COOLED
- TRANSMISSION/FINAL DRIVE: AUTOMATIC CVT P/R/N/L/H, SHAFT DRIVE
- DRIVE SYSTEM: 2WD/4WD, LOCKING DIFFERENTIAL
- FUEL SYSTEM: ELECTRONIC FUEL INJECTION(EFI)

CHASSIS

- FRONT SUSPENSION: INDEPENDENT DUAL A-ARM
- REAR SUSPENSION: INDEPENDENT DUAL A-ARM
- FRONT TIRES: AT 27X 9-14
- REAR TIRES: AT 27X 11-14
- FRONT BRAKES: DUAL VENTILATED HYDRAULIC DISK BRAKES
- REAR BRAKES: DUAL VENTILATED HYDRAULIC DISK BRAKES

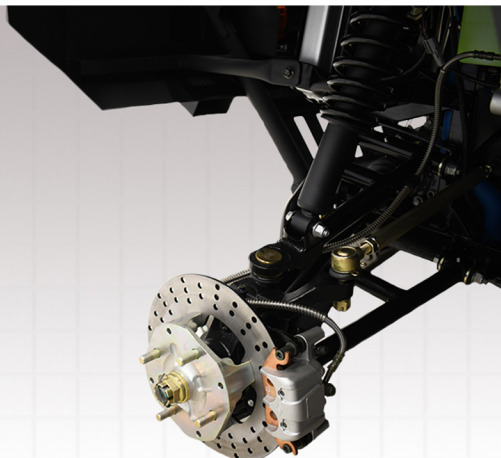

ADDITIONAL FEATURES

- ELECTRONIC POWER STEERING
- WARRANTY: 1 YEAR PARTS & LABOR
- BATTERY: 12V 35AMP
- ASSEMBLED IN TEXAS, USA
- FULLY ENCLOSED CLIMATE CONTROLLED CAB
- INSTRUMENTATION: DIGITAL DISPLAY, SPEEDOMETER, ODOMETER, TACHOMETER, HOUR METER, GEAR INDICATOR, 4WD INDICATOR, DIFFERENTIAL LOCK INDICATOR, TRIP METER, HEADLIGHTS (HIGH/LOW), TURN SIGNALS, FUEL GAUGE, HI-TEMP





MSA 150



DIMENSIONS

- VEHICLE SIZE (L X W X H): 89 IN X 48 IN X 50 IN
- WHEELBASE: 43.7 IN
- GROUND CLEARANCE: 8 IN
- TOWING CAPACITY: N/A
- FUEL CAPACITY: 2.65 GALLONS
- SEAT HEIGHT: 38 IN
- DRY WEIGHT: 418.9 LBS



37.4" HEIGHT

4 STROKE SINGLE CYLINDER

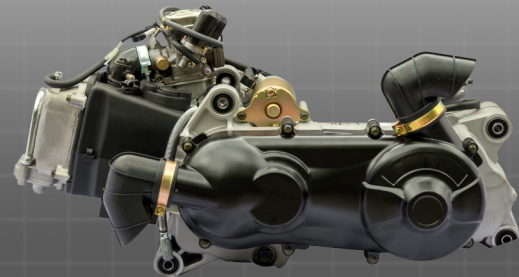

- ENGINE TYPE: FOUR STROKE SINGLE CYLINDER OHC
- DISPLACEMENT: 147.5CC
- HORSEPOWER: 7.4 HP
- COOLING: AIR COOLED
- TRANSMISSION/FINAL DRIVE: AUTOMATIC R/N/D, CVT DRIVE
- DRIVE SYSTEM: 2WD

CHASSIS

- FRONT SUSPENSION: SINGLE A-ARM
- REAR SUSPENSION: SWING ARM
- FRONT TIRES: AT 21X 7-10
- REAR TIRES: AT 22X 10-10
- FRONT BRAKES: MECHANICS DRUM BRAKES
- REAR BRAKES: HYDRAULIC DISK BRAKES

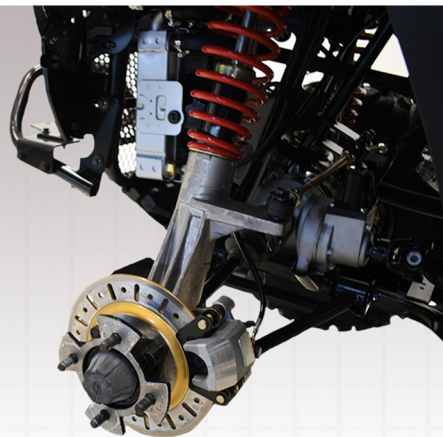

ADDITIONAL FEATURES

- ASSEMBLED IN TEXAS, USA
- INSTRUMENTATION: DIGITAL DISPLAY, SPEEDOMETER, ODOMETER, TACHOMETER, GEAR INDICATOR, DUAL TRIP METER, FUEL GAUGE, HI-TEMP





MSA 400



DIMENSIONS

- VEHICLE SIZE (L X W X H): 83 IN X 45 IN X 50 IN
- WHEELBASE: 51 IN
- GROUND CLEARANCE: 12 IN
- TOWING CAPACITY: 800 LBS
- FUEL CAPACITY: 3.8 GALLONS
- SEAT HEIGHT: 38 IN
- DRY WEIGHT: 695 LBS



CHASSIS

- FRONT SUSPENSION: INDEPENDENT DUAL A-ARM
- REAR SUSPENSION: INDEPENDENT DUAL A-ARM
- FRONT TIRES: AT 27X 9-14
- REAR TIRES: AT 27X 11-14
- FRONT BRAKES: DUAL VENTILATED HYDRAULIC DISK BRAKES
- REAR BRAKES: DUAL VENTILATED HYDRAULIC DISK BRAKES

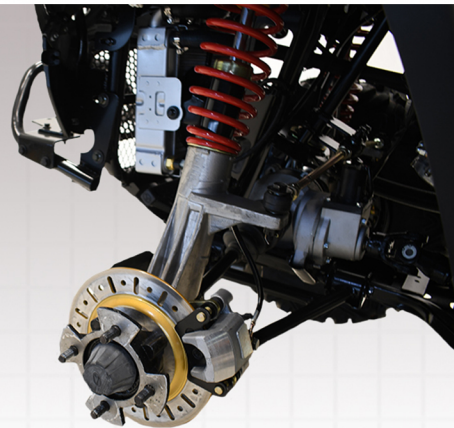

4 STROKE SINGLE CYLINDER

- ENGINE TYPE: FOUR STROKE SINGLE CYLINDER
- DISPLACEMENT: 352CC
- HORSEPOWER: 25 HP
- COOLING: LIQUID COOLED
- TRANSMISSION/FINAL DRIVE: AUTOMATIC/R/N/L/H, SHAFT DRIVE
- DRIVE SYSTEM: 2WD/4WD
- FUEL SYSTEM: ELECTRONIC FUEL INJECTION(EFI)

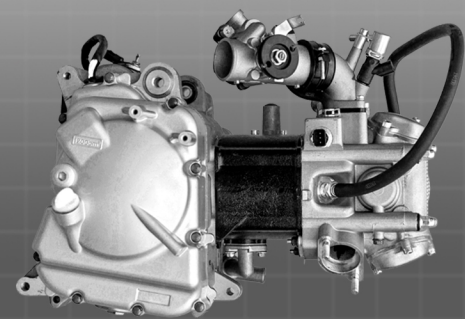

ADDITIONAL FEATURES

- WARRANTY: 1 YEAR PARTS & LABOR
- ASSEMBLED IN TEXAS, USA
- INSTRUMENTATION: DIGITAL DISPLAY, SPEEDOMETER, ODOMETER, TACHOMETER, HOUR METER, GEAR INDICATOR, 4WD INDICATOR, TRIP METER, HEADLIGHTS (HIGH/LOW), FUEL GAUGE, HI-TEMP





MSA 500



DIMENSIONS

- VEHICLE SIZE (L X W X H): 83 IN X 45 IN X 50 IN
- WHEELBASE: 51 IN
- GROUND CLEARANCE: 12 IN
- TOWING CAPACITY: 800 LBS
- FUEL CAPACITY: 3.8 GALLONS
- SEAT HEIGHT: 38 IN
- DRY WEIGHT: 695 LBS



4 STROKE SINGLE CYLINDER

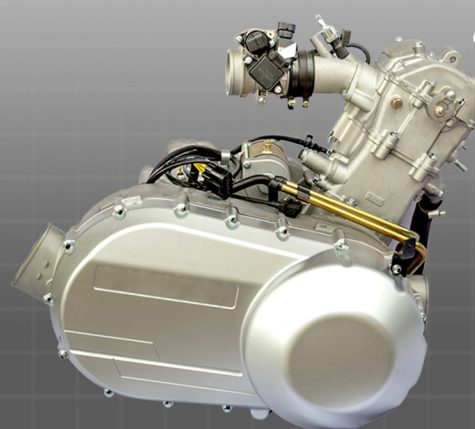

- ENGINE TYPE: FOUR STROKE SINGLE CYLINDER SOHC
- DISPLACEMENT: 493CC
- HORSEPOWER: 33 HP
- COOLING: LIQUID COOLED
- TRANSMISSION/FINAL DRIVE: AUTOMATIC R/N/L/H, SHAFT DRIVE
- DRIVE SYSTEM: ON DEMAND 2WD/4WD, LOCKING DIFFERENTIAL
- FUEL SYSTEM: ELECTRONIC FUEL INJECTION(EFI)

CHASSIS

- FRONT SUSPENSION: MACPHERSON INDEPENDENT
- REAR SUSPENSION: INDEPENDENT DUAL A-ARM
- FRONT TIRES: AT 25X 8-12
- REAR TIRES: AT 25X 10-12
- FRONT BRAKES: HYDRAULIC DISK BRAKES
- REAR BRAKES: HYDRAULIC DISK BRAKES

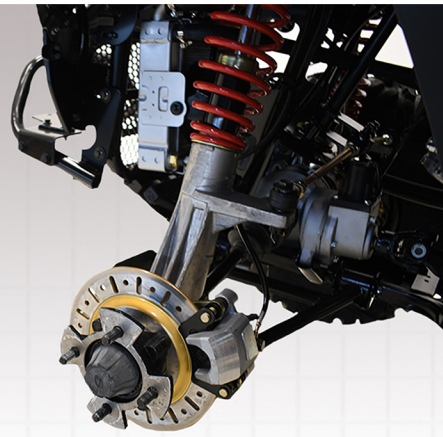

ADDITIONAL FEATURES

- ELECTRONIC POWER STEERING
- WARRANTY: 1 YEAR PARTS & LABOR
- BATTERY: 12V 35AMP
- ASSEMBLED IN TEXAS, USA
- INSTRUMENTATION: DIGITAL DISPLAY, SPEEDOMETER, ODOMETER, TACHOMETER, HOUR METER, GEAR INDICATOR, 4WD INDICATOR, DIFFERENTIAL LOCK INDICATOR, TRIP METER, HEADLIGHTS (HIGH/LOW), TURN SIGNALS, FUEL GAUGE, HI-TEMP





MSA 550 L



DIMENSIONS

- VEHICLE SIZE (L X W X H): 91 IN X 46 IN X 52 IN
- WHEELBASE: 57.5 IN
- GROUND CLEARANCE: 10.5 IN
- TOWING CAPACITY: 1,200 LBS
- FUEL CAPACITY: 3.8 GALLONS
- SEAT HEIGHT: 38 IN
- DRY WEIGHT: 799 LBS



4 STROKE SINGLE CYLINDER

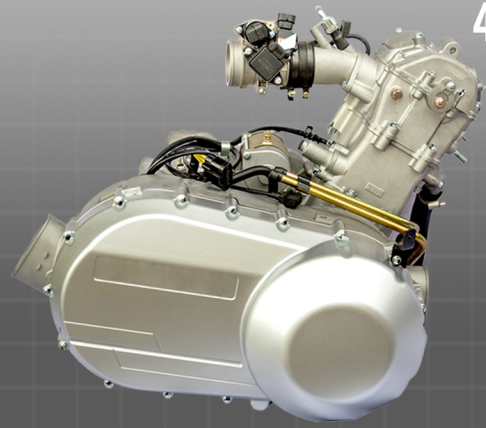

- ENGINE TYPE: FOUR STROKE SINGLE CYLINDER SOHC
- DISPLACEMENT: 493CC
- HORSEPOWER: 33 HP
- COOLING: LIQUID COOLED
- TRANSMISSION/FINAL DRIVE: AUTOMATIC R/N/L/H, SHAFT DRIVE
- DRIVE SYSTEM: ON DEMAND 2WD/4WD, LOCKING DIFFERENTIAL
- FUEL SYSTEM: ELECTRONIC FUEL INJECTION(EFI)

CHASSIS

- FRONT SUSPENSION: MACPHERSON INDEPENDENT
- REAR SUSPENSION: INDEPENDENT DUAL A-ARM
- FRONT TIRES: AT 25X 8-12
- REAR TIRES: AT 25X 10-12
- FRONT BRAKES: DUAL VENTILATED HYDRAULIC DISK BRAKES
- REAR BRAKES: DUAL VENTILATED HYDRAULIC DISK BRAKES

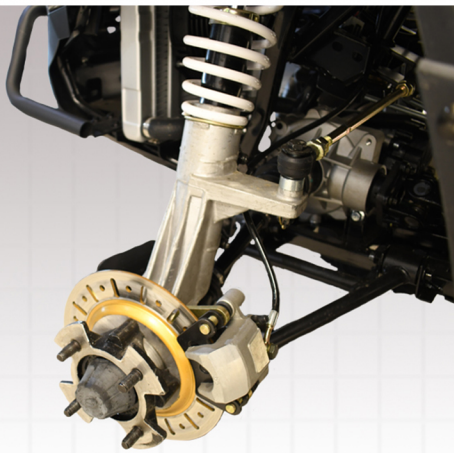

ADDITIONAL FEATURES

- ELECTRONIC POWER STEERING
- WARRANTY: 1 YEAR PARTS & LABOR
- BATTERY: 12V 35AMP
- ASSEMBLED IN TEXAS, USA
- INSTRUMENTATION: DIGITAL DISPLAY, SPEEDOMETER, ODOMETER, TACHOMETER, HOUR METER, GEAR INDICATOR, 4WD INDICATOR, DIFFERENTIAL LOCK INDICATOR, TRIP METER, HEADLIGHTS (HIGH/LOW), TURN SIGNALS, FUEL GAUGE, HI-TEMP





MSA 750



DIMENSIONS

- VEHICLE SIZE (L X W X H): 103.5 IN X 54 IN X 76 IN
- WHEELBASE: 72 IN
- GROUND CLEARANCE: 9.25 IN
- TOWING CAPACITY: 1,200 LBS
- FUEL CAPACITY: 6.9 GALLONS
- SEAT HEIGHT: 33.5 IN
- DRY WEIGHT: 999 LBS



4 STROKE SINGLE CYLINDER

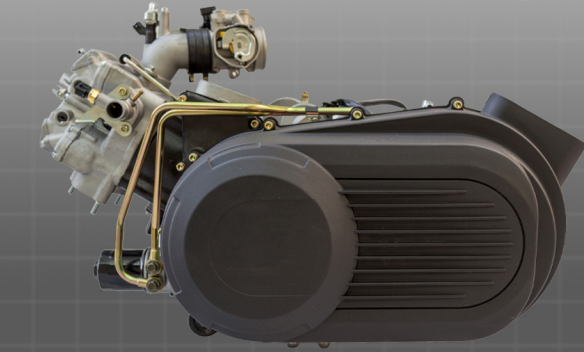

- ENGINE TYPE: FOUR STROKE SINGLE CYLINDER
- DISPLACEMENT: 694.6CC
- HORSEPOWER: 42 HP
- COOLING: LIQUID COOLED
- TRANSMISSION/FINAL DRIVE: AUTOMATIC L-H-N-R, SHAFT DRIVE
- DRIVE SYSTEM: 2WD/4WD; LOCK DIFFERENTIAL
- FUEL SYSTEM: ELECTRONIC FUEL INJECTION (EFI)

CHASSIS

- FRONT SUSPENSION: MACPHERSON INDEPENDENT
- REAR SUSPENSION: INDEPENDENT DUAL A-ARM
- FRONT TIRES: AT 25X 8-12
- REAR TIRES: AT 25X 10-12
- FRONT BRAKES: HYDRAULIC DISK BRAKES
- REAR BRAKES: HYDRAULIC DISK BRAKES

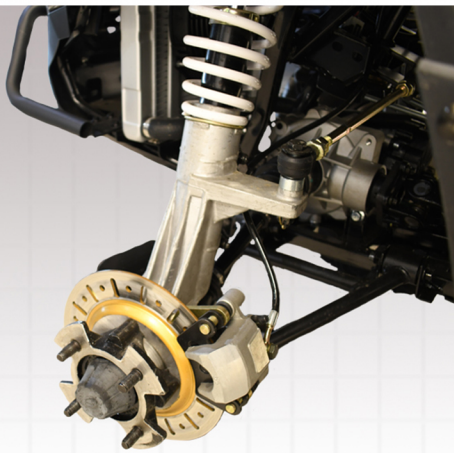

ADDITIONAL FEATURES



- ASSEMBLED IN TEXAS, USA
- INSTRUMENTATION: DIGITAL DISPLAY, SPEEDOMETER, ODOMETER, TACHOMETER, HOUR METER, GEAR INDICATOR, 4WD INDICATOR, DIFFERENTIAL LOCK INDICATOR, DUAL TRIP METER, HEADLIGHTS (HIGH/LOW), TURN SIGNALS, FUEL GAUGE, HI-TEMP, USB





MASSIMO

POWERFUL. AFFORDABLE. RELIABLE.



WWW.MASSIMOMOTOR.COM



@MASSIMOMOTOR



@MASSIMOMOTOR



MASSIMO MOTOR



MASSIMOMOTORSPORTS

Massimo Motor Sports, LLC

3101 W. Miller Rd. Garland, TX 75041 | (877) 881-6376 | customerservice@massimomotor.com

© 2020 Massimo Motor Sports, LLC